

Document Title: Engine, description	Function Group: 200	Information Type: Service Information	Date: 2014/9/11
Profile: EXC, FC2421C [GB]			

Engine, description

D6E - tier 3 compliant

The D6E configuration is a four stroke, straight six cylinder, turbocharged, direct injected diesel engine with charge air cooling and wet, replaceable cylinder liners.

The D6E engine uses a Common Rail Fuel System controlled by the engine electronic control (E-ECU) software.

Electronically controlled IEGR (Internal Exhaust Gas Recirculation) reduces NO_x formation and lowers emissions without the need for exhaust after treatment. Volvo's latest engine management system, E-ECU is used to control all engine electronic functions.

The cylinders are numbered consecutively beginning at the flywheel end. Engine rotational direction is counterclockwise as seen from the flywheel end.

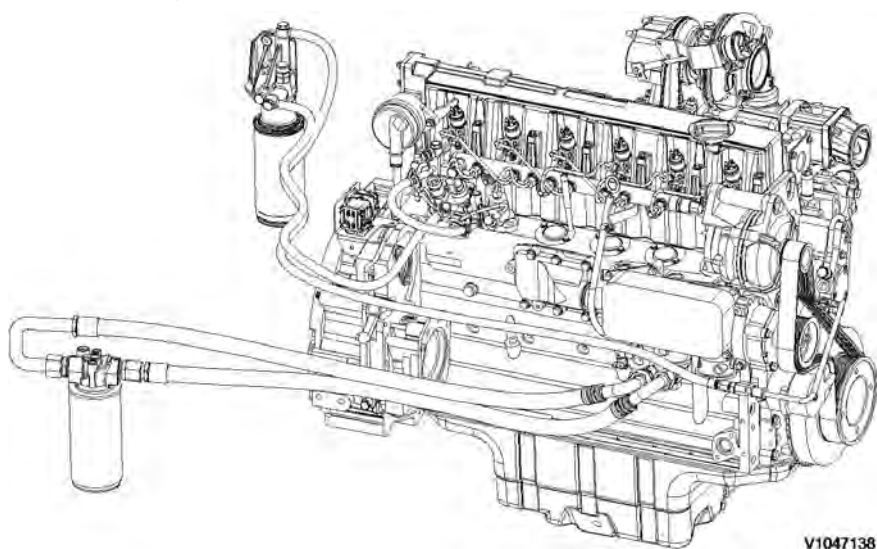

V1047138

Figure 1
Engine, D6E

Document Title: Engine, identification	Function Group: 200	Information Type: Service Information	Date: 2014/9/11
Profile: EXC, FC2421C [GB]			

Engine, identification

Identification plate

The engine model, serial number and performance data are stamped on an identification plate which is attached on the cylinder head cover. The engine model designation and serial number must be indicated when ordering spare parts.

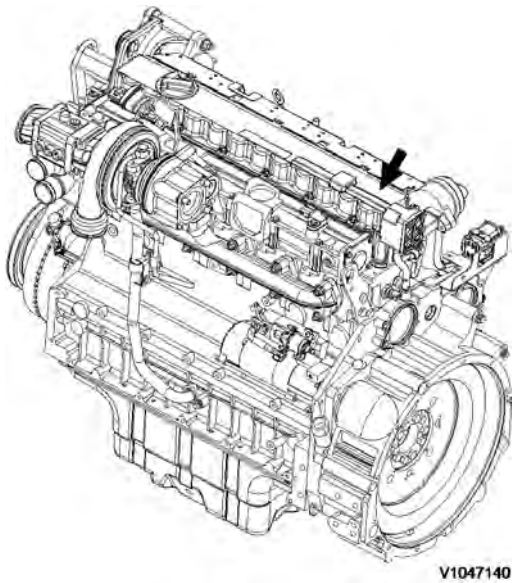

Figure 1
Engine identification, D6E

Document Title: Engine, tightening torques	Function Group: 200	Information Type: Service Information	Date: 2014/9/11
Profile: EXC, FC2421C [GB]			

Engine, tightening torques

NOTICE

Regarding bolted joints which are not listed here, see "Volvo standard tightening torques"

Engine, tightening torque	
Rocker arm bracket on cylinder head	30 Nm (22.2 lbf ft)
Cylinder head cover (M6) on cylinder head	13 Nm (9.6 lbf ft)
Exhaust return module on cylinder head	Step 1: 10 Nm (7.4 lbf ft) Step 2: 30 Nm (22.2 lbf ft)
Lock nut, valve adjusting screw	20 ±2 Nm (14.8 ±1.5 lbf ft)
Locking screw on cylinder head	34 Nm (25.2 lbf ft)
Solenoid valve on cylinder head	24 Nm (17.8 lbf ft)
Front cover on crankcase	Step 1: 3 Nm (2.2 lbf ft) Step 2: 21 Nm (15.5 lbf ft)
Drain plug on oil pan, M18	55 Nm (40.7 lbf ft)
Crankcase ventilation on cylinder head	21 Nm (15.5 lbf ft)
Return line to return stop valve	30 Nm (22.2 lbf ft)
Return stop valve to crankcase	80 Nm (59.2 lbf ft)
Impulse transmitter (crankshaft) on holder on front cover	9 Nm (6.7 lbf ft)
Impulse transmitter (camshaft) on gearcase	9 Nm (6.7 lbf ft)
Turbocharger on exhaust manifold	42 Nm (31.1 lbf ft)
Clamping shoe injector on cylinder head	16 Nm (11.8 lbf ft)
Injection lines on rail and injector, high pressure line on high-pressure pump	25 Nm (18.5 lbf ft)
Fuel supply pump on holder	22 Nm (16.3 lbf ft)
Holder fuel supply pump on holder	30 Nm (22.2 lbf ft)
V-belt pulley on fuel supply pump	27 Nm (20.0 lbf ft)
High pressure pump on crankcase, M10	Step 1: 10 Nm (7.4 lbf ft) Step 2: 50 Nm (37.0 lbf ft)
Fuel control valve	30 Nm (22.2 lbf ft)
Fuel pipe on high pressure pump	29 Nm (21.5 lbf ft)
Fuel pipe on control block	39 Nm (28.9 lbf ft)
Rail on cylinder head	30 Nm (22.2 lbf ft)
Pressure relief valve on rail	100 Nm (74.0 lbf ft)
Rail pressure sensor on rail	70 Nm (51.8 lbf ft)
Pipe clips, fuel line fastening	30 Nm (22.2 lbf ft)
Fuel line on control block, fuel filter console and rail	39 Nm (28.9 lbf ft)
Fuel pipe (return) on control block	49 Nm (36.3 lbf ft)
Fuel pipe (return) on cylinder head	29 Nm (21.5 lbf ft)
Fuel line on fuel filter8	39 Nm (28.9 lbf ft)
Fuel filter console/radiator tank on crankcase	30 Nm (22.2 lbf ft)

Fuel pressure sensor on fuel filter console	30 Nm (22.2 lbf ft)
Cover plate on cylinder cover, M6	30 Nm (22.2 lbf ft)

Document Title: Component locations	Function Group: 200	Information Type: Service Information	Date: 2014/9/11
Profile: EXC, FC2421C [GB]			

Component locations

Component position, engine D6E. The following figures show the position of a number of components on engine D6E.

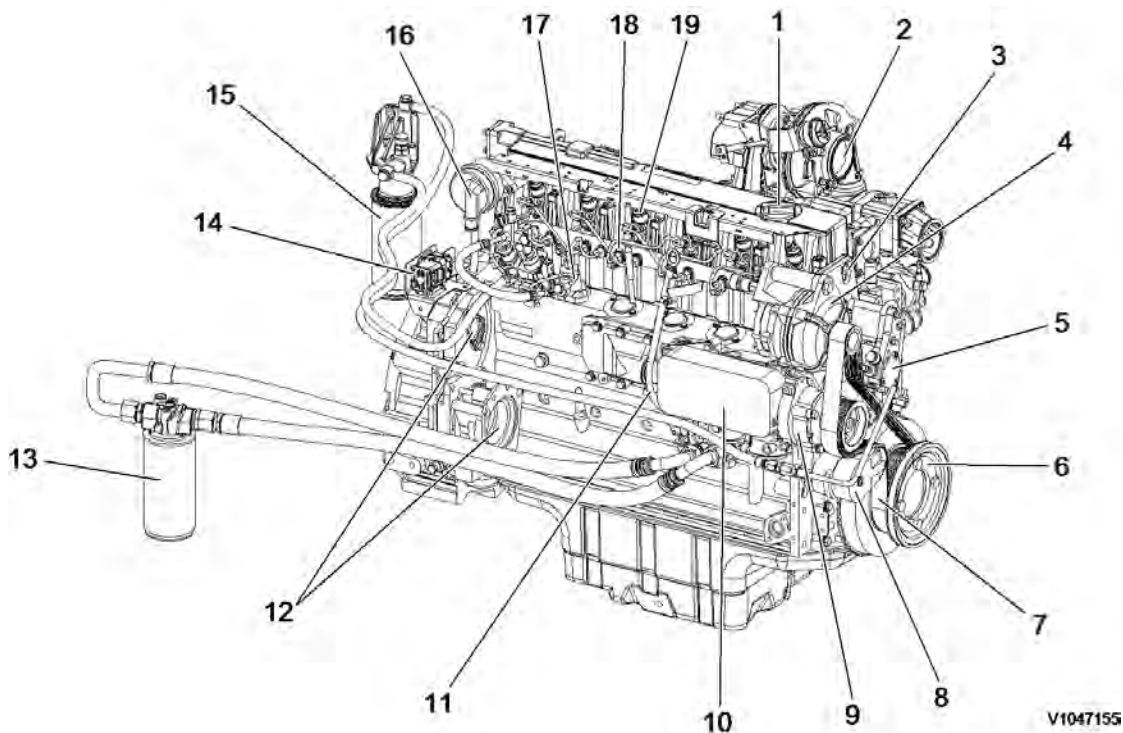
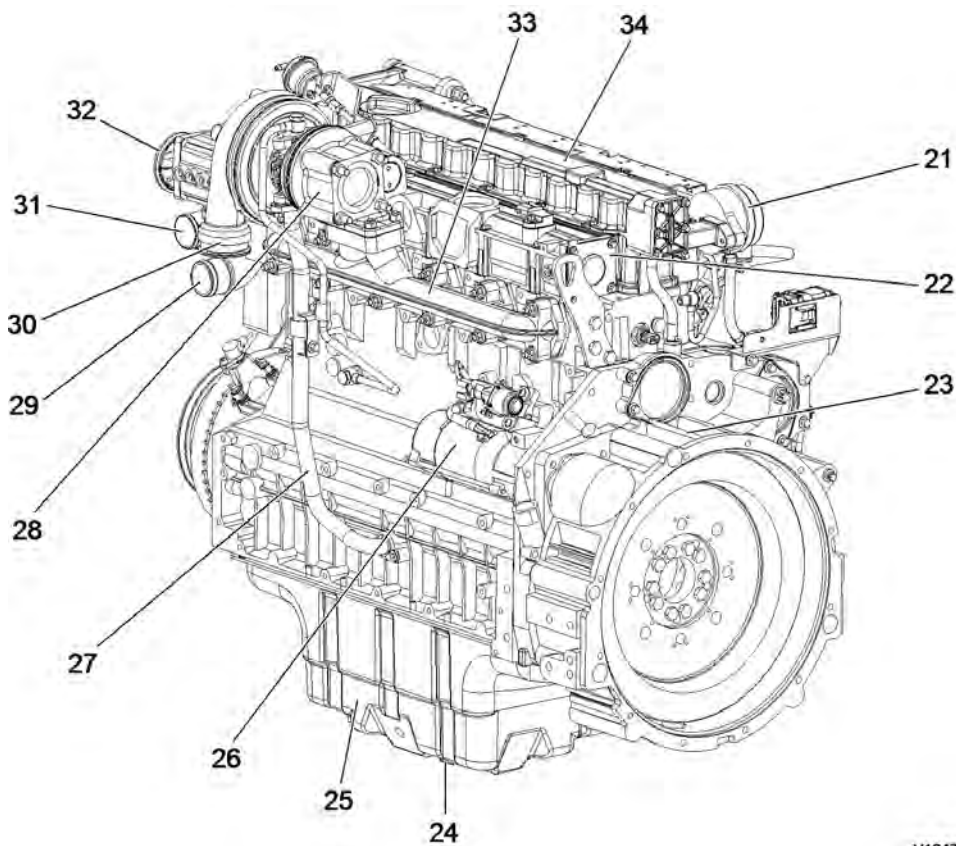

Figure 1
Component locations, front side

1	Engine oil filler	11	Oil dipstick
2	Air inlet	12	Power take off
3	Transport eye	13	Engine oil filter
4	Alternator	14	Connection to E-ECU
5	Fuel feed pump	15	Fuel filter
6	V-rib belt drive on crankshaft	16	Crankcase bleeding valve
7	V-rib belt	17	High pressure fuel pump
8	Automatic belt tensioner	18	Common rail
9	Coolant pump	19	Injector
10	Engine oil cooler		



V1047156

Figure 2
Component locations, flywheel side

21	Crankcase bleeding valve	28	Turbocharger
22	Charge air manifold	29	Coolant inlet
23	Flywheel housing	30	Air outlet (to charge air cooler)
24	Drain plug	31	Coolant outlet
25	Oil pan	32	Air inlet (from charge air cooler)
26	Starter motor	33	Exhaust manifold
27	Oil return line from turbocharger	34	Cylinder rocker arm cover

Document Title: Cylinder head, description	Function Group: 211	Information Type: Service Information	Date: 2014/9/11
Profile: EXC, FC2421C [GB]			

Cylinder head, description

The cylinder head is made of grey cast iron and is common for all cylinders. The induction air enters vertically (A) and the exhausts leave horizontally (B). Inlets and exhaust outlets are located on the same side of the cylinder block. Inlet and exhaust valve size is increased to optimize the gas exchange and combustion process. Valve guides are replaceable. Coolant flow in the cylinder head is modified to accommodate an outlet controlled cooling system.

On order for the engine to fulfill governing emission standards, there are 3 cylinder head gaskets of different thicknesses between the cylinder head and the piston.

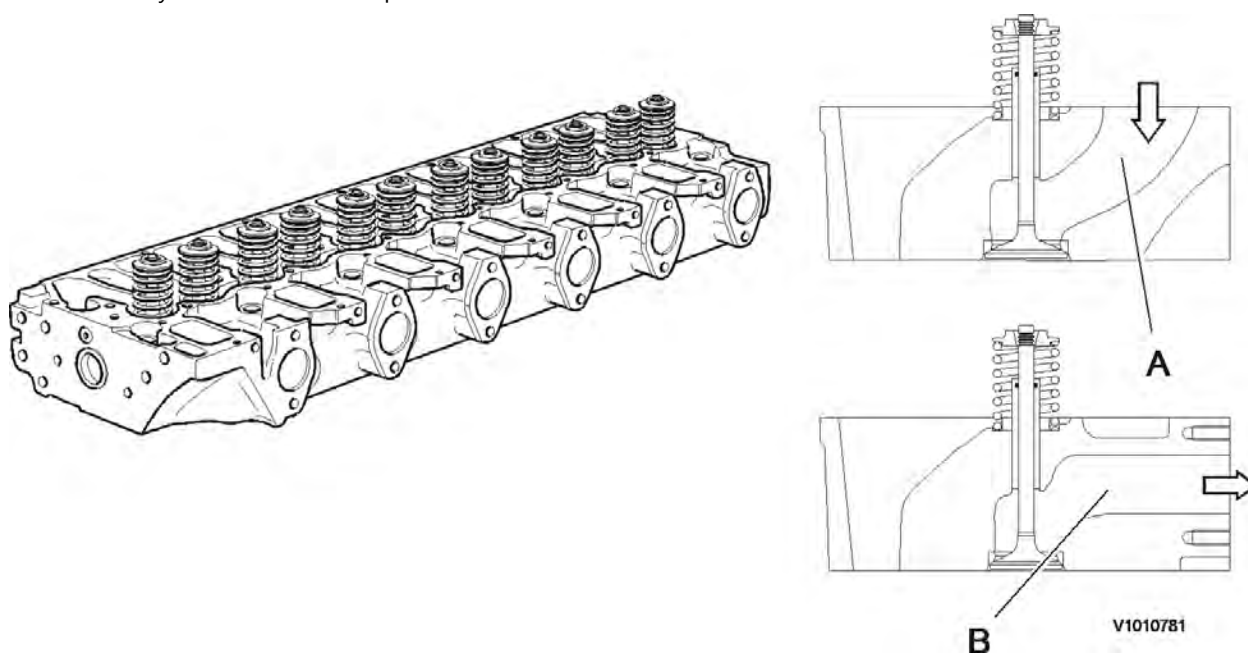

Figure 1

Document Title: Cylinder head gasket, description	Function Group: 211	Information Type: Service Information	Date: 2014/9/11
Profile: EXC, FC2421C [GB]			

Cylinder head gasket, description

The cylinder head gasket is a multi layered gasket with 1, 2 or 3 identification holes to indicate three different thicknesses available. Selection of the proper thickness of gasket is determined by the measurement of piston projection above the cylinder block sealing surface. Recalibration for the correct gasket thickness would be required if new pistons or a new cylinder block were installed.

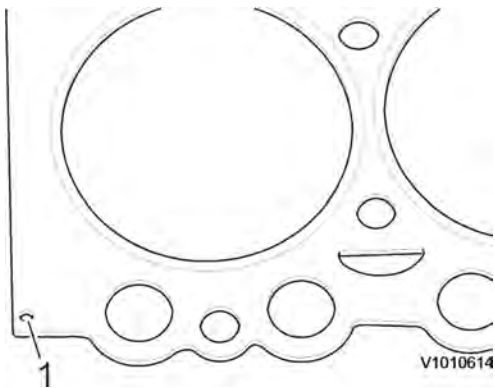

Figure 1

1. Cylinder head gasket, marking

Document Title: Cylinder block, description	Function Group: 212	Information Type: Service Information	Date: 2014/9/11
Profile: EXC, FC2421C [GB]			

Cylinder block, description

The cylinder block is cast in one piece and has wet, replaceable cylinder linings. Combustion pressure tensile breaking strength in cylinder head screws is led through stiffened sections of the cylinder block wall directly to the main bearings.

The cylinder block surface should not be ground as the distance between the pistons and the valve heads may become too small. There is also a risk that injector tips will be incorrectly placed in relation to the pistons and that exhaust valves will worsen.

Document Title: Cylinder, description	Function Group: 213	Information Type: Service Information	Date: 2014/9/11
Profile: EXC, FC2421C [GB]			

Cylinder, description

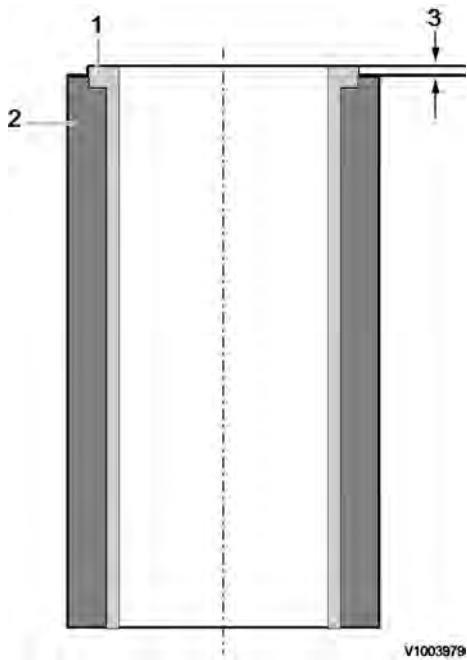

Figure 1
Cylinder liner

1	Cylinder liner
2	Crankcase
3	Liner projection: 0.07 - 0.12 mm

D6E engine with a bore about 98 mm (3.86 in) is provided with dry, plateau-honed slip-fit cylinder liners. In case of damage, the cylinders of the D6E series are repaired by replacing the slip-fit liners.

Document Title: Pistons, description	Function Group: 213	Information Type: Service Information	Date: 2014/9/11
Profile: EXC, FC2421C [GB]			

Pistons, description

D6E Engine

The pistons are made of special alloy aluminium. The piston's combustion compartment has a somewhat off-center (eccentric) position in relation to the piston pin.

The pistons are provided with 3 piston rings. The first ring has a ring carrier made of cast iron.

The piston is cooled with oil sprayed up on the inside of the piston top.

The piston cooling nozzles are made of plastic and are mounted in the cylinder head by the main bearing positions.

The first piston ring has an asymmetric cross-section area (A). The cross-section area for piston ring number two (compression ring) is tapered. When installing the piston rings, the marking TOP by the opening in the rings must face up.

The third ring is an oil ring with bevelled edge.

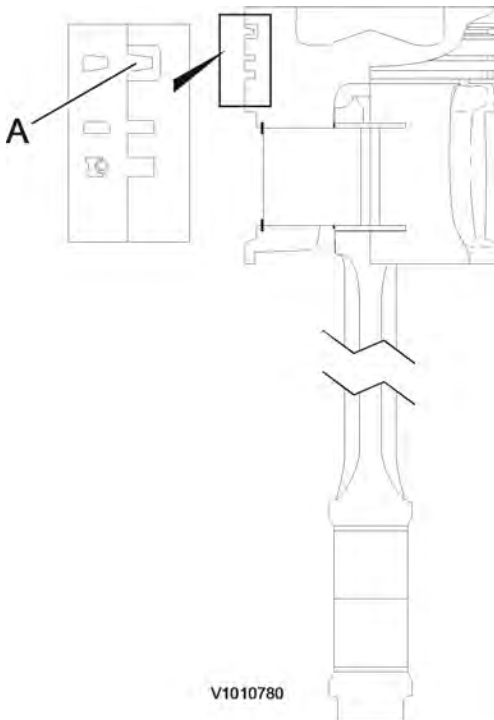

Figure 1

Document Title: Piston rings, description	Function Group: 213	Information Type: Service Information	Date: 2014/9/11
Profile: EXC, FC2421C [GB]			

Piston rings, description

Each piston is equipped with two compression rings and one oil ring. The uppermost compression ring is of the "Keystone" type (dual trapezoid-formed cross section). Compressions rings should be placed with the text facing upwards.

The oil ring is equipped with two scraping edges, which are pressed against the cylinder wall using the spring tension in the ring and an expander spring placed on the inside of the ring. The oil ring can be placed on either side but should be placed with expander spring and oil ring openings 180° from one another.

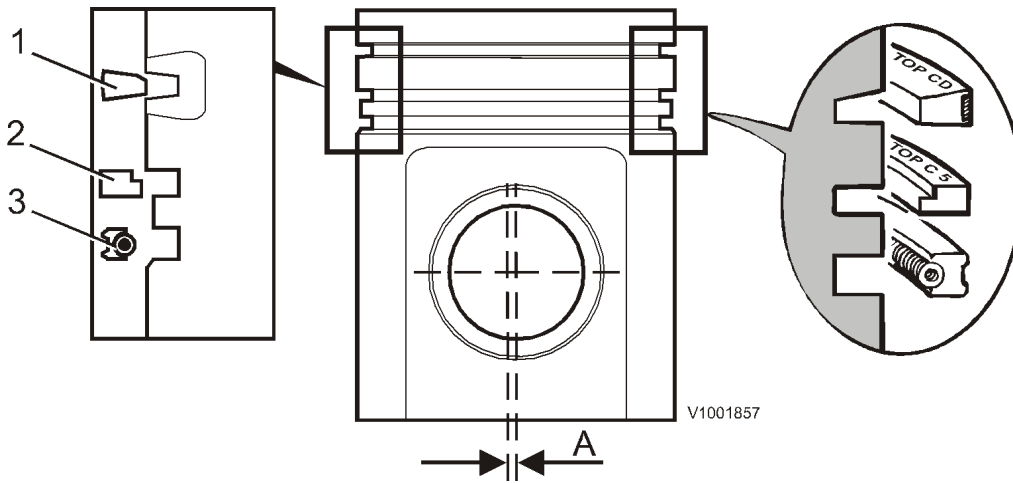

Figure 1

Document Title: Valves, description	Function Group: 214	Information Type: Service Information	Date: 2014/9/11
Profile: EXC, FC2421C [GB]			

Valves, description

The engines are equipped with one inlet and one exhaust valve per cylinder.

At the upper end of the valve guide, there is an O-ring seal (A) against the valve spindle to prevent major oil consumption and to reduce the amount of hydrocarbons in the exhausts.

The valves are rotated by the eccentric action of the rocker arms.

The new compressed tapered shape enables the valves to turn easily despite loading.

Rocker arm lubrication is part of the engine force-feed lubrication system. The oil is supplied via the tappets and push rods.

If the valve guides are replaced, they are obtained in another version (B) to facilitate installation.

Figure 1 shows a valve guide installed in production and figure 2 shows a replacement guide.

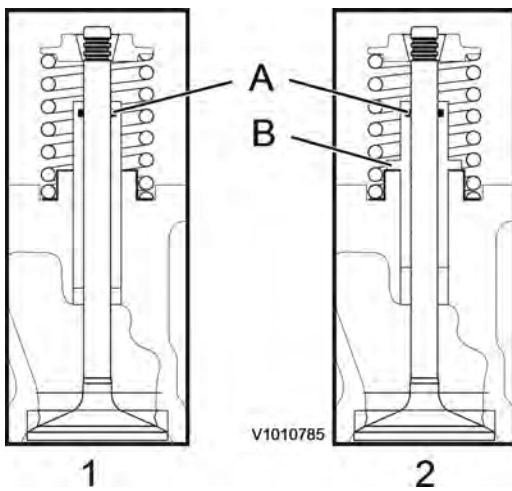

Figure 1

Document Title: Valves, adjusting	Function Group: 214	Information Type: Service Information	Date: 2014/9/11
Profile: EXC, FC2421C [GB]			

Valves, adjusting

Op nbr 214-012

[9998681 Rotation tool](#)

[885812 Timing tool](#)

WARNING

Risk of burns - stop the diesel engine and allow it to cool down before starting any work.

1. Place the machine in service position B. See [091 Service positions](#)
2. Open the engine hood and right side cover.
3. Remove turbocharger inlet hose clamping screws (1), coolant air ventilation hose clamping screw (2) and bracket mounting screws (3).

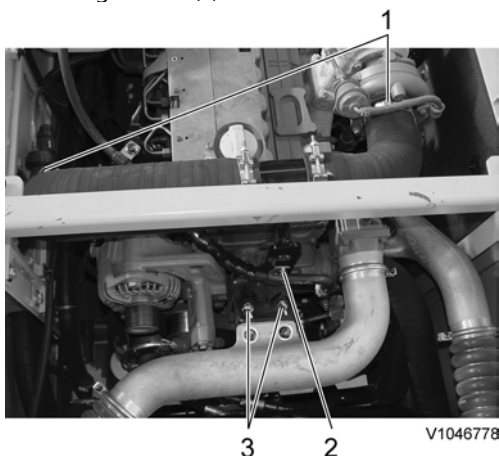

Figure 1

4. Remove cover plate (1).



Buy Now



Our support email:

ebooklibonline@outlook.com