

Document Title: Component locations	Function Group: 200	Information Type: Service Information	Date: 2014/6/3 0
Profile: WLO, L180G HL [GB]			

[Go back to Index Page](#)

Component locations

Engine, component positions

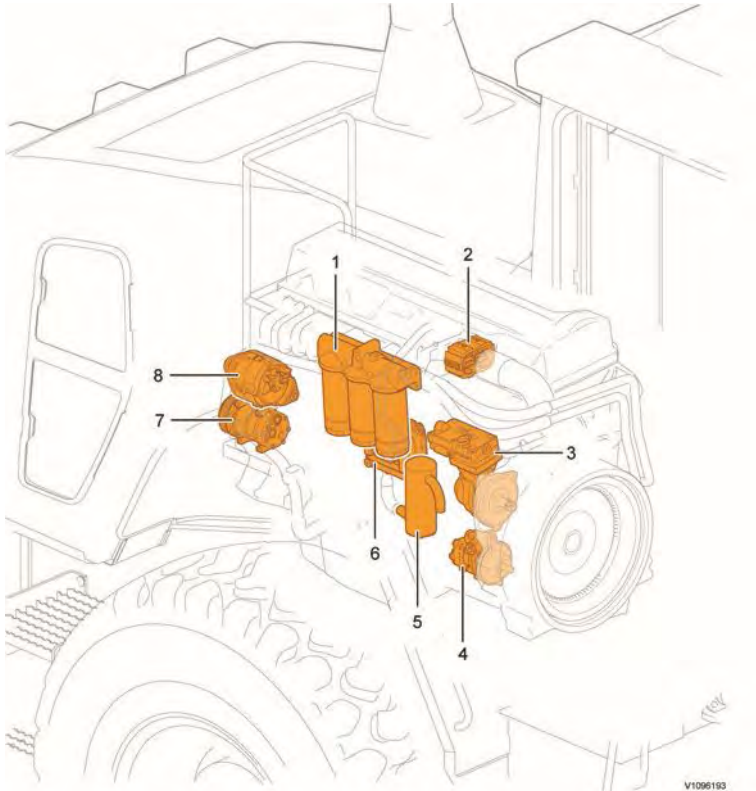

Figure 1

1. Remote oil filter housing
2. Preheater, inlet manifold
3. Compressor
4. Fuel pump
5. External oil trap
6. E-ECU
7. AC compressor
8. Alternator

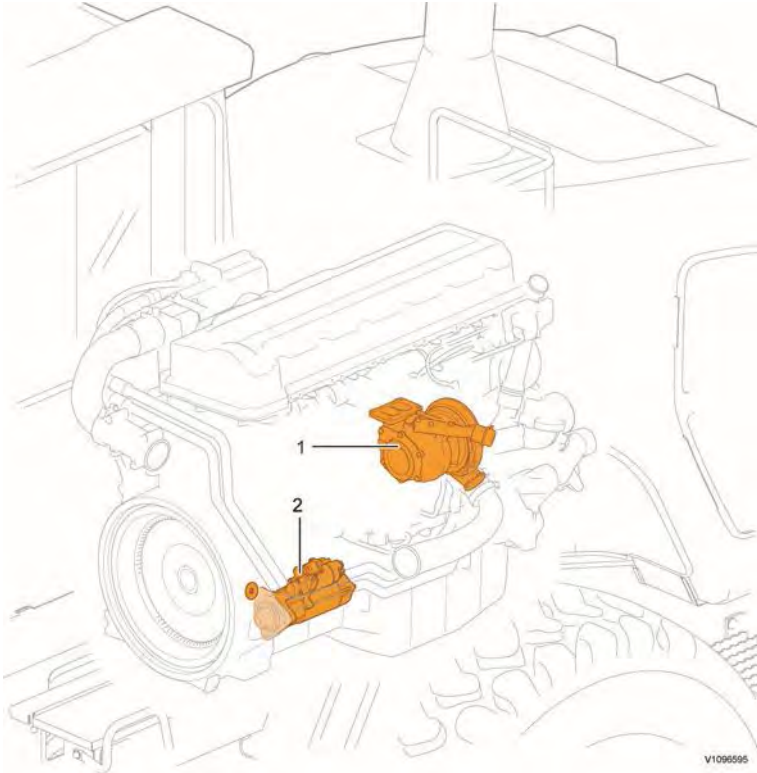

Figure 2

1. Turbocharger with wastegate valve
2. Starter motor

Document Title: Component locations	Function Group: 200	Information Type: Service Information	Date: 2014/6/3 0
Profile: WLO, L180G HL [GB]			

[Go back to Index Page](#)

Component locations

Engine, component positions

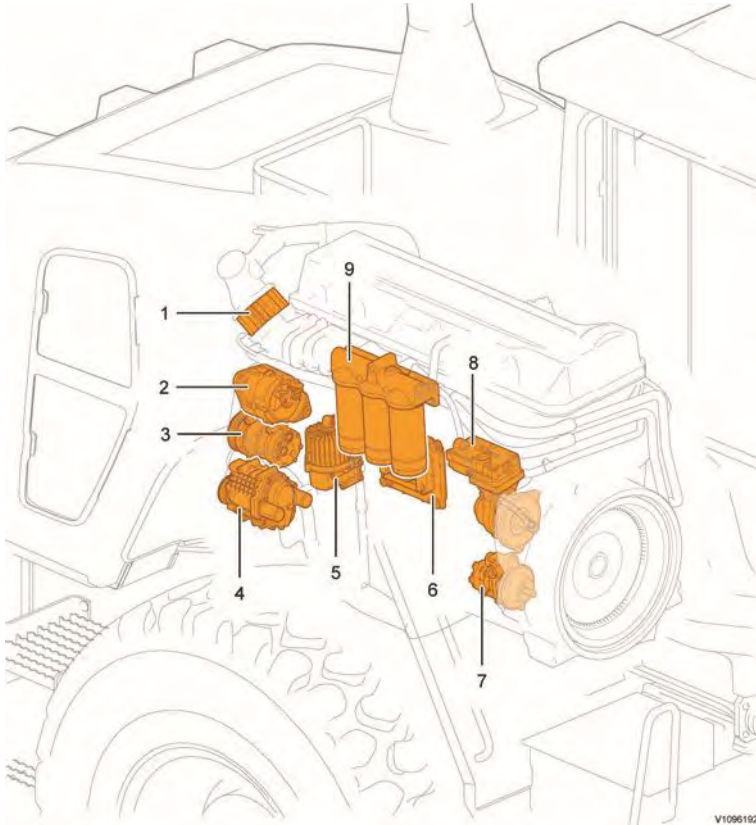

Figure 1

1. Preheater, inlet manifold
2. Alternator
3. AC compressor
4. Air pump for Exhaust Aftertreatment System
5. Crankcase ventilation, separator
6. E-ECU
7. Fuel pump
8. Compressor
9. Remote oil filter housing

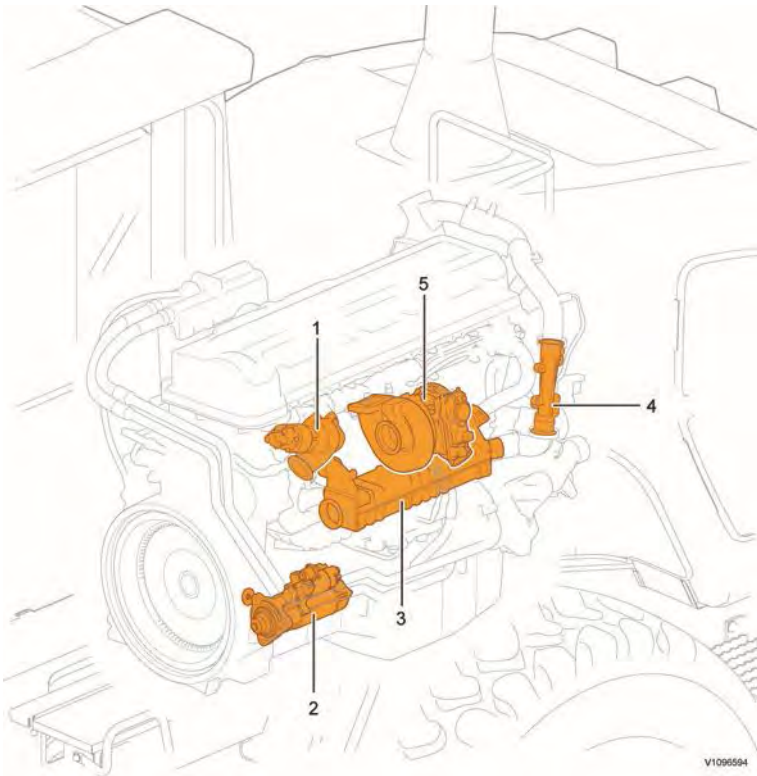

Figure 2

1. Exhaust Gas Recirculation (EGR), description
2. Starter motor
3. EGR-cooler
4. EGR venturi tube
5. Variable geometry turbine (VGT) turbocharger

Document Title: Engine, description	Function Group: 200	Information Type: Service Information	Date: 2014/6/3 0
Profile: WLO, L180G HL [GB]			

[Go back to Index Page](#)

Engine, description

Engines D11F, D13F, and D16F are straight six-cylinder, four-stroke, direct-injected diesel engines. Engines D13F and D16F are equipped with a single turbocharger with wastegate and engine D11F has a turbocharger without wastegate. They have charge-air cooling with mechanically actuated electronically controlled unit injectors, controlled by the EMS-system. The engines have a one-piece cylinder head with four valves per cylinder and a single overhead camshaft. Rear-mounted timing gear results in a shorter engine and lighter drivetrain installation. Engine brake for Articulated Hauler; VEB+ (EPG, Exhaust Pressure Governor, and VCB, Volvo Compression Brake).

For more information, see:

- [220 Lubrication system, description](#)
- [230 Fuel system, description](#)
- [250 Inlet and exhaust system, description](#)
- [255 Turbocharger, description](#)
- [260 Cooling system, description](#)

For Articulated Haulers:

- [253 Auxiliary brake \(engine braking\), description](#)
- [253 Exhaust pressure governor](#)

The cylinders are numbered in sequence, starting farthest from the flywheel. Ignition order: 1-5-3-6-2-4. The engine's rotational direction is counter-clockwise, seen from the flywheel.

Engine identification

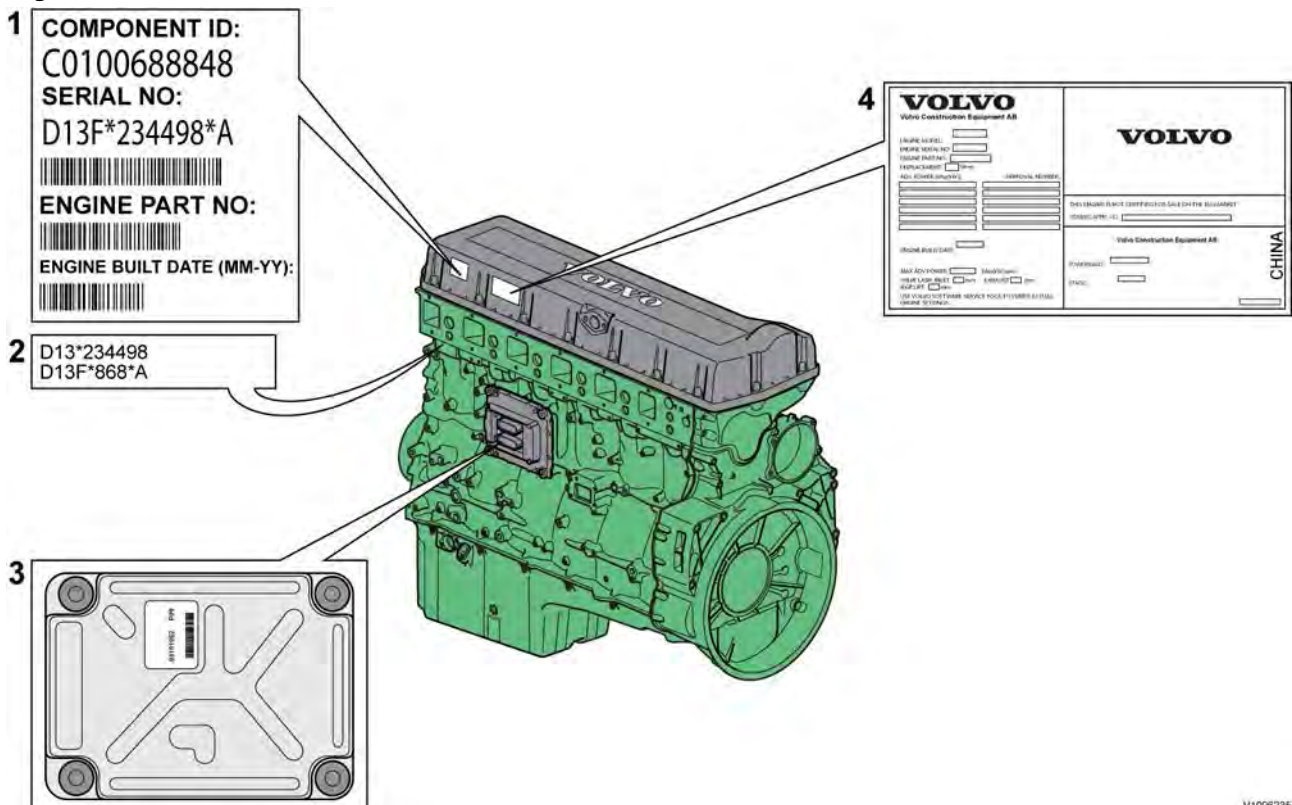

Figure 1

Identification plates, D13F

Identification plate 1

A label located on the valve cover showing the engine's component ID-number, serial number, manufacturing site, engine part number, and engine build date, as well as their bar codes. Manufacturing sites:

- A = Skövde, Sweden
- E = Curitiba, Brazil
- F = Flen, Sweden
- L = Lyon, France

Identification plate 2

The engine's serial number, part number, and manufacturing site are stamped into the engine's cylinder block.

Identification plate 3

The hardware component number of the Engine Control Unit (ECU) is located on a label on the back of the ECU.

Identification plate 4

The certification label is located on the valve cover as well as the machine's frame.

Automatic Engine Shutdown

This is a function used to automatically shut down the engine after idling for a certain time. The operator is informed and has the opportunity to cancel the function within one minute, either by increasing the engine speed, shifting gear, or by activating the hand throttle.

Engine protection

The ECU contains functionality designed to protect the engine from damage during extreme operating conditions or from further damage when an essential engine component fails. There are several proactive functions, and different applications have different functions activated. The ones that can be activated are:

- High coolant temperature
- High intake manifold air pressure
- High intake manifold air temperature
- High oil temperature
- Low oil pressure
- Low coolant level
- High crankcase pressure
- High ECU temperature

Various protective actions such as warning lights, engine torque reduction, engine speed limitation, and vehicle speed limitation may be taken when the above functions reach dangerous levels that may damage the engine. In order to always allow the operator to move a machine away from an unsafe situation, there is a delay of at least 30 seconds before the protective actions (such as forced idle and forced shutdown) are activated after a Key-ON. If the engine has been forced to shutdown or forced to idle due to an active engine protection function, the operator can obtain a 30 second delay by powering down the EMS with a Key-OFF for 7 seconds and then a Key-ON (the EMS is powered down by the Vehicle-ECU (V-ECU) after the ignition key has been in its OFF position for approx. 7 seconds). In addition to the above protective functions, other software functions could request engine protection, such as:

- High Altitude (ensures that high compressor discharge temperature is never reached)
- Turbo OverSpeed
- Low Coolant Temp
- Crank Sensor Failure
- Gear Ratio

Warning lights

There are two levels for warning lights, an amber caution light and a red stop light.

- The **amber light** indicates a warning situation
- The **red light** indicates that the vehicle must be stopped.

Engine torque limitation

The engine torque can be limited by the engine protection function. Engine torque limitation is active until the parameter

has reached a safe level or until the EMS is powered down.

Forced Idle

The engine can be forced to idle speed by the engine protection function. Forced idle is active until conditions triggering the problem are back within normal working range or the EMS is powered down.

Engine Shutdown

The engine can be forced to shut down after conditions have reached levels that may cause engine failure and the machine speed is below a specified value.

Machine Speed and Engine Speed Limits

The engine protection function can limit the speed of the vehicle and/or the engine's rpm.

Levels of engine protection

Available proactive functions depend not only on the application but also on what level of protection has been activated for the specific machine. Two levels of engine protection are offered, the standard level is Basic protection and the optional level Extended protection. The general difference between basic and extended engine protection is that no active actions such as forced idle and forced shutdown will be taken in basic engine protection (with the exception of crankcase pressure that can cause shutdown in either setup). Warnings will be given to the operator regardless of engine protection level.

Parameters

- (ATJ) Injector cylinder 1, calibration
- (ATK) Injector cylinder 2, calibration
- (ATL) Injector cylinder 3, calibration
- (ATM) Injector cylinder 4, calibration
- (ATN) Injector cylinder 5, calibration
- (ATO) Injector cylinder 6, calibration
- (FAU) Automatic engine shut off
- (FAV) Automatic engine shut off, time
- (YA) Idle speed, setting

Supplementary information

- [200 Component locations](#)

Function check

- 17030-3 Parameter, programming

Diagnostics

Detailed information about the following relevant warnings and error codes is available under the diagnostics tab.

Component	Control unit	Message ID
EF2117 (ART) PPID55 (WLO, EXC)	MID128	PPID55
SE2202 FX1006 (WLO)	MID128	PID175
SE2507 FX1007 (WLO)	MID128	PID105
SE2203	MID128	PID100
SE2509	MID128	PID153
SE2603	MID128	PID111
SE2606	MID128	PID110

Document Title: Engine, description	Function Group: 200	Information Type: Service Information	Date: 2014/6/3 0
Profile: WLO, L180G HL [GB]			

[Go back to Index Page](#)

Engine, description

Engines D11H, D13H, and D16H are straight six-cylinder, four-stroke, direct-injected diesel engines. They are equipped with a single variable geometry turbocharger (VGT) and feature cooled external exhaust gas recirculation (EGR). They have charge-air cooling with mechanically actuated electronically controlled unit injectors, controlled by the EMS-system.

The engines have a one-piece cylinder head with four valves per cylinder and a single overhead camshaft. Rear-mounted timing gear results in a shorter engine and lighter drivetrain installation. The engine brake for articulated haulers, VEB7, does not have the additional Exhaust Pressure Governor, EPG. Sufficient exhaust back-pressure will be controlled via the VGT.

For more information, see:

- [220 Lubrication system, description](#)
- [230 Fuel system, description](#)
- [250 Inlet and exhaust system, description](#)
- [254 Exhaust Aftertreatment System, description](#)
- [255 Turbocharger, description](#)
- [260 Cooling system, description](#)
- [293 Exhaust Gas Recirculation \(EGR\), description](#)

For Articulated Haulers:

- [253 Auxiliary brake \(engine braking\), description](#)

The cylinders are numbered in sequence, starting farthest from the flywheel. Ignition order: 1-5-3-6-2-4. The engine's rotational direction is counter-clockwise, seen from the flywheel.

Engine identification

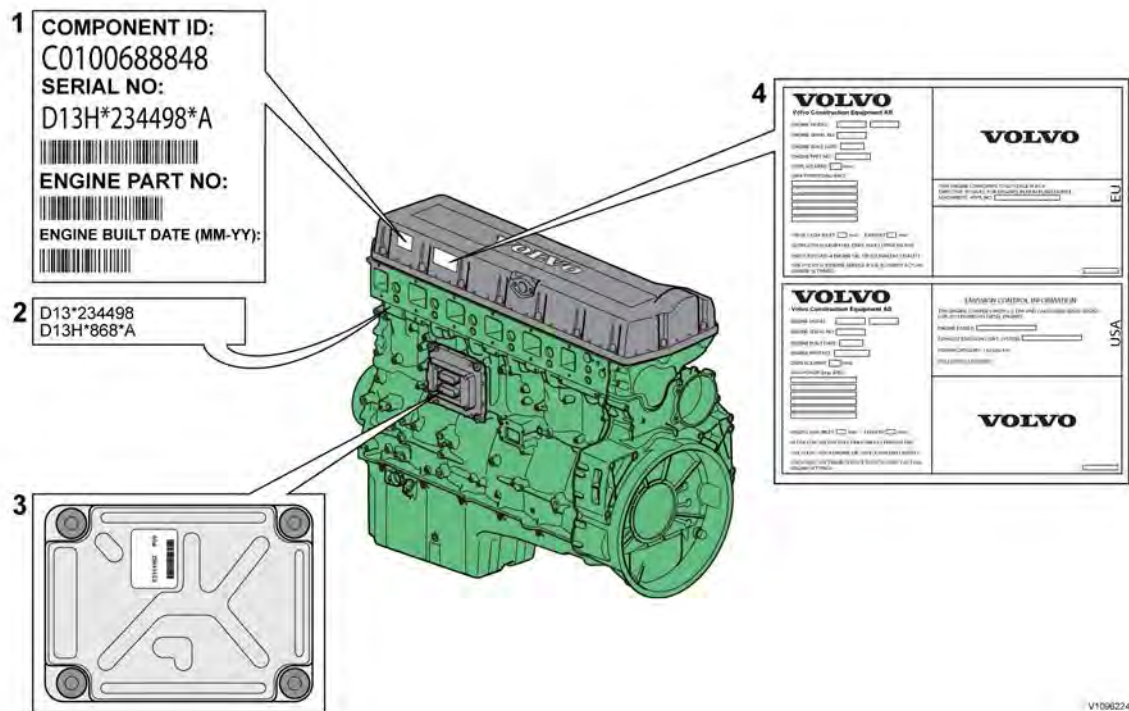

Figure 1
Identification plates, D13H

Identification plate 1

A label located on the valve cover showing the engine's component ID-number, serial number, manufacturing site, engine part number, and engine build date, as well as their bar codes. Manufacturing sites:

- A = Skövde, Sweden
- E = Curitiba, Brazil
- F = Flen, Sweden
- L = Lyon, France

Identification plate 2

The engine's serial number, part number, and manufacturing site are stamped into the engine's cylinder block.

Identification plate 3

The hardware component number of the Engine Control Unit (ECU) is located on a label on the back of the ECU.

Identification plate 4

The certification label is located on the valve cover as well as the machine's frame.

Automatic Engine Shutdown

This is a function used to automatically shut down the engine after idling for a certain time. The operator is informed and has the opportunity to cancel the function within one minute, either by increasing the engine speed, shifting gear, or by activating the hand throttle.

Engine protection

The ECU contains functionality designed to protect the engine from damage during extreme operating conditions or from further damage when an essential engine component fails. There are several proactive functions, and different applications have different functions activated. The ones that can be activated are:

- High coolant temperature

- High intake manifold air pressure
- High intake manifold air temperature
- High oil temperature
- Low oil pressure
- Low coolant level
- High temperature of cooled EGR exhausts after the EGR-cooler
- High crankcase pressure
- Variable Geometry Turbo valve and position error
- High temperature of Smart Remote Actuator
- High compressor charge-air temperature (calculated)
- High soot load
- High differential pressure across Diesel Particulate Filter (DPF)
- High exhaust temperature
- High ECU temperature
- High DPF temperature

Various protective actions such as warning lights, engine torque reduction, engine speed limitation, and vehicle speed limitation may be taken when the above functions reach dangerous levels that may damage the engine. In order to always allow the operator to move a machine away from an unsafe situation, there is a delay of at least 30 seconds before the protective actions (such as forced idle and forced shutdown) are activated after a Key-ON. If the engine has been forced to shutdown or forced to idle due to an active engine protection function, the operator can obtain a 30 second delay by powering down the EMS with a Key-OFF for 7 seconds and then a Key-ON (the EMS is powered down by the Vehicle-ECU (V-ECU) after the ignition key has been in its OFF position for approx. 7 seconds). In addition to the above protective functions, other software functions could request engine protection, such as:

- High Altitude (ensures that high compressor charge-air temperature is never reached)
- Turbo OverSpeed
- Low Coolant Temp
- Crank Sensor Failure
- Gear Ratio
- Regeneration

Warning lights

There are two levels for warning lights, an amber caution light and a red stop light.

- The **amber light** indicates a warning situation
- The **red light** indicates that the vehicle must be stopped.

Engine torque limitation

The engine torque can be limited by the engine protection function. Engine torque limitation is active until the parameter has reached a safe level or until the EMS is powered down.

Forced Idle

The engine can be forced to idle speed by the engine protection function. Forced idle is active until conditions triggering the problem are back within normal working range or the EMS is powered down.

Engine Shutdown

The engine can be forced to shut down after conditions have reached levels that may cause engine failure and the machine speed is below a specified value.

Machine Speed and Engine Speed Limits

The engine protection function can limit the speed of the vehicle and/or the engine's rpm.

Levels of engine protection

Available proactive functions depend not only on the application but also on what level of protection has been activated for the specific machine. Two levels of engine protection are offered, the standard level is Basic protection and the optional level Extended protection. The general difference between basic and extended engine protection is that no active actions such as forced idle and forced shutdown will be taken in basic engine protection (with the exception of crankcase pressure that can cause shutdown in either setup). Warnings will be given to the operator regardless of engine protection level.

Parameters

- (FAU) Automatic engine shut off
- (FAV) Automatic engine shut off, time

- (JVL) Injector cylinder 1, calibration E3 Glitch Trim
- (JVM) Injector cylinder 2, calibration E3 Glitch Trim
- (JVN) Injector cylinder 3, calibration E3 Glitch Trim
- (JVO) Injector cylinder 4, calibration E3 Glitch Trim
- (JVP) Injector cylinder 5, calibration E3 Glitch Trim
- (JVQ) Injector cylinder 6, calibration E3 Glitch Trim
- (YA) Idle speed, setting

Supplementary information

- [200 Component locations](#)

Function check

- 17030-3 Parameter, programming

Diagnostics

Detailed information about the following relevant warnings and error codes is available under the diagnostics tab.

Component	Control unit	Message ID
EF2112 (ART) PID404 (EXC, WLO)	MID128	PID404
EF2117 (ART) PPID55 (WLO, EXC)	MID128	PPID55
EF2127 (ART) PPID89 (EXC, WLO)	MID128	PPID89
EF2515 (ART) PSID28 (WLO, EXC)	MID128	PSID28
EF2525 (ART) PID173 (EXC) SE2510 (WLO)	MID128	PID173
SE2202 FX1006 (WLO)	MID128	PID175
SE2507 FX1007 (WLO)	MID128	PID105
MO2501	MID128	SID27
PPID326 (WLO, EXC)	MID128	PPID326
SE2203	MID128	PID100
SE2509	MID128	PID153
SE2516	MID128	PID412
SE2519	MID128	PID81
SE2603	MID128	PID111
SE2606	MID128	PID110

Document Title: E-ECU, MID 128, changing non-programmed ECU	Function Group: 200	Information Type: Service Information	Date: 2014/6/3 0
Profile: WLO, L180G HL [GB]			

E-ECU, MID 128, changing non-programmed ECU

Op nbr 200-068

[VCADS Pro VCADS Pro Service Tool](#)

[88890180 Interface](#)

[88890027 Cable](#)

1. Place the machine in service position 1, see [191 Service position](#).
2. Connect VCADS Pro and start operation 28423-3 MID 128 ECU, programming.
3. Turn off the voltage with the battery disconnecter.
4. Remove the engine cover on the right side.
5. Disconnect and move aside the pipe for the crankcase ventilation.

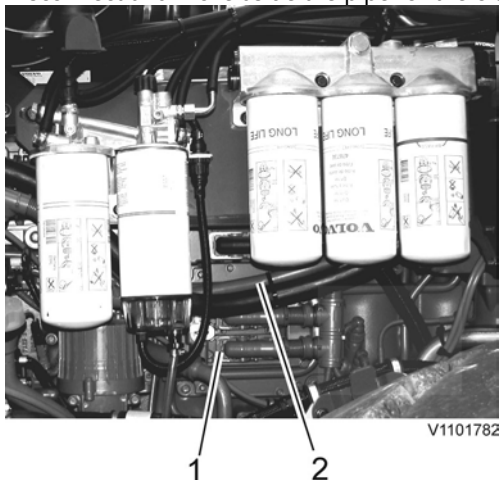

Figure 1

1. E-ECU
 2. Crankcase ventilation
6. Disconnect the cable clamps for the alternator cable.
 7. Unplug the connectors from the E-ECU and loosen the cable harness clamps.
 8. Disconnect the cooling coil from the E-ECU and move the cooling coil aside.
 9. Replace the E-ECU.
 10. Install the cooling circuit.

11. Plug in the connectors and install the cable harness clamps.
12. Install the cable clamps for the alternator cable.
13. Install the pipe for the crankcase ventilation.
14. Install the engine cover.
15. Turn on the voltage with the battery disconnecter.
16. Finish the VCADS Pro operation 28423-3 MID 128 ECU, programming.
17. Start the machine and check that there are no error messages.
18. Run a service regeneration to ensure the actual soot level in the DPF, see [254 Perform a service regeneration](#).
19. Restore the machine.

Document Title: E-ECU, MID 128, changing pre-programmed ECU	Function Group: 200	Information Type: Service Information	Date: 2014/6/3 0
Profile: WLO, L180G HL [GB]			

E-ECU, MID 128, changing pre-programmed ECU

Op nbr 200-070

[VCADS Pro VCADS Pro Service Tool](#)

[88890180 Interface](#)

[88890027 Cable](#)

1. Place the machine in service position 1, see [191 Service position](#).
2. The new control unit has basically adjusted parameters for the machine. Connect VCADS Pro and read out customer parameters from the old control unit with operation 17030-3 Parameter, programming. If it is possible to read out customer parameters from the old control unit, save them on the job card.
3. Turn off the voltage with the battery disconnecter.
4. Remove the engine cover on the right side.
5. Disconnect the pipe for crankcase ventilation.

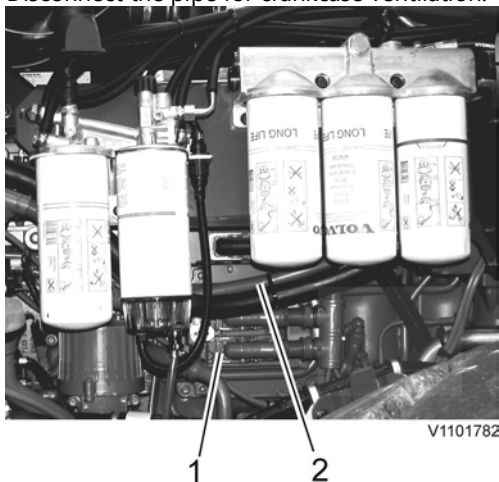

Figure 1

1. E-ECU
 2. Crankcase ventilation
6. Disconnect the cable clamps for the alternator cable.
 7. Unplug the connectors from the E-ECU and loosen the cable harness clamps.
 8. Disconnect the cooling coil from the E-ECU and move the cooling coil aside.
 9. Replace the E-ECU.

Buy Now



Our support email:

ebooklibonline@outlook.com