

**JOHN DEERE**  
**WORLDWIDE COMMERCIAL & CONSUMER**  
**EQUIPMENT DIVISION**

---

**Large Area Reel Mower**  
**1905**

**OMDMU21001 C4**  
**OPERATOR'S MANUAL**



**JOHN DEERE**

**⚠ WARNING:** Diesel engine exhaust and some of its constituents are known to the State of California to cause cancer, birth defects, and other reproductive harm.

California Proposition 65 Warning

North American Version  
Litho in the Netherlands

# INTRODUCTION

---

## Thank You for Purchasing a John Deere Product

We appreciate having you as a customer and wish you many years of safe and satisfied use of your machine.

## Using Your Operator's Manual

This manual is an important part of your machine and should remain with the machine when you sell it.

Reading your operator's manual will help you and others avoid personal injury or damage to the machine.

Information given in this manual will provide the operator with the safest and most effective use of the machine.

Knowing how to operate this machine safely and correctly will allow you to train others who may operate this machine.

If you have an attachment, use the safety and operating information in the attachment operator's manual along with the machine operator's manual to operate the attachment safely and correctly.

This manual and safety signs on your machine may also be available in other languages (see your John Deere dealer to order).

Section in your operator's manual are placed in a specific order to help you understand all the safety messages and learn the controls so you can operate this machine safely. You can also use this manual to answer any specific operating or servicing questions. A convenient index located at the end of this book will help you to find needed information quickly.

The machine shown in this manual may differ slightly from your machine, but will be similar enough to help you understand our instructions.

RIGHT-HAND and LEFT-HAND sides are determined by facing in the direction the machine will travel when going forward. When you see a broken line arrow (----->), the item referred to is hidden from view.

Before delivering this machine, your dealer performed a predelivery inspection to ensure best performance.

## Special Messages

Your manual contains special messages to bring attention to potential safety concerns, machine damage as well as helpful operating and servicing information. Please read all the highlighted information carefully to avoid injury and machine damage.



**CAUTION: Avoid injury! This symbol and text highlight potential hazards or death to the operator or bystanders may occur if the hazards or procedures are ignored.**

**IMPORTANT: Avoid damage! This text is used to tell the operator of actions or conditions that might result in damage to the machine.**

***NOTE: General information is given throughout the manual that may help the operator in the operation or service of the machine.***

# PRODUCT IDENTIFICATION

---

## Record Identification Numbers

### 1905 Large Area Reel Mower

PIN (1905 X 195001 - )

If you need to contact an Authorized Service Center for information on servicing, always provide the product model and serial number.

You will need to locate the model and serial number for the machine and for the engine of your machine and record the information in the spaces provided below.

DATE OF PURCHASE:

\_\_\_\_\_

DEALER NAME:

\_\_\_\_\_

DEALER PHONE:

\_\_\_\_\_

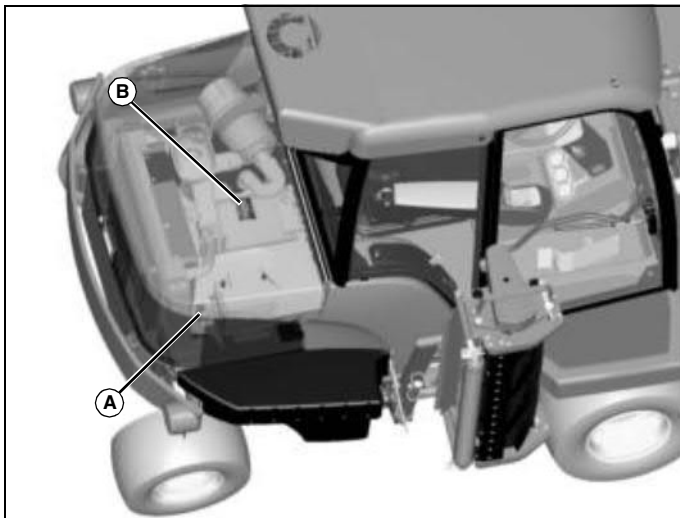

DM1239

PRODUCT IDENTIFICATION NUMBER (A):

-----

ENGINE SERIAL NUMBER (B):

-----

# TABLE OF CONTENTS

---

Safety .....	1
Operating.....	11
Operating Cutting Units .....	25
Replacement Parts .....	28
Service Intervals.....	29
Service Lubrication.....	30
Service Engine .....	32
Service Cutting Units.....	40
Service Transmission.....	46
Service Electrical.....	48
Service Miscellaneous.....	52
Troubleshooting .....	56
Storage .....	62
Assembly .....	64
Specifications .....	68
Warranty .....	69
Index.....	71

All information, illustrations and specifications in this manual are based on the latest information at the time of publication. The right is reserved to make changes at any time without notice.

COPYRIGHT© 2004  
Deere & Co.  
John Deere Worldwide Commercial and  
Consumer Equipment Division  
All rights reserved  
Previous Editions  
COPYRIGHT©

OMDMU21001 C4 - English

# SAFETY

## Understanding The Machine Safety Labels

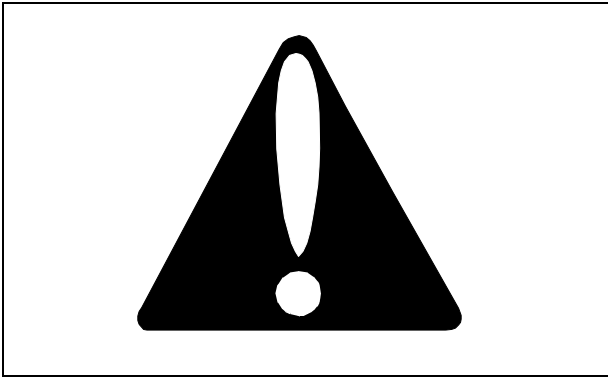

Safety-Alert Symbol

The machine safety labels shown in this section are placed in important areas on your machine to draw attention to potential safety hazards.

On your machine safety labels, the words DANGER, WARNING, and CAUTION are used with this safety-alert symbol. DANGER identifies the most serious hazards.

The operator's manual also explains any potential safety hazards whenever necessary in special safety messages that are identified with the word, CAUTION, and the safety-alert symbol.

## CAUTION

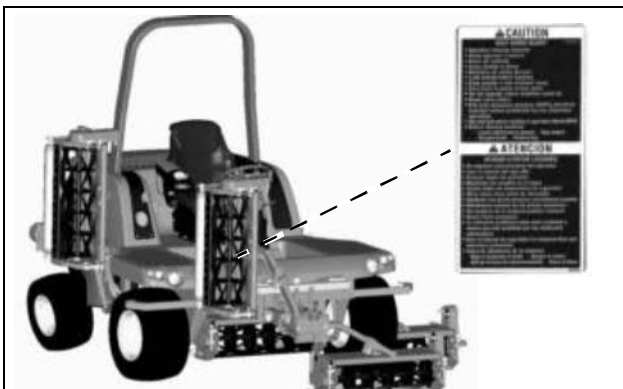

DM1296 / DM1236

- Operator training required.
- Read operator's manual.
- Know all controls.
- Maintain all safety devices.
- Look behind before backing.
- Keep people a safe distance away.
- Stay clear of power driven parts.
- Do Not operate where machine could tip.

- Never carry riders.
- Roll-Over Protection Structure (ROPS) should be installed unless prohibited by low clearance operation.
- Use seat belts unless machine is operated without ROPS.
- Before leaving machine
  - a. Lower attachment to ground
  - b. Stop engine.
  - c. Lock park brake.
  - d. Remove key

## WARNING

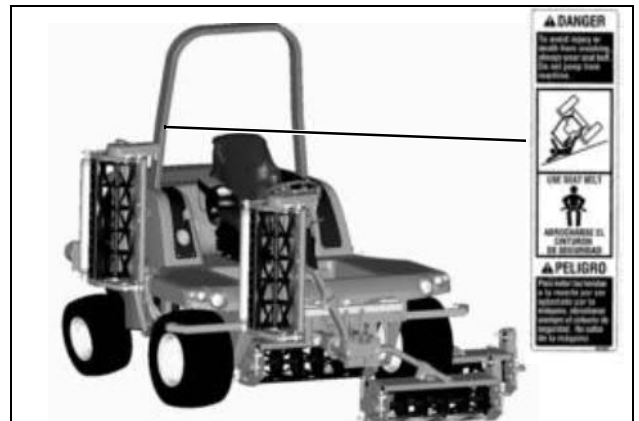

MT4391 / DM1236

To avoid injury or death from crushing, always wear seat belt. Do not jump from machine. Use seat belt.

## ROLL-OVER PROTECTIVE STRUCTURE

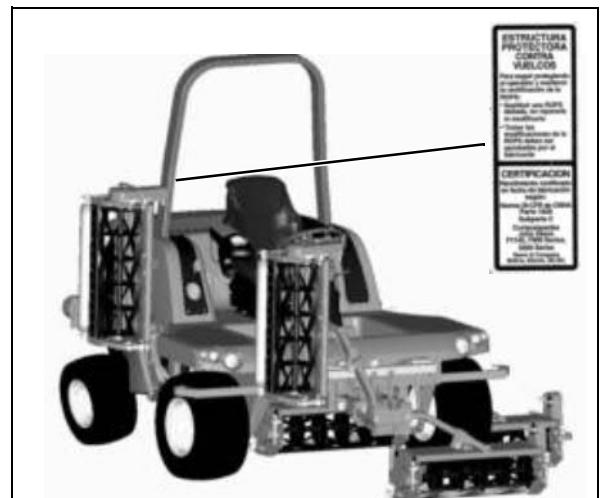

MT134364 / DM1236

Thank you so much for reading.  
Please click the “Buy Now!”  
button below to download the  
complete manual.



After you pay.

You can download the most  
perfect and complete manual in  
the world immediately.

Our support email:

[ebooklibonline@outlook.com](mailto:ebooklibonline@outlook.com)