

FORAGE HARVESTER 72 & ENSILAGE HARVESTER 74



JOHN DEERE

OPERATORS MANUAL FORAGE HARVESTER 72 & ENSILAGE HARVESTER 74

OME14152 A2 English

OME14152 A2

LITHO IN THE U.S.A.
ENGLISH



INTRODUCTION

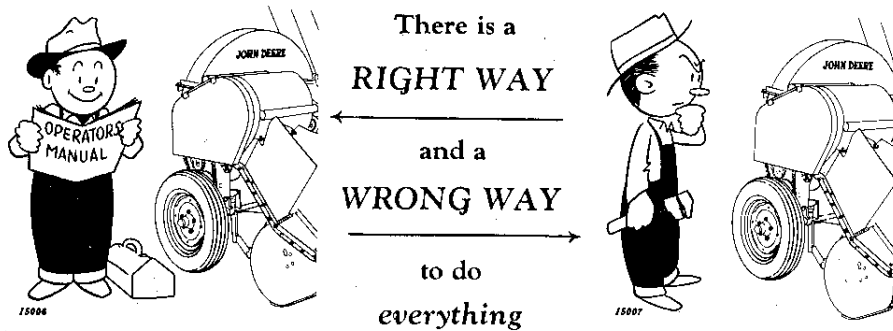

Your new John Deere No. 72 Forage Harvester and No. 74 Ensilage Harvester is a dependable machine, but only by proper care and operation can you expect to receive the service and long life designed and built into it. Like any precision machine, your Harvester will require a certain amount of attention at regular intervals. When any questions arise regarding lubrication, operation, or maintenance, use your manual as a guide to service your machine the **RIGHT WAY**.

If you find yourself in need of additional information or special servicing not covered in this manual, see your John Deere dealer. He is in a position to answer your questions for you, or to secure the correct information.

When in need of parts either to replace worn parts or to make emergency repairs, see your local John Deere dealer; he and the John Deere branch house behind him are equipped to render prompt service during the long life of your Harvester.

When ordering parts, give your Harvester serial number as well as the part number and description provided in the parts list of this manual. This information will help him to give you prompt and efficient service.

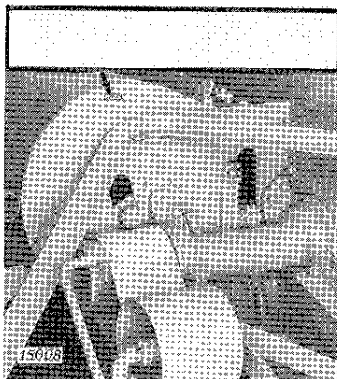

The serial number of your machine is located on the top left side of the roller box. (Record it in the space at the left.)

TABLE OF CONTENTS

	<i>Page</i>
SPECIFICATIONS AND DATA	4
OPERATION	5-12
Description	5
Hook-Up Instructions	6
General Operating Instructions	7
Operation—No. 72	8
Operation—No. 74	9
Discharge Spout	10
Transporting	11
Safety First	12
LUBRICATION	13-16
Lubrication—No. 72	13-14
Lubrication—No. 74	15-16
ATTACHMENTS	17-24
Tractor Hookup Equipment	17
Pickup Attachment	18
Row-Crop Attachment	18
Wisconsin Engine and Mounting	19
Continent Engine and Mounting	19
Knife Grinder	20-21
Powr-Trol Adapter	22
Discharge Spout Extension	23
High Discharge Spout	23
Trash Remover	24
Feed Roll Belts	24
Slip Clutch Shield	24
ADJUSTMENTS AND SERVICE	25-38
Adjustments—Nos. 72 and 74	25-34
Adjustments—No. 72 Only	35
Adjustments—No. 74 Only	36-38
ASSEMBLY	39-47
PARTS LIST	48-114
Using the Parts List	48
Index to Parts List	49
Parts List and Illustrations	50-108
Numerical Index	109-114

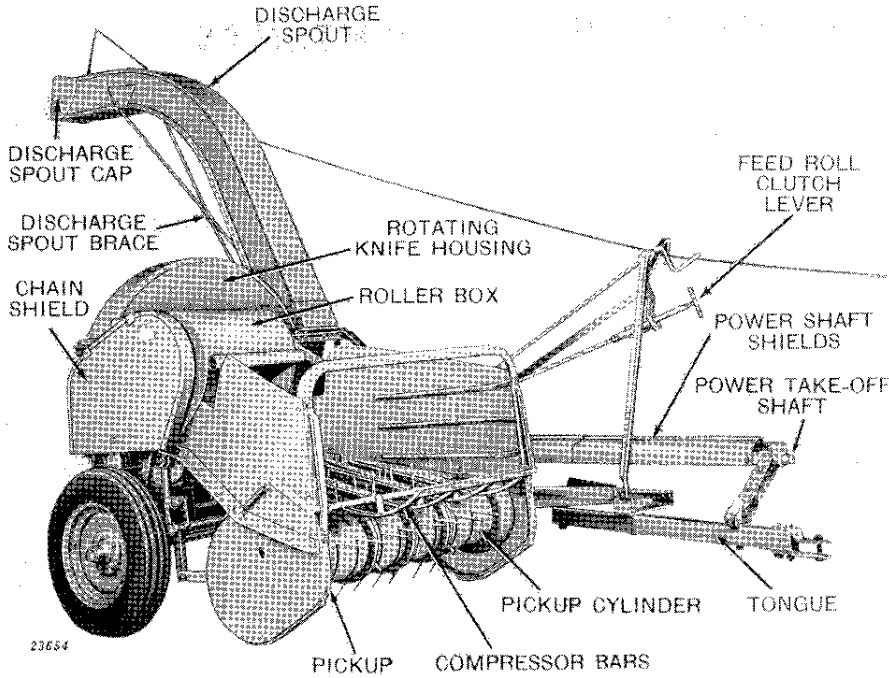

**Figure 1—Right-Hand View of No. 72 Forage Harvester
Power Take-Off with Rear Delivery**

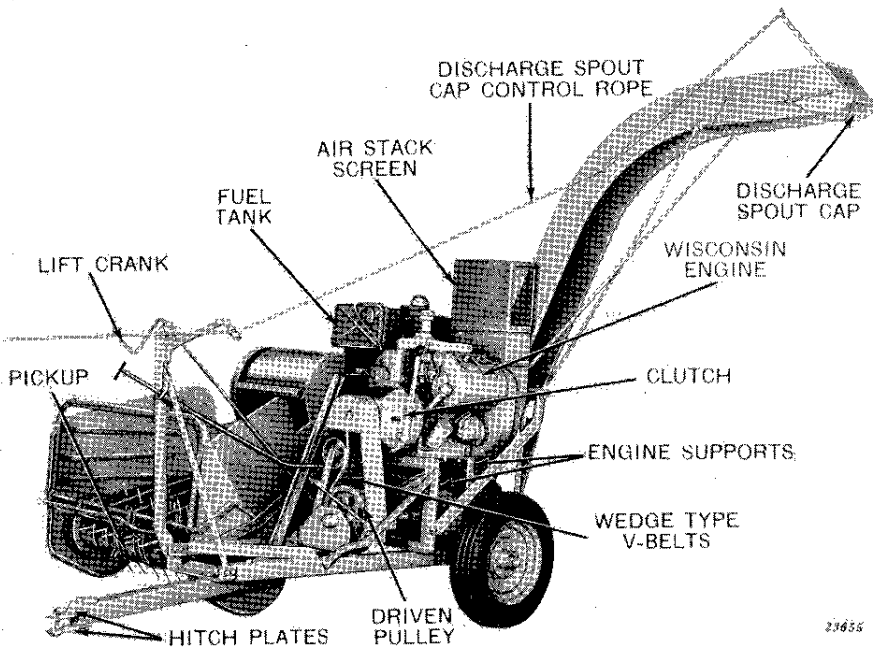

**Figure 2—Left-Hand View of No. 72 Forage Harvester
Wisconsin Engine Mounted with Side Delivery**

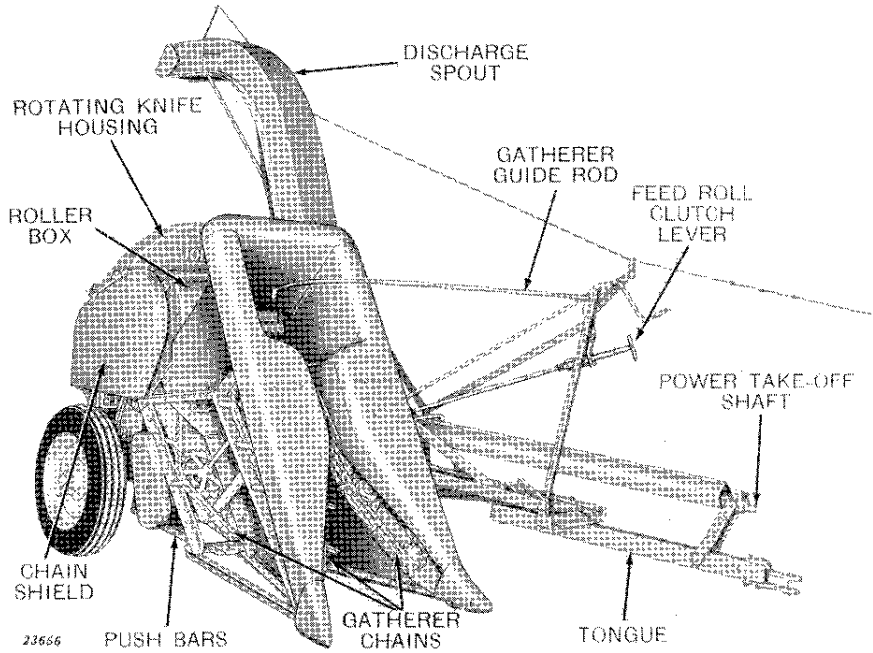

**Figure 3—Right-Hand View of No. 74 Ensilage Harvester
Power Take-Off with Rear Delivery**

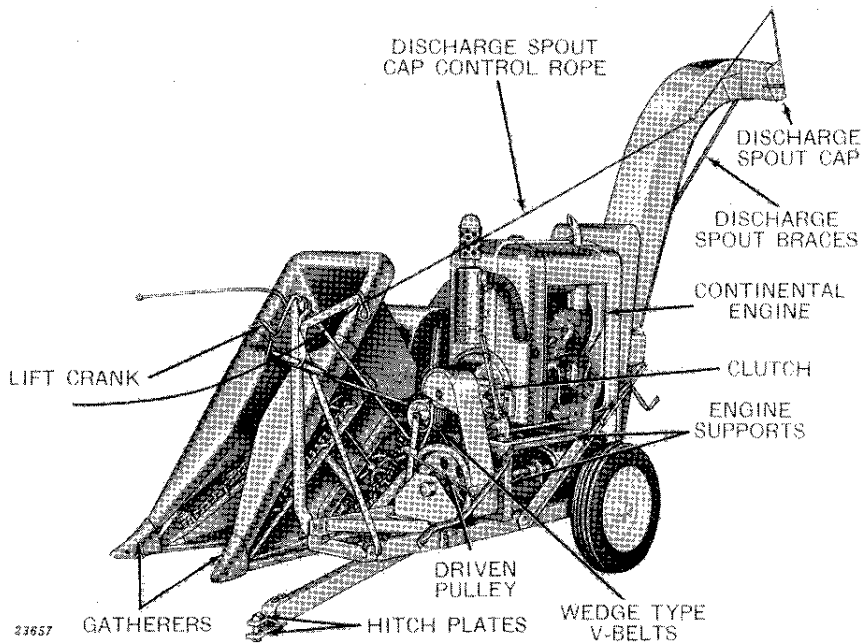

**Figure 4—Left-Hand View of No. 74 Ensilage Harvester
Continental Engine Mounted with Rear Delivery**

Thank you so much for reading.
Please click the “Buy Now!”
button below to download the
complete manual.



After you pay.

You can download the most
perfect and complete manual in
the world immediately.

Our support email:

ebooklibonline@outlook.com