

# 25A Flail Mower

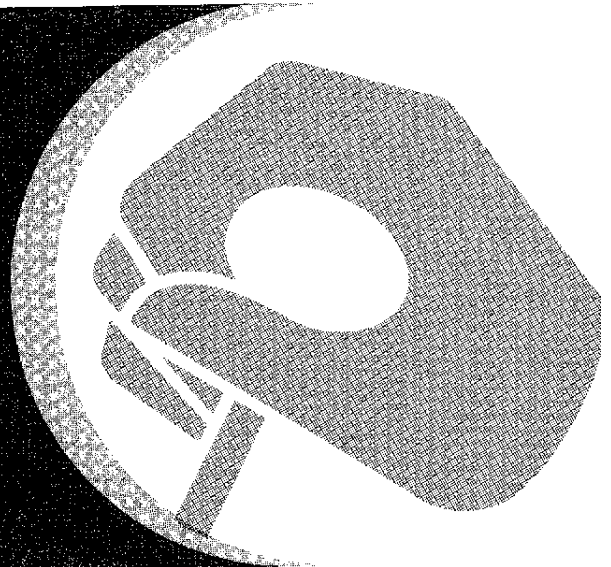

**Ottumwa Works**  
**OM-E41579 Issue K6**  
LITHO IN U.S.A.



## To the Purchaser

---

Your new mower was carefully designed and manufactured to give years of dependable service. To keep it running efficiently, read the instructions in this operator's manual. Each section is clearly identified so you can easily find the information you need - whether it is operation, lubrication, or service. Read the Table of Contents to learn where each section is located. Use the Alphabetical Index for fast reference.

 This safety alert symbol identifies important safety messages in this manual. When you see this symbol, be alert to the possibility of personal injury and carefully read the message that follows.

"Right-hand" and "left-hand" sides of the machine are determined by facing in the direction the mower will travel when in use.

Because John Deere sells its products world-wide, U.S. units of measure are shown with their respective Metric equivalents throughout this operator's manual. These equivalents are the SI (International System) Units of Measure.

Record your mower serial number in the space provided on page 11. Your dealer needs this information to give you prompt, efficient service when you order parts. If your mower requires replacement parts, go to your John Deere dealer where you can obtain Genuine John Deere parts—accept no substitutes.

The warranty on this mower appears on your copy of the purchase order which you should have received from your dealer when you purchased the mower.



# Contents

	Page
Identification View .....	1
Safety suggestions .....	2
Operation .....	3
Storage .....	6
Lubrication .....	7
Service .....	8
Attachments .....	10
Specifications .....	11
Index .....	12

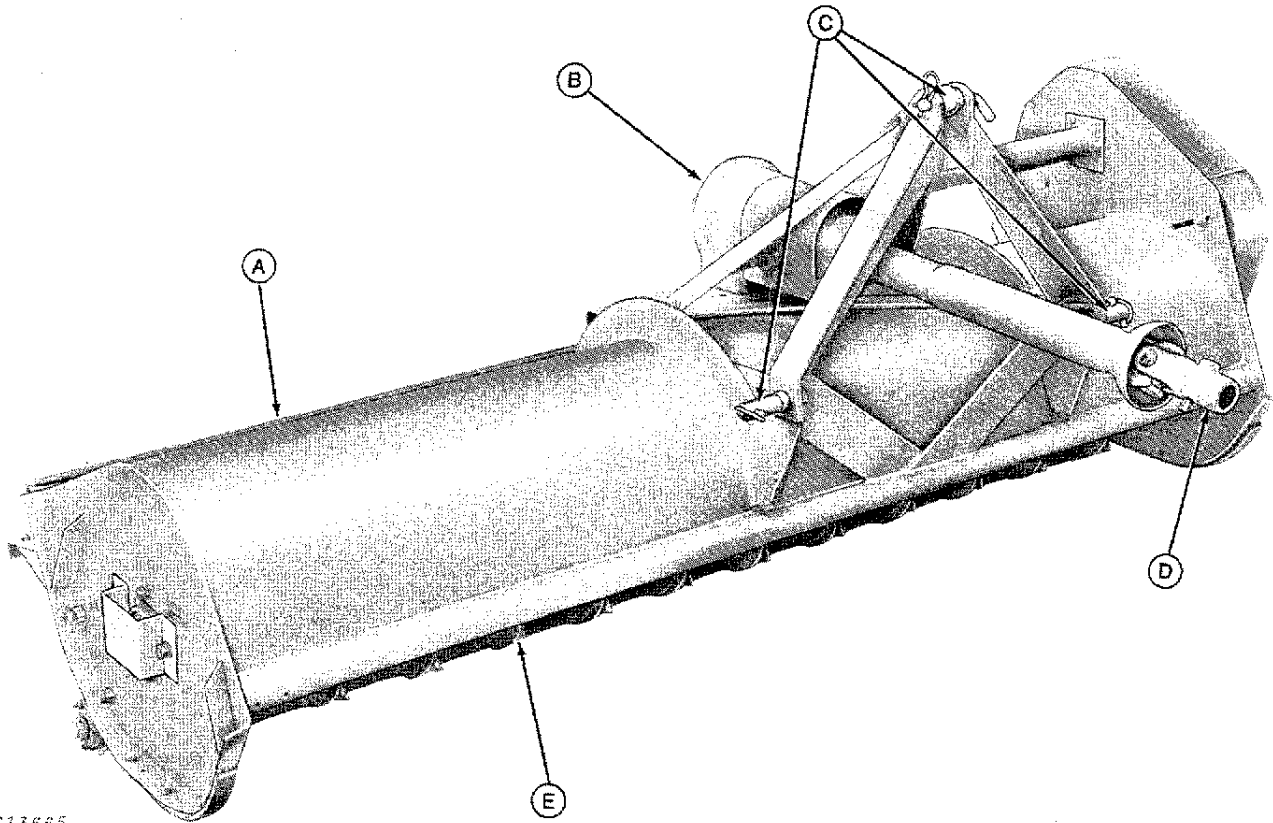

E13885

A—Floating Deflector

B—Gear Case

C—3-Point Hitch

D—Tractor Hookup

E—Rotor Knife

Front View of 25A Mower



# Safety Suggestions

---

**!** The safety of the operator was one of the prime considerations in the minds of John Deere engineers when this mower was designed. Shielding, simple adjustments, and other safety features were built into the mower wherever possible.

You can make your farm a safer place to live and work if you observe the safety suggestions given. Study these suggestions carefully and insist they be followed by those working with you and for you.

All machinery should be operated only by responsible persons who have been delegated to do so.

Before servicing or adjusting the mower, or removing material from it, always:

1. disengage all power,
2. shut off tractor engine, and then
3. wait until knives have stopped rotating.

Always operate tractor with PTO master shield securely installed.

Use caution in handling any type of engine fuel.

Stand clear of mower at all times when machine is operating.

Do not attempt to remove material when machine is running.

Never operate 540 rpm mower with 1000 rpm tractor.

Before starting the mower, check the hookup universal joint through the complete lifting range of the hydraulic system to be sure there is no binding, bottoming, or uncoupling of the joint.

Always disengage power and shut off tractor engine before dismounting from tractor.

Clothing worn by the mower operator should be fairly tight and belted. Loose jackets, shirts, or sleeves should never be worn because of the danger of getting into moving parts.

Be especially careful when operating on hillsides. The tractor may tip sideways if it strikes a hole, ditch, or other irregularity.

Keep hands, feet, and clothing away from moving parts.

Do not transport at high speeds, especially when traveling over rough fields or roads.

Always have safety shields in place while operating.

Before working underneath mower, place blocks under each end of frame to prevent accidental lowering of machine. Disengage power and make sure all moving parts have stopped before servicing machine.

Never clean, oil, or adjust the mower when it is in motion.

Always lower 3-point hitch when shutting tractor off.

When transporting the mower on a road or highway at night or during the day, use accessory lights and devices for adequate warning to the operators of other vehicles. In this regard, check local governmental regulations. Various safety lights and devices are available from your John Deere dealer.

Be alert; the life you save could be your own.

**Buy Now**



Our support email:

[ebooklibonline@outlook.com](mailto:ebooklibonline@outlook.com)