

OPERATOR'S CAB FOR 5200 AND 5400 SELF-PROPELLED FORAGE HARVESTERS



JOHN DEERE

OPERATORS MANUAL OPERATOR'S CAB FOR 5200 AND 5400 SELF-PROPELLED FORAGE HARVESTERS

OME55681 L3 English

OME55681 L3

LITHO IN THE U.S.A.
ENGLISH





To the Purchaser

Your new operator's cab was carefully designed and manufactured to give years of dependable, comfortable service. To get the most satisfaction from it, read the instructions in this operator's manual. Each section is clearly identified so you can easily find the information you need—whether it is operation or service. Read the Table of Contents to learn where each section is located.

 This safety alert symbol identifies important safety messages in this manual. When you see this symbol, be alert to the possibility of personal injury and carefully read the message that follows.

Study this manual carefully, keep it handy with your regular harvester operator's manual, in a safe place, for future reference.

If you find that you require information not covered in this manual, see your John Deere dealer. He will answer any questions regarding the operation and service of the operator's cab. He has trained mechanics who are kept informed on the best method of

John Deere servicing and can give you prompt know-how service in the field or in his shop.

Should your operator's cab require replacement parts, see your John Deere dealer where you will receive John Deere parts—accept no substitutes. John Deere parts fit properly and insure satisfactory service because they are made from original patterns and from the same material as the new machines.

“Right-hand” and “left-hand” sides are determined by facing in the direction the harvester will travel when in use.

The warranty on this operator's cab appears on your copy of the purchase order which you should have received from your dealer when you purchased your forage harvester.

Record the date purchased in the space provided on page 33. Your dealer needs this information to give you prompt, efficient service when you order parts.

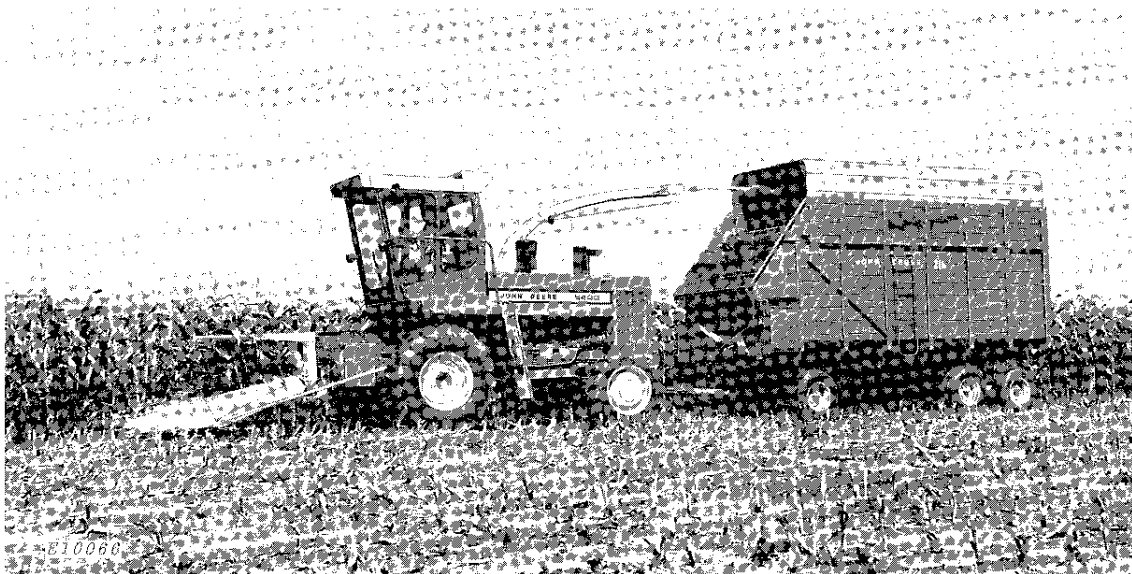



Contents

	Page
Identification View	1
Operation	2
Service	7
Trouble Shooting	12
Attachments	17
Assembly	18
Specifications	33
Index	34



John Deere Harvester Operator's Cab



Operation

CONTROLS

The operator's cab controls are conveniently located in the cab headliner to the front and side of the operator.

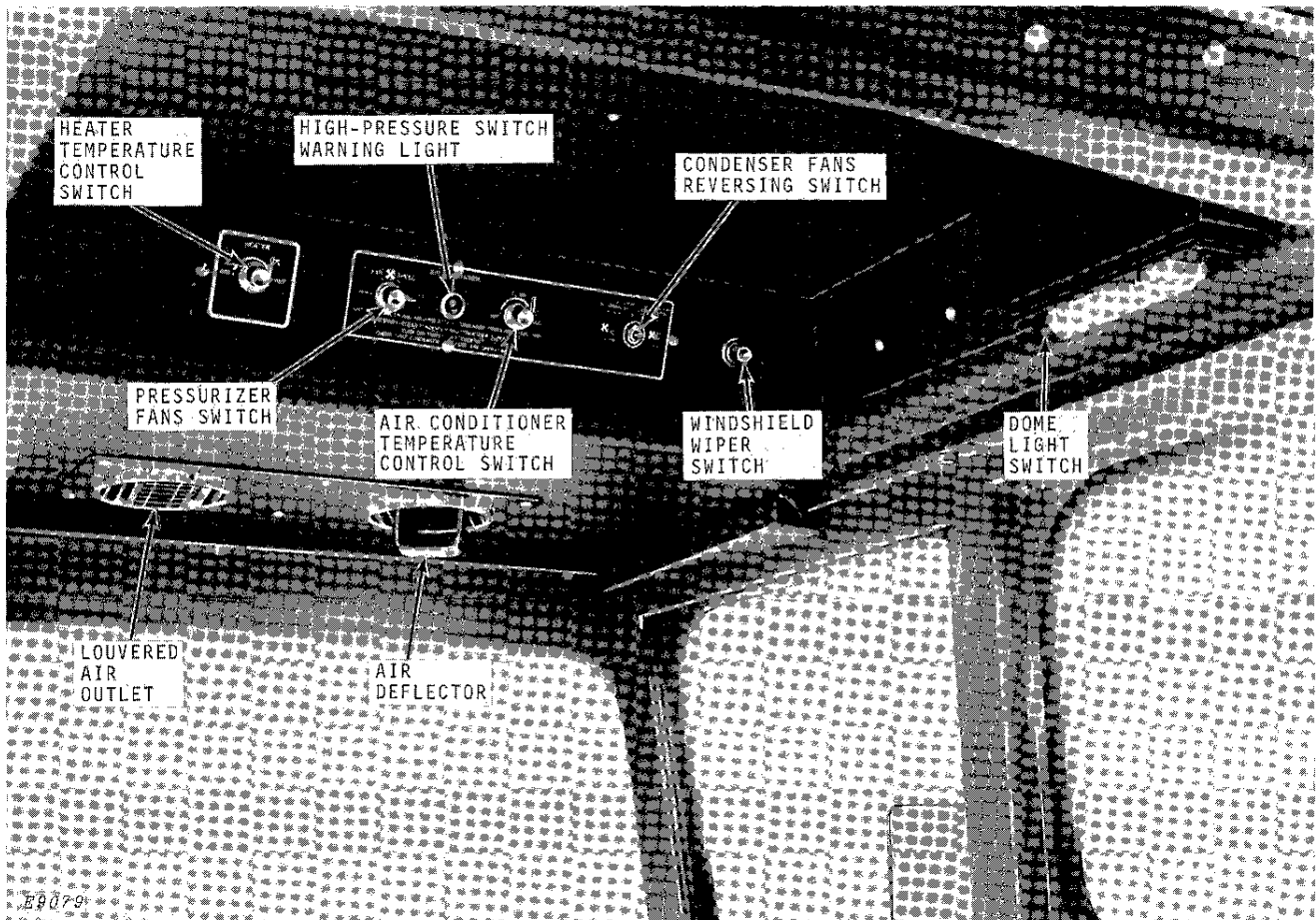

Heater Temperature Control Switch

The amount of heat in the cab is controlled by turning the heater control switch clockwise, from the "OFF" position toward the "HOT" position. Turning the switch all the way to the "HOT" position will provide maximum heating.

Pressurizer Fans Switch

This switch controls the fans which pressurize the cab. This is a three-speed switch with the highest speed obtained by turning the switch clockwise as far as it will go.

IMPORTANT: Pressurizer fans must be operating whenever the heater or air conditioner is in use.

High-Pressure Switch Warning Light

This light will glow red when the high-pressure switch has activated indicating that it may be necessary to clean the condenser. See page 9.

Air Conditioner Temperature Control Switch

The air conditioner temperature control switch is a thermostatic-type switch which will maintain the desired temperature.

Cool air in the cab is controlled by turning the air conditioner temperature control switch from the "OFF" position clockwise toward the "COLD" position. Turning the switch all the way to the "COLD" position will provide maximum cooling.

Condenser Fans Reversing Switch

When pushed to the right, this toggle-type switch will reverse the three condenser fans located in the cab roof. When released, it will automatically return to normal operating position.

IMPORTANT: Operate this reversing switch once every hour of operation for approximately 30 seconds, to clean the condenser core of any dirt or chaff.

Windshield Wiper Switch

This is a two-speed switch. Turning the switch clockwise to the first detent will give normal wiper operation. The second detent position will produce a faster wiper action. When the switch is turned all the way counterclockwise, the wiper will return to its stop position.

Dome Light Switch

Moving this toggle-type switch to the right turns the dome light on; moving this switch to the left turns the light off.

Louvered Air Outlets

The air outlets are adjustable, enabling the operator to control the flow of air into the cab. The outlets can be turned 360 degrees. One of the air outlets is equipped with an air deflector to further control air flow.

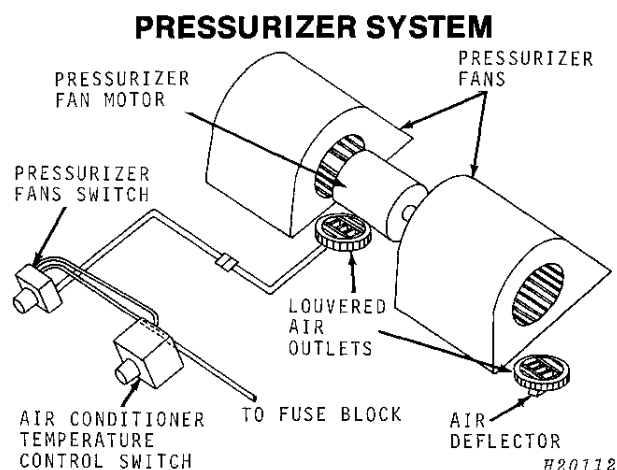

The pressurizer system is made up of two rotating cage-type fans, an electric motor, two louvered air outlets, an air deflector (snapped into one of the air outlets) and a control switch.

The pressurizer fans, when activated by the control switch, increase the pressure inside the cab. With a higher pressure inside the cab, air and dust will not move from outside the cab to inside the cab.

The louvered air outlets are also used to direct air flow from the air conditioner and heater.

IMPORTANT: The pressurizer system must be in operation when the air conditioner or heater is in use.

Thank you so much for reading.
Please click the “Buy Now!”
button below to download the
complete manual.



After you pay.

You can download the most
perfect and complete manual in
the world immediately.

Our support email:

ebooklibonline@outlook.com