

Lawn Tractors

S2546

Serial No. (020,001-)



Limited Edition

OPERATOR'S MANUAL

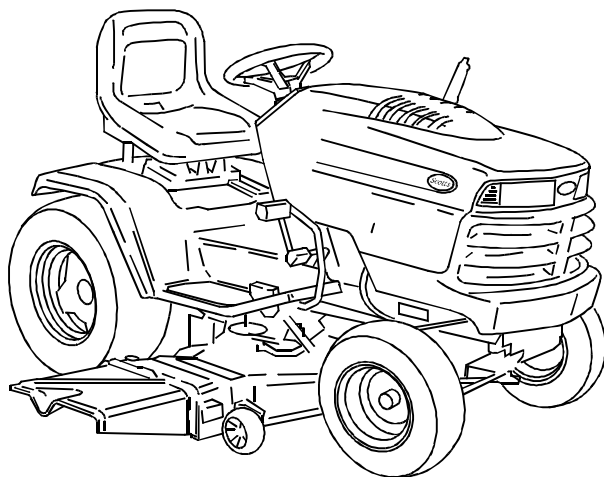

OMGX10545 F9

North American Version
Litho in U.S.A.

English

INTRODUCTION

THANK YOU for purchasing a Scotts product.

Read this manual and your attachment manual thoroughly. Failure to do so could result in personal injury or equipment damage.

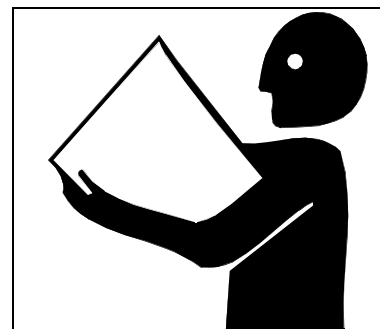

WARNING: The Engine Exhaust from this product contains chemicals known to the State of California to cause cancer, birth defects or other reproductive harm.

CALIFORNIA Proposition 65 Warning

This manual should be considered a permanent part of your machine and should remain with the machine when you sell it.

Measurements in this manual are metric units and their U.S. customary equivalents. RIGHT-HAND and LEFT-HAND sides are determined by facing in the direction the machine will travel when going forward. When you see a broken line arrow (----->), it indicates the part it is pointing to is hidden.

Record identification numbers below. Be sure to record all the numbers to help in tracing the machine if it is stolen. You also need to give these numbers to your dealer when you order parts.

DATE OF PURCHASE: _____

DEALER NAME: _____

DEALER PHONE: _____

TRACTOR SERIAL NUMBER (A), (Under seat):

ENGINE SERIAL NUMBER (B), (Right side of engine):

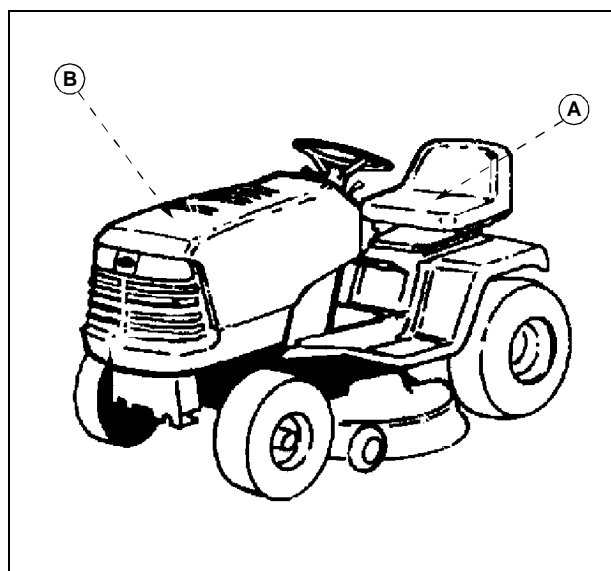

TABLE OF CONTENTS

Assembly	1
Safety Signs.....	4
Controls	6
Operating the Machine	7
Operating the Mower	23
Replacement Parts	29
Service Machine Safely	30
Service Interval Chart.....	32
Service Engine	34
Service Steering and Brakes	41
Service Mower.....	43
Service Electrical.....	49
Service Miscellaneous.....	55
Removing Mower.....	62
Installing Mower.....	64
Troubleshooting	66
Storing Machine.....	71
Specifications.....	74
Warranty	76
Index.....	82
Service Literature	85

All information, illustrations and specifications in this manual are based on the latest information at the time of publication. The right is reserved to make changes at any time without notice.

COPYRIGHT© 1999
Deere & Co.
John Deere Worldwide Commercial and
Consumer Equipment Division
Horicon, WI
All rights reserved

OMGX10545 F9

ASSEMBLY

Identify Parts

NOTE: There is an extra ignition key strapped to one of the seat suspension springs.

Bag of Parts:

- Operator's Manual
- Safety Video
- Key Chain
- Padded Key
- Hardware for Battery Cables

Check and Connect Battery



CAUTION: Prevent Battery Explosions:

- Keep sparks, lighted matches, and open flame away from the top of battery. Battery gas can explode.
- Never check battery charge by placing a metal object across the posts. Use a voltmeter or hydrometer.
- Do not charge a frozen battery; it may explode. Warm battery to 16° C (60° F)



Check Battery

Battery is filled with acid and charged when it left the factory. If necessary, charge the battery prior to delivery.

Locate label attached to battery. Find the service expiration date information (A).

If battery is put into service after date shown, charge the battery for a minimum of 1 hour at 6 - 10 amps.

Check battery voltage. Battery is fully charged at 12.6 volts.

Make sure battery is installed with the NEG (negative) side of the battery to the left and POS (positive) side of battery to the right. Battery should be held down securely with the battery hold-down strap.



ASSEMBLY

Connect Battery

1. Remove and discard the RED positive (+) protective cap from the positive (+) battery terminal.
2. Connect RED positive (+) cable (A) to the battery POS (positive) terminal with carriage bolt and wing nut. Tighten securely. Apply petroleum jelly or silicone spray to terminal to prevent corrosion. Install the red terminal cover.
3. Remove and discard the BLACK (-) protective cap from the negative battery terminal.
4. Connect silver braided grounding cable (B) to the NEG (negative) terminal (C) with remaining carriage bolt and wing nut and tighten securely. Apply petroleum jelly or silicone spray to terminal to prevent corrosion.

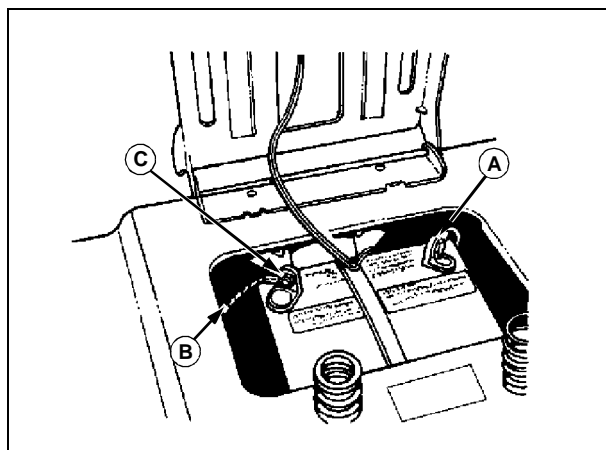

Check Tire Pressure

IMPORTANT: Tires are over-inflated during tractor assembly to improve bead sealing. During tractor set-up, be sure to check tire pressure and adjust if necessary.

Check tire pressure with an accurate gauge.

Adjust tire pressure to chart below:

Tire	Maximum Pressure
Front	97 kPa (14 psi)
Rear	69 kPa (10 psi)

Thank you so much for reading.
Please click the “Buy Now!”
button below to download the
complete manual.



After you pay.

You can download the most
perfect and complete manual in
the world immediately.

Our support email:

ebooklibonline@outlook.com