

**110-, 132-, AND
154-INCH THREE-
ROLLER BELT
PICKUPS AND 212 AND 214
PICKUP PLATFORMS**



JOHN DEERE

OPERATORS MANUAL

110-, 132-, AND 154-INCH THREE- ROLLER BELT
PICKUPS AND 212 AND 214 PICKUP PLATFORMS

OMH114169 J2 English

**HARVESTER WORKS
OMH114169 J2**

LITHO IN THE U.S.A.
ENGLISH



INTRODUCTION

 This safety alert symbol identifies important safety messages in this manual. When you see this symbol, be alert to the possibility of personal injury and carefully read the message that follows.

The operator's manual contains SI Metric equivalents which follow immediately after the U.S. customary units of measure.

“Right-hand” and “left-hand” sides are determined by facing in the direction the belt pickup will travel when in use.

Record your belt pickup serial number in the space provided on page 53.

The warranty on this belt pickup appears on your copy of the purchase order which you should have received from your dealer when making your purchase. This warranty provides you the assurance that John Deere will back its products where defects appear within the warranty period. In some circumstances, John Deere also provides field improvements, often without charge to the customer, even if the product is out of warranty.

Warranty and field improvements are a part of John Deere's product support program for customers who operate and maintain their equipment as described in this manual. Should the equipment be abused, or modified to change its performance beyond the original factory specifications, the warranty will become void and field improvements may be denied.

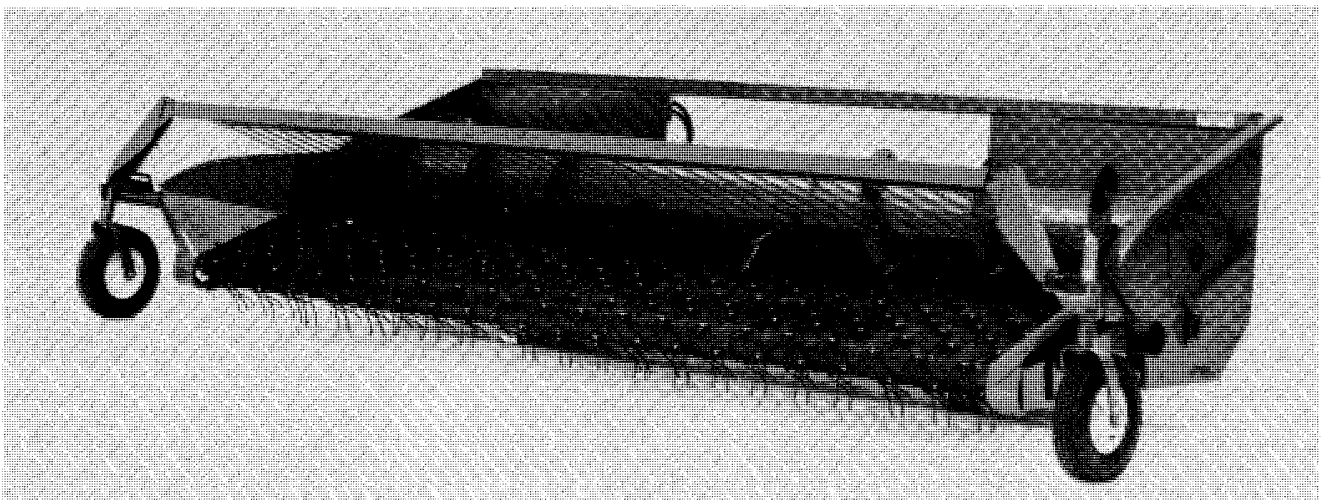

214 Belt Pickup Illustrated

H50130



Contents

| | Page | | Page |
|--|-------|---|-------|
| SAFETY SUGGESTIONS | 2-3 | STORAGE | 29 |
| ATTACHING AND DETACHING | 4 | ASSEMBLY AND INSTALLATION | 30-51 |
| Attaching Platform to 4400, 4420, 6620 | | Support Arms, Belts, and Hold-Down | 30,31 |
| 7720, 7721, and 8820 Combines | 4-6 | Preparing 6601 Platform for Belt Pickup | 32 |
| Attaching Platform to SideHill 6600, | | Mechanical Drive | 32 |
| and SideHill 6620 Combines | 7-10 | Installing Stripper Support Plate | 33 |
| TRANSPORTING | 11 | Installing Belt Pickup | 33,35 |
| OPERATING THE PLATFORM | 12-17 | Installing Mechanical Drive Parts | |
| Pickup Speed | 13 | and Shields | 35-38 |
| Mechanical Drive (6601) | 13 | Preparing 200 Series Rigid Platform | |
| Hydrostatic Drive | 13 | for Belt Pickup | 39-51 |
| Pickup Pitch | 14 | Installing Belt Pickup Diagrams | 44 |
| Normal Windrow Conditions | 14 | Installing Stripper Support Plate | 42 |
| Poor Windrow Conditions | 15 | Installing Hydrostatic Drive Parts | 45,46 |
| Rocky Conditions | 15 | Preparing Pickup Platform for Belt | |
| Pickup Height | 16 | Pickup | 47-49 |
| Adjusting Gauge Wheels | 16 | Installing Auger Flight Extensions | 49 |
| Adjusting Windrow Hold-down | 16 | Installing Hydrostatic Drive Parts | 50,51 |
| 6601 | 17 | SPECIAL EQUIPMENT | 52 |
| 200 Series and Belt Pickup | 17 | SPECIFICATIONS | 53 |
| LUBRICANTS | 18 | | |
| LUBRICATION AND MAINTENANCE | 19-20 | | |
| TROUBLE SHOOTING | 21 | | |
| SERVICE | 22-28 | | |
| Connecting Hydrostatic Drive Hoses | 22 | | |
| Tightening Hydrostatic Pump Drive Belt | 22-23 | | |
| Adjusting Pickup Drive Belt (6601) | 24 | | |
| Adjusting Pickup Drive Chain | 24 | | |
| Adjusting Lower Roller Drive Chain | 24 | | |
| Pickup Belts | 25 | | |
| Adjusting Tension | 25 | | |
| Removing Belts | 26 | | |
| Installing Belts | 26 | | |
| Installing Lacing | 26 | | |
| Replacing Pickup Fingers | 27 | | |
| Stripper | 28 | | |
| Tire Inflation | 28 | | |



Safety



Unauthorized modifications to the pickup may impair the function and or safety and affect machine life.

SAFETY DECALS



H28488N



CAUTION OR WARNING: Decals with these headings and symbol indicate the possibility of personal injury.

IMPORTANT: Decals with this heading indicate the possibility of damage to the machine.

Decals are located in areas where they apply.

AVOID CONTACT WITH MOVING PARTS

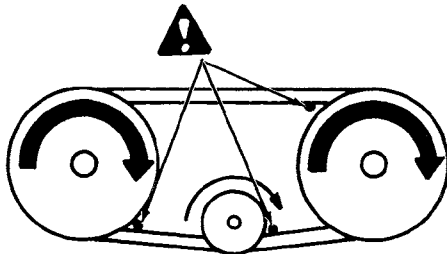

H36880

Keep hands, feet, and clothing away from power-driven parts. Be particularly careful of pinch points on belt and chain drives.

Never clean, lubricate, or adjust the pickup when it is running.

Never attempt to clear obstructions off the pickup unless the separator is disengaged and the power is shut off.

LEAVING COMBINE UNATTENDED

Before leaving the combine unattended, turn off engine and remove keys. Support the pickup with the hydraulic cylinder safety stop or lower it to the ground. Place the gearshift lever in neutral and engage the parking brake. Lock cab doors on 6620, SideHill 6620, 7720 and 8820 Combines.

OPERATE SAFELY

Clothing worn by operator must be fairly tight and belted. Loose jackets, shirts, or sleeves must never be worn.

Any time work is being done under pickup, the hydraulic cylinder safety stop must be placed in the safety position. Refer to page 5.

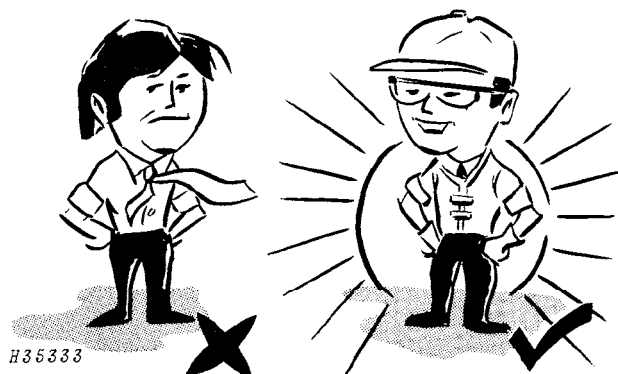

AVOID HIGH PRESSURE FLUIDS

Escaping fluid under pressure can penetrate the skin causing serious injury. Relieve pressure before disconnecting hydraulic or other lines. Tighten all connections before applying pressure. Keep hands and body away from pinholes and nozzles which eject fluids under high pressure. Use a piece of cardboard or paper to search for leaks. Do not use your hand.

If ANY fluid is injected into the skin, it must be surgically removed within a few hours by a doctor familiar with this type injury or gangrene may result.

Cracking hydraulic line fittings to lower the feeder house will result in an instantaneous dropping of feeder house or feeder house and header.



X9811

PROTECT AGAINST NOISE

Prolonged exposure to loud noise can cause impairment or loss of hearing.

Wear a suitable hearing protective device as earmuffs (A) or earplugs (B) to protect against objectionable or uncomfortable loud noises.



A — Earmuffs
B — Earplugs



Attaching and Detaching Platform

ATTACHING PICKUP PLATFORM TO 4400 (350001-), 6620, 7720, 7721 AND 8820 COMBINES

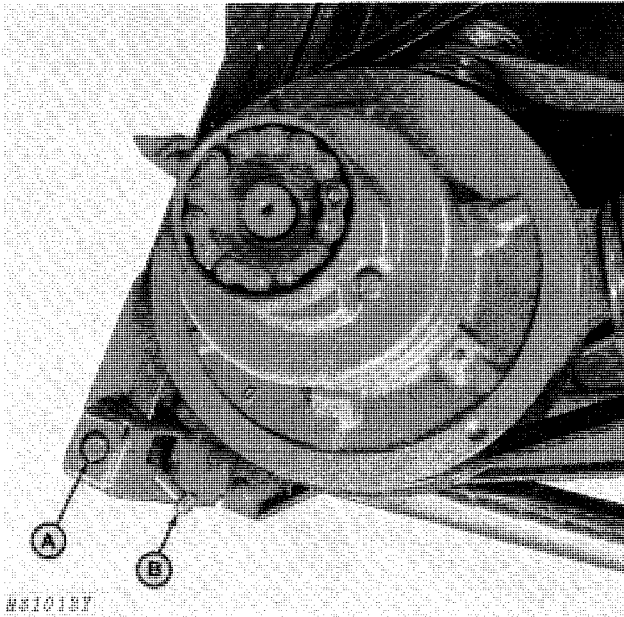

IMPORTANT: Lock pin (A) (both sides) must be positioned in before attaching header. Position pin by sliding stop bolt (B) in and pivoting it down. Damage to feeder house results when mounting header with pins in out position.

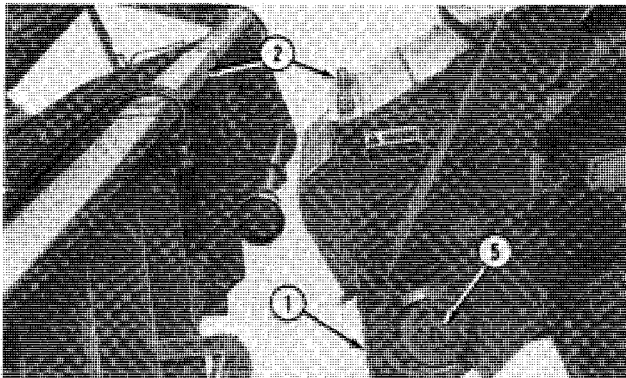

1. Start engine and lower feeder house.
2. Move combine slowly forward until feeder house is centered in platform opening. Raise feeder house, lifting platform, all the way up. Shut off engine.

3. Disconnect chain (A) and lower hydraulic cylinder safety stop (B) on lift cylinder.

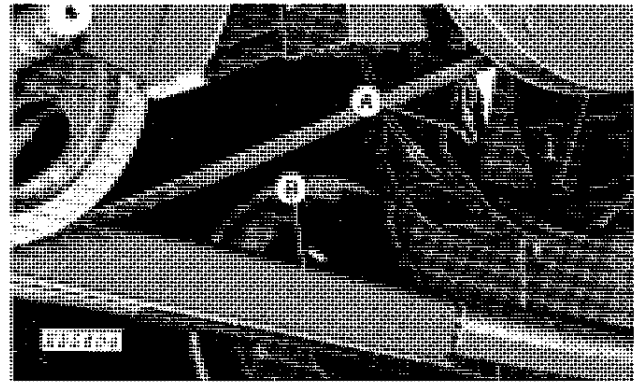

A — Support Chain
B — Safety Stop

4. Slide and pivot stop bolt (A) up and out, to move lock pin into header. Repeat procedure for other side.

NOTE: Loosen mating lock plate (B) on platform, to let lock pin lock and center into platform. Torque nut on lock plate (B) to 170 ft. lbs. (231 N•M). Repeat procedure on other side.

On 8820 combines, install coupler shipped with feeder house on L.H. platform drive shaft.

5. Place chain around sprockets and slide coupler over sprockets and chain. Repeat for other side.
6. Connect hoses for hydrostatic belt drive at couplers under operator's platform.

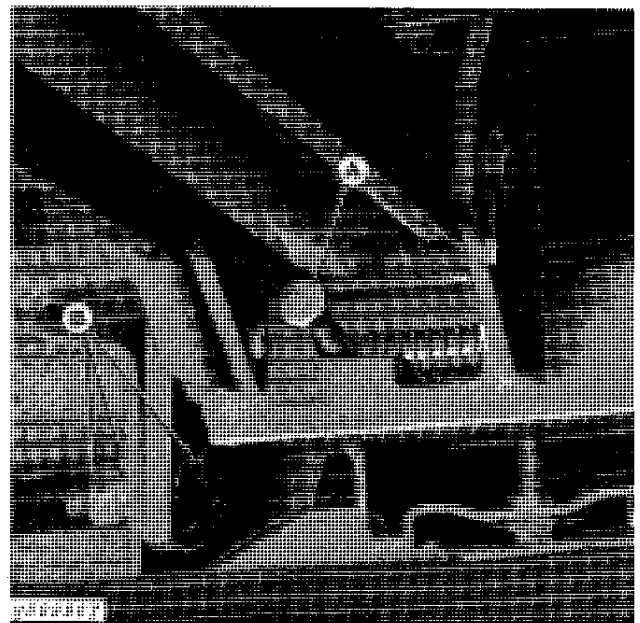

A — Pivot Stop Bolt
B — Mating Lock Plate

DETACHING PLATFORM FROM 4400 (350001-6620, 7720 and 8820 COMBINES), 4420,

1. Disconnect hoses for hydrostatic belt drive at couplers under operator's platform.

IMPORTANT: To prevent damage to hydraulic system connect hoses under operator's platform. These hoses stay with combine.

2. To prevent damage to variable speed feeder house hose if so equipped, when it is disconnected, route hose down between feeder house and variable-belt-drive and secure with clamp.
3. Start engine and raise pickup platform all the way up. Shut off engine.
4. Disconnect chain and lower hydraulic cylinder safety stop on lift cylinder.
5. Slide coupler off sprockets and chain and remove coupler chain.
6. Slide and pivot stop bolt in and down to unlock pin from platform. Repeat procedure on other side.
7. Raise hydraulic cylinder safety stop and hook chain.
8. Start engine and lower feeder house until belt pickup platform is on the ground and attaching blocks are free.
9. Move combine slowly rearward until feeder house is clear of belt pickup platform.

ATTACHING PICKUP PLATFORM TO SIDEHILL 6600 AND SIDEHILL 6620 (-358900)

1. Start engine and lower feeder house.
2. Move combine slowly forward until feeder house is centered in platform opening. Raise feeder house, lifting platform, all the way up. Shut off engine.

IMPORTANT: Pivot blocks on feeder house must be properly seated in pocket under top beam of header.

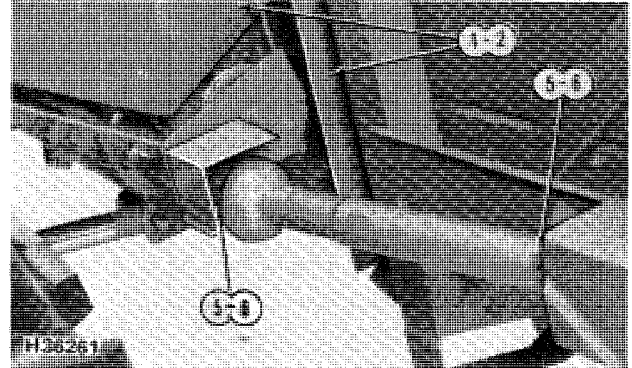

3. Disconnect chain (A) and lower hydraulic cylinder safety stop (B) on lift cylinder (C).

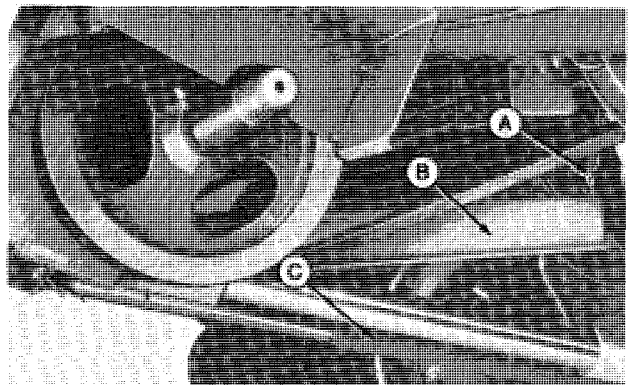

A — Support Chain
B — Safety Stop
C — Lift Cylinder

4. Secure platform to feeder house with two 5/8 x 1-1/2-inch round head bolts and 21/32 x 2 x .250-inch flat washers.
5. Install telescoping drive shaft between platform and feeder house by securing 5/16 x 2-1/2-inch cap screw (A) through platform shaft.
6. Take other end of telescoping drive shaft and secure it on feeder house drive shaft with 1/2 x 3-inch cap screw (B). (This clamps yoke to shaft).
7. Connect hoses for hydrostatic belt drive at couplers under operator's platform.
8. To prevent damage to variable speed feeder house hoses when disconnected, route hoses down between feeder house and variable-belt-drive and secure with clamps. Do not connect hoses together.

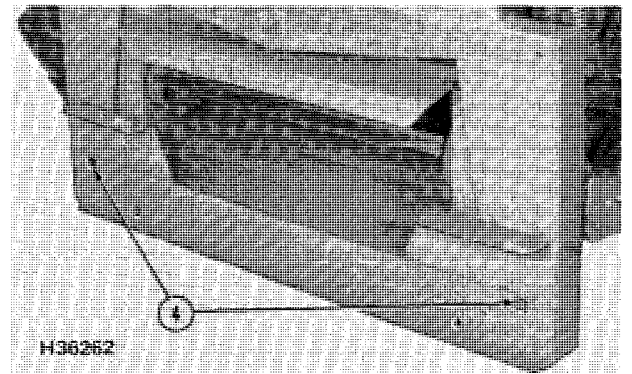

Feeder House Lower Attaching Plate Bolt Locations

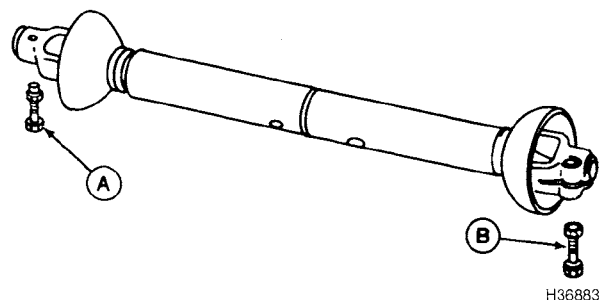

H36883

DETACHING PICKUP PLATFORM FROM SIDEHILL 6600 AND SIDEHILL 6620 (-358900) COMBINES

1. Disconnect hoses for hydraulic belt drive at couplers under operator's platform.

IMPORTANT: To prevent damage to hydraulic system connect hoses under operator's platform. These hoses stay with combine.

2. Start engine and raise pickup platform all the way up. Shut off engine.
3. Disconnect chain and lower hydraulic cylinder safety stop on lift cylinder.
4. Remove cap screws from both ends and disconnect telescoping drive shaft. Repeat procedure on other side.
5. Remove two 5/8 x 1-1/2-inch round head bolts and flat washers.
6. Raise hydraulic cylinder safety stop and hook chain.
7. Start engine and lower feeder house until platform is on the ground and attaching blocks are free.
8. Move combine slowly rearward until feeder house is clear of pickup platform.

ATTACHING PICKUP PLATFORM TO SIDEHILL 6620 (403301-) COMBINES

IMPORTANT: Lock pin (A) (both sides) must be positioned in before attaching header. Position pin by sliding stop bolt (B) in and pivoting it down. Damage to feeder house results when mounting header with pins in out position.

1. Start engine and lower feeder house.
2. Move combine slowly forward until feeder house is centered in pickup platform. Raise feeder house, lifting platform all the way up. Shut off engine.

IMPORTANT: Pivot blocks on feeder house must be properly seated in pocket under top beam of header.

3. Disconnect chain (A) and lower hydraulic cylinder safety stop (B) on lift cylinder (C).

A — Support Chain
B — Safety Stop
C — Lift Cylinder

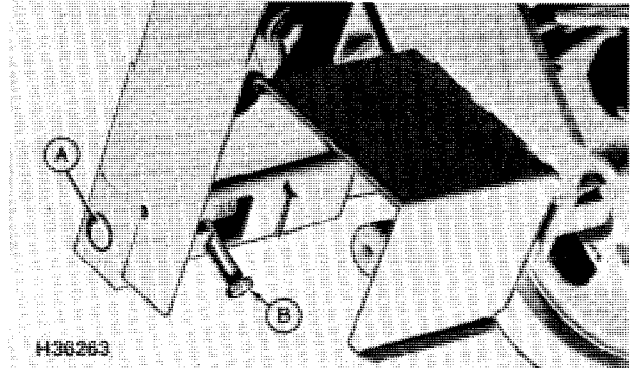

A — Lock Pin
B — Stop Bolt

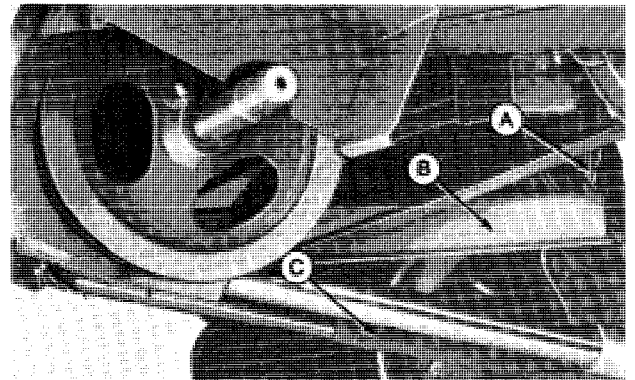

4. Slide and pivot stop bolt (A) up and out, to move lock pin into platform. Repeat procedure for other side.

NOTE: Loosen mating lock plate (B) on platform, to let lock pin lock and center into platform. Torque nut on lock plate (B) to 170 ft. lbs. (231N•M). Repeat procedure on other side.

A — Stop Bolt
B — Lock Plate

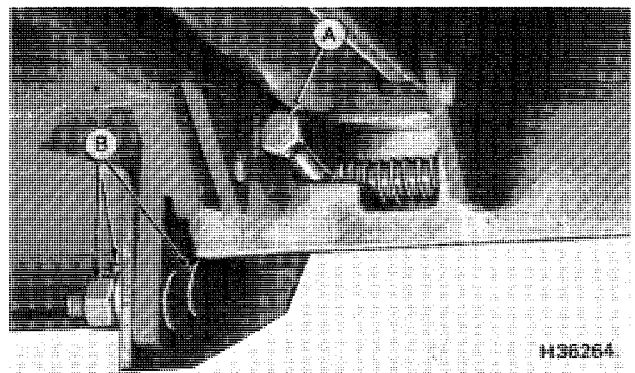

Thank you so much for reading.
Please click the “Buy Now!”
button below to download the
complete manual.



After you pay.

You can download the most
perfect and complete manual in
the world immediately.

Our support email:

ebooklibonline@outlook.com