

# 7701 Combines



## OPERATORS MANUAL

7701  
Combines

OMH98962 Issue B8 English

**Harvester Works**  
**OMH98962 Issue B8**

LITHO IN U.S.A.  
ENGLISH





# To The Operator



This safety alert symbol identifies important safety messages in this manual. When you see this symbol, be alert to the possibility of personal injury and carefully read the message that follows.

Your operator's manual contains SI metric equivalents which follow immediately after the U.S. customary units of measure.

"Right-hand" and "left-hand" sides are determined by facing in the direction the combine will travel when in use.

Record your combine serial numbers in the space provided on page 94.

The warranty on this combine appears on your copy of the purchase order which you should have received from your dealer when making your purchase. This warranty provides you the assurance that John Deere will back its products where defects appear within the warranty period. In some circumstances, John Deere also provides field improvements, often without charge to the customer, even if the product is out of warranty.

Warranty and field improvements are a part of John Deere's product support program for customers who operate and maintain their equipment as described in this manual. Should the equipment be abused, or modified to change its performance beyond the original factory specifications, the warranty will become void and field improvements may be denied.

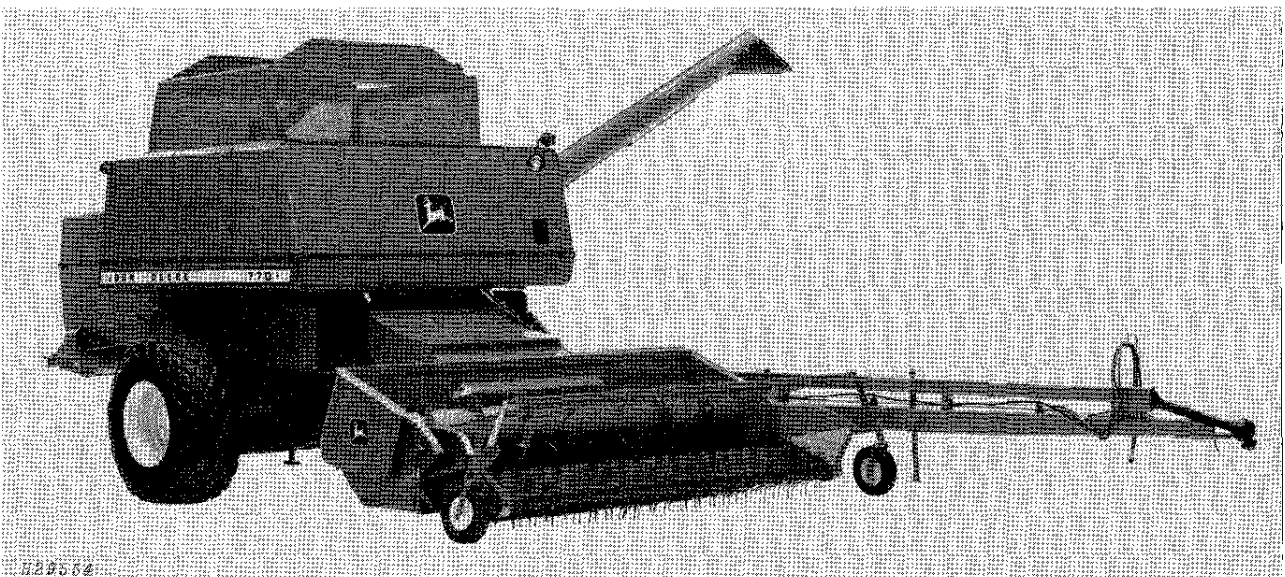



# Contents

---

	<b>Page</b>
Safety.....	2-4
Combine Function Controls.....	5
Preparing for Use.....	6
Preparing the Tractor.....	6-9
Preparing the Combine.....	10
Attaching Combine to Tractor.....	10
Hookup Adjustments.....	12
On John Deere Tractors.....	12
On Other Tractors.....	13
Field Lighting.....	14
Transporting.....	15-17
Operating the Combine.....	18-20
Controls on Tractor.....	18, 19
Controls on Combine.....	19, 20
Starting the Combine.....	20
Fundamentals of Combine Harvesting .....	21, 22
Field Adjustments.....	23-49
Cutting and Feeding.....	23-25
Threshing.....	25-28
Separating.....	29-33
Cleaning.....	34, 35
Crop Handling .....	35, 36
Belt, Chains, and Slip Clutches.....	37-43
Low Shaft Speed Monitor System (Optional).....	44, 45
Operating Speeds.....	46
Suggested Settings.....	47, 48
Seed Loss Chart.....	49
Lubrication.....	51-58
Service.....	59-84
Trouble Shooting.....	85-91
Storage.....	92, 93
Specifications.....	94-97
Serial Numbers.....	94
Index.....	98-100



# Safety

**!** Safety of the operator was one of the prime considerations in the minds of John Deere engineers when this combine was designed. Shielding, simple adjustments, and other safety features were built into the combine wherever possible. Modifications to the machine may also impair the function and or safety and affect machine life.

## AVOID CONTACT WITH MOVING PARTS

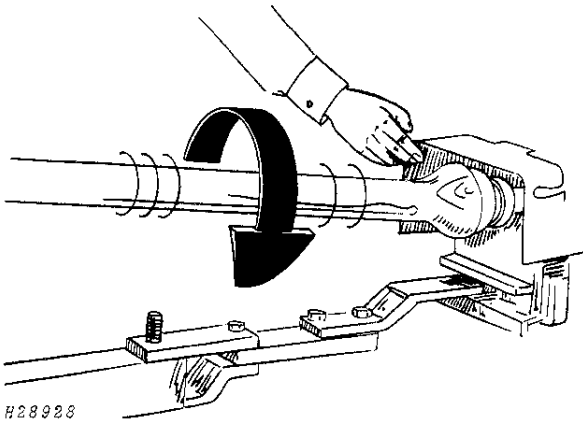

Keep guards and shields in place at all times while operating the combine. Always disengage tractor PTO and shut off engine before removing guards or shields.

Keep hands, feet, and clothing away from power-driven parts.

Never clean, lubricate, or adjust the combine when it is running.

Everyone must be clear before starting tractor engine or running combine.

Never attempt to clear obstructions off the header unless the PTO is disengaged and the tractor engine is shut off.

## OPERATE SAFELY

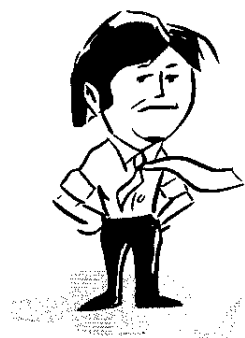

H28929

WRONG



RIGHT

Clothing worn by operator must be fairly tight and belted. Loose jackets, shirts, or sleeves must never be worn.

The gearshift lever of tractor must be in neutral and the PTO lever disengaged before starting tractor engine.

Be careful when operating on hillsides so the combine or tractor will not tip sideways.

Always keep the tractor in gear when going down hills.

## AVOID HIGH PRESSURE LEAKS

Escaping hydraulic fluid under pressure can have sufficient force to penetrate the skin, causing serious injury. Before disconnecting lines, relieve all pressure. Before applying pressure to the system, all connections must be tight and lines, pipes, and hoses must be in good condition.

Fluid escaping from a very small hole can be almost invisible. Use a piece of cardboard or wood, rather than hands, to search for suspected leaks.

If injured by escaping fluid, see a doctor at once. Serious infection or reaction can develop if proper medical treatment is not administered immediately.

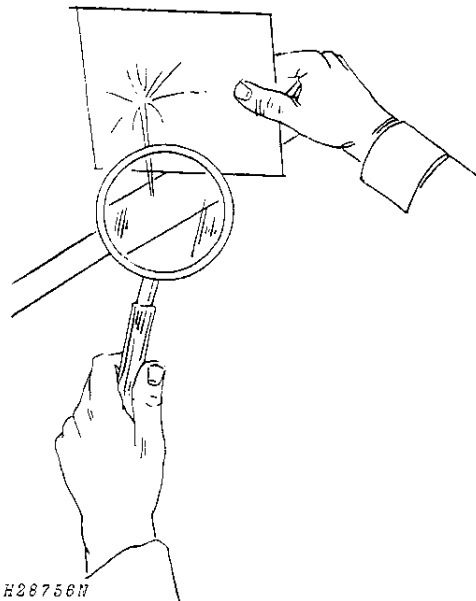

## LEAVING COMBINE UNATTENDED

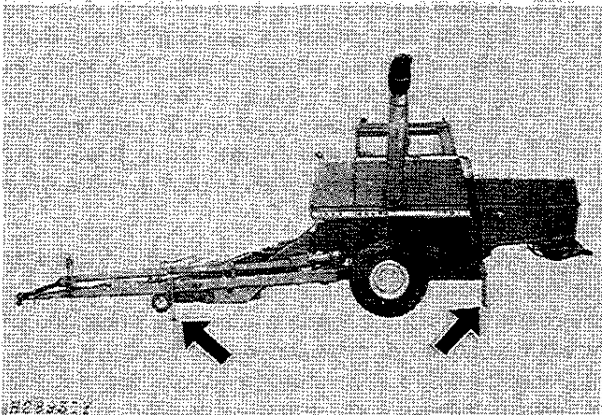

Before leaving the combine unattended, support the header with either the hydraulic cylinder safety stop or with blocks, or lower it to the ground.

Lower hitch and separator support stands.

## TRANSPORT SAFELY

Never ride or allow anyone on the tractor, drawbar, or hitch.

Be extra careful when transporting the combine in hilly country.

Use a tractor large enough to maintain control.

When transporting the combine on a road or highway, use accessory lights and devices for adequate warning to the operators of other vehicles. In this regard, check local governmental regulations.

Tow only with an agricultural tractor equipped with stationary drawbar.

Do not transport combine over 20 MPH (32.2 km/h).

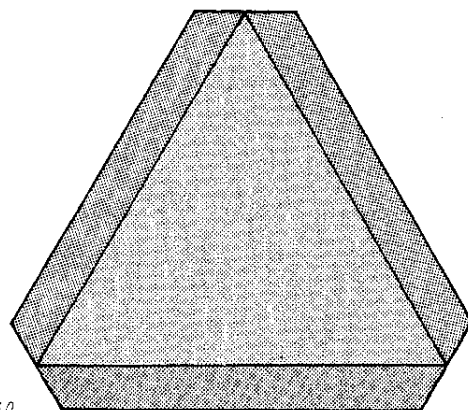

Thank you so much for reading.  
Please click the “Buy Now!”  
button below to download the  
complete manual.



After you pay.

You can download the most  
perfect and complete manual in  
the world immediately.

Our support email:

[ebooklibonline@outlook.com](mailto:ebooklibonline@outlook.com)