

JOHN DEERE
WORLDWIDE CONSTRUCTION
AND FORESTRY DIVISION

Cold Planer
CP12, CP16, CP18, & CP24

OMKV16792 K1

OPERATOR'S MANUAL



JOHN DEERE

North American Version
Litho in U.S.A.

INTRODUCTION

Thank You for Purchasing a John Deere Product

We appreciate having you as a customer and wish you many years of safe and satisfied use of your machine.

Using Your Operator's Manual

This manual is an important part of your machine and should remain with the machine at all times.

Reading your operator's manual will help you and others avoid personal injury or damage to the machine. Information given in this manual will provide the operator with the safest and most effective use of the machine. Knowing how to operate this machine safely and correctly will allow you to train others who may operate this machine.

This manual and safety signs on your machine may also be available in other languages (see your Authorized John Deere Skid Steer Dealer to order).

Sections in your operator's manual are placed in a specific order to help you understand all the safety messages and learn the controls so you can operate this machine safely. You can also use this manual to answer any specific operating or servicing questions. A convenient index located at the end of this book will help you to find needed information quickly.

The machine shown in this manual may differ slightly from your machine, but will be similar enough to help you understand our instructions.

RIGHT-HAND and LEFT-HAND sides are determined by facing in the direction the machine will travel when going forward. When you see a broken line arrow (----->), the item referred to is hidden from view.

Before delivering this machine, your dealer performed a predelivery inspection to ensure best performance.

Special Messages

Your manual contains special messages to bring attention to potential safety concerns, machine damage as well as helpful operating and servicing information. Please read all the information carefully to avoid injury and machine damage.

IMPORTANT: Avoid damage! This text is used to tell the operator of actions or conditions that might result in damage to the machine.

NOTE: Information is given throughout the manual that may help the operator with the operation or service of the machine.



CAUTION: Avoid injury! This symbol and text highlight potential hazards or death to the operator or bystanders that may occur if the hazards or procedures are ignored.

PRODUCT IDENTIFICATION

Record Identification Numbers

Cold Planers for Skid Steers

CP12 Serial No. (KVCP12X100100 -)

CP16 Serial No. (KVCP16X100100 -)

CP18 Serial No. (KVCP18X100100 -)

CP24 Serial No. (KVCP24X100100 -)

If you need to contact an Authorized Service Center for information on servicing, always provide the product model and identification numbers.

You will need to locate the identification number (A) for the product. Record the information in the spaces provided below.

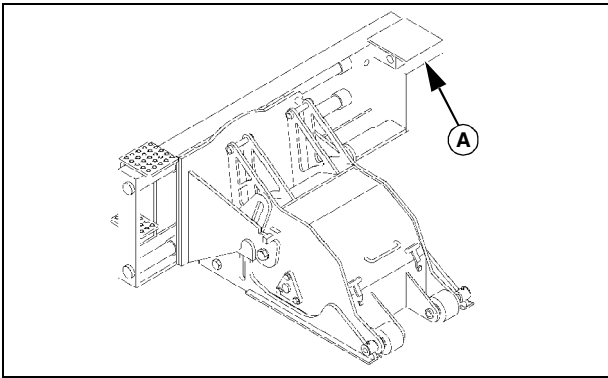

KV16949

DATE OF PURCHASE:

DEALER NAME:

DEALER PHONE:

SERIAL NUMBER (A):

TABLE OF CONTENTS

Safety	1
Preparing Vehicle	5
Installing	6
Removing	9
Operating	11
Operating - CP12.....	13
Operating - CP16, CP18, & CP24	15
Replacement Parts	17
Service Intervals	18
Service	19
Troubleshooting	22
Storage	23
Specifications	24
Warranty	25
Index.....	26

All information, illustrations and specifications in this manual are based on the latest information at the time of publication. The right is reserved to make changes at any time without notice.

COPYRIGHT© 2001
Deere & Co.
John Deere Worldwide Commercial and
Consumer Equipment Division
All rights reserved
Previous Editions
COPYRIGHT© 1999

OMKV16792 K1 - English

SAFETY

Understanding The Machine Safety Labels

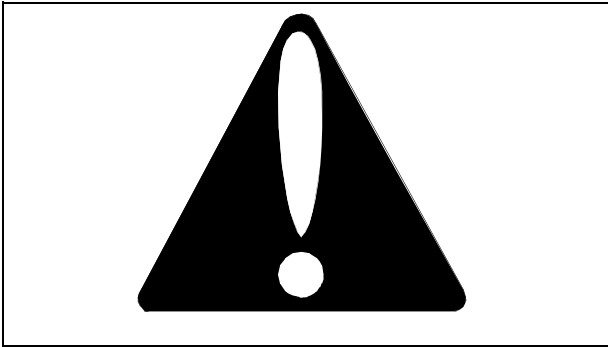

Safety-Alert Symbol

The machine safety labels shown in this section are placed in important areas on your machine to draw attention to potential safety hazards.

On your machine safety labels, the words DANGER, WARNING, and CAUTION are used with this safety-alert symbol. DANGER identifies the most serious hazards.

The operator's manual also explains any potential safety hazards whenever necessary in special safety messages that are identified with the word, CAUTION, and the safety-alert symbol.

WARNING - To Avoid Injury

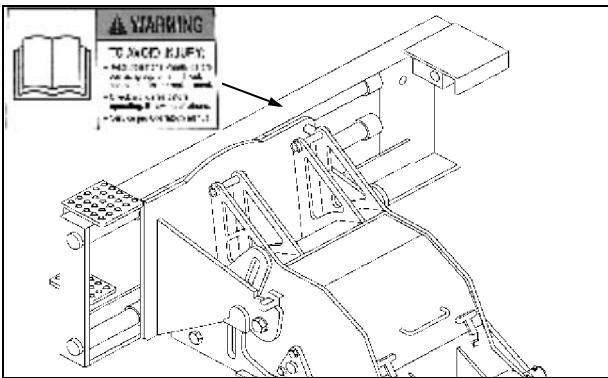

KV16949/ KV16591

- Read Operator's Manual before operating equipment. If lost, contact dealer for replacement.
- Check work area before operating. Be aware of others.
- Service per operator's manual.

WARNING - Rotating Cutter

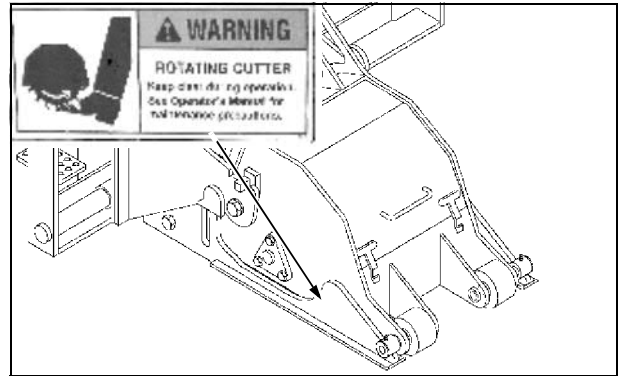

KV16949\ KV16967

- Keep clear during operation. See Operator's Manual for maintenance precautions.

WARNING - Flying Object Hazard

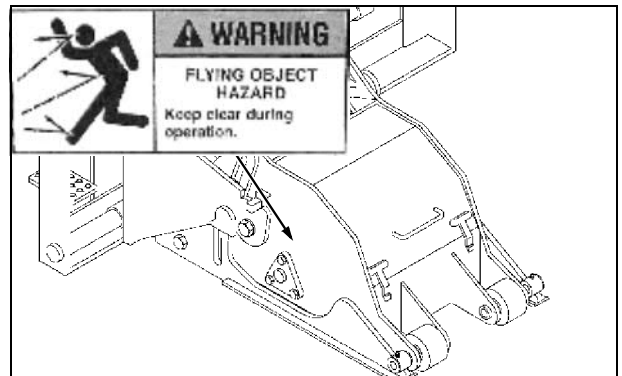

KV16949\ KV16957

- Keep clear during operation.

Danger - Pinch Area

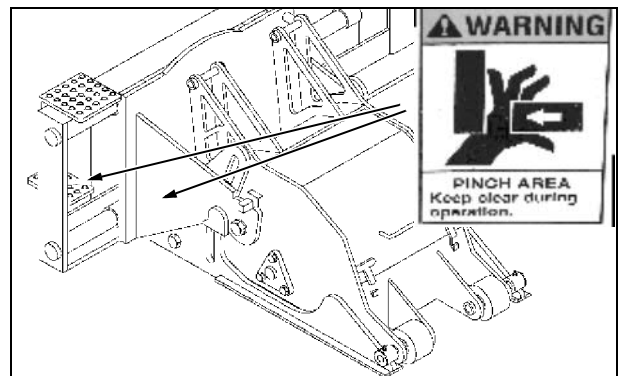

KV16949

- Keep clear during operation.

SAFETY

CAUTION - Not a Step

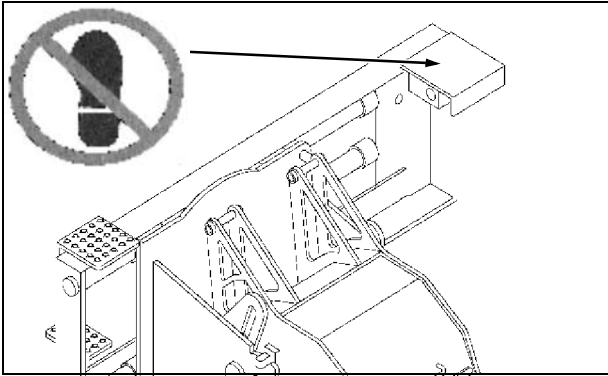

- Do not step on bracket.

Operator Training Required

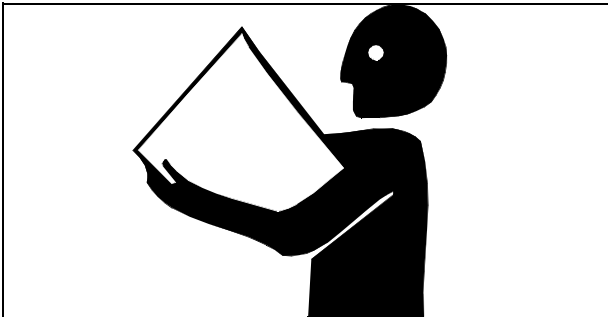

- Study the Skid Steer's Operator Manual. Know the location and function of all controls. Know how to operate the skid steer before using this attachment.
- Study operating section of this manual before operating a broom attachment. Know location and function of all controls.
- Operate machine in an open, unobstructed area under the direction of an experienced operator.
- Eye protection should be worn when operating the cold planer without a demolition door or cab enclosure.
- Operator experience is required to learn the moving, stopping, turning, and other operating characteristics of the machine.
- Learn the use of all controls.

Operate Safely

- Inspect the machine and attachment before you operate. Be sure all hardware is tight. Repair or replace damaged, badly worn, or missing parts. Be sure guards

and shields are in good condition and fastened in place. Make any necessary adjustments before you operate.

- Clear work area of objects that might be thrown. Keep people and pets out of the work area. Stop machine if anyone enters the area.
- Do not operate cold planer unless it is properly installed on the skid steer.
- If you hit an object, stop the machine and inspect machine for damage. Make repairs before you operate again. Keep machine properly maintained and in good working order.
- Do not leave machine unattended while it is running.
- Operate only during daylight or with adequate artificial light.
- Watch for overhead wires. Never touch wires with any part of the skid steer boom or attachment.
- Do not let anyone ride on the skid steer.
- Do not let children or an untrained person operate machine.
- Always check to the sides and rear of the skid steer before backing up.

Park Safely

1. Stop machine on a level surface, not on a slope.
2. Lower boom so attachment is on the ground. (If you must leave boom raised, be sure any attachment is removed and the boom locks are in the locked [Engaged] position, and boom is resting on locks.)
3. Engage park brake switch.
4. Stop engine and release seat belt.
5. Remove key.
6. Before you leave the operator's seat, wait for engine and all moving parts to stop.

Avoid Tipping

- Do not drive where machine could slip or tip.
- Stay alert for holes and other hidden hazards in the terrain. Avoid rocks, roots and ditches.
- Slow down before you make a sharp turn or operate on a slope.
- Drive up and down a hill - not across. Be careful when you change direction on a slope.
- If skid steer begins tipping forward with boom raised, immediately lower boom to regain stability.

SAFETY

Wear Appropriate Clothing

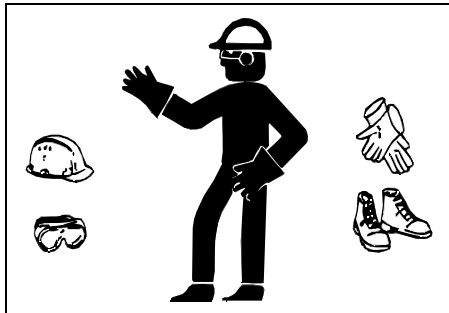

MIF

- Wear close fitting clothing and safety equipment appropriate for the job.
- Always wear safety goggles or safety glasses with side shields when operating the machine.
- Wear a suitable protective device such as earplugs. Loud noise can cause impairment or loss of hearing.
- Do not wear radio or music headphones. Safe service and operation requires your full attention.

Stay Clear of Rotating Devices



MIF

Entanglement in rotating devices can cause serious injury or death.

- Stop the engine and be sure attachment is stopped before exiting the skid steer and before allowing people near the attachment.

Practice Safe Maintenance

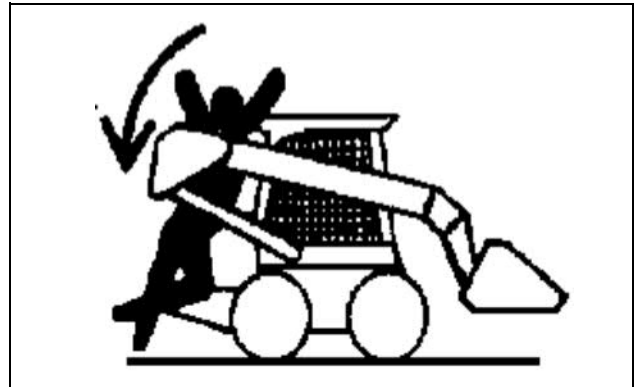

M71840A

- Do not work under a raised boom unless it is resting on boom locks and attachment has been removed. When lowered, boom arms will move near engine hood and frame; never stand or lean on skid steer where linkage can crush you.



MIF

- Understand service procedure before doing work. Keep area clean and dry.
- Never lubricate, service, or adjust machine while it is moving. Keep safety devices in place and in working condition. Keep hardware tight.
- Keep hands, feet, clothing, jewelry, and long hair away from any moving parts, to prevent them from getting caught.
- Lower attachment to the ground before servicing machine. Disengage all power and stop the engine. Engage park brake and remove the key. Let machine cool.
- Before servicing the machine, carefully release pressure from any components with stored energy, such as hydraulic components.
- Keep all nuts and bolts tightened.
- Securely support any machine elements that must be raised for service work.
- Never run engine unless park brake is locked.

Buy Now



Our support email:

ebooklibonline@outlook.com