

# UTILITY VEHICLE E-GATOR™

Serial No. (001001– )

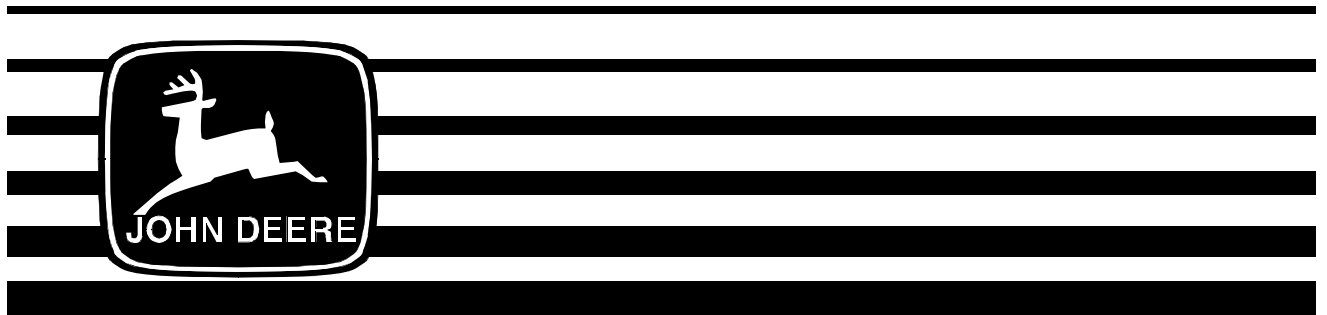

# OPERATOR'S MANUAL

John Deere  
Worldwide Commercial And  
Consumer Equipment Division  
OMM135735 E9

North American Version  
Litho in U.S.A.

English

# INTRODUCTION

---

**THANK YOU** for purchasing a John Deere product.

Read this manual thoroughly. Failure to do so could result in personal injury or equipment damage.

This manual should be considered a permanent part of your machine and should remain with the machine when you sell it.

Measurements in this manual are metric units and their U.S. customary equivalents. RIGHT-HAND and LEFT-HAND sides are determined by facing in the direction the machine will travel when going forward. When you see a broken line arrow (---->), it indicates the part it is pointing to is hidden.

Record identification numbers below. Be sure to record all the numbers to help in tracing the machine if it is stolen. You also need to give these numbers to your dealer when you order parts.

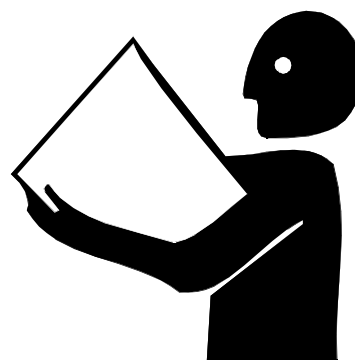

**DATE OF PURCHASE:**

\_\_\_\_\_

**DEALER NAME:**

\_\_\_\_\_

**DEALER PHONE:**

\_\_\_\_\_

**PRODUCT IDENTIFICATION NUMBER (A):**

-----

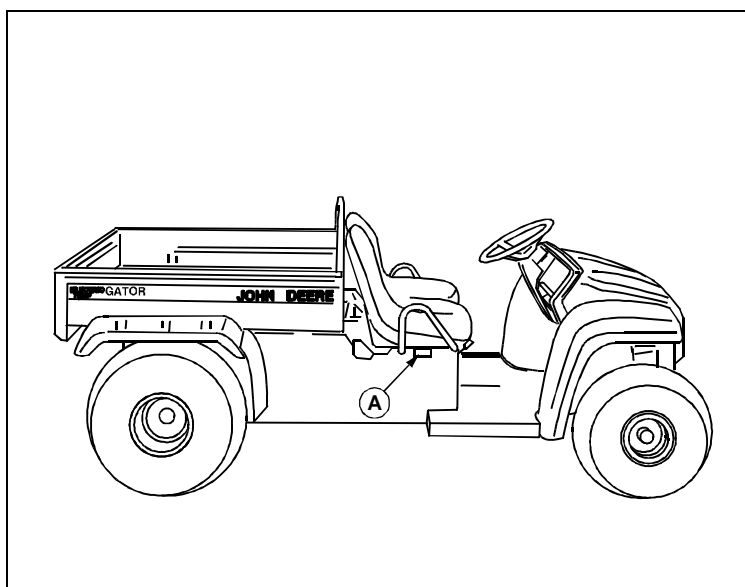

---

---

# TABLE OF CONTENTS

---

---

Safety Signs . . . . .	1
Controls . . . . .	7
Operating . . . . .	9
Replacement Parts . . . . .	43
Service Machine Safely . . . . .	44
Service Interval Chart . . . . .	50
Service -Battery . . . . .	52
Service -Electrical . . . . .	78
Service - Miscellaneous . . . . .	81
Troubleshooting . . . . .	86
Storing Machine . . . . .	88
Assembly . . . . .	92
Specifications . . . . .	104
Warranty . . . . .	114
Index . . . . .	115
John Deere Service Literature . . . . .	119

All information, illustrations and specifications in this manual are based on the latest information at the time of publication. The right is reserved to make changes at any time without notice.

COPYRIGHT© 1999  
Deere & Co.  
John Deere Worldwide Commercial and  
Consumer Equipment Division  
Horicon, WI  
All rights reserved

OMM135735 E9

# SAFETY SIGNS

## Safety-Alert Symbol

Read and recognize safety information. Be alert to the potential for personal injury when you see this safety-alert symbol.

On your machine safety labels, the words DANGER, WARNING, and CAUTION are used with this safety-alert symbol. DANGER identifies the most serious hazards. In this manual, the word CAUTION and this symbol call attention to safety messages.

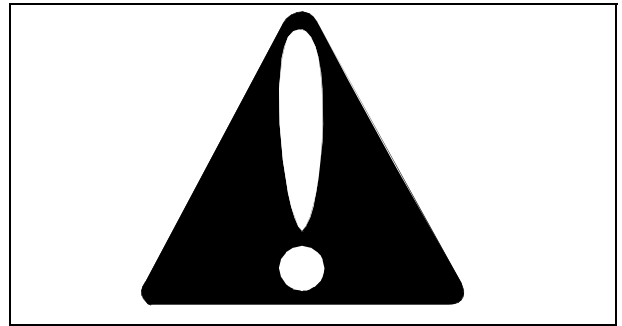

## Machine Safety Labels

### WARNING

#### RIDERS CAN FALL OFF AND BE KILLED

- Maximum of one person to a seat.
- No riders in box or anywhere else.

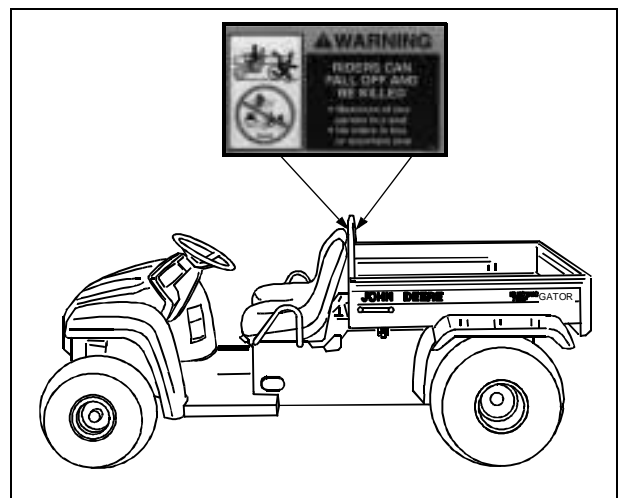

### DANGER

#### To avoid injury from electrical burns or battery explosion

- Read the operator's manual.
- Turn key off, place FORWARD/REVERSE lever to Neutral (N) and remove key.
- Place SERVICE switch in SERVICE position.
- Never disconnect a circuit under load at a battery terminal.
- Remove all jewelry (rings, watches etc.).
- Use insulated tools only.
- Disconnect batteries, as shown, to avoid unintentional starting of vehicle. Pay close attention to polarities when connecting batteries. Always connect the red end of the cable to the positive (+) post and the black end of the cable to the negative (-) post.

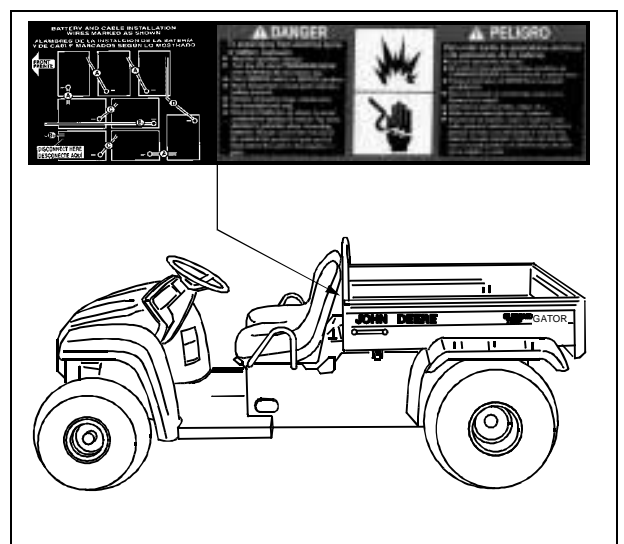

## SAFETY SIGNS

### WARNING

#### YOUNG DRIVERS INCREASE CHANCE OF DEATH

- Young drivers may not be able to control vehicle.
- No drivers younger than 16 years old.

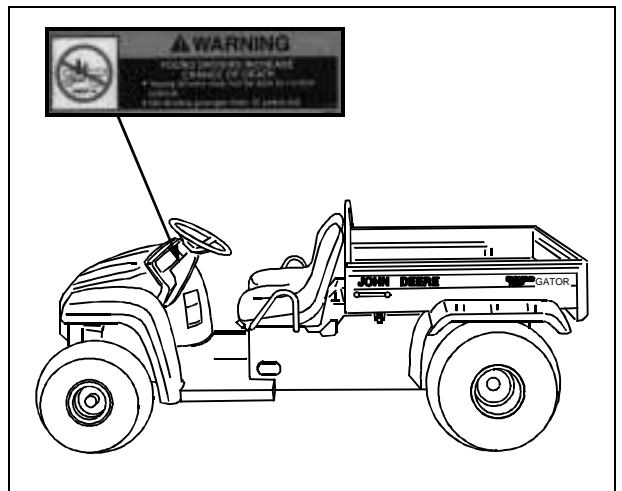

### WARNING

#### ROLLOVER OR FALLING OFF MAY CAUSE DEATH

- Read operator's manual.
- Drive very slowly when turning.
- Always use brakes going down a slope. Vehicle can take-off (freewheel) downhill.
- No loads heavier than 500 lbs (227 kg) in 4x2. Spread load evenly. Tie loads down.
- Reduce speed and load on rough or hilly ground.

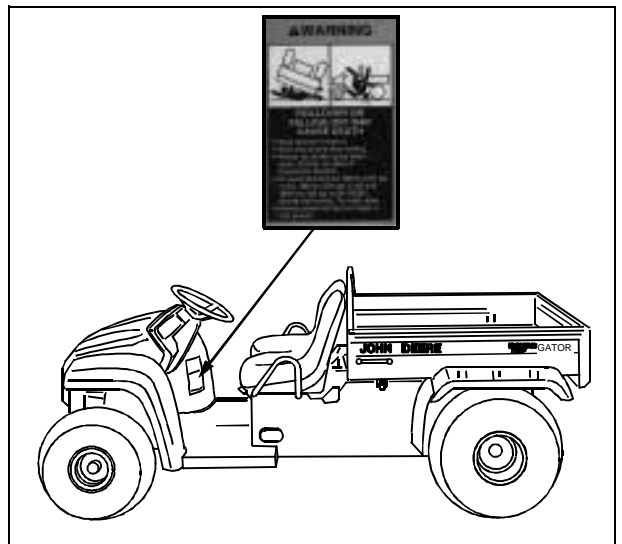

### CAUTION

#### Before leaving vehicle:

- Shift to neutral.
- Set park brake.
- Remove key.

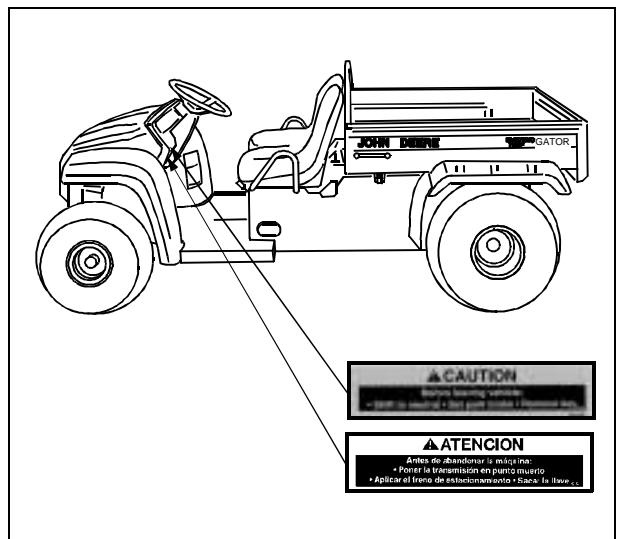

# SAFETY SIGNS

## DANGER/POISON

**Picture Note:** Raise cargo box to locate battery safety information. English DANGER/POISON information (A) molded into battery caps. Spanish DANGER/POISON labels (B) are located on each vehicle frame side rail.

## Explosive Gases

Cigarettes, flames or sparks could cause the batteries to explode. Always shield eyes and face from the batteries. Do not charge or use booster cables or adjust poor connections without proper instruction and training. Keep vent caps tight and level.

## Causes Severe Burns

Contains sulfuric acid. Avoid contact with skin, eyes or clothing. In event of an accident, flush with water and call a physician immediately. Keep out of reach of children.

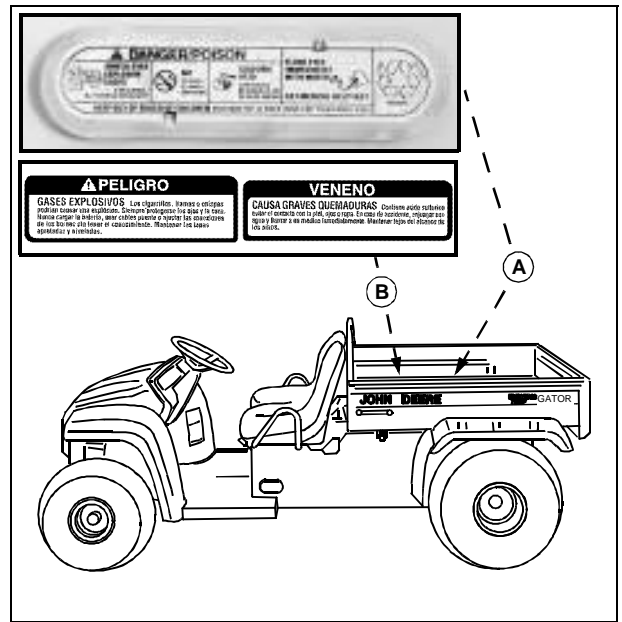

## DANGER

### To avoid injury from batteries and motor exploding or electrical arcing/shock:

**Picture Note:** Lift operator seat to locate safety labels.

Place switch in SERVICE position before servicing batteries or when towing.

Do not tow in excess of 15 m.p.h. (24 km/h) or motor may rupture or disintegrate.

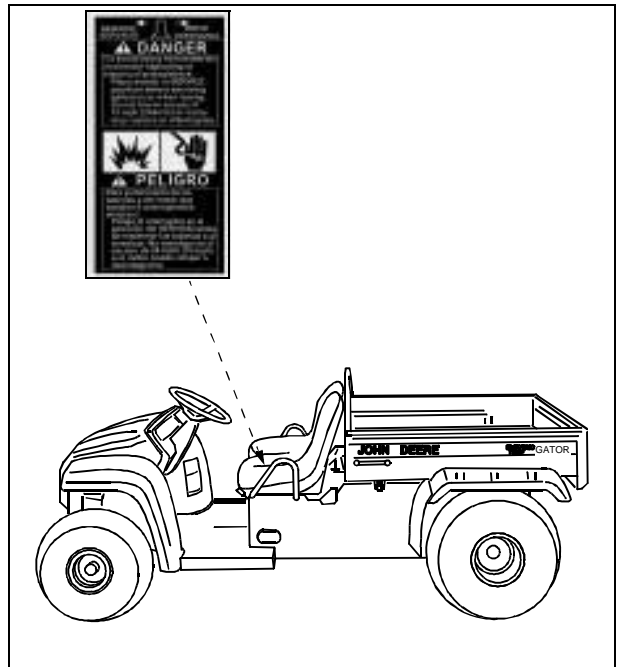

# SAFETY SIGNS

## CAUTION

### HELP PREVENT INJURY WHEN DUMPING LOADS

**Picture Note:** Safety label attached to cargo box load guard when equipped with the power lift option.

- Operate dump with machine stationary and parking brake locked: Never dump while moving.
- Operate dump on level ground only.
- Operate dump from operator's seat only.
- Do not place hands behind seat when lowering box.
- Refer to operator's manual for correct load distribution.

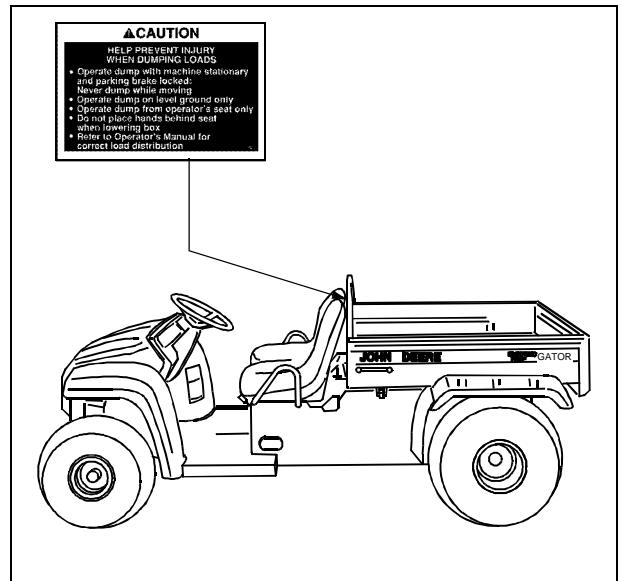

## Battery Charger Safety Labels

### CAUTION

Engage connector fully for proper charging.

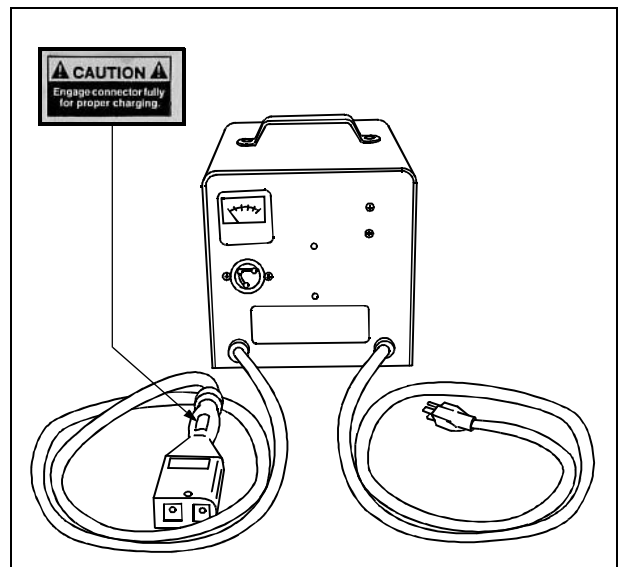

## SAFETY SIGNS

### WARNING

**Picture Note: Battery charger WARNING information inscribed on top of battery charger housing.**

- TO REDUCE THE RISK OF FIRE, DO NOT USE CHARGER NEAR FLAMMABLE MATERIALS OR VAPORS! BATTERIES GENERATE EXPLOSIVE GASSES DURING OPERATION. KEEP SPARKS AND FLAME AWAY FROM BATTERIES! NO SMOKING!
- MAKE SURE DC OUTPUT CHARGING PLUG AND RECEPTACLE ARE IN GOOD CONDITION! DO NOT USE IF DC PLUG OR RECEPTACLE ARE DAMAGED, LOOSE, OR FEEL HOTTER THAN NORMAL! REPLACE WORN OR DAMAGED PARTS IMMEDIATELY!
- DO NOT DISCONNECT THE CHARGER OUTPUT CONNECTOR FROM THE BATTERY CONNECTOR WHEN THE CHARGER IS ON. THE RESULTING ARCING AND BURNING WILL DAMAGE THE CONNECTORS AND COULD CAUSE THE BATTERIES TO EXPLODE. DISCONNECT INPUT CORD TO TURN CHARGER OFF.
- TO AVOID DAMAGE TO OUTPUT CORD, PLUG AND BATTERY RECEPTACLE, DO NOT PULL ON OUTPUT CORD! DO NOT TWIST, ROCK OR BEND PLUG SIDEWAYS!

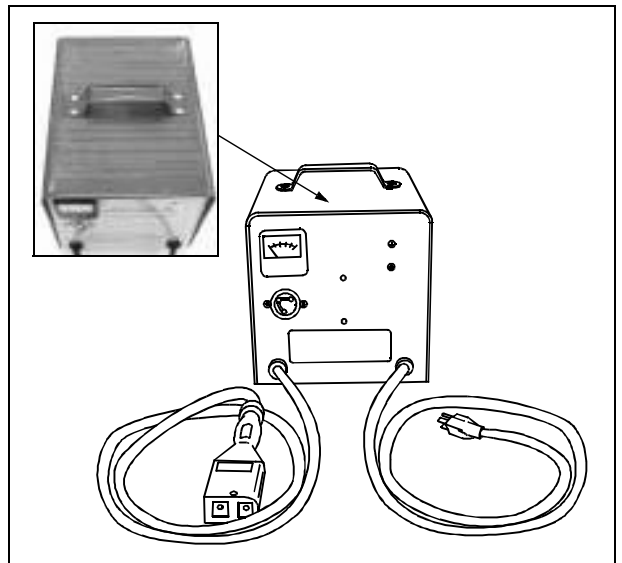

### DANGER

**Picture Note: Battery charger DANGER information inscribed on top of battery charger housing.**

- ELECTRICAL SHOCK HAZARD! DO NOT TOUCH UNINSULATED PORTION OF OUTPUT CONNECTOR OR UNINSULATED BATTERY TERMINALS!

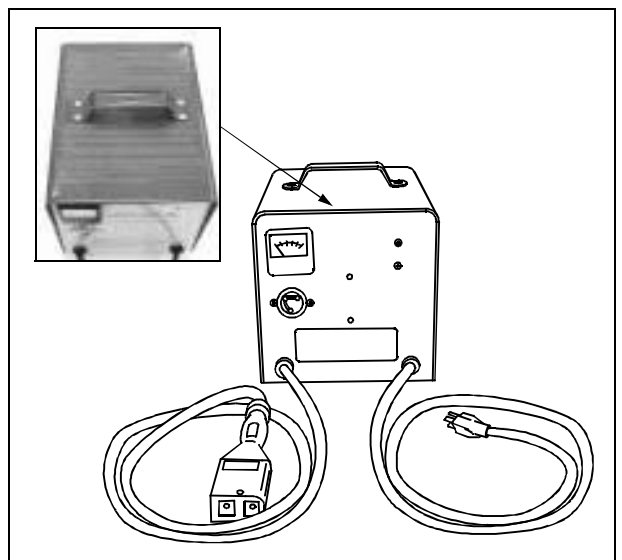



**Buy Now**



Our support email:

[ebooklibonline@outlook.com](mailto:ebooklibonline@outlook.com)