

# **47 and 59-Inch Snowblowers for 55 Series Tractors, 670 and 770 Tractors**

(Serial No. 010001 –     ) (55 Series Tractors)  
(Serial No. 100001 –     ) (670 and 770 Tractors)

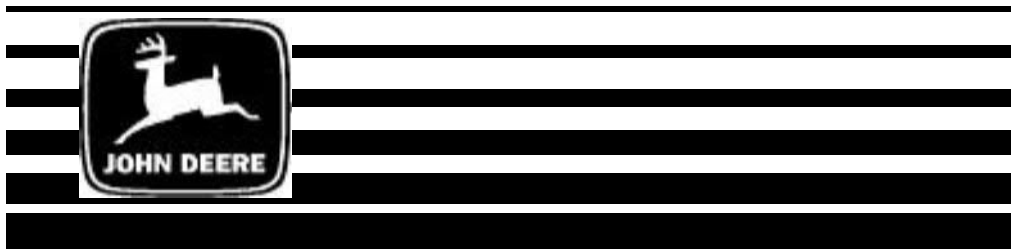

## **OPERATOR'S MANUAL**

**John Deere  
Lawn & Grounds Care Division  
OMM123336 C6**

North American Version  
Litho in U.S.A  
English

## INTRODUCTION

---

---

**THANK YOU** for purchasing a John Deere product.

The 47-Inch Snowblower can be used on the 55 Series Tractors. It will also fit the 670 and 770 Tractors but it will not cover the entire wheel track.



The 59-Inch Snowblower can be used on the 55 Series Tractors, and the 670, and 770 Tractors.

All information in this manual can be used for both snowblowers, and tractor models mentioned above. When information is for a specific application, it will be spelled out as such.

Read this manual and your vehicle manual thoroughly. Failure to do so could result in personal injury or equipment damage.

This manual should be considered a permanent part of your machine and should remain with the machine when you sell it.

Measurements in this manual are U.S. customary units and their metric equivalents. RIGHT-HAND and LEFT-HAND sides are determined by facing in the direction the machine will travel when going forward. When you see a broken line arrow ( - - - ➔ ) it indicates the part it is pointing to is hidden.

Product warranty is provided as part of John Deere's support program for customers who operate and maintain their equipment as described in this manual. The product warranty is explained on the warranty certificate you received from your dealer.

---

# INTRODUCTION

---

---

Record identification numbers below. Be sure to record all the numbers to help in tracing the machine if it is stolen. You also need to give these numbers to your dealer when you order parts.

<b>Date of Purchase:</b> _____
-----------------------------------

<b>Dealer Name:</b> _____	<b>Phone:</b> _____
------------------------------	------------------------

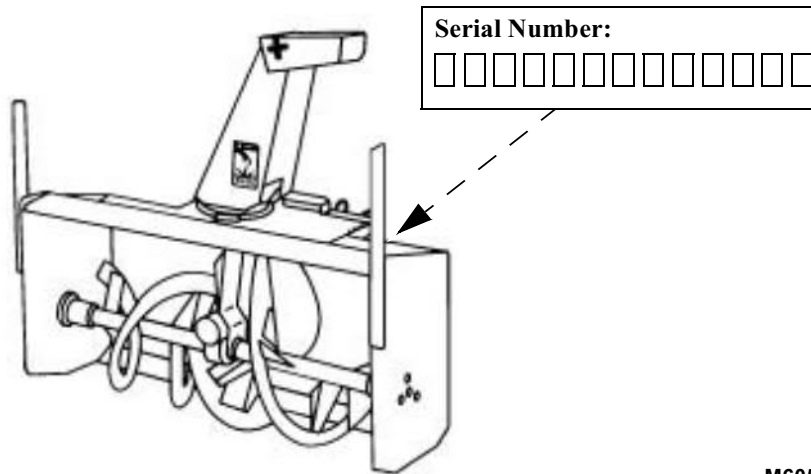

M60517

---

# TABLE OF CONTENTS

---

	Page
<b>Safety Signs</b>	
Safety-Alert Symbol .....	1
Machine Safety Labels.....	1
<b>Preparing the Tractor</b>	
Preparing the Tractor .....	3
<b>Installing</b>	
Park Vehicle Safely .....	4
Avoid High Pressure Fluids.....	4
Install Snowblower .....	5
<b>Removing</b>	
Park Vehicle Safely .....	8
Avoid High Pressure Fluids.....	8
Removing Snowblower. ....	9
<b>Operating</b>	
SAFETY:	
Operate Safely .....	11
Wear Appropriate Clothing.....	11
Stay Clear of Rotating Drivelines .....	12
Avoid Injury from Moving Parts .....	12
Avoid Injury from Hitting Obstructions.....	12
OPERATION:	
Adjusting Spout.....	13
Adjusting Height of Scraper Blade .....	13
Raising and Lowering Snowblower .....	15
Turning Chute .....	15
Starting Snowblower .....	16
Stopping Snowblower .....	17
Snowblowing Tips .....	18
Transporting Tractor and Snowblower.....	18

---

## TABLE OF CONTENTS

---

	Page
<b>Service Machine Safely</b>	
Practice Safe Maintenance .....	19
Wear Appropriate Clothing .....	20
Stay Clear of Rotating Drivelines.....	20
Avoid Injury from Moving Parts.....	20
Avoid High Pressure Fluids .....	21
<b>Service</b>	
Service Intervals .....	22
Grease .....	23
Gear Oil .....	24
Lubricating Worm Gear Shaft .....	24
Lubricating Driveline .....	25
Lubricating Auger Shaft .....	25
Service Snowblower Safely .....	26
Checking Auger Gearbox Oil Level .....	26
Checking Snowblower Gearbox Oil Level .....	27
Replacing Shear Bolts .....	27
Replacing Discharge Chute Cables.....	28
Routing Chute Cables.....	29
Installing Cable Shield .....	30
Reversing or Replacing Scraper Blade.....	31
<b>Troubleshooting</b>	
Using Troubleshooting Chart .....	32
<b>Storing Machine</b>	
Storing Snowblower.....	33

## TABLE OF CONTENTS

---

---

	Page
<b>Assembly</b>	
Install Driveshaft.....	34
Install Lift Arms.....	34
Install Chute .....	35
Route Chute Cables.....	35
Install Cable Shield .....	37
Install Drift Blade .....	37
Install Wear Plate (Optional).....	38
<b>Specifications</b>	
Snowblower Specifications .....	39
Recommended Lubricants .....	40
<b>John Deere Service Literature</b>	
Order Form.....	43

All information, illustrations and specifications in this manual are based on the latest information at the time of publication. The right is reserved to make changes at any time without notice.

COPYRIGHT© 1996  
John Deere Horicon Works  
All rights reserved  
Previous Editions  
COPYRIGHT© 1995, 1994, 1990,  
1988 and 1986

# SAFETY SIGNS

## Safety-Alert Symbol

Read and recognize safety information. Be alert to the potential for personal injury when you see this safety-alert symbol.

On your machine safety labels, the words DANGER, WARNING, and CAUTION are used with this safety-alert symbol. DANGER identifies the most serious hazards. In this manual, the word CAUTION and this symbol call attention to safety messages.



## Machine Safety Labels

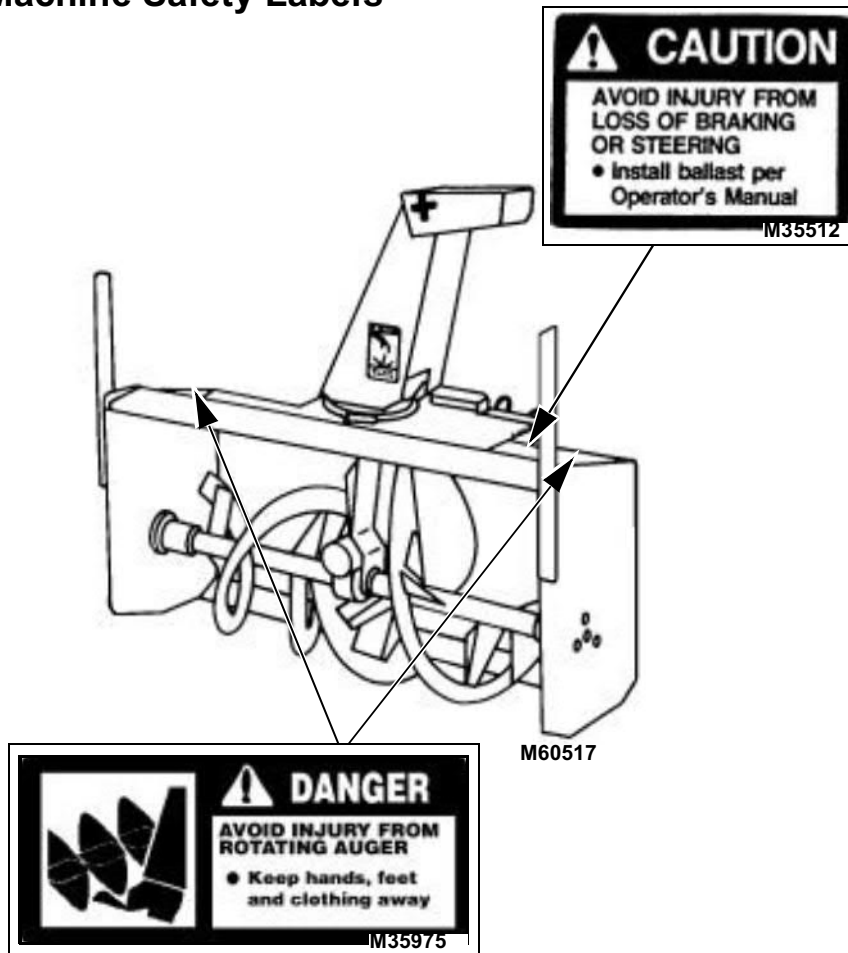

**Buy Now**



Our support email:

[ebooklibonline@outlook.com](mailto:ebooklibonline@outlook.com)