

47, 48, and 49 Backhoe for 4200—4700, 5105 and 5205, 5200—5500, 5210—5510 Tractors

OPERATOR'S MANUAL 47, 48 and 49 Backhoe OMM135891 E1 (ENGLISH)

CALIFORNIA
Proposition 65 Warning

Diesel engine exhaust and some of its constituents are known to the State of California to cause cancer, birth defects, and other reproductive harm.

If this product contains a gasoline engine:

 **WARNING**

The engine exhaust from this product contains chemicals known to the State of California to cause cancer, birth defects or other reproductive harm.

The State of California requires the above two warnings.

John Deere Augusta Works
LITHO IN U.S.A.

Introduction

Foreword

READ THIS MANUAL carefully to learn how to operate and service your machine correctly. Failure to do so could result in personal injury or equipment damage. This manual and safety signs on your machine may also be available in other languages. (See your John Deere dealer to order.)

THIS MANUAL SHOULD BE CONSIDERED a permanent part of your machine and should remain with the machine when you sell it.

MEASUREMENTS in this manual are given in both metric and customary U.S. unit equivalents. Use only correct replacement parts and fasteners. Metric and inch fasteners may require a specific metric or inch wrench.

RIGHT-HAND AND LEFT-HAND sides are determined by facing in the direction of forward travel.

WRITE PRODUCT IDENTIFICATION NUMBERS (P.I.N.) in the Specification or Identification Numbers section. Accurately record all the numbers to help in tracing the machine should it be stolen. Your dealer also needs these numbers when you order parts. File the identification numbers in a secure place off the machine.

WARRANTY is provided as part of John Deere's support program for customers who operate and maintain their equipment as described in this manual. The warranty is explained on the warranty certificate which you should have received from your dealer.

This warranty provides you the assurance that John Deere will back its products where defects appear within the warranty period. In some circumstances, John Deere also provides field improvements, often without charge to the customer, even if the product is out of warranty. Should the equipment be abused, or modified to change its performance beyond the original factory specifications, the warranty will become void and field improvements may be denied. Setting fuel delivery above specifications or otherwise overpowering machines will result in such action.

THE TIRE MANUFACTURER'S warranty supplied with your machine may not apply outside the U.S.

CALIFORNIA PROPOSITION 65 WARNING: Diesel engine exhaust and some of its constituents are known to the State of California to cause cancer, birth defects, and other reproductive harm.

DX,IFC1 -19-19SEP00-1/1

Identification Numbers

Record identification numbers. Be sure to record all the numbers to help in tracing the machine if it is

stolen. You also need to give these numbers to your dealer when you order parts.

OUC1085,0000292 -19-15NOV00-1/2

Introduction

DATE OF PURCHASE:

DEALER NAME:

DEALER PHONE:

SERIAL NUMBER (A):

A—Serial Number

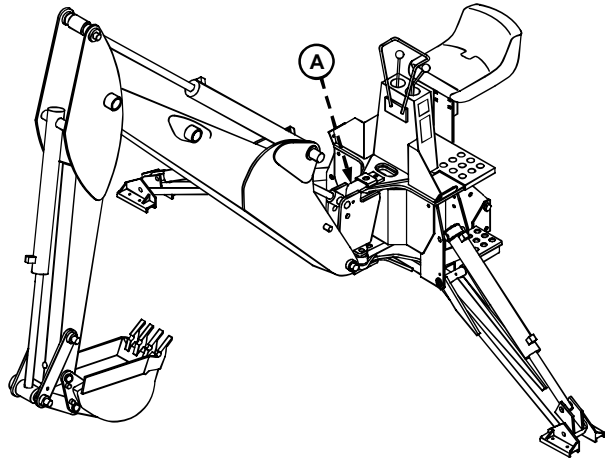

LV5660 -UN-18SEP01

OUO1085,0000292 -19-15NOV00-2/2

Contents

	Page		Page
Safety	05-1	Installing Rear Hanger (5105, 5205 Tractors)	25-36
Safety Signs	10-1	Aligning Frame (5105, 5205 Tractors)	25-38
Controls		Preparing Tractor Hydraulics (5105, 5205 Tractors)	25-39
Controls	15-1	Disassembling Shipping Pallet (5105, 5205 Tractors)	25-48
Assembly—47 Backhoe		Installing Subframe to Mainframe (5105, 5205 Tractors)	25-50
Preparing Tractor	20-1	Preparing Backhoe Hydraulics (5105, 5205 Tractors)	25-51
Installing Rockshaft Attachment (RSA) Mounting Plate	20-2	Installing Stabilizers and Stabilizer Cylinders ..	25-53
Removing 47 Backhoe from Pallet	20-5	Installing Operator's Seat	25-55
Assembling 47 Backhoe	20-6	Installing Bucket	25-56
Attaching Backhoe to Tractor	20-9	Installing Optional Street Pad Kit	25-57
Avoid High-Pressure Fluids	20-11		
Connecting Hydraulic Hoses	20-11	Assembly—49 Backhoe	
Installing Stabilizers and Stabilizer Cylinders ..	20-12	Removing 3-Point Hitch	30-1
Installing Bucket	20-13	Installing Front Hanger	30-2
Installing Optional Street Pad Kit	20-15	Installing Rear Hanger	30-4
Assembly—48 Backhoe		Aligning Frame	30-6
Preparing Tractor (4300, 4400 Tractors)	25-1	Avoid High-Pressure Fluids	30-7
Installing Rockshaft Attachment (RSA) Mounting Plate (4300, 4400 Tractors)	25-2	Preparing Tractor Hydraulics	30-7
Preparing Tractor (4500—4700 Tractors)	25-5	Disassembling Shipping Pallet	30-9
Installing Rockshaft Attachment (RSA) Mounting Plate (4500—4700 Tractors)	25-6	Installing Stabilizers and Stabilizer Cylinders ..	30-10
Disassembling Shipping Pallet (4300—4700 Tractors)	25-22	Installing Subframe to Mainframe	30-11
Assembling 48 Backhoe (4300—4700 Tractors)	25-24	Preparing Backhoe Hydraulics	30-11
Routing Hydraulic Hoses (4300—4700 Tractors)	25-29	Installing Bucket	30-13
Attaching Backhoe to Tractor (4300—4700 Tractors)	25-31	Installing Optional Street Pad Kit	30-14
Avoid High-Pressure Fluids	25-33		
Connecting Hydraulic Hoses (4300—4700 Tractors)	25-33	Attaching and Detaching—47 Backhoe	
Removing 3-Point Hitch (5105, 5205 Tractors)	25-35	Park Tractor Safely	35-1
Installing Front Hanger (5105, 5205 Tractors)	25-35	Preparing Backhoe for Attachment	35-2
		Attaching Backhoe	35-3
		Avoid High-Pressure Fluids	35-4
		Connecting Hydraulic Hoses	35-5
		Installing and Removing Slow Moving Vehicle (SMV) Sign	35-6
		Preparing Backhoe for Detachment	35-7
		Disconnecting Hydraulic Hoses	35-8
		Detaching Backhoe	35-9

Continued on next page

All information, illustrations and specifications in this manual are based on the latest information available at the time of publication. The right is reserved to make changes at any time without notice.

COPYRIGHT © 2000
DEERE & COMPANY
Moline, Illinois
All rights reserved
A John Deere ILLUSTRATION® Manual

Contents

	Page		Page
Attaching and Detaching—48 Backhoe			
Park Tractor Safely	40-1	Lifting with Backhoe	50-10
Preparing Backhoe for Attachment (4300— 4700 Tractors)	40-2	Transporting Backhoe	50-11
Attaching Backhoe (4300—4700 Tractors)	40-3	Service Machine Safely	
Avoid High-Pressure Fluids	40-4	Practice Safe Maintenance	55-1
Connecting Hydraulic Hose (4300—4700 Tractors)	40-5	Handle Chemical Products Safely	55-2
Installing and Removing Slow Moving Vehicle (SMV) Sign (4300 and 4400 tractors)	40-8	Wear Protective Clothing	55-2
Preparing Backhoe for Detachment (4300— 4700 Tractors)	40-9	Stay Clear of Rotating Drivelines	55-3
Disconnecting Hydraulic Hoses (4300— 4700 Tractors)	40-10	Avoid Heating Near Pressurized Fluid Lines	55-3
Detaching Backhoe (4300—4700 Tractors)	40-12	Avoid High-Pressure Fluids	55-4
Park Tractor Safely (5105, 5205 Tractors)	40-13	Service	
Avoid High-Pressure Fluids	40-14	Service Intervals	60-1
Connecting Hydraulic Hoses (5105, 5205 Tractors)	40-15	Help Prevent Injury During Service	60-1
Attaching and Detaching Backhoe (5105, 5205 Tractors)	40-16	Replacing Bucket Teeth	60-2
Installing and Removing Slow Moving Vehicle (SMV) Sign (5105, 5205 Tractors)	40-19	Checking Tractor Hydraulic Fluid Level	60-2
Avoid High-Pressure Fluids	40-20	Cleaning Inside Valve Covers	60-4
Disconnecting Hydraulic Hoses (5105, 5205 Tractors)	40-21	Grease	60-5
Attaching and Detaching—49 Backhoe		Lubrication Safety	60-6
Park Tractor Safely	45-1	Lubricating Boom and Stabilizers	60-7
Avoid High-Pressure Fluids	45-2	Lubricating Bucket and Link Linkage	60-7
Connecting Hydraulic Hoses	45-3	Lubricating Boom, Dipperstick Cylinders, and Dipperstick Pivot	60-8
Attaching and Detaching Backhoe	45-4	Troubleshooting	
Installing and Removing Slow Moving Vehicle (SMV) Sign	45-7	Using Troubleshooting Chart	65-1
Avoid High-Pressure Fluids	45-8	Storing Machine	
Disconnecting Hydraulic Hoses	45-9	Storing Machine Safely	70-1
Operating Machine		Specifications	
Operate Safely	50-1	Dimensions	70-1
Wear Protective Clothing	50-1	Backhoe Compatibility	70-8
Backhoe Safety Tips	50-2	John Deere Service Keeps You on the Job	
Adjusting Operator's Seat	50-2	John Deere Quality	IBC-1
Using Controls	50-4		
Digging Safely	50-5		
Slow Moving Vehicle (SMV) Sign	50-5		
Operating Tractor	50-6		
Removing Boom and Swing Lock Pins	50-7		
Digging Position	50-8		
Digging Angle	50-8		
Bucket Digging	50-8		
Dipperstick Digging	50-9		
Spoil Pile Location	50-9		

Safety

Recognize Safety Information

This is a safety-alert symbol. When you see this symbol on your machine or in this manual, be alert to the potential for personal injury.

Follow recommended precautions and safe operating practices.

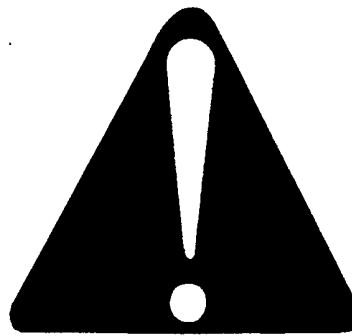

DX,ALERT -19-29SEP98-1/1

TS1389 -UN-07DEC88

Understand Signal Words

A signal word—DANGER, WARNING, or CAUTION—is used with the safety-alert symbol. DANGER identifies the most serious hazards.

DANGER or WARNING safety signs are located near specific hazards. General precautions are listed on CAUTION safety signs. CAUTION also calls attention to safety messages in this manual.



DX,SIGNAL -19-03MAR93-1/1

TS187 -19-30SEP88

Follow Safety Instructions

Carefully read all safety messages in this manual and on your machine safety signs. Keep safety signs in good condition. Replace missing or damaged safety signs. Be sure new equipment components and repair parts include the current safety signs. Replacement safety signs are available from your John Deere dealer.

Learn how to operate the machine and how to use controls properly. Do not let anyone operate without instruction.

Keep your machine in proper working condition. Unauthorized modifications to the machine may impair the function and/or safety and affect machine life.

If you do not understand any part of this manual and need assistance, contact your John Deere dealer.



DX,READ -19-03MAR93-1/1

TS201 -UN-23AUG88

Prevent Machine Runaway

Avoid possible injury or death from machinery runaway.

Do not start engine by shorting across starter terminals. Machine will start in gear if normal circuitry is bypassed.

NEVER start engine while standing on ground. Start engine only from operator's seat, with transmission in neutral or park.



TS177 -UN-11JAN89

DX.BYPAS1 -19-29SEP98-1/1

Operate Tractor Safely

Features designed into your tractor make operation safer and let it perform a wide variety of jobs. Use your tractor only for specified jobs it was designed to perform: implement carrier, load mover, remote power source, or transport unit—not a recreational vehicle.

Careless use or misuse can result in unnecessary accidents. Be alert to hazards of tractor operation. Understand causes of accidents and take every precaution to avoid them. Most common accidents are caused from:

- Tractor upsets
- Improper starting procedures
- Crushing and pinching during hitching
- Collisions with other motor vehicles
- Getting entangled in PTO shafts
- Falls from tractors

Avoid accidents by taking the following precautions:

Put transmission in PARK before dismounting. Leaving transmission in gear with engine stopped will NOT prevent the tractor from moving.

Be sure everyone is clear of tractor and attached equipment before starting engine.

Never try to get on or off a moving tractor.

When tractor is left unattended, place in PARK, lower implements to the ground, stop the engine, and remove the key.



TS276 -UN-23AUG88

LV_5010SA,A -19-06JUN97-1/1

Use Caution on Hillsides

Always wear seat belt with ROPS in upper position.

Avoid holes, ditches, and obstructions which cause the tractor to tip, especially on hillsides. Avoid sharp, uphill turns.

Never drive near the edge of a gully or steep embankment -- it might cave in.

Driving forward out of a ditch or mired condition or up a steep slope could cause tractor to tip over rearward. Back out of these situations if possible.

While mechanical front wheel drive greatly increases traction, it DOES NOT increase stability of the tractor. With mechanical front wheel drive engaged, the tractor can climb steeper slopes but it does not become more stable. When this option is used, extra caution is needed on slopes. Compared to a 2-wheel drive, a front-wheel drive tractor maintains traction on steeper slopes, increasing the possibility of a tip over.

Danger of overturn increases greatly with narrow tread setting, at high speed.

Hitch towed loads only to drawbar. When using a chain, take up the slack slowly.

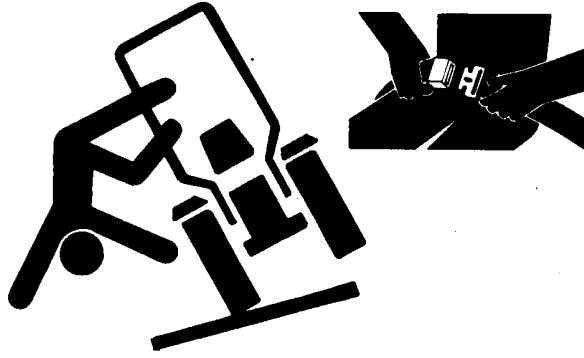

T5205 -JN-23AUG88

MX,SAIP,CA1 -19-29JUL94-1/1

Drive Machine Safely

Set boom lock and swing lock pins to center backhoe before driving. If you must drive on steep hillsides, move the backhoe to uphill side for added stability.

Drive carefully:

- on slopes
- where room is limited
- over rough ground, curbs, or tracks
- near a ditch or excavation

For traveling:

- be sure brake pedals are connected
- lower loader bucket
- keep machine in gear at all times

Use accessory lights and safety devices to warn operators of other vehicles.

Where flashing lights are prohibited, disconnect warning light flasher.

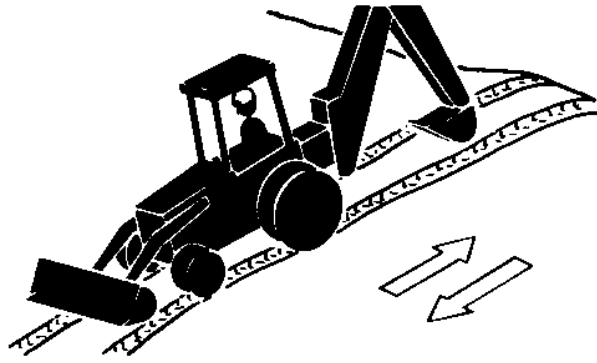

T7208AC -JN-19FEB90

TX,05,DB2035 -19-07OCT96-1/1

Avoid Tipping

Always wear seat belt with ROPS in upper position.

Do not drive where machine could slip or tip.

Stay alert for holes, rocks, and roots in the terrain, and other hidden hazards. Keep away from drop-offs.

Slow down before you make a sharp turn.

Use care when pulling loads or using heavy equipment:

- Use only approved drawbar hitch points.
- Limit loads to those you can safely control.
- Use counterweights or wheel weights when suggested in this operator's manual.

Reduce speed and exercise extreme caution on slopes and in sharp turns to prevent tipping or loss of control. Be especially cautious when changing direction on slopes.

Do not stop or start suddenly when going uphill or downhill.

If machine stops going up hill:

- STOP the PTO.
- Back down slowly.

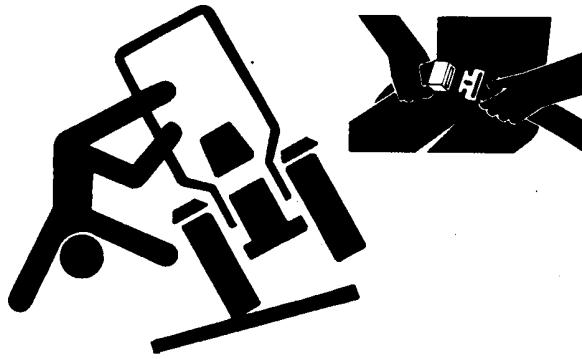

TS205 -JN-23AUG88

MX,AVOIDTIP1A1 -19-22JUL94-1/1

Freeing a Mired Machine

Attempting to free a mired machine can involve safety hazards such as the mired tractor tipping rearward, the towing tractor overturning, and the tow chain or tow bar (a cable is not recommended) failing and recoiling from its stretched condition.

Back your tractor out if it gets mired down in mud. Unhitch any towed implements. Dig mud from behind the rear wheels. Place boards behind the wheels to provide a solid base and try to back out slowly. If necessary, dig mud from the front of all wheels and drive slowly ahead.

If necessary to tow with another unit, use a tow bar or a long chain (a cable is not recommended). Inspect the chain for flaws. Make sure all parts of towing devices are of adequate size and strong enough to handle the load.

Always hitch to the drawbar of the towing unit. Do not hitch to the front pushbar attachment point. Before moving, clear the area of people. Apply power smoothly to take up the slack: a sudden pull could snap any towing device causing it to whip or recoil dangerously.

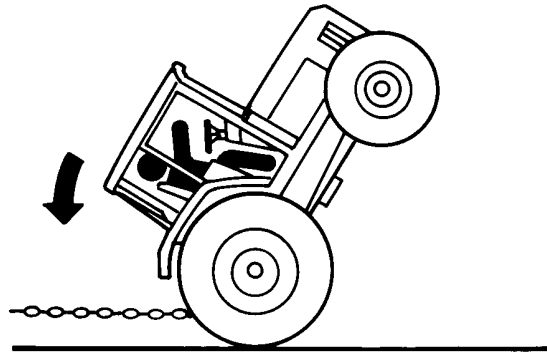

TS1645 -UN-15SEP95



TS263 -UN-23AUG88

DX,MIREO -19-07JUL99-1/1

Work In Ventilated Area

Engine exhaust fumes can cause sickness or death. If it is necessary to run an engine in an enclosed area, remove the exhaust fumes from the area with an exhaust pipe extension.

If you do not have an exhaust pipe extension, open the doors and get outside air into the area.

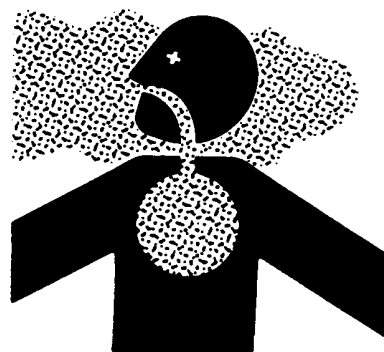

TS220 -UN-23AUG88

DX,AIR -19-17FEB99-1/1

Park Tractor Safely

To park tractor safely:

- Disengage PTO.
- Lower equipment to the ground.
- Put gear shift lever in PARK.
- STOP the engine.
- Remove key.

Before you leave the operator's seat, wait for engine and attachment parts to stop moving.

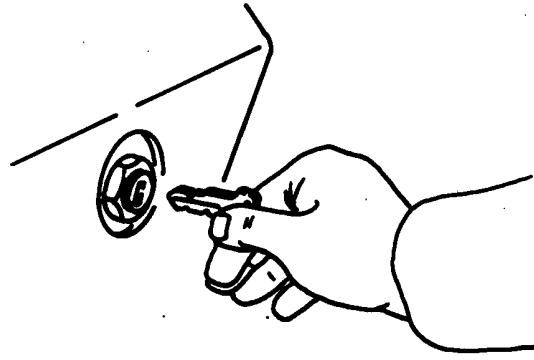

M35691 -UN-26APR89

MX,SAIP,AAA1 -19-29JUL94-1/1

Keep Riders Off Machine

Only allow the operator on the machine. Keep riders off.

Riders on machine are subject to injury such as being struck by foreign objects and being thrown off of the machine. Riders also obstruct the operator's view resulting in the machine being operated in an unsafe manner.

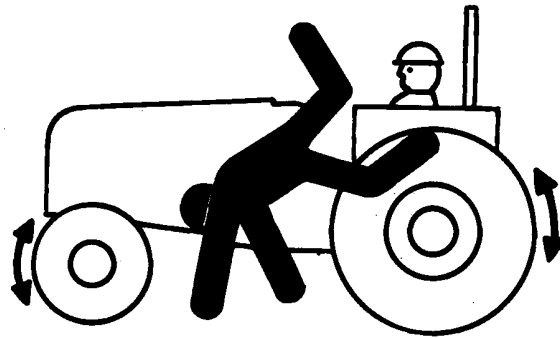

TS290 -UN-23AUG88

DX,RIDER -19-03MAR93-1/1

Handle Fuel Safely—Avoid Fires

Handle fuel with care; it is highly flammable. Do not refuel the machine while smoking or when near open flame or sparks.

Always stop engine before refueling machine. Fill fuel tank outdoors.

Prevent fires by keeping machine clean of accumulated trash, grease, and debris. Always clean up spilled fuel.



TS202 -UN-23AUG88

DX,FIRE1 -19-03MAR93-1/1

Prepare for Emergencies

Be prepared if a fire starts.

Keep a first aid kit and fire extinguisher handy.

Keep emergency numbers for doctors, ambulance service, hospital, and fire department near your telephone.

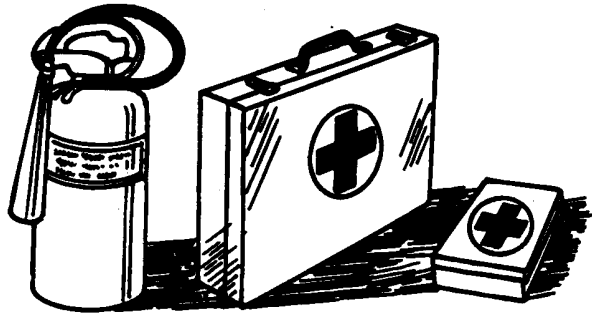

TS291 -UN-23AUG88

DX,FIRE2 -19-03MAR93-1/1

Do Not Use Starting Fluid

DO NOT use starting fluid in tractors equipped with an intake air heater system. (See your John Deere dealer for a complete list of other starting aids available).

Tractors are equipped with an intake air heater system.



LV611 -UN-22APR94

MX,SAIP,JA2 -19-24JUL95-1/1

Wear Protective Clothing

Wear close fitting clothing and safety equipment appropriate to the job.

Prolonged exposure to loud noise can cause impairment or loss of hearing.

Wear a suitable hearing protective device such as earmuffs or earplugs to protect against objectionable or uncomfortable loud noises.

Operating equipment safely requires the full attention of the operator. Do not wear radio or music headphones while operating machine.

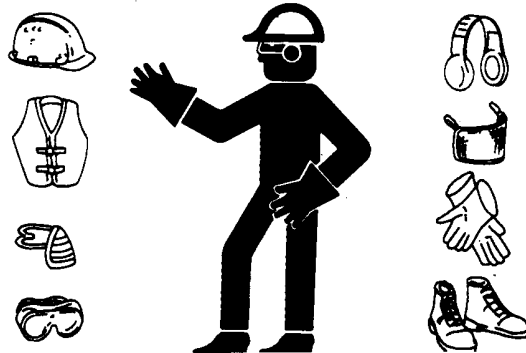

TS206 -UN-23AUG88

DX,WEAR -19-10SEP90-1/1

Buy Now



Our support email:

ebooklibonline@outlook.com