

# **PTO TILLER for 4300-4600 Compact Utility Tractors Models 660, 670 and 680**

Serial No. (010001 - )

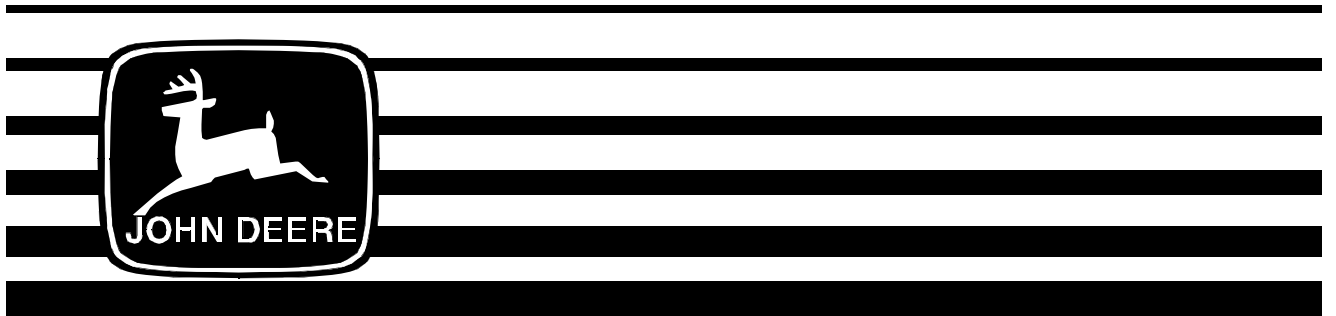

## **OPERATOR'S MANUAL**

**John Deere  
Worldwide Commercial And  
Consumer Equipment Division  
OMM137899 G8**

North American Version  
Litho in U.S.A.  
English

# INTRODUCTION

## THANK YOU for purchasing a John Deere product.

Read this manual and your vehicle manual thoroughly. Failure to do so could result in personal injury or equipment damage.

This manual should be considered a permanent part of your machine and should remain with the machine when you sell it.

Measurements in this manual are metric units and their U.S. customary equivalents. RIGHT-HAND and LEFT-HAND sides are determined by facing in the direction the machine will travel when going forward. When you see a broken line arrow (---->) it indicates the part it is pointing to is hidden.

Product warranty is provided as part of John Deere's support program for customers who operate and maintain their equipment as described in this manual. The product warranty is explained on the warranty certificate you received from your dealer.

Record identification numbers. Be sure to record all the numbers to help in tracing the machine if it is stolen. You also need to give these numbers to your dealer when you order parts.

### DATE OF PURCHASE:

\_\_\_\_\_  
DEALER NAME:

\_\_\_\_\_  
DEALER PHONE:

\_\_\_\_\_  
SERIAL NUMBER (A):

-----

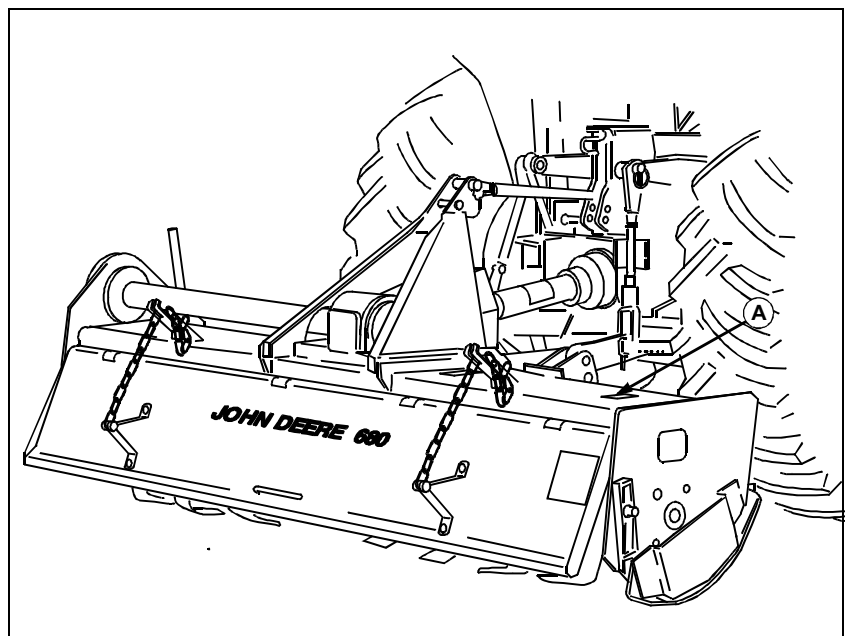
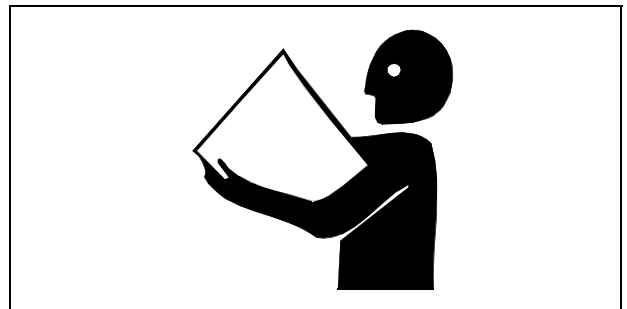

---

---

# TABLE OF CONTENTS

---

---

Safety Signs.....	1
Preparing Vehicle.....	3
Installing .....	5
Removing .....	9
Operating Machine .....	11
Replacement Parts .....	26
Service Machine Safely .....	27
Service .....	28
Troubleshooting .....	45
Storing Machine .....	46
Assembly .....	47
Specifications .....	57
Index .....	59
John Deere Service Literature .....	61

All information, illustrations and specifications in this manual are based on the latest information at the time of publication. The right is reserved to make changes at any time without notice.

COPYRIGHT© 1998  
Deere & Co.  
John Deere Worldwide Commercial and  
Consumer Equipment Division  
Horicon, WI  
All rights reserved

OMM137899 G8

# SAFETY SIGNS

## Safety-Alert Symbol

Read and recognize safety information. Be alert to the potential for personal injury when you see this safety-alert symbol.

On your machine safety labels, the words DANGER, WARNING, and CAUTION are used with this safety-alert symbol. DANGER identifies the most serious hazards. In this manual, the word CAUTION and this symbol call attention to safety messages.

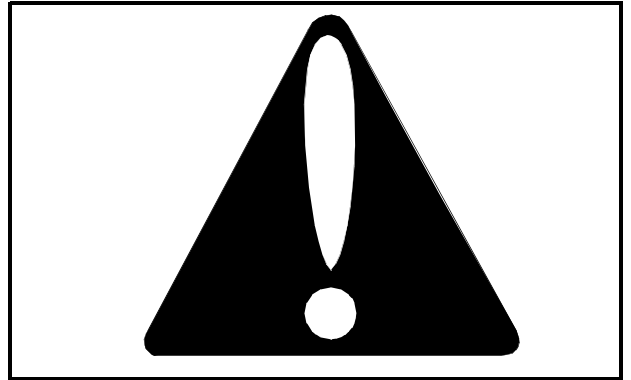

## Machine Safety Labels

### WARNING: AVOID INJURY FROM ROTATING KNIVES:

- Keep hands, feet and clothing away.

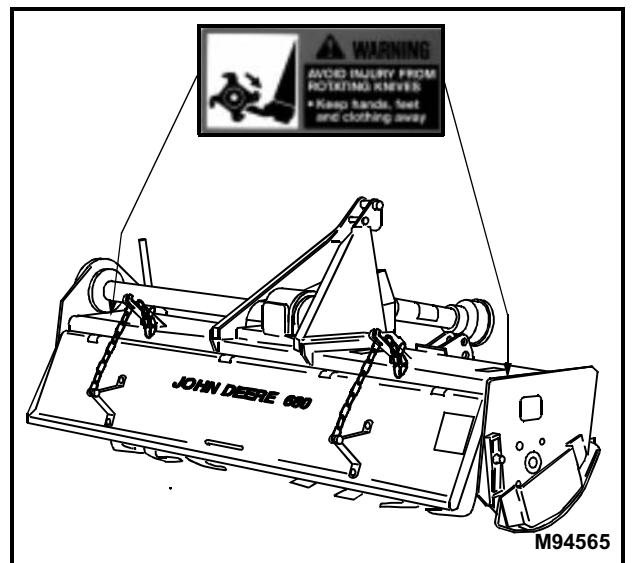

### WARNING: AVOID INJURY FROM PTO:

- Keep all shields in place.
- Keep hands, feet and clothing away.
- Operate only with 540 RPM.

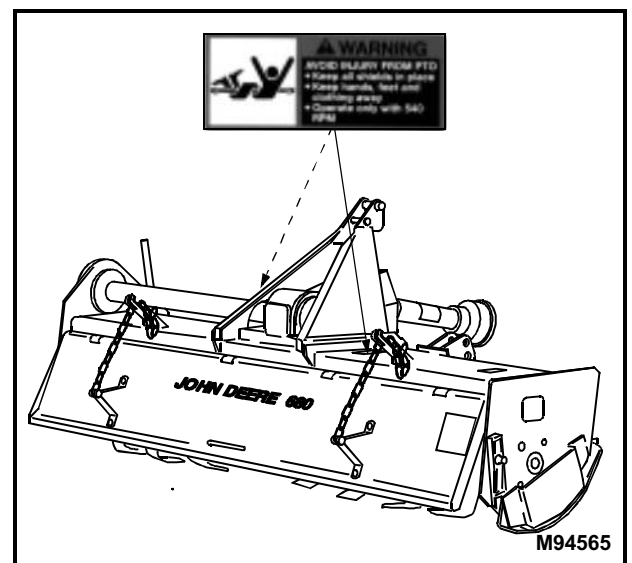

# SAFETY SIGNS

## CAUTION: AVOID INJURY

- Read Operator's Manual
- Ballast power unit per operator's manual
- Know location and function of controls
- Keep all shields in place
- Stay clear of power driven parts
- Never carry riders
- Keep people and pets a safe distance away from machine

## BEFORE DISMOUNTING OR SERVICING

- Shut off engine and remove key
- Lock brake for park
- Lower or block up machine

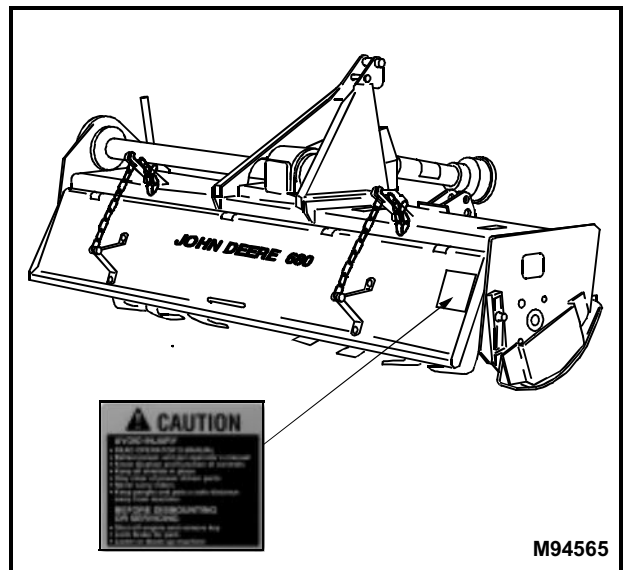

## DANGER: ROTATING DRIVELINE – CONTACT CAN CAUSE DEATH – KEEP AWAY! – DO NOT OPERATE WITHOUT:

- All driveline, tractor and equipment shields in place
- Drivelines securely attached at both ends
- Driveline shields that turn freely on driveline

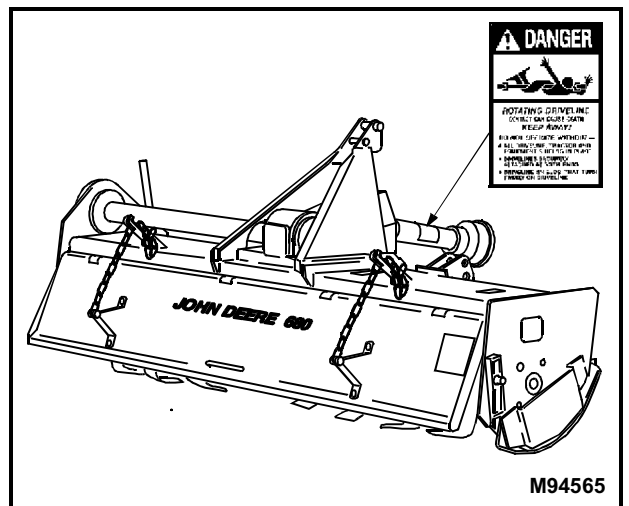

## DANGER: SHIELD MISSING DO NOT OPERATE

Picture Note: Separate telescoping driveshaft members to locate safety label. Label attached to outer profile tube.

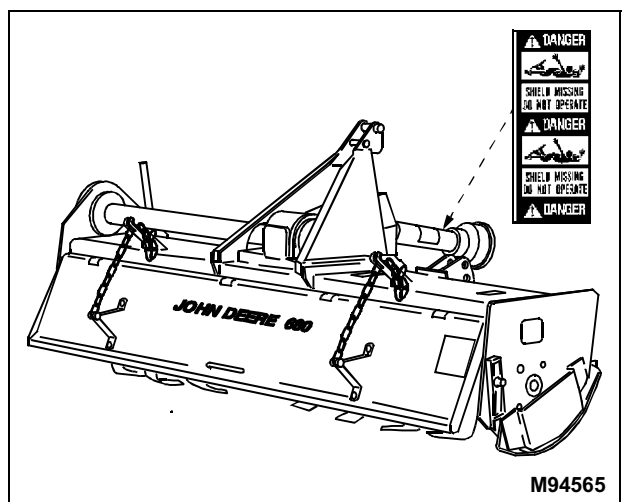

Thank you so much for reading.  
Please click the “Buy Now!”  
button below to download the  
complete manual.



After you pay.

You can download the most  
perfect and complete manual in  
the world immediately.

Our support email:

[ebooklibonline@outlook.com](mailto:ebooklibonline@outlook.com)