

100 QUICK-TATCH ONE-ROW CORN SNAPPER



JOHN DEERE

OPERATORS MANUAL 100 QUICK-TATCH ONE-ROW CORN SNAPPER

OMN11653 (01JUN53) English

OMN11653 (01JUN53)

LITHO IN THE U.S.A.
ENGLISH



INTRODUCTION

Back of your John Deere No. 100 Quik-Tatch Corn Snapper is an organization that has been building farm equipment for more than one hundred years. In the plant where your corn snapper was built, fine materials, high-grade workmanship, complete testing, and thorough inspection are combined to give you dependable performance and economical operation.

The way you operate your corn picker and the care you give it have much to do with the service and satisfaction you will get from it. This manual has been carefully prepared and illustrated to show you what to do, when to do it, and how to do it. Make it your guide. Study it carefully. Refer to it often. Keep it handy at all times for quick reference. Only by following the instructions it contains can you hope to get the most from your investment.

If you find you need information not covered in this manual, see your John Deere dealer. He has the latest information on how to get the best service from your machine and can give you prompt "know-how" service in the field or in his shop.

SERIAL NUMBER _____

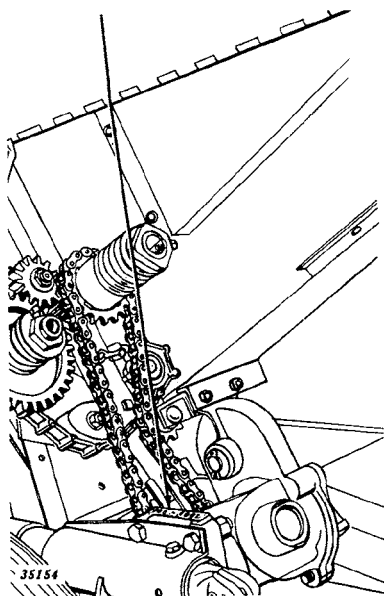

When in need of parts, go to your John Deere dealer. Be sure to give him the correct part number and a complete description of the part. This information can be obtained by referring to the exploded view section of this manual, where these parts can be readily and accurately identified. Also be sure to give him the serial number and the year purchased. This information should be recorded in the space provided on this page as soon as you have received your snapper.

LOCATION REFERENCES: "Right" and "Left," "Front" and "Rear," refer to the operator's "Right" or "Left," and "Front" or "Rear," when facing the same direction machine is headed or traveling.

TABLE OF CONTENTS

	<i>Page</i>
SPECIFICATIONS AND DATA.....	3
LUBRICATION.....	4-7
OPERATION.....	8-12
Breaking in the New Snapper—Starting in the Field.....	8
Operating Precautions.....	11
OPERATING ADJUSTMENTS.....	11-30
Tilting.....	11-13
Gatherers.....	14-15
Snapping Rolls.....	16-18
First-Elevator—Trash Rolls.....	19
Wagon Elevator—Shipping and Storage Wheel.....	20-21
Raising Jack—Fan.....	22-23
Slip Clutches.....	24
Chains—Drive Chains.....	24-27
Care of Rubber Tires.....	28
When the Season Is Over.....	30
PICKING DIFFICULTIES.....	31-37
EXTRA EQUIPMENT.....	38-40
Gatherer Fender Sticks—Spiral Strips for Snapping Rolls.....	38
Trash Knives for Snapping Rolls.....	39
Wagon Box Steel Flareboards—Weight Box.....	40
SHIPPING BUNDLES.....	41-43
ASSEMBLY INSTRUCTIONS.....	44-83
Section I—General Assembly Instructions.....	45-47
Section II—Connecting Snapper to John Deere Models “50,” “60,” “70,” “A,” “B,” and “G” Tractor Equipped with Powr- Trol.....	48-53
Section III—Connecting Snapper to John Deere Models “50,” “60,” “70,” “A,” “B,” and “G” Tractors without Powr-Trol (Hand Tilt).....	54-56
Section IV—Connecting Snapper to John Deere Model “40” Tractor.....	57-61
Section V—Connecting Snapper to John Deere Model “40” Standard Tractor.....	62-67
Section VI—Connecting Snapper to John Deere Model “MT” Tractor.....	68-70
Section VII—Connecting Snapper to John Deere Model “M” Tractor.....	71-76
Section VIII—Connecting Snapper to I.H.C. Farmall Models H, Super H, M, Super M, and MD Tractors.....	77-78
Section IX—Connecting Snapper to I.H.C. Farmall Models C and Super C Tractors.....	79-80
Section X—Connecting Snapper to Ford, Ferguson, and Ford- Ferguson Tractors.....	81-82
Section XI—Connecting Snapper to Allis-Chalmers Model WD Tractor.....	83
PARTS LIST AND ILLUSTRATIONS.....	85-151

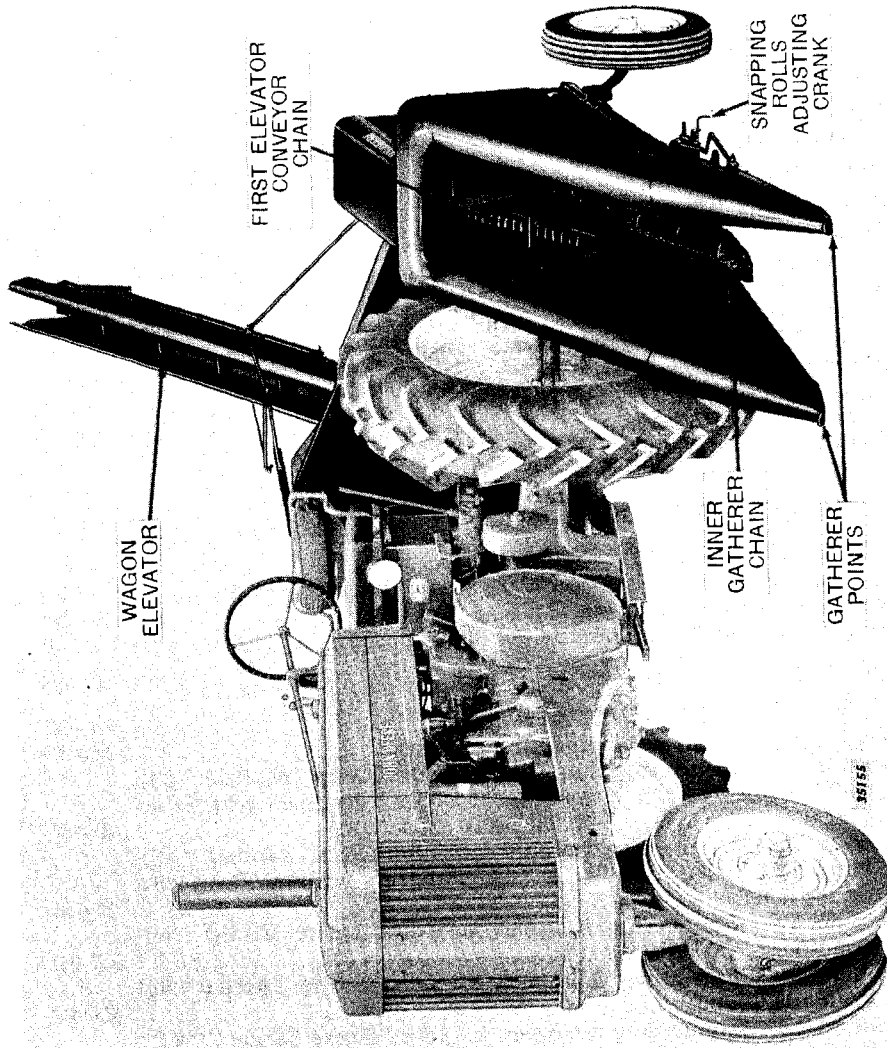

*Complete View of John Deere No. 100 Quik-Tatch Corn Snapper
with Model "60" Tractor*

SPECIFICATIONS AND DATA

No. of Rows.....	1
Right- or Left-Hand Machine.....	Left
Distance Center Line of Tractor to Corn Row.....	60" to 65"
Gatherer Points Hinged or Rigid.....	Hinged
Points Hinged Above or Below Gatherer Chain.....	Above
No. of Gatherer Chains per Snapping Unit.....	2
Type of Gatherer Chains.....	Steel Link
Min. Clearance between Gatherer Chains and Ground (Inches).....	0 - Up
Gatherer Chains Adjustable Laterally.....	No
Dist. Gath. Chains Ahead of Snapping Roll Entry.....	12"
Length Snapping Rolls.....	41"
Width Snapped Corn Elevator.....	6-1/2"
Cleaning Fan.....	Yes
Depth Ear Corn Elevator, Inches.....	7-1/2"
Width Ear Corn Elevator, Inches.....	6-1/2" - 10-1/2"
Offset of Hitch Point From Inside Row.....	69"
Dist. Inside Row to Wagon Center Line (with Wagon Hitch).....	5' 0"
Width Over-All for Transport.....	10' 4"
Over-All Width of Picker Only.....	8' 6"
Height with Wagon Elevator.....	9'
Length with Wagon Elevator.....	17' 9"
Tire Size.....	5:00 x 16, 4:00 x 9 (Caster Wheel)
Approx. Shipping Weight—with Take-Off Connection.....	1390 Lbs.

Tractor Tire Inflation: The small amount of weight added to the tractor by the No. 100 Quik-Tatch Corn Snapper does not require a special tire inflation table, so the regular tire inflation table included in the Tractor Operator's Manual will apply.

Thank you so much for reading.
Please click the “Buy Now!”
button below to download the
complete manual.



After you pay.

You can download the most
perfect and complete manual in
the world immediately.

Our support email:

ebooklibonline@outlook.com