

# 32B Pull-Type Sprayer



JOHN DEERE

## OPERATORS MANUAL

32B  
Pull-Type Sprayer

OMN159193 J0 English

OMN159193 J0

LITHO IN U.S.A.  
ENGLISH



## TO THE PURCHASER

Your new John Deere Sprayer is efficient and dependable. It will give long and efficient service if given proper care and operation.

This operator's manual contains information on the proper operation, adjustment, and maintenance of your new sprayer.

When in need of parts, see your John Deere dealer. He will furnish genuine John Deere parts and prompt and efficient service in the field or in the shop.

Right-hand and left-hand reference is determined by standing at the rear of the sprayer and facing the direction of travel.

Study this manual carefully. Keep it handy, in a safe place, for future reference.

The warranty on this sprayer appears on your copy of the purchase order which you should have received from your dealer when you purchased the sprayer.

**⚠** This safety alert symbol identifies important safety messages in this manual. When you see this symbol, be alert to the possibility of personal injury and carefully read the message that follows.

### SERIAL NUMBER

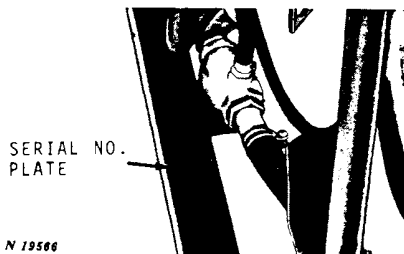

The sprayer serial number is stamped on a plate located on the tongue.

Write this serial number in the space provided below, for hand reference later.

SPRAYER SERIAL NUMBER . . . . .

DATE PURCHASED . . . . .

John Deere 32B Pull-Type Sprayer	
<b>Booms</b>	
6-Row . . . . .	<input type="checkbox"/>
8-Row . . . . .	<input type="checkbox"/>
8-Row Heavy-Duty . . . . .	<input type="checkbox"/>
12-Row (40-Ft.) . . . . .	<input type="checkbox"/>
<b>PTO PUMP</b>	
7-Roller N1-Resist . . . . .	<input type="checkbox"/>
Centrifugal Pump . . . . .	<input type="checkbox"/>
WIDE-SPRAY JET . . . . .	<input type="checkbox"/>
ROW-CROP DROPS . . . . .	<input type="checkbox"/>
HAND GUN — Light Duty <input type="checkbox"/> Regular Duty <input type="checkbox"/>	
25-Foot Hose . . . . .	<input type="checkbox"/>
BOOM EXTENSION NOZZLES . . . . .	<input type="checkbox"/>
<i>(To be filled in by purchaser)</i>	

## TABLE OF CONTENTS

	Page
Specifications . . . . .	2-3
Identification view . . . . .	3
Operation . . . . .	4-23
Hitching to tractor . . . . .	4
Adjusting wheel tread . . . . .	4
Filling tank with the PTO pump . . . . .	5
Transporting—6- or 8-Row Booms . . . . .	6-7
Transporting—8-Row (heavy-duty) or 12-Row (40-Ft.) Booms..	8
Controls . . . . .	9
Nozzles . . . . .	10-11
Sprayer calibration . . . . .	12-13
Nozzle tip selection chart . . . . .	13
Calibration chart . . . . .	14
Nozzle tip identification chart . . . . .	14
PTO pump . . . . .	15
Pump capacity . . . . .	15
Nozzle check valves . . . . .	16
Row-crop drops . . . . .	16
Boom extension nozzles . . . . .	16-17
Wide-spray jet and controls . . . . .	18-19
Hand gun . . . . .	20-21
Safety legs . . . . .	21
Safety suggestions . . . . .	22
Cleaning sprayer . . . . .	23
Lubrication . . . . .	24
Service . . . . .	24-33
Trouble Shooting . . . . .	34
Assembly . . . . .	35-45



## SPECIFICATIONS

### TYPE

The 32B Sprayer is a two-wheel, pull-type sprayer.

### TANK

200-gallon, translucent fiber glass.

### BOOMS

Regular—8-row booms (27-foot 1/2-inch) to cover eight 40-inch rows.

Optional—12-row booms (40-foot 4-1/2-inch) to cover twelve 40-inch rows, 8-row heavy-duty booms (27-foot 1/2-inch) to cover eight 40-inch rows, or 6-row booms (20-foot 4-1/2-inch) to cover six 40-inch rows.

Booms are made of square tubing. Nylon nozzles are clamped to the booms. Rubber boom hoses are connected to the nozzles. The nozzle clamps are adjustable for row widths of 24 to 40 inches. Spacing between nozzles can be adjusted from 12 to 20 inches. Booms are made in three sections with the center section stationary and the outer sections mounted on four-way hinges.

### PTO PUMP

Regular—Ni-Resist (nickel-iron alloy) seven-roller pump.

Optional—centrifugal pump.

### BOOM CONTROL

The boom control includes a two-position selector valve. Either half of the total boom coverage may be operated independently of the other half.

### WIDE-SPRAY JET

A wide-spray jet is available as optional equipment in lieu of the booms. It is used for broadcast spraying grains, pastures, etc.

### NOZZLES

The nozzle bodies, nozzle caps and strainer bodies are made of nylon. The nozzle and line strainer screen are made of stainless steel. The nozzle tips are made of brass or stainless steel.

### HAND GUN

A light or regular hand gun and controls may be ordered in lieu of the booms and boom controls.

Hand guns may also be used in conjunction with or independently of the boom-type or wide-spray jet-type sprayers. The hand gun is available with a 25-foot hose.

The hand gun may be used for spraying crops, animals, fence rows, etc.

**ROW-CROP DROPS**

Row-crop drops (18 inches long) are available for the booms. Each row-crop drop has two nozzles which can be turned up to spray the underside of the leaves, or down to spray the ground between the rows.

**BOOM EXTENSION NOZZLES**

These nozzles are used as boom extensions to expand the over-all width of boom coverage approximately 7 feet on each side of the regular sprayer pattern.

**TRAILER CLEARANCE**

30-3/4 inches with 7.60-15 tires.

Distance from nozzle tip to ground when boom is in working position:

Minimum—12 inches  
Maximum—36 inches

**OVER-ALL TRANSPORT DIMENSIONS WITH BOOMS**

Transport Width: Approximately 7 feet.

Transport Height with Booms Vertical:

6-Row Boom:	Minimum 9 feet 6 inches
	Maximum 11 feet 6 inches
8-Row Boom:	Minimum 13 feet
	Maximum 15 feet
8-Row Boom With Extensions:	Minimum 14 feet 8 inches
	Maximum 16 feet 8 inches

*(Specifications and design subject to change without notice.)*

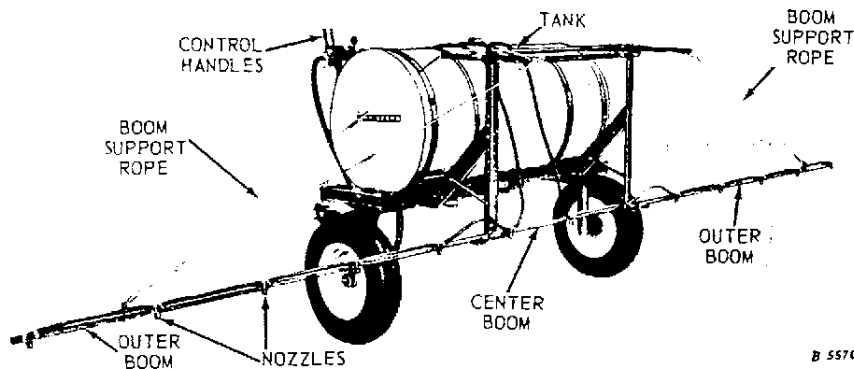

32B Sprayer with Booms in Working Position

B 5570



## OPERATION

### HITCHING TO TRACTOR

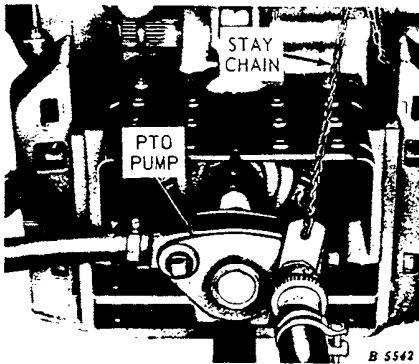

Adjust the tractor drawbar height to approximately 15 inches and set the drawbar in the short position.

Attach the drawbar clevis to the tractor drawbar.

Install the pump on the tractor PTO shaft.

Arrows on the pump ports indicate proper rotation.

Place the key between the splines on the PTO shaft and tighten the set screws against the key to secure pump on shaft.

Attach the stay chain to some fixed point on the tractor and adjust the length so it will hold pump in a horizontal position.

### ADJUSTING SPRAYER WHEEL TREAD

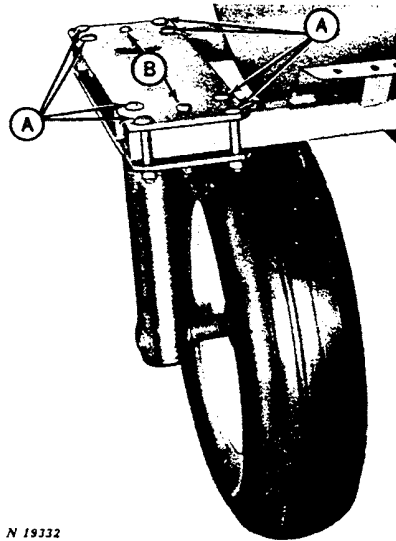

The wheel tread of the sprayer can be set on either 60 or 84 inches to accommodate row spacings of from 24 to 40 inches.

Additional adjustment of either 56 or 80 inches can be made as follows:

Loosen bolts "A," remove bolts "B," move wheel mounting bracket inward 2 inches, replace bolts "B," tighten bolts "A."

FILLING TANK WITH THE PTO PUMP

**⚠ WARNING**

To avoid backward tip-over:

- (1) Hitch trailer drawbar to tractor before filling tank.
- (2) When unhitching trailer drawbar from tractor with liquid in tank or the 40-ft. booms in transport position, hold the drawbar as firmly and as close to ground as possible.
- (3) If trailer is equipped with optional safety legs, lower them into proper position before unhitching trailer drawbar from tractor.

Obtain one length of 1-inch I.D. hose not over 50 feet long, with the female hose connection on one end and a strainer on the other end. Connect the female hose connection to the PTO pump where the suction hose was removed. Place the end of the hose with the strainer into the water reservoir or supply.

*NOTE: Do not place pump at height of more than 20 feet above source of water.*

Disconnect the discharge hose from the PTO pump.

The PTO pump can be used to fill the tank.

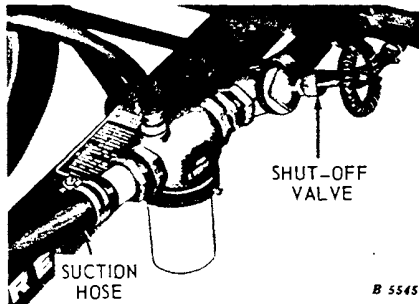

Turn the shut-off valve clockwise to the "OFF" position.

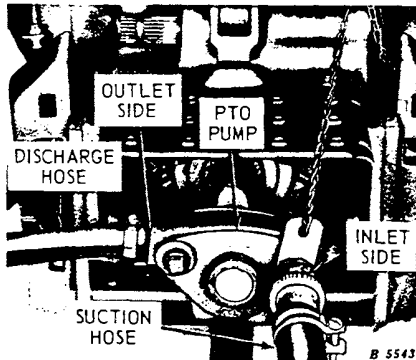

Disconnect the suction hose from the PTO pump.

Obtain a 3/4-inch hose of sufficient length to reach from the PTO pump to the tank. The 3/4-inch hose must have a female hose connection on one end. Connect the female hose connection to the PTO pump where the discharge hose was removed. Place the other end of the hose in the tank. Start the PTO pump.

*NOTE: The hoses used for filling the tank do not have to be chemical resistant.*

**IMPORTANT:** The resins in the fiberglass tank will deteriorate by prolonged exposure to strong alkaline materials such as aqua-ammonia. After strong alkaline materials are used, immediately flush out the tank and remove the lid until all vapors have escaped.

6 *Operation*

**TRANSPORTING—6-ROW OR 8-ROW (STANDARD) BOOMS**

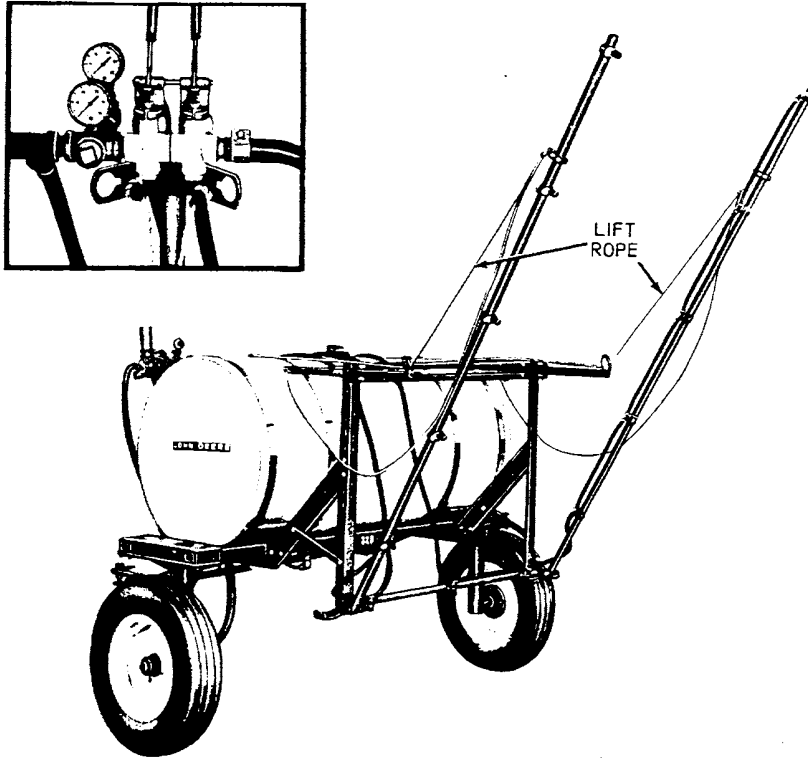

B 5573

*Lift Ropes Holding Booms up in Transport Position*

To transport the sprayer short distances pull the booms up with the lift rope. Reposition the inner rope stops on the lift rope, so that when the rope stops are inserted in the notches of the lift rope bracket, the booms will clear the ends of the boom frame.

To reduce transport height, reposition rope stops, swing booms rearward. If sprayer is equipped with eight-row booms, tie booms together with rope provided.

The booms may be swung straight back for transporting. This method of transporting is useful when the sprayer is equipped with row-crop drops.



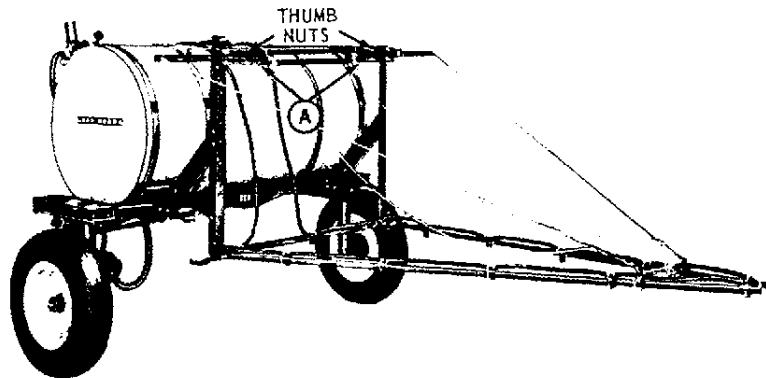

B 5374

*Booms Straight Back in Transport Position*

To position the booms straight back, remove the two thumb nuts and pins "A," swing the boom frame end around and install pins "A" as shown. Tie the booms together with rope provided.

When transporting the sprayer over rough ground, or for a long distance, secure the booms to the boom frame as follows.

Raise the outer boom sections straight up to the end of the boom frame and place them in the transport brackets. Secure the booms in place with pins "B."

**CAUTION:** When transporting the sprayer on a road or highway at night or during the day, use accessory lights and devices for adequate warning to the operators of other vehicles. In this regard check local governmental regulations. Various safety lights and devices are available from your John Deere dealer.

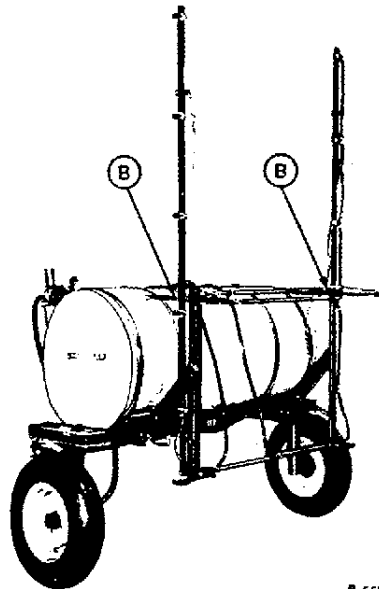

B 5375

*Booms Locked up in Transport Position*

## 8 Operation

### TRANSPORTING—8-ROW (HEAVY-DUTY) OR 12-ROW (40-FT.) BOOMS

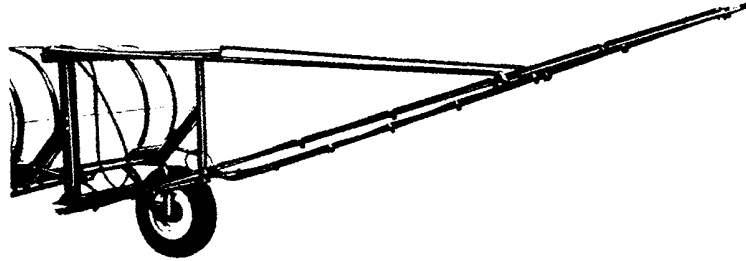

B 2091

Swing the booms back and place the "U" bar in the ends of the booms. Secure the "U" bar in place with the drilled pins and spring locking pins.

When the boom is in working position secure the "U" bar to the boom frame with the drilled pins and spring locking pins.

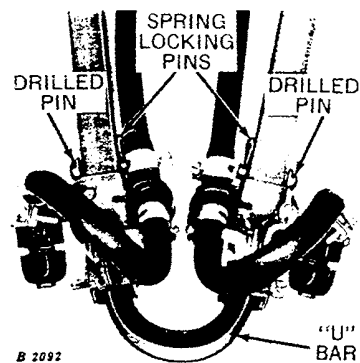

B 2092

### POSITIONING BOOMS

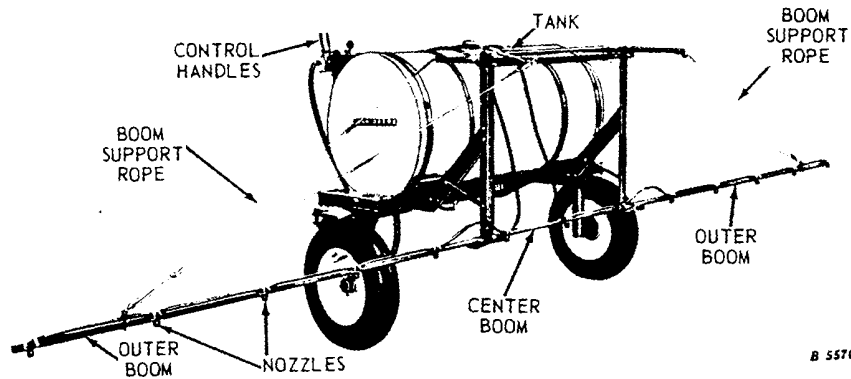

B 5570

Lower the outer booms to the operating height and adjust the rope stops on the boom support ropes so that the booms are level and in line with center boom section.

Adjust the height of the booms so there is approximately 18 inches of clearance between the nozzle tips and the surface to be sprayed.

Thank you so much for reading.  
Please click the “Buy Now!”  
button below to download the  
complete manual.



After you pay.

You can download the most  
perfect and complete manual in  
the world immediately.

Our support email:

[ebooklibonline@outlook.com](mailto:ebooklibonline@outlook.com)