

500 D Series Integral Tool Bar



JOHN DEERE

OPERATORS MANUAL 500 D Series Integral Tool Bar

OMN97660 (01JUL63) English

OMN97660 (01JUL63)

LITHO IN U.S.A.
ENGLISH



To the purchaser



This manual contains valuable information about your new John Deere 500D Series Tool Bar. It has been carefully prepared and illustrated. In it, you will find instructions and helpful suggestions for operating, adjusting, attaching, transporting, lubricating and servicing your new tool bar. You will also find information about tools and attachments for adapting your tool bar to work properly in all types of field conditions.

Your new tool bar was built to rigid manufacturing standards. Material and workmanship are the

best. Precision production methods and accurately controlled heat-treating assure maximum strength and long life for every part.

Keep this manual in a convenient place for quick and easy reference. Study this manual carefully. You have purchased a dependable and sturdy implement, but only by proper care and operation can you expect to receive the service and long life designed and built into it.

Give your tool bar proper attention during slack periods. By doing this, it will always be ready, without delay, when you need it.

Sometime in the future, your tool bar may need new parts to replace those that are worn or broken. If so, go to your John Deere dealer. Provide him with the number of your tool bar and the date purchased. Record this information in the space provided below, so it will be readily accessible when it is needed.

Location references

Right-hand and left-hand references are determined by standing at the rear of the tool bar and facing in the direction of travel.

John Deere 500D Series Integral Tool Bar

No. of Tool Bar

No. of Tool Equipment

Date Purchased 19

(To be filled in by Purchaser)

Contents

	Page
SPECIFICATIONS.....	4-7
OPERATION AND ADJUSTMENT.....	8-22
On 1010 Tractor with Universal 3-Point Hitch.....	8-9
On 2010, 3020, 3010, 4020, and 4010 Tractors with Universal 3- Point Hitch.....	10-11
On 530, 630, 730, 520, 620, and 720 Tractors with Universal 3- Point Hitch.....	12-14
On 1010, 430, and 420 Crawler Tractors with 3-Point Hitch.....	15-16
On 50, 60, and 70 Tractors with 800 Series 3-Point Hitch.....	17-18
Safety Suggestions.....	19
Attaching Tool Bar to 3-Point Hitch without Quik Coupler.....	20
Attaching Tool Bar to Quik Coupler.....	21
Adjusting Hitch Pins and Mast.....	22
LUBRICATION.....	23
MAINTENANCE.....	23
SPECIAL EQUIPMENT.....	24-29
No. 1 Heavy-Duty Attachment.....	24
Rolling Coulters and Chisel Adapters.....	24
Short Bar Spacers.....	24
Standards.....	25
Tool Equipment.....	25-26
Gauge Wheels.....	27
1000 Series Rod Weeder.....	28
Planting Attachments.....	28-29
Mast for Hi-Crop Tractors.....	29
Mast for Planting Attachments.....	29
SHIPPING BUNDLES.....	30-34
ASSEMBLY.....	35-69

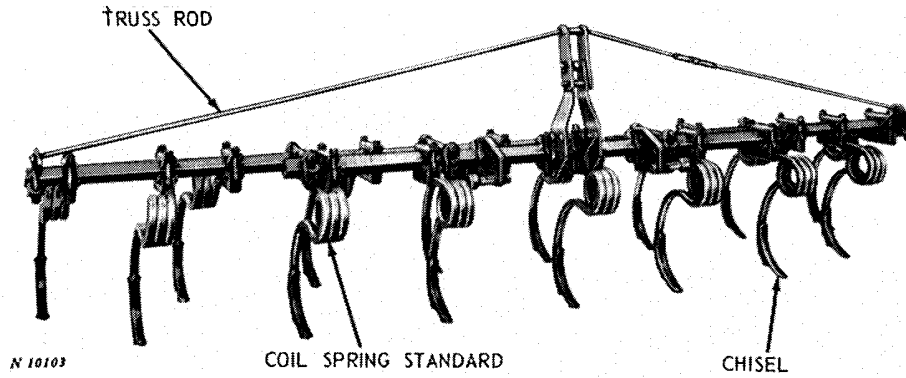

John Deere 514D Tool Bar with TE-106 Tool Equipment

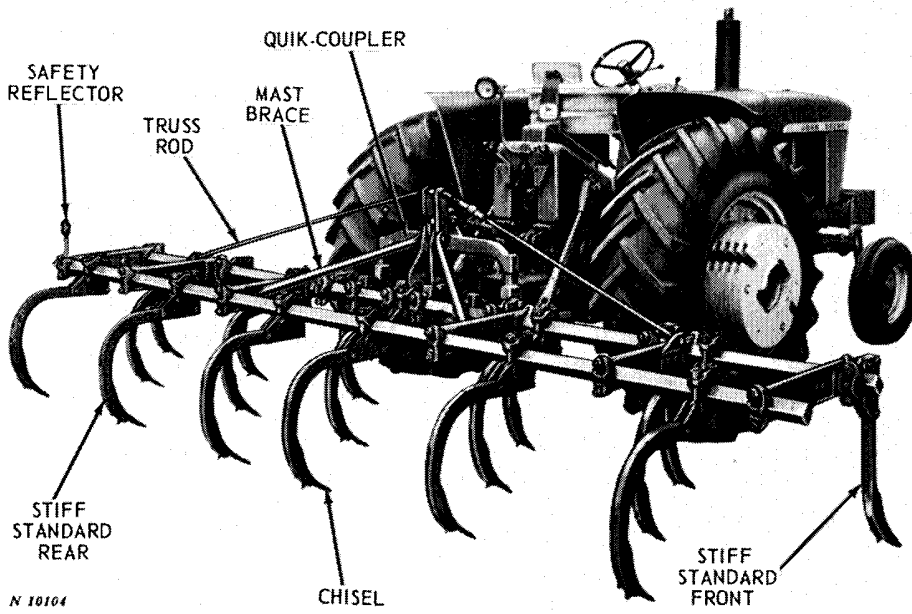

John Deere 526D Tool Bar with TE-175 Tool Equipment

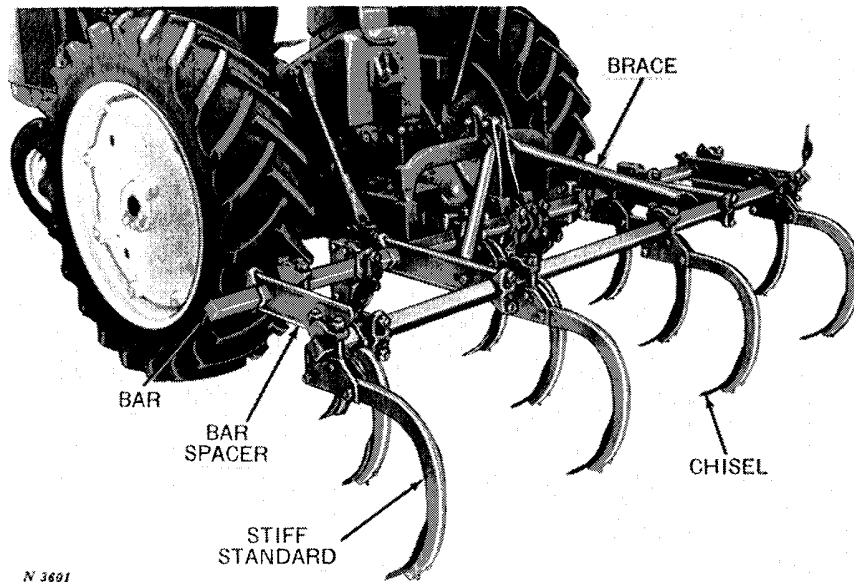

N 3691

John Deere 520D Tool Bar with TE-33 Tool Equipment

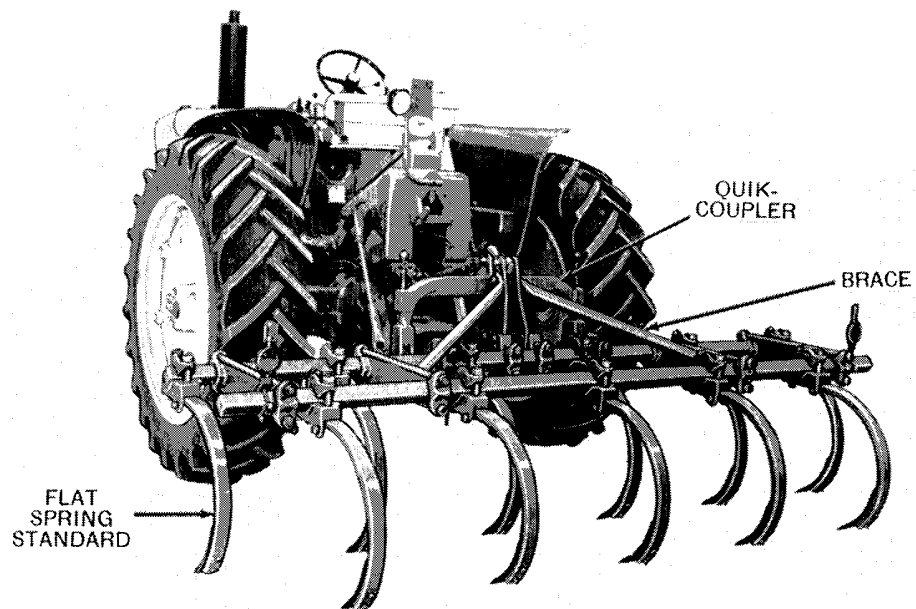

N 3692

John Deere 520D Tool Bar with TE-34 Tool Equipment

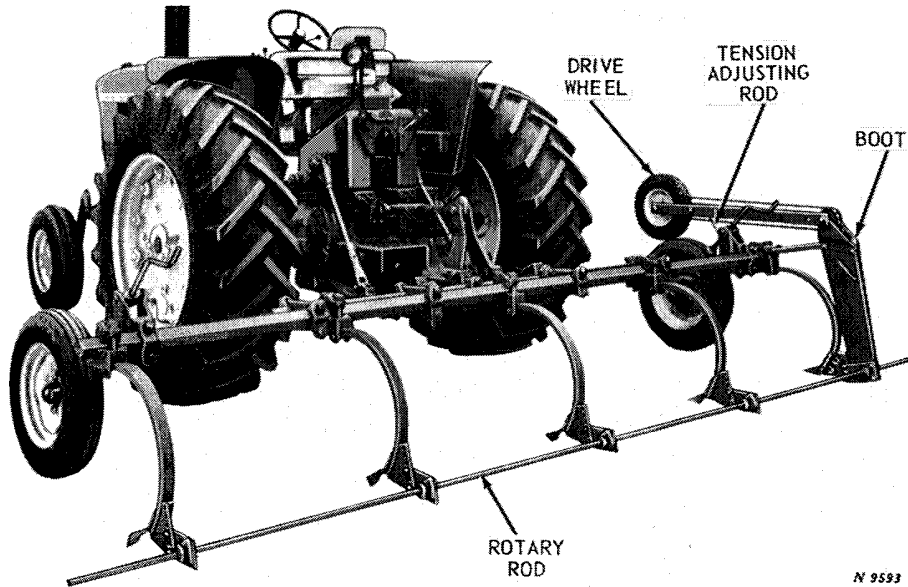

John Deere 514D Tool Bar with 1514 Rod Weeder Attachment

Specifications

Tool bar models

- 510D —Single Tool Bar, 10-foot long
- 512D —Single Tool Bar, 12-foot long
- 514D —Single Tool Bar, 14-foot long with 8-foot reinforcing bar and truss rod
- 516D —Single Tool Bar, 16-foot long with 10-foot reinforcing bar and truss rod
- 518D —Single Tool Bar, 8-foot long
- 520D —Double Tool Bar, 10-foot long
- 522D —Double Tool Bar, 12-foot long
- 524D —Double Tool Bar, 14-foot long
- 526D —Double Tool Bar, 16-foot long with truss rod
- 528D —Double Tool Bar, 8-foot long
- 580HD—Heavy-Duty Single Tool Bar, 10-foot long with 8-foot reinforcing bar
- 582HD—Heavy-Duty Single Tool Bar, 12-foot long with 8-foot reinforcing bar

Tractor required

The size of the tractor to be used will depend upon the ground condition, size of the tool bar and the number of standards used on the tool bar. The tractor must be equipped with a category 1 or category 2, 3-point hitch.

Tool equipment

For 510D Tool Bar:

- TE-38—11 Stiff Standards (Y916N, 14-Inch Chisels)
- TE-39—11 Coil-Spring Standards, 1-1/4-Inch (Y938N, 11-Inch Chisels)
- TE-62—11 Coil-Spring Standards, 1-Inch (Y850AN, 11-Inch Chisels)

For 512D Tool Bar:

- TE-40—13 Stiff Standards (Y916N, 14-Inch Chisels)
- TE-41—13 Coil-Spring Standards, 1-1/4-Inch (Y938N, 11-Inch Chisels)
- TE-93—13 Coil-Spring Standards, 1-Inch (Y850AN, 11-Inch Chisels)

For 514D Tool Bar:

- TE-105—15 Stiff Standards (Y916N, 14-Inch Chisels)
- TE-106—15 Coil-Spring Standards, 1-1/4-Inch (Y938N, 11-Inch Chisels)
- TE-107—15 Coil-Spring Standards, 1-Inch (Y850AN, 11-Inch Chisels)
- TE-156—5 Flat Cushion Spring Standards (Y916N, 14-Inch Chisel)
- TE-157—5 Flat Spring Standards (Y916N, 14-Inch Chisel)

For 516D Tool Bar:

- TE-156—5 Flat Cushion Spring Standards (Y916N, 14-Inch Chisel)
- TE-157—5 Flat Spring Standards (Y916N, 14-Inch Chisel)
- TE-170—17 Coil-Spring Standards, 1-Inch (Y850AN, 12-Inch Chisel)
- TE-172—17 Coil-Spring Standards, 1-1/4-Inch (Y938N, 11-Inch Chisel)
- TE-174—17 Stiff Standards (Y916N, 14-Inch Chisel)

For 518D Tool Bar:

- TE-36—9 Stiff Standards (Y916N, 14-Inch Chisels)
- TE-37—7 Coil-Spring Standards, 1-1/4-Inch (Y938N, 11-Inch Chisels)
- TB-203—7 Coil-Spring Standards, 1-Inch (Y850AN, 11-Inch Chisels)

For 520D Tool Bar:

- TE-1 —5 Sub-Surface Sweep Standards (YA905N, 30-Inch Sweeps)
- TE-33—11 Stiff Standards (Y916N, 14-Inch Chisels)
- TE-34—11 Flat Spring Standards (Y916N, 14-Inch Chisels)
- TE-35—11 Coil-Spring Standards, 1-1/4-Inch (Y938N, 11-Inch Chisels)
- TE-63—11 Coil-Spring Standards, 1-Inch (Y850AN, 11-Inch Chisels)
- TE-88—11 Flat Cushion Spring Standards (Y916N, 14-Inch Chisels)

6 specifications

For 522D Tool Bar:

- TE-2 —7 Sub-Surface Sweep Standards (YA905N, 30-Inch Sweeps)
- TE-26—13 Stiff Standards (Y916N, 14-Inch Chisels)
- TE-27—13 Flat Spring Standards (Y916N, 14-Inch Chisels)
- TE-28—13 Coil-Spring Standards, 1-1/4-Inch (Y938N, 11-Inch Chisels)
- TE-90—13 Flat Cushion Spring Standards (Y916N, 14-Inch Chisels)
- TE-94—13 Coil-Spring Standards, 1-Inch (Y850AN, 11-Inch Chisels)

For 524D Tool Bar:

- TE-2 —7 Sub-Surface Sweep Standards (YA905N, 30-Inch Sweeps)
- TE-91—15 Flat Cushion Spring Standards (Y916N, 14-Inch Chisel)
- TE-92—15 Flat Spring Standards (Y916N, 14-Inch Chisels)
- TE-95—15 Coil-Spring Standards, 1-Inch (Y938N, 11-Inch Chisels)
- TE-96—15 Coil-Spring Standards, 1-1/4-Inch (Y938N, 11-Inch Chisels)
- TE-97—15 Stiff Standards (Y916N, 14-Inch Chisels)

For 526D Tool Bar:

- TE-171—17 Coil-Spring Standards, 1-Inch (Y850N, 12-Inch Chisel)
- TE-173—17 Coil-Spring Standards, 1-1/4-Inch (Y938N, 11-Inch Chisel)
- TE-175—17 Stiff Standards (Y916N, 14-Inch Chisel)
- TE-176—17 Flat Cushion Spring Standard (Y916N, 14-Inch Chisel)
- TE-177—17 Flat Spring Standards (Y916N, 14-Inch Chisel)
- TE-178—9 Sub-Surface Sweep Standard (YA905N, 30-Inch Sweeps)

For 528D Tool Bar:

- TE-29 3 Sub-Surface Sweep Standards (YA905N, 30-Inch Sweeps)
- TE-30—9 Stiff Standards (Y916N, 14-Inch Chisels)
- TE-31—9 Flat Spring Standards (Y916N, 14-Inch Chisels)
- TE-32—9 Coil-Spring Standards, 1-1/4-Inch (Y938N, 11-Inch Chisels)
- TE-46—5 Flat Cushion Spring Standards (Y916N, 14-Inch Chisels)
- TE-48—9 Flat Cushion Spring Standards (Y916N, 14-Inch Chisels)
- TE-104—9 Coil-Spring Standards, 1-Inch (Y850AN, 11-Inch Chisels)

For 580HD Heavy-Duty Tool Bar:

- TE-38—11 Stiff Standards (Y916N, 14-Inch Chisel)
- TE-39—11 Coil-Spring Standards, 1-1/4-Inch (Y938N, 11-Inch Heavy-Duty Chisel)
- TE-62—11 Coil-Spring Standards, 1-Inch (Y850N, 11-Inch Double Point Chisel)

For 582HD Heavy-Duty Tool Bar:

TE-40—13 Stiff Standards (Y916N, 14-Inch Chisel)

TE-41—13 Coil-Spring Standards, 1-1/4-Inch (Y938N, 11-Inch Heavy-Duty Chisel)

TE-93—13 Coil-Spring Standards, 1-Inch (Y850N, 11-Inch Double Point Chisel)

Special equipment

Gauge wheels:

TE-49—Clamp-Adjusting, Semi-Pneumatic, Gauge Wheels (4 x 16-Inch Tires)

TE-50—Clamp-Adjusting, Pneumatic, Gauge Wheels (5.90 x 15 Tires)

TE-51—Crank-Adjusting, Pneumatic, Gauge Wheels (5.90 x 15 Tires)

Hitch parts:

Hitch Pin Parts for tractors with category 1 hitch.

Mast Adapter for 800 Series Hitch.

Hitch Mast for Hi-Crop Tractors.

Hitch Mast for 24-B and 25-B Planter Attachments with single guide coulter.

Bar spacers:

6-1/2-inch size.

Truss rods:

For 522D and 524D Tool Bars.

Planting attachments:

PA300 Series, 70 Series Flexi-Planters, and 23R, 24B, and 25B Series Unit Planters; all available with wide choice of optional equipment. Fertilizing equipment for PA300, 24B, and 25B. Insecticide attachment for PA300.

1000 Series Rod Weeder:

For 512D, 514D, 520D, 522D, 524D, 528D, and 582HD Tool Bars.

No. 1 heavy-duty attachment.

Chisel adapters:

For use with SC723 Sub-Surface Standards.

(Specifications and design subject to change without notice)

Operation and adjustment

On 1010 Tractors with 3-point hitch

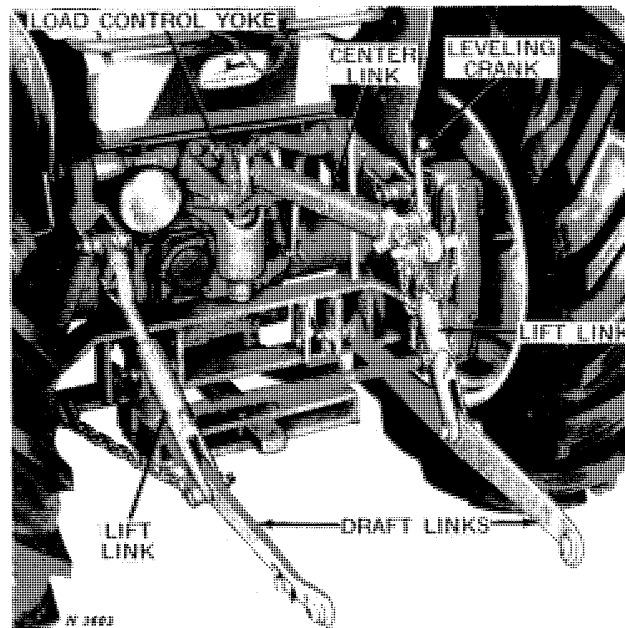

Wheel spacing

Set the tractor wheels for the spacing required. See pages 51 and 52. The proper setting of the wheels is important to do a good job. When adjusting, the wheels must be spaced equi-distant from the center of the tractor. Refer to your tractor operator's manual for instructions on how to change the rear wheel spacing.

Tire inflation

Refer to your tractor operator's manual for tractor tire inflation.

Front end weights

Additional front end weight for the tractor is required with the tool bar. The exact amount will depend upon the ground conditions and the tool equipment used.

Dual hydraulic system

If the tractor has a dual hydraulic system, set it for parallel lift arm operation. See your tractor operator's manual.

Thank you so much for reading.
Please click the “Buy Now!”
button below to download the
complete manual.



After you pay.

You can download the most
perfect and complete manual in
the world immediately.

Our support email:

ebooklibonline@outlook.com