

PW150-1 S/N 1001-UP
PW150-1 S/N 1001-UP

Item	Part Name
	6D95L-1C S/N 10001-UP
10	ENGINE RELATED PARTS AND ELECTRICAL SYSTEM
20	TRAVEL AND TRANSMISSION
30	AXLE?WHEELS AND STEERING SYSTEM
40	SWING AND CONTROL SYSTEM
50	REVOLVING FRAME?CHASSIS AND CAB
60	WORK EQUIPMENT CONTROL SYSTEM
70	WORK EQUIPMENT
80	OPTIONAL PARTS
90	SPECIAL APPLICATION PARTS?MARK PLATE?TOOL AND KIT

PW150-1 S/N 1001-UP
ENGINE RELATED PARTS AND ELECTRICAL SYSTEM

Item	Part Name	Qty
10	ENGINE MOUNT	1
20	POWER TAKE OFF	1
30	AIR CLEANER CONNECTION AND STEP	1
40	FUEL CONTROL LEVER	1
50	RADIATOR AND OIL COOLER	1
60	RADIATOR MOUNT AND PIPING	1
70	FUEL PIPING	1
80	BATTERY(#1001-1117)	1
90	BATTERY(#1118-)	1
100	BATTERY (COLD TERRAIN SPEC.)	1
110	INSTRUMENT PANEL	1
120	ELECTRICAL SYSTEM (1/2)	1
130	ELECTRICAL SYSTEM (2/2)	1

PW150-1 S/N 1001-UP
 @@08495@

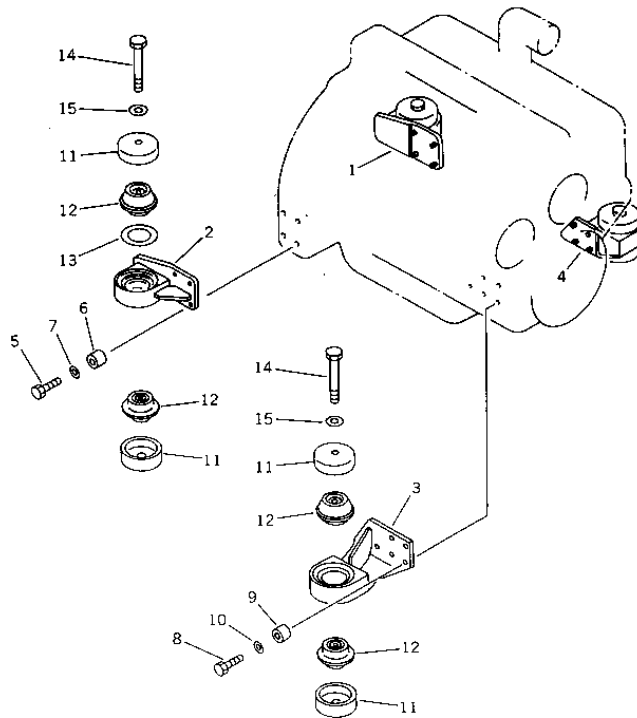

Ref. 1001

Page 030010

PW150-1 S/N 1001-UP
 ENGINE MOUNT

Item	Part No.	Part Name	Qty	Serial No.
1	203-01-42110	BRACKET	1	1001-
2	203-01-42120	BRACKET	1	1001-
3	20G-01-11231	BRACKET	1	1001-
4	20G-01-11241	BRACKET	1	1001-
5	01010-51255	BOLT	8	1001-
6	6131-22-3750	BOSS	8	1001-
7	01643-31232	WASHER	8	1001-
8	01010-51050	BOLT	8	1001-
9	6631-11-5630	SPACER	8	1001-
10	01643-31032	WASHER	8	1001-
11	203-01-32110	STOPPER	8	1001-
12	113-01-41210	CUSHION	8	1436-
	113-01-21110	CUSHION	8	1001-1435
13	20S-71-11230	SHIM, 1.0MM	2	1001-
14	01011-51625	BOLT	4	1001-
15	01643-31645	WASHER	4	1001-

PW150-1 S/N 1001-UP

@@A0839@

FIG.1011
パワータークオフ
 POWER TAKE OFF

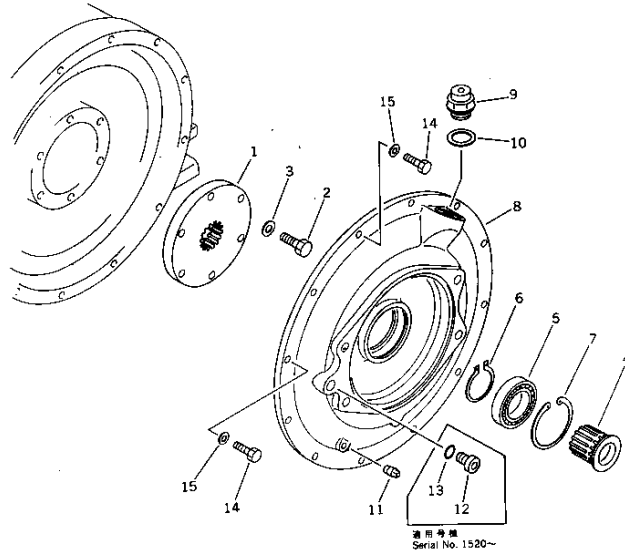

Ref. 1011

Page 030020

PW150-1 S/N 1001-UP
 POWER TAKE OFF

Item	Part No.	Part Name	Qty	Serial No.
1	203-01-41120	COUPLING	1	1001-
2	01010-51240	BOLT	6	1001-
3	01643-31232	WASHER	6	1001-
4	203-01-41130	SHAFT	1	1001-
5	06045-06010	BEARING	1	1001-
6	04064-05020	RING,SNAP	1	1001-
7	04065-08025	RING,SNAP	1	1001-
8	203-01-56160	CASE	1	1520-
	203-01-41111	COVER	1	1001-1519
9	07030-03034	BREATHER	1	1001-
10	07005-03016	GASKET	1	1001-
11	07042-30108	PLUG	1	1001-
12	07040-12414	PLUG	1	1520-
13	07002-02434	O-RING	1	1520-
14	01010-51030	BOLT	12	1001-
15	01643-31032	WASHER	12	1001-

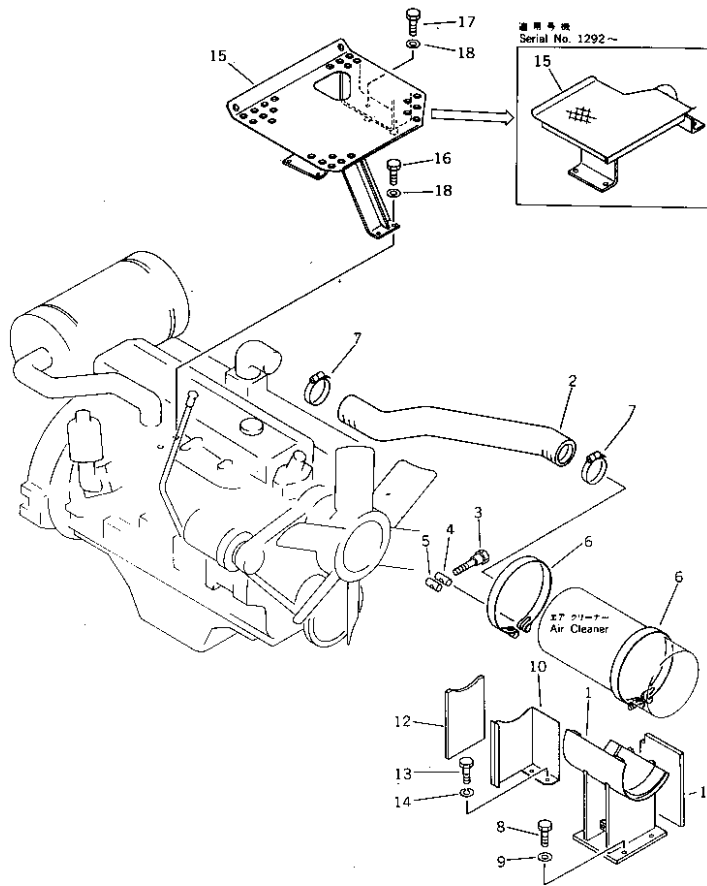

PW150-1 S/N 1001-UP
AIR CLEANER CONNECTION AND STEP

Item	Part No.	Part Name	Qty	Serial No.
1	20G-01-12112	BRACKET	1	1001-
2	20G-01-12122	HOSE	1	1001-
3	6110-23-6520	BOLT	2	1001-
4	6110-21-6530	PIN	2	1001-
5	6110-21-6540	PIN, WITH THREAD	2	1001-
6	6131-11-4510	BAND	2	1001-
7	07281-01029	CLAMP	2	1001-
8	01010-51225	BOLT	4	1001-
9	01643-31232	WASHER	4	1001-
10	20G-01-12140	PLATE	1	1001-
11	20G-01-12150	SHEET	1	1001-
12	20G-01-12160	SHEET	1	1001-
13	01010-51220	BOLT	2	1001-
14	01602-01236	WASHER,SPRING	2	1001-
15	203-01-41263	STEP	1	1292-
	203-01-41261	STEP	1	1001-1291
16	01010-51025	BOLT	2	1292-
	01010-51025	BOLT	4	1001-1291
17	01010-51070	BOLT	2	1001-
18	01643-31032	WASHER	4	1292-
	01643-31032	WASHER	6	1001-1291

PW150-1 S/N 1001-UP
 @@01031@

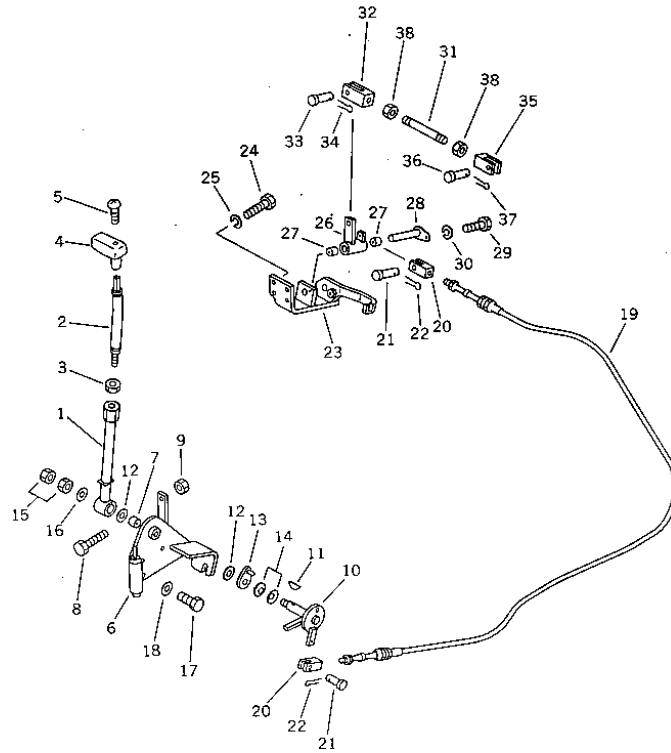

Ref. 1101

Page 030040

PW150-1 S/N 1001-UP
 FUEL CONTROL LEVER

Item	Part No.	Part Name	Qty	Serial No.
1	20G-43-11111	LEVER	1	1001-
2	20G-43-11190	ROD	1	1001-
3	01582-11411	NUT	1	1001-
4	20X-43-11270	KNOB	1	1001-
5	01225-40625	SCREW	1	1001-
6	20G-43-11121	BRACKET	1	1001-
7	09350-01420	BUSHING	1	1001-
8	01016-31060	BOLT	1	1001-
9	01580-11008	NUT	1	1001-
10	20G-43-11141	SHAFT	1	1001-
11	04010-00516	KEY	1	1001-
12	10E-43-11160	FACING	2	1001-
13	20N-43-24130	PLATE	1	1001-
14	101-854-9355	SPRING	2	1001-
15	01583-11207	NUT	2	1001-
16	01640-21223	WASHER	1	1001-
17	01010-51030	BOLT	4	1001-
18	01643-31032	WASHER	4	1001-
19	20G-43-11151	CABLE	1	1001-
20	04211-20500	YOKE	2	1001-
21	04205-10514	PIN	2	1001-
22	04050-11208	PIN,COTTER	2	1001-
23	20G-43-11131	BRACKET	1	1001-
24	01010-51025	BOLT	4	1001-
25	01602-21030	WASHER,SPRING	4	1001-
26	20G-43-11161	LEVER	1	1001-
27	09350-02530	BUSHING	2	1001-
28	20G-43-11180	SHAFT	1	1001-
29	01010-51030	BOLT	1	1001-

PW150-1 S/N 1001-UP
FUEL CONTROL LEVER

Item	Part No.	Part Name	Qty	Serial No.
30	01602-21030	WASHER,SPRING	1	1001-
31	04245-41013	ROD	1	1001-
32	04211-21055	YOKE	1	1001-
33	04205-11028	PIN	1	1001-
34	04050-13015	PIN,COTTER	1	1001-
35	201-43-21370	YOKE	1	1001-
36	04205-10622	PIN	1	1001-
37	04050-11612	PIN,COTTER	1	1001-
38	01582-11008	NUT	2	1001-

PW150-1 S/N 1001-UP
 @@01032@

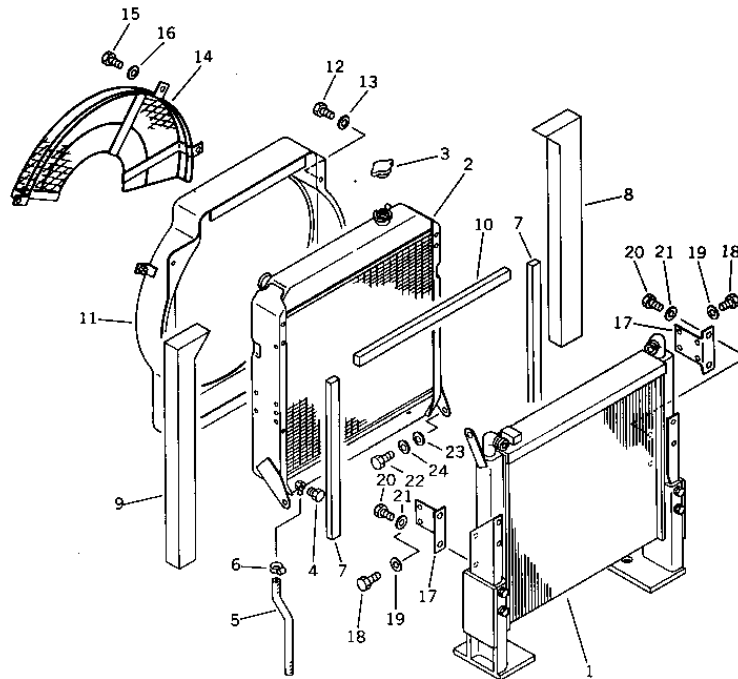

Ref. 1201

Page 030050

PW150-1 S/N 1001-UP
 RADIATOR AND OIL COOLER

Item	Part No.	Part Name	Qty	Serial No.
1	20G-03-11202	OIL COOLER ASS'Y	1	1501-
	20G-03-11201	OIL COOLER ASS'Y	1	1001-1500
	20G-03-00010	RADIATOR ASS'Y	1	1001-
2	☆	· CORE	1	1001-
3	203-03-41280	· CAP	1	1001-
4	205-03-62660	· PLUG	1	1001-
	07000-01007	· · O-RING	1	1001-
5	205-03-62650	· HOSE	1	1001-
6	07280-00910	· CLAMP	1	1001-
7	20G-03-11330	SHEET	2	1284-
	20G-03-11150	SHEET	2	1001-1283
8	20G-03-11260	CUSHION	1	1001-
9	20G-03-11270	CUSHION	1	1001-
10	20G-03-11320	SHEET	1	1001-
11	20G-03-11340	SHROUD	1	1284-
	20G-03-11121	SHROUD	1	1001-1283
12	01010-50816	BOLT	4	1001-
13	01643-30823	WASHER	4	1001-
14	20G-03-11350	NET	1	1284-
	20G-03-11131	NET	1	1001-1283
15	01010-51025	BOLT	3	1001-
16	01643-31032	WASHER	3	1001-
17	20G-03-11140	PLATE	2	1001-
18	01010-50816	BOLT	8	1001-
19	01643-30823	WASHER	8	1001-
20	01010-51020	BOLT	4	1001-
21	01643-31032	WASHER	4	1001-
22	01010-51025	BOLT	2	1001-
23	01643-31032	WASHER	2	1001-

PW150-1 S/N 1001-UP
RADIATOR AND OIL COOLER

Item	Part No.	Part Name	Qty	Serial No.
24	01642-21216	WASHER	2	1001-

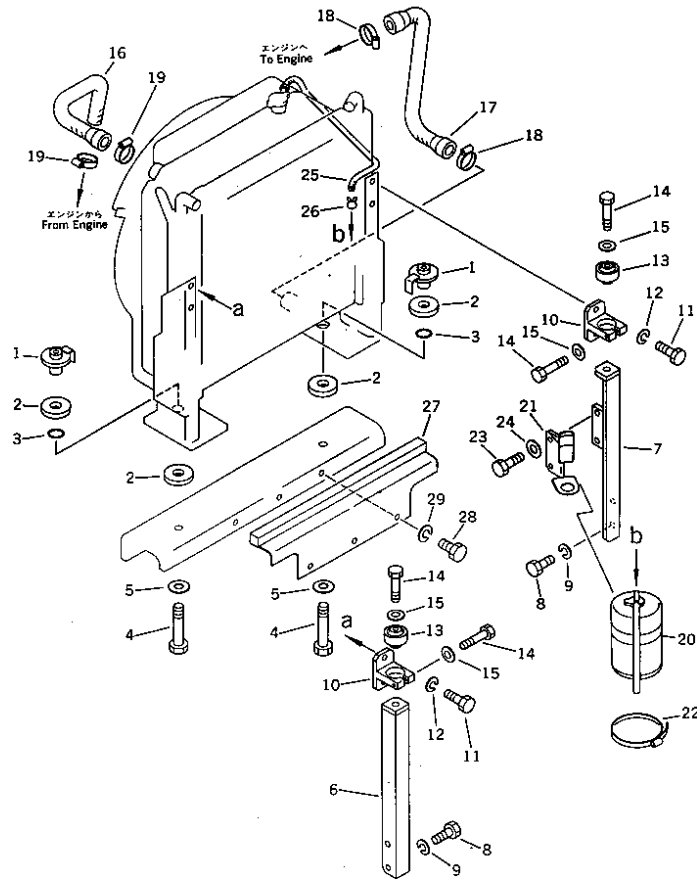

PW150-1 S/N 1001-UP
RADIATOR MOUNT AND PIPING

Item	Part No.	Part Name	Qty	Serial No.
1	21K-03-12650	COLLAR	2	1001-
2	205-03-62680	CUSHION	4	1001-
3	07000-03022	O-RING	2	1001-
4	01010-51275	BOLT	2	1001-
5	01643-31232	WASHER	2	1001-
6	20G-03-11250	BRACKET	1	1001-
7	20G-03-11241	BRACKET	1	1001-
8	01010-51225	BOLT	4	1001-
9	01602-21236	WASHER,SPRING	4	1001-
10	203-03-41190	BRACKET	2	1001-
11	01010-51025	BOLT	4	1001-
12	01602-21030	WASHER,SPRING	4	1001-
13	135-03-12110	DAMPER	2	1001-
14	01010-51260	BOLT	4	1001-
15	01643-31232	WASHER	4	1001-
16	20G-03-11171	HOSE	1	1001-
17	20G-03-11163	HOSE	1	1001-
18	207-09-11110	CLAMP	2	1433-
	□07281-00489	CLAMP	2	1001-1432
19	208-09-11120	CLAMP	2	1433-
	□07281-00709	CLAMP	2	1001-1432
20	203-03-41230	TANK	1	1001-
21	203-03-41360	BRACKET	1	1001-
22	07281-01469	CLAMP	1	1001-
23	01010-51020	BOLT	2	1001-
24	01643-31032	WASHER	2	1001-
25	20D-03-41450	HOSE	1	1175-
	20G-03-11310	HOSE	1	1001-1174
26	206-03-43340	CLIP	2	1001-

PW150-1 S/N 1001-UP
RADIATOR MOUNT AND PIPING

Item	Part No.	Part Name	Qty	Serial No.
27	20G-03-11210	PLATE	1	1001-
28	01010-51025	BOLT	3	1001-
29	01602-21030	WASHER,SPRING	3	1001-

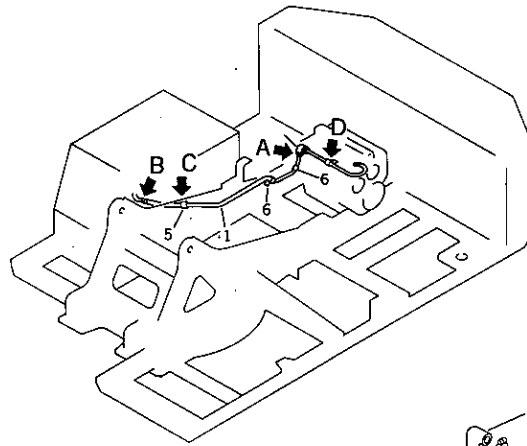

A 詳 図
Detail A

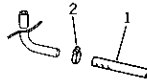

B 詳 図
Detail B

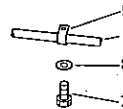

C 詳 図
Detail C

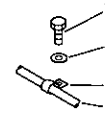

D 詳 図
Detail D

PW150-1 S/N 1001-UP
 FUEL PIPING

Item	Part No.	Part Name	Qty	Serial No.
1	20G-04-11110	HOSE,FUEL	1	1001-
2	07281-00197	CLAMP	2	1001-
3	205-62-53780	COVER	1	1001-
4	08034-00519	BAND	2	1001-
5	08036-01814	CLIP	1	1001-
6	111-04-33200	CLIP ASS'Y	3	1001-
7	01010-51016	BOLT	4	1001-
8	01643-31032	WASHER	4	1001-

PW150-1 S/N 1001-UP
 @@08496@

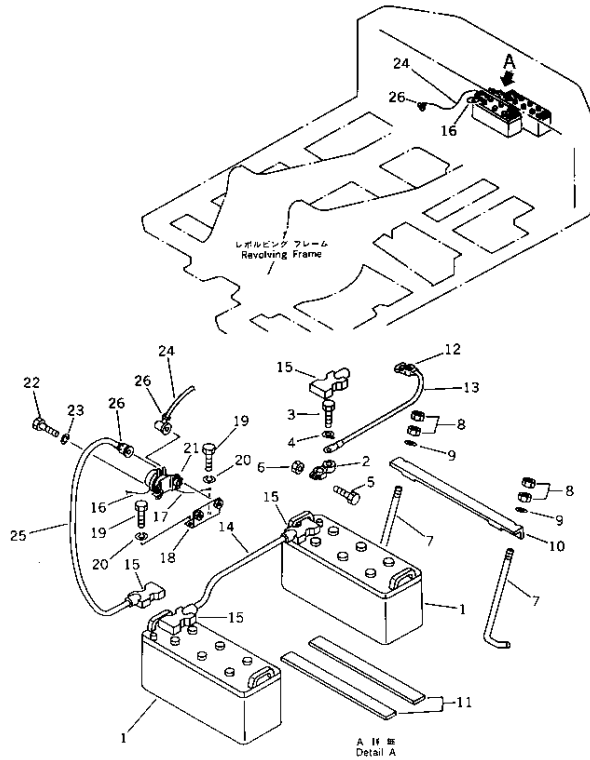

Ref. 1401

Page 030080

PW150-1 S/N 1001-UP
 BATTERY(#1001-1117)

Item	Part No.	Part Name	Qty	Serial No.
1	08000-02212	BATTERY (115F51)	2	1001-1117
2	08000-00000	TERMINAL, (+)	2	1001-@
	08000-00001	TERMINAL, (-)	2	1001-@
3	01050-51018	・ BOLT	1	1001-@
4	01640-21016	・ WASHER	1	1001-@
5	01010-50830	・ BOLT	1	1001-@
6	01580-00806	・ NUT	1	1001-@
7	20G-06-11130	ROD	4	1001-1117
8	01580-11008	NUT	8	1001-@
9	01643-31032	WASHER	4	1001-@
10	20G-06-11120	HOLDER	2	1001-1117
11	08007-03549	CUSHION	4	1001-1117
12	08038-22009	CAP	1	1001-1117
13	08028-12035	CABLE	1	1001-1117
14	08028-12025	CABLE	1	1001-1117
15	08038-22009	CAP	4	1001-@
16	20G-06-14381	WIRE	1	1001-1117
17	20G-06-14440	WIRE	1	1001-@
18	20G-06-11110	BRACKET	1	1001-@
19	01010-50816	BOLT	2	1001-@
20	01602-20825	WASHER,SPRING	2	1001-@
21	22W-06-13220	SWITCH,BATTERY	1	1001-@
22	01010-50830	BOLT	2	1001-@
23	01602-20825	WASHER,SPRING	2	1001-@
24	20G-06-14110	WIRE	1	1001-1117
25	6130-81-9910	PLATE, CAUTION	1	1001-1117
26	08038-04030	CAP	3	1001-@

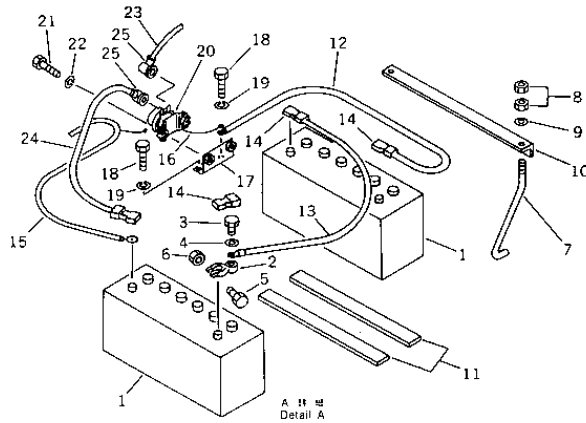
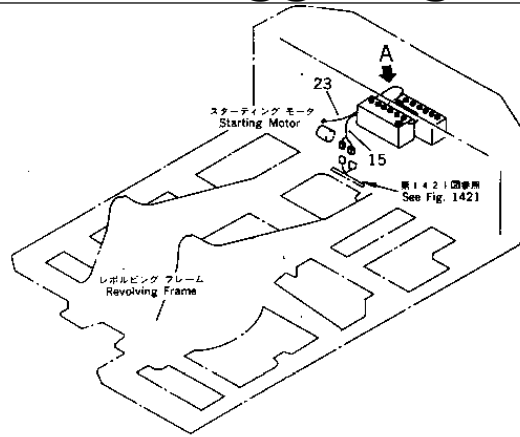

PW150-1 S/N 1001-UP
BATTERY(#1118-)

Item	Part No.	Part Name	Qty	Serial No.
1	08000-32212	BATTERY (115E41R)	2	1118-
2	08000-00000	TERMINAL, (+)	2	1001-
	08000-00001	TERMINAL, (-)	2	1001-
3	01050-51018	・ BOLT	1	1001-
4	01640-21016	・ WASHER	1	1001-
5	01010-50830	・ BOLT	1	1001-
6	01580-00806	・ NUT	1	1001-
7	120-06-31151	BOLT	4	1118-
8	01580-11008	NUT	8	1001-
9	01643-31032	WASHER	4	1001-
10	20G-06-11140	HOLDER	2	1118-
11	08007-03538	CUSHION	4	1118-
12	20G-06-14110	WIRE	1	1118-
13	08028-12045	CABLE	1	1118-
14	08038-22009	CAP	4	1001-
15	20G-06-14382	WIRE	1	1118-
16	20G-06-14440	WIRE	1	1001-
17	20G-06-11110	BRACKET	1	1001-
18	01010-50816	BOLT	2	1001-
19	01602-20825	WASHER,SPRING	2	1001-
20	22W-06-13220	SWITCH,BATTERY	1	1001-
21	01010-50830	BOLT	2	1001-
22	01602-20825	WASHER,SPRING	2	1001-
23	08028-12065	CABLE	1	1118-
24	08028-12035	CABLE	1	1118-
25	08038-04030	CAP	3	1001-

PW150-1 S/N 1001-UP
 @@Q62880

FIG.1403

バッテリー (寒冷地仕様)
 BATTERY (COLD TERRAIN SPEC.)

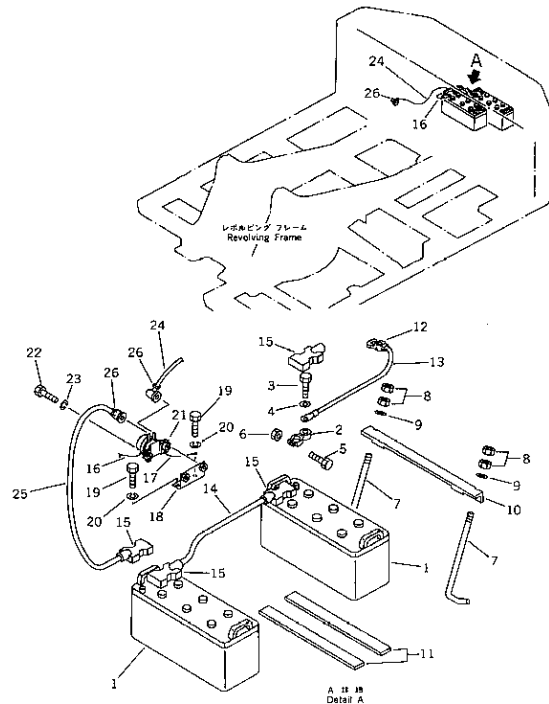

Ref. 1403

Page 030100

PW150-1 S/N 1001-UP
 BATTERY (COLD TERRAIN SPEC.)

Item	Part No.	Part Name	Qty	Serial No.
1	08000-42215	BATTERY (145F51)	2	1001-
2	08000-00000	TERMINAL, (+)	2	1001-
	08000-00001	TERMINAL, (-)	2	1001-
3	01050-51018	・ BOLT	1	1001-
4	01640-21016	・ WASHER	1	1001-
5	01010-50830	・ BOLT	1	1001-
6	01580-00806	・ NUT	1	1001-
7	20G-06-11130	ROD	4	1001-
8	01580-11008	NUT	8	1001-
9	01643-31032	WASHER	4	1001-
10	20G-06-11120	HOLDER	2	1001-
11	08007-03549	CUSHION	4	1001-
12	08038-02009	CAP	1	1001-1117
13	08028-12035	CABLE	1	1001-
14	08028-12025	CABLE	1	1001-
15	08038-22009	CAP	4	1001-
16	20G-06-14382	WIRE	1	1118-
	20G-06-14381	WIRE	1	1001-1117
17	20G-06-14440	WIRE	1	1001-
18	20G-06-11110	BRACKET	1	1001-
19	01010-50816	BOLT	2	1001-
20	01602-20825	WASHER,SPRING	2	1001-
21	22W-06-13220	SWITCH,BATTERY	1	1001-
22	01010-50830	BOLT	2	1001-
23	01602-20825	WASHER,SPRING	2	1001-
24	08028-12065	CABLE	1	1118-
	20G-06-14110	WIRE	1	1001-1117
25	08028-12035	CABLE	1	1118-
	08028-12065	CABLE	1	1001-1117

PW150-1 S/N 1001-UP
BATTERY (COLD TERRAIN SPEC.)

Item	Part No.	Part Name	Qty	Serial No.
26	08038-04030	CAP	3	1001-
27	6130-81-9910	PLATE, CAUTION,(NOT SHOWN)	1	1001-

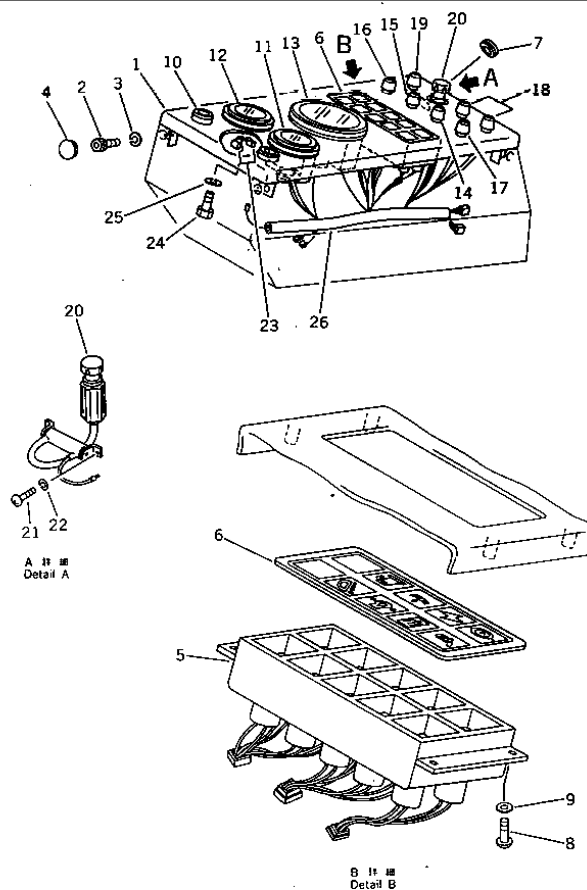

**PW150-1 S/N 1001-UP
INSTRUMENT PANEL**

Item	Part No.	Part Name	Qty	Serial No.
1	20G-06-12111	PANEL	1	1001-
2	01252-40612	BOLT	4	1001-
3	01602-20619	WASHER,SPRING	4	1001-
4	7816-21-1190	WASHER	3	1001-
5	20G-06-12170	BRACKET	1	1001-
6	20G-06-12121	PLATE	1	1001-
7	09415-01008	CAP	1	1001-
8	01220-40412	SCREW	4	1001-
9	01601-20410	WASHER,SPRING	4	1001-
10	22W-06-13270	LAMP	2	1001-
11	20D-68-12630	GAUGE,AIR PRESSURE	1	1001-
12	208-06-11280	GAUGE,WATER TEMPERATURE	1	1001-
13	20B-06-21210	TACHOMETER	1	1001-
14	205-06-71321	SWITCH,HEATER	1	1001-
15	205-06-71331	SWITCH,LAMP	1	1001-
16	205-06-71690	SWITCH ASS'Y,WIPER	1	1001-
17	20G-06-12330	SWITCH,WORK, PARKING	1	1001-
18	20G-06-12430	SWITCH,OUTRIGGER	2	1001-
19	20G-06-12480	SWITCH,HAZARD	1	1001-
20	195-822-6151	LIGHTER	1	1001-
21	01220-40408	SCREW	2	1001-
22	01601-20410	WASHER,SPRING	2	1001-
23	205-06-51290	CONDENSER	2	1001-
24	01010-50816	BOLT	1	1001-
25	01602-20825	WASHER,SPRING	1	1001-
26	20G-06-14272	WIRE	1	1001-
	22W-06-13590	· DIODE	1	1001-

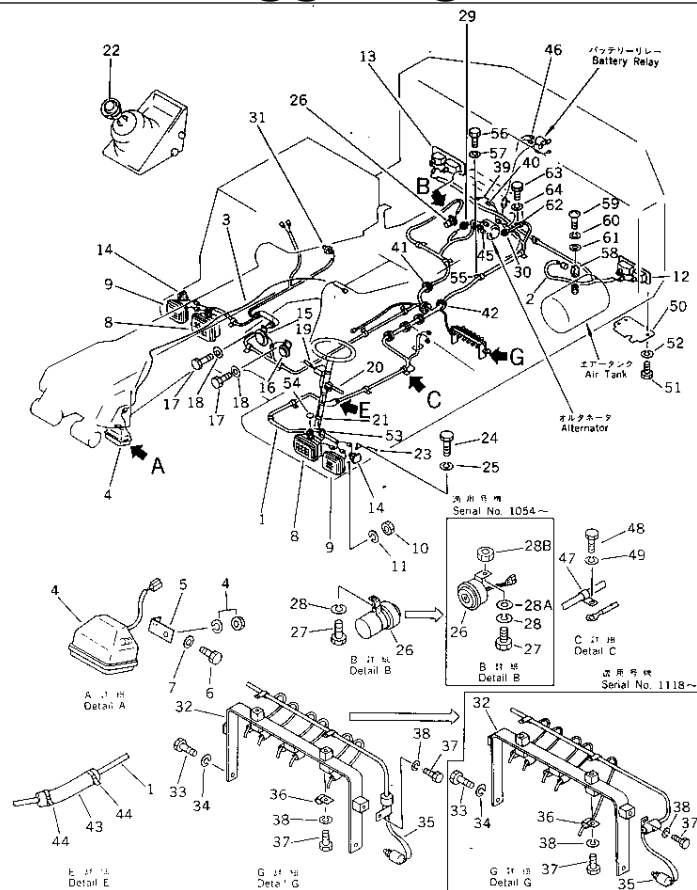

Ref. 1421

Page 030120

PW150-1 S/N 1001-UP
ELECTRICAL SYSTEM (1/2)

Item	Part No.	Part Name	Qty	Serial No.
1	20G-06-14225	WIRING	1	1144-
	20G-06-14224	WIRING	1	1001-1143
2	20G-06-14214	HARNESS	1	1054-
	20G-06-14213	HARNESS	1	1001-1053
	22W-06-13590	・ DIODE	1	1054-
	22W-06-13430	・ DIODE	1	1001-1053
3	20G-06-14252	WIRE	1	1001-
4	22W-06-12381	LAMP ASS'Y	1	1001-
	22W-06-12170	・ BULB, 24V	1	1001-
5	20G-06-13320	BRACKET	1	1001-
6	01010-51630	BOLT	1	1001-
7	01643-31645	WASHER	1	1001-
8	20G-06-13350	LAMP	2	-
	□20G-06-13150	LAMP	2	1001-
	20G-06-13360	・ BULB, 50/60W	1	1001-
9	20G-06-13110	LAMP ASS'Y	2	1001-
	08104-12420	・ BULB, 25/10W	1	1001-
	1C13E110-0010	・ LENS	1	1001-
10	01580-10504	NUT	4	1001-
11	01601-20513	WASHER	4	1001-
12	20G-06-13210	LAMP ASS'Y	1	1001-
	08105-12420	・ BULB, 25W	1	1001-
	08104-12420	・ BULB, 25/10W	1	1001-
	1C14G037-1001	・ LENS	1	1001-
13	20G-06-13220	LAMP ASS'Y	1	1001-
	08105-12420	・ BULB, 25W	1	1001-
	08104-12420	・ BULB, 25/10W	1	1001-
	1C14G037-1001	・ LENS	1	1001-
14	20D-06-12430	LAMP ASS'Y	2	1001-

**PW150-1 S/N 1001-UP
ELECTRICAL SYSTEM (1/2)**

Item	Part No.	Part Name	Qty	Serial No.
14	08102-02403	· BULB, 3W	1	1001-
	1C15F080-1001	· LENS	1	1001-
15	08160-52410	HORN	1	1398-
	□205-06-64430	HORN	1	1001-1397
16	08160-52400	HORN	1	1001-
17	01010-50816	BOLT	4	1001-
18	01641-20812	WASHER	4	1001-
19	20G-06-12350	SWITCH ASS'Y	1	1001-
20	20G-06-12370	SWITCH	1	1001-
21	362-43-15360	BAND	4	1001-
22	203-06-42141	SWITCH,HORN	1	1464-
	□203-06-42140	SWITCH,HORN	1	1272-1463
	□205-06-71360	SWITCH	1	1001-1271
23	20G-06-14320	WIRE	1	1001-
24	01010-50812	BOLT	1	1001-
25	01602-20825	WASHER	1	1001-
26	175-06-51210	BUZZER,(FOR JAPAN)	1	1054-
	08165-22400	BUZZER,(FOR JAPAN)	1	1001-1053
27	01220-40616	SCREW	1	1054-
	01010-51016	BOLT	1	1001-1053
28	01602-20619	WASHER,SPRING	1	1054-
	01602-21030	WASHER	1	1001-1053
28A	01640-20610	WASHER	1	1054-
28B	01580-10605	NUT	1	1054-
29	08073-00505	SWITCH	1	1001-
30	08620-00000	SENSOR	1	1001-
31	08073-00503	SWITCH	1	1001-
32	20G-06-15142	PLATE	1	1118-
	20G-06-15141	PLATE	1	1001-1117
33	01010-51025	BOLT	2	1001-
34	01602-21030	WASHER	2	1001-
35	203-06-41661	SWITCH,SWING BRAKE PRESSURE	1	1118-
	□203-06-41660	SWITCH,SWING BRAKE PRESSURE	1	1001-1117
36	08036-01814	CLIP	7	1001-
37	01010-51016	BOLT	4	1001-
38	01602-21030	WASHER	4	1001-
39	08028-12065	CABLE	1	1001-
40	08038-04030	CAP	3	1001-
41	08037-03620	GROMMET	1	1001-
42	08037-05022	GROMMET	6	1001-
43	203-04-31230	COVER	2	1001-
44	08034-00519	BAND	4	1001-
45	08038-00518	CAP	3	1001-
46	(08038-04030)	CAP,(SEE FIG.1401)	2	1001-
47	21T-62-25740	CLIP	23	1001-
48	01010-51016	BOLT	23	1001-
49	01602-21030	WASHER,SPRING	23	1001-
50	20G-06-13270	COVER,REAR LAMP	2	1001-
51	01010-50610	BOLT	6	1001-
52	01602-20619	WASHER,SPRING	6	1001-
53	08034-00310	BAND	2	1001-
54	09415-02520	CAP	1	1001-
55	08036-21814	CLIP	4	1001-
56	01010-51016	BOLT	4	1001-
57	01602-21030	WASHER,SPRING	4	1001-
58	283-06-17130	CLIP	1	1001-
59	01220-40616	SCREW	1	1001-
60	01602-20619	WASHER,SPRING	1	1001-
61	01641-20608	WASHER	1	1001-
62	08036-30814	CLIP	1	1001-
63	01010-51016	BOLT	1	1001-
64	01602-21030	WASHER,SPRING	1	1001-

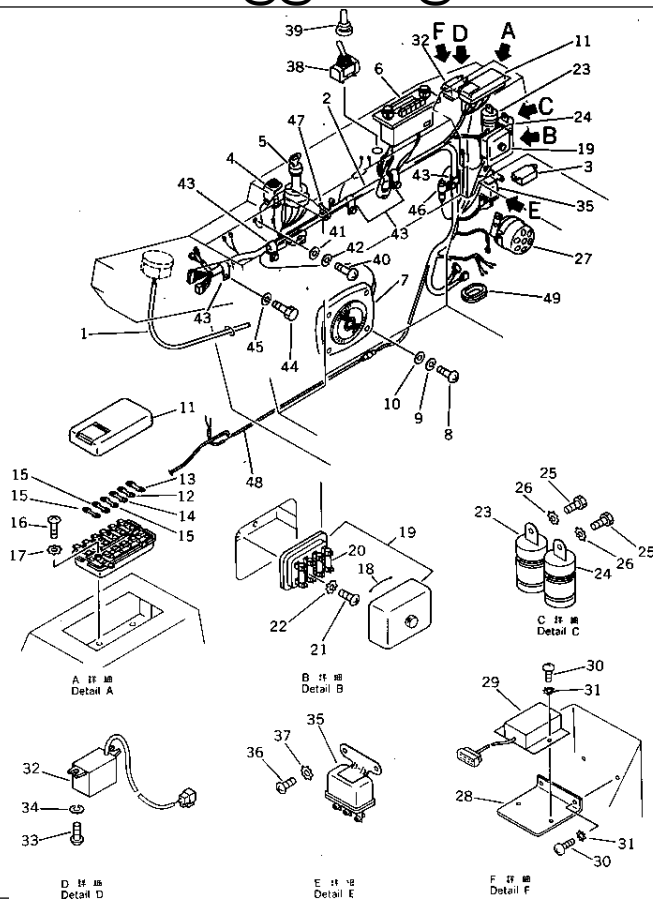

PW150-1 S/N 1001-UP
ELECTRICAL SYSTEM (2/2)

Item	Part No.	Part Name	Qty	Serial No.
1	20G-06-12410	TUBE,8200MM	1	1001-
2	20G-06-14263	HARNESS	1	1054-
	20G-06-14262	HARNESS	1	1001-1053
	22W-06-13590	· DIODE	2	1054-
	22W-06-13430	· DIODE	2	1001-1053
3	22W-44-11661	SWITCH,LOW PRESSURE	1	1001-
4	600-815-2371	SIGNAL,HEATER	1	1001-
5	08086-20000	SWITCH,STARTING	1	1001-
6	20G-06-15112	RADIO	1	1223-
	□20G-06-15110	RADIO	1	1001-1222
7	20G-06-15120	SPEAKER	1	1001-
8	01220-40420	SCREW	4	1001-
9	01601-20410	WASHER,SPRING	4	1001-
10	01641-20405	WASHER	4	1001-
11	175-06-35430	BOX,FUSE	1	1001-
12	175-06-35380	FUSE, 40A	1	1001-
13	175-06-35390	FUSE, 30A	1	1001-
14	175-06-35410	FUSE, 20A	1	1001-
15	175-06-35420	FUSE, 10A	3	1001-
16	01220-40616	SCREW	2	1001-
17	01611-06060	WASHER	2	1001-
18	20G-06-14460	WIRE	1	1001-
19	08043-04000	BOX	1	1001-
20	08040-02000	FUSE, 20A	1	1001-
21	01235-40516	SCREW	2	1001-
22	01611-05060	WASHER	2	1001-
23	08077-22400	FLASHER	1	1001-
24	20G-06-12510	FLASHER	1	1001-
25	01010-50612	BOLT	2	1001-

**PW150-1 S/N 1001-UP
ELECTRICAL SYSTEM (2/2)**

Item	Part No.	Part Name	Qty	Serial No.
26	01611-06060	WASHER	2	1001-
27	08166-02445	BUZZER	1	1001-
28	20G-06-12180	BRACKET	1	1001-
29	20G-06-15131	TIMER	1	1001-
30	01220-40610	SCREW	4	1001-
31	01611-06060	WASHER	4	1001-
32	22W-06-13330	BUZZER ASS'Y	1	1001-
33	01220-40410	SCREW	2	1001-
34	01601-20410	WASHER,SPRING	2	1001-
35	08163-02400	RELAY,HORN	1	1001-
36	01220-40608	SCREW	2	1001-
37	01611-06060	WASHER,LOCK	2	1001-
38	203-06-41570	SWITCH,SWING BRAKE RELEASE	1	1001-
39	203-06-41680	CAP,RED	1	1001-
40	01220-40610	SCREW	1	1001-
41	01641-20608	WASHER	1	1001-
42	01602-20619	WASHER,SPRING	1	1001-
43	08036-01814	CLIP	5	1001-
44	01010-51016	BOLT	5	1001-
45	01602-21030	WASHER,SPRING	5	1001-
46	08036-02514	CLIP	1	1001-
47	08034-00519	BAND	1	1001-
48	205-06-71532	WIRE	1	1001-
49	176-911-4160	GROMMET	1	1001-

PW150-1 S/N 1001-UP
TRAVEL AND TRANSMISSION

Item	Part Name	Qty
10	TRAVEL MOTOR (1/2)	1
20	TRAVEL MOTOR (2/2)	1
30	TRAVEL MOTOR BRAKE VALVE	1
40	SWIVEL JOINT	1
50	HYDRAULIC PIPING (1/3) (TANK TO PUMP TO VALVE)	1
60	HYDRAULIC PIPING (2/3) (VALVE TO OIL COOLER)(#1001-1188)	1
70	HYDRAULIC PIPING (2/3) (VALVE TO OIL COLLER)(#1189-)	1
80	HYDRAULIC PIPING (3/3) (PUMP TO FILTER TO SWIVEL JOINT)	1
90	TRAVEL MOTOR PIPING (SWIVEL JOINT TO MOTOR)	1
100	DRAIN PIPING (1/2)	1
110	DRAIN PIPING (2/2)	1
120	SUSPENSION PIPING	1
130	SUSPENSION LOCK CYLINDER	1
140	SUSPENSION LOCK VALVE	1
150	TRANSMISSION (1/3)	1
160	TRANSMISSION (2/3)	1
170	TRANSMISSION (3/3)	1

PW150-1 S/N 1001-UP
 @@01039@

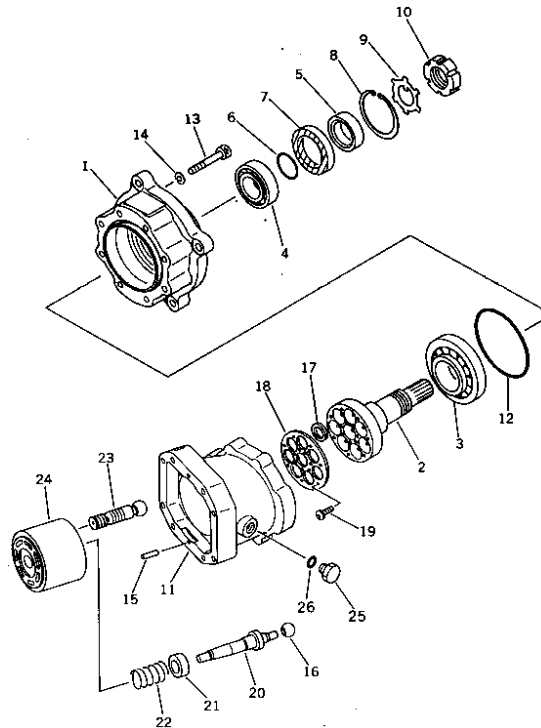

Ref. 2001

Page 060010

PW150-1 S/N 1001-UP
 TRAVEL MOTOR (1/2)

Item	Part No.	Part Name	Qty	Serial No.
	706-86-00201	TRAVEL MOTOR ASS'Y,(KMV105DT) THIS ASSEMBLY CONSISTS OF ALL PARTS SHOWN IN FIGS.2001 TO 2011.	1	1001-
	706-86-40103	· MOTOR ASS'Y THESE ASSEMBLIES CONSIST OF ALL PARTS SHOWN IN FIGS.2001 AND 2002.	1	1160-
	<input type="checkbox"/> 706-86-40102	· MOTOR ASS'Y THESE ASSEMBLIES CONSIST OF ALL PARTS SHOWN IN FIGS.2001 AND 2002.	1	1118-1159
	<input type="checkbox"/> 706-86-40101	· MOTOR ASS'Y THESE ASSEMBLIES CONSIST OF ALL PARTS SHOWN IN FIGS.2001 AND 2002.	1	1001-1117
1	(★706-76-40941)	· · COVER,FRONT	1	1001-
2	(★706-86-41860)	· · SHAFT,DRIVE	1	1001-
3	(★706-76-40350)	· · BEARING	1	1001-
4	(★706-76-40890)	· · BEARING	1	1001-
5	(★706-76-40910)	· · RING	1	1001-
6	(★07000-03045)	· · O-RING	1	1001-
7	(★706-76-40920)	· · SEAL,OIL	1	1001-
8	(★04065-09030)	· · RING,SNAP	1	1001-
9	(★01658-24523)	· · WASHER	1	1001-
10	(★01530-04512)	· · NUT,LOCK	1	1001-
11	(★706-86-41811)	· · CASE,PUMP	1	1001-
12	(★07000-02140)	· · O-RING	1	1001-
13	(★706-76-40330)	· · BOLT	8	1001-
14	(★01602-21236)	· · WASHER,SPRING	8	1001-
15	(★04020-00820)	· · PIN,DOWEL	2	1001-
16	(★706-76-41220)	· · BALL,CENTER	1	1001-
17	(★706-76-40251)	· · HOLDER	8	1001-
18	(★706-76-40263)	· · RETAINER	1	1001-

**PW150-1 S/N 1001-UP
TRAVEL MOTOR (1/2)**

Item	Part No.	Part Name	Qty	Serial No.
19	(★706-75-41271)	· · SCREW	14	1001-
20	(★706-86-41080)	· · SHAFT,CENTER	1	1001-
21	(★706-86-41130)	· · RING,CENTER	1	1001-
22	(★706-86-40110)	· · SPRING	1	1001-
23	(★706-76-40163)	· · PISTON ASS'Y	1	1001-
24	(★706-86-41090)	· · BLOCK,CYLINDER	1	1001-
25	07040-12012	· PLUG	1	1001-
26	07002-02034	· O-RING	1	1001-

PW150-1 S/N 1001-UP
 @@01040@

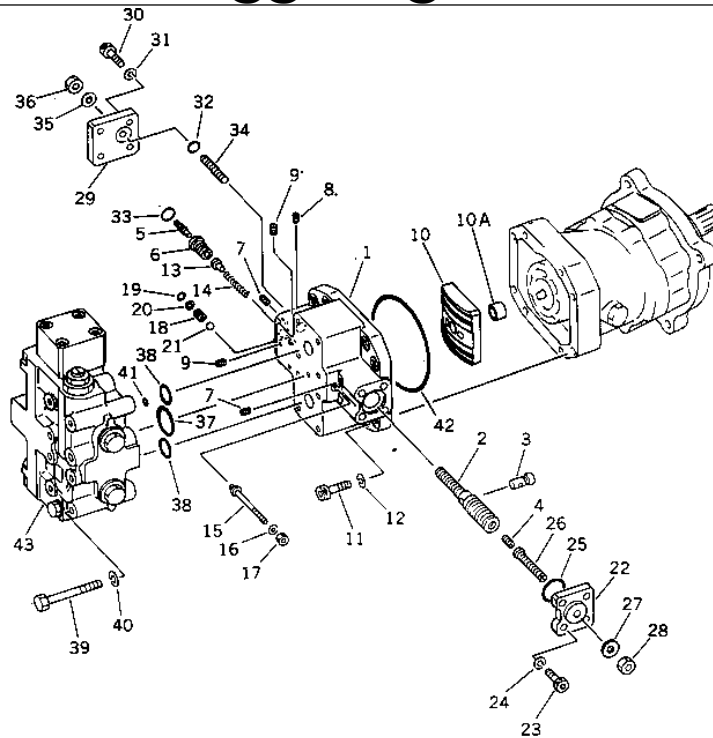

Ref. 2002

Page 060020

PW150-1 S/N 1001-UP
 TRAVEL MOTOR (2/2)

Item	Part No.	Part Name	Qty	Serial No.
	(706-86-00201)	TRAVEL MOTOR ASS'Y,(KMV105DT)	1	1001-
		THIS ASSEMBLY CONSISTS OF ALL PARTS SHOWN IN FIGS.2001 TO 2011.		
	(706-86-40103)	· MOTOR ASS'Y	1	1160-
		THESE ASSEMBLIES CONSIST OF ALL PARTS SHOWN IN FIGS.2001 AND 2002.		
	(□706-86-40102)	· MOTOR ASS'Y	1	1118-1159
		THESE ASSEMBLIES CONSIST OF ALL PARTS SHOWN IN FIGS.2001 AND 2002.		
	(□706-86-40101)	· MOTOR ASS'Y	1	1001-1117
		THESE ASSEMBLIES CONSIST OF ALL PARTS SHOWN IN FIGS.2001 AND 2002.		
	(★706-86-00020)	· · · END COVER ASS'Y	1	1001-
	(★706-86-00120)	· · · · END COVER ASS'Y	1	1001-
1	☆	· · · · · COVER,END	1	1118-
	☆	· · · · · COVER,END	1	1001-1117
2	☆	· · · · · PISTON	1	1160-
	☆	· · · · · PISTON	1	1001-1159
3	☆	· · · · · PIN	1	1160-
	☆	· · · · · PIN	1	1001-1159
4	☆	· · · · · SCREW	1	1160-
	☆	· · · · · SCREW	1	1001-1159
5	☆	· · · · · SPOOL	1	1001-
6	☆	· · · · · SLEEVE	1	1118-
	☆	· · · · · SLEEVE	1	1001-1117
7	☆	· · · · · PLUG	2	1001-
8	(★706-86-51180)	· · · · · PLUG	1	1001-
9	(★706-86-51170)	· · · · · PLUG	2	1001-
10	(★706-86-41841)	· · · VALVE PLATE	1	1001-
10A	(★706-86-41070)	· · · BUSHING	1	1118-

Thank you so much for reading.
Please click the “Buy Now!”
button below to download the
complete manual.



After you pay.

You can download the most
perfect and complete manual in
the world immediately.

Our support email:

ebooklibonline@outlook.com