

PW400MH-6 MATERIAL HANDLER S/N A84210-UP
PW400MH-6 MATERIAL HANDLER S/N A84210-UP

DESCRIPTION

ENGINE - 6D125E-2
ENGINE RELATED PARTS
COOLING SYSTEM
FUEL TANK AND RELATED PARTS
ELECTRICAL SYSTEM
HYDRAULIC SYSTEM
MAIN/REVOLVING FRAME AND RELATED PARTS
OPERATOR'S COMPARTMENT AND CONTROL SYSTEM
GUARD
SWING CIRCLE AND RELATED PARTS
MARKS AND PLATES
ACCESSORY
SERVICE KIT AND COMPONENT PARTS

PW400MH-6 MATERIAL HANDLER S/N A84210-UP

ENGINE

DESCRIPTION

CYLINDER HEAD
VALVE COVERS
VALVE COVER
OIL FILL
AFTERCOOLER AND AIR INTAKE MANIFOLD
AIR INTAKE MANIFOLD
AFTERCOOLER PLUMBING
AIR CLEANER
EXHAUST MANIFOLD
TURBOCHARGER PLUMBING
TURBOCHARGER
TURBOCHARGER OIL PIPING
TURBOCHARGER
MUFFLER
MUFFLER
COOLANT TEMPERATURE SENSOR
CYLINDER BLOCK - MAIN ASSEMBLY
CYLINDER BLOCK
CYLINDER BLOCK - BLIND COVER AND PLUG
FRONT COVER MOUNTING
IDLER GEAR
IDLER GEAR
CAM FOLLOWER COVER
CYLINDER BLOCK - SENSORS
FRONT GEAR COVER
OIL PAN AND SUCTION TUBE
OIL LEVEL GAUGE
OIL PAN
FLYWHEEL HOUSING
OIL LEVEL GAUGE
FLYWHEEL
FLYWHEEL
CRANKSHAFT
VIBRATION DAMPER
PISTON AND CONNECTING ROD
CRANK PULLEY
CRANKSHAFT PULLEY - HARDENED
ROCKER LEVER
CAMSHAFT
CAMSHAFT
TACHOMETER DRIVE - DRIVE GEAR
LUBRICATING OIL PUMP
OIL FILTER
OIL FILTER PLUMBING
OIL FILTER
OIL ADAPTER
OIL BYPASS FILTER
LUBRICATING OIL COOLER
LUBRICATING OIL COOLER
OIL COOLER MOUNTING PARTS
WATER DRAIN VALVE
FUEL INJECTION PUMP
FUEL INJECTION PUMP PIPING
FUEL INJECTION PUMP DRIVE
FUEL DRAIN LINE MOUNTING
FUEL-WATER SEPARATOR PLUMBING
FUEL PRE-FILTER
FUEL-WATER SEPARATOR
FUEL FILTER
FUEL FILTER
FUEL INJECTION PUMP
FUEL INJECTOR PLUMBING
INJECTION NOZZLE
FUEL INJECTOR
INJECTION NOZZLE - HOLDER ASSEMBLY
FUEL RETURN

PW400MH-6 MATERIAL HANDLER S/N A84210-UP

ENGINE

DESCRIPTION

WATER PUMP
WATER PUMP
AIR VENT
COOLING FAN
FAN PULLEY
FAN DRIVE
FAN PULLEY - 198MM DIAMETER
FAN PULLEY - 212MM DIAMETER
FAN PULLEY - 212MM DIAMETER, HARDENED
FAN DRIVE - FOR 198MM DIAMETER PULLEY
COOLING FAN - FOR 198MM DIAMETER PULLEY
COOLING FAN - FOR 212MM DIAMETER PULLEY
CORROSION RESISTOR
ALTERNATOR MOUNTING - (50A WITH NON-HARDENED PULLEY)
ALTERNATOR - (50A WITH NON-HARDENED PULLEY)
ALTERNATOR MOUNTING - FOR 35A, HARDENED PULLEY
ALTERNATOR MOUNTING - FOR 35A, HARDENED PULLEY
ALTERNATOR MOUNTING - FOR 50A, NON-HARDENED PULLEY
ALTERNATOR - 35A WITH NON-HARDENED PULLEY
ALTERNATOR - 35A WITH HARDENED PULLEY
ALTERNATOR - 50A WITH HARDENED PULLEY
STARTER MOTOR MOUNTING - (11KW)
STARTER MOTOR MOUNTING - 11KW
STARTER MOTOR - 11KW
STARTER MOTOR - 11KW
ENGINE WIRING HARNESS
ENGINE WIRING HARNESS
SAFETY GUARD - FUEL INJECTION PUMP
FUEL PUMP COVER
CYLINDER BLOCK GASKET KIT
CYLINDER HEAD GASKET KIT
WATER PUMP GASKET KIT
GASKET SETS
NAME AND CAUTION PLATE

FIG A1010-A3B7A

FIG. A1010-A3B7A CYLINDER HEAD

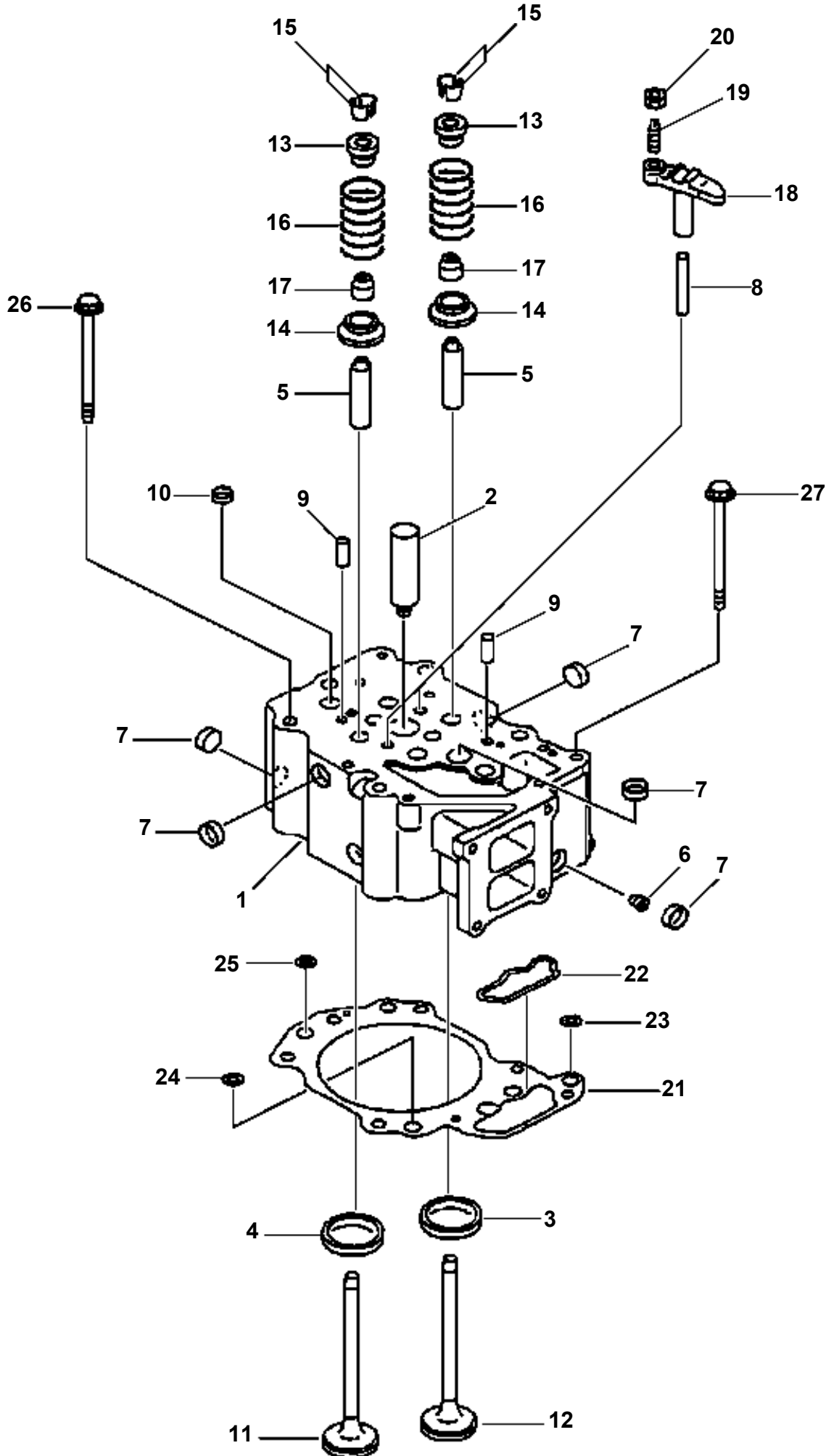

**PW400MH-6 MATERIAL HANDLER S/N A84210-UP
FIG. A1010-A3B7A CYLINDER HEAD**

ITEM NO.	PART NO.	DESCRIPTION	Q'TY
	6151-12-1101	CYLINDER HEAD ASSEMBLY	6
1	(NSS)	· HEAD, CYLINDER	1
2	6136-11-1130	· SLEEVE	1
3	6150-11-1320	· INSERT, EXHAUST VALVE	2
	6150-19-1320	· INSERT, EXHAUST VALVE (0.25MM OVERSIZE)	2
	6150-18-1320	· INSERT, EXHAUST VALVE (0.50MM OVERSIZE)	2
	6150-17-1320	· INSERT, EXHAUST VALVE (0.75MM OVERSIZE)	2
	6150-16-1320	· INSERT, EXHAUST VALVE (1.00MM OVERSIZE)	2
4	6151-11-1330	· INSERT, INTAKE VALVE	2
	6151-19-1330	· INSERT, INTAKE VALVE (0.25MM OVERSIZE)	2
	6151-18-1330	· INSERT, INTAKE VALVE (0.50MM OVERSIZE)	2
	6151-17-1330	· INSERT, INTAKE VALVE (0.75MM OVERSIZE)	2
	6151-16-1330	· INSERT, INTAKE VALVE (1.00MM OVERSIZE)	2
5	6150-12-1370	· GUIDE, VALVE	4
6	07043-70108	· PLUG	1
7	6162-13-1150	· PLUG	10
8	6150-11-1140	· GUIDE	2
9	04020-00820	· PIN, DOWEL	2
10	07046-41810	· PLUG	1
11	6150-42-4110	VALVE, INTAKE	12
12	6150-42-4210	VALVE, EXHAUST	12
13	6150-41-4510	SEAT, UPPER	24
14	6150-41-4430	SEAT, LOWER	24
15	6136-42-4520	COTTER, VALVE	48
16	6150-41-4450	SPRING	24
17	6150-41-4570	SEAL, VALVE STEM	24
	6150-42-5600	CROSSHEAD ASSEMBLY	12
18	6150-42-5610	· CROSSHEAD	1
19	6150-41-5620	· SCREW	1
20	6150-41-5630	· NUT	1
21	6151-12-1810	GASKET, CYLINDER HEAD	6
22	(NSS)	· GROMMET, OIL	1
23	(NSS)	· GROMMET, OIL	1
24	(NSS)	· GROMMET, WATER	4
25	(NSS)	· GROMMET, WATER	1
26	6150-11-1610	BOLT	36
27	01438-01020	BOLT	6

FIG A1110-A3A7

FIG. A1110-A3A7 VALVE COVERS

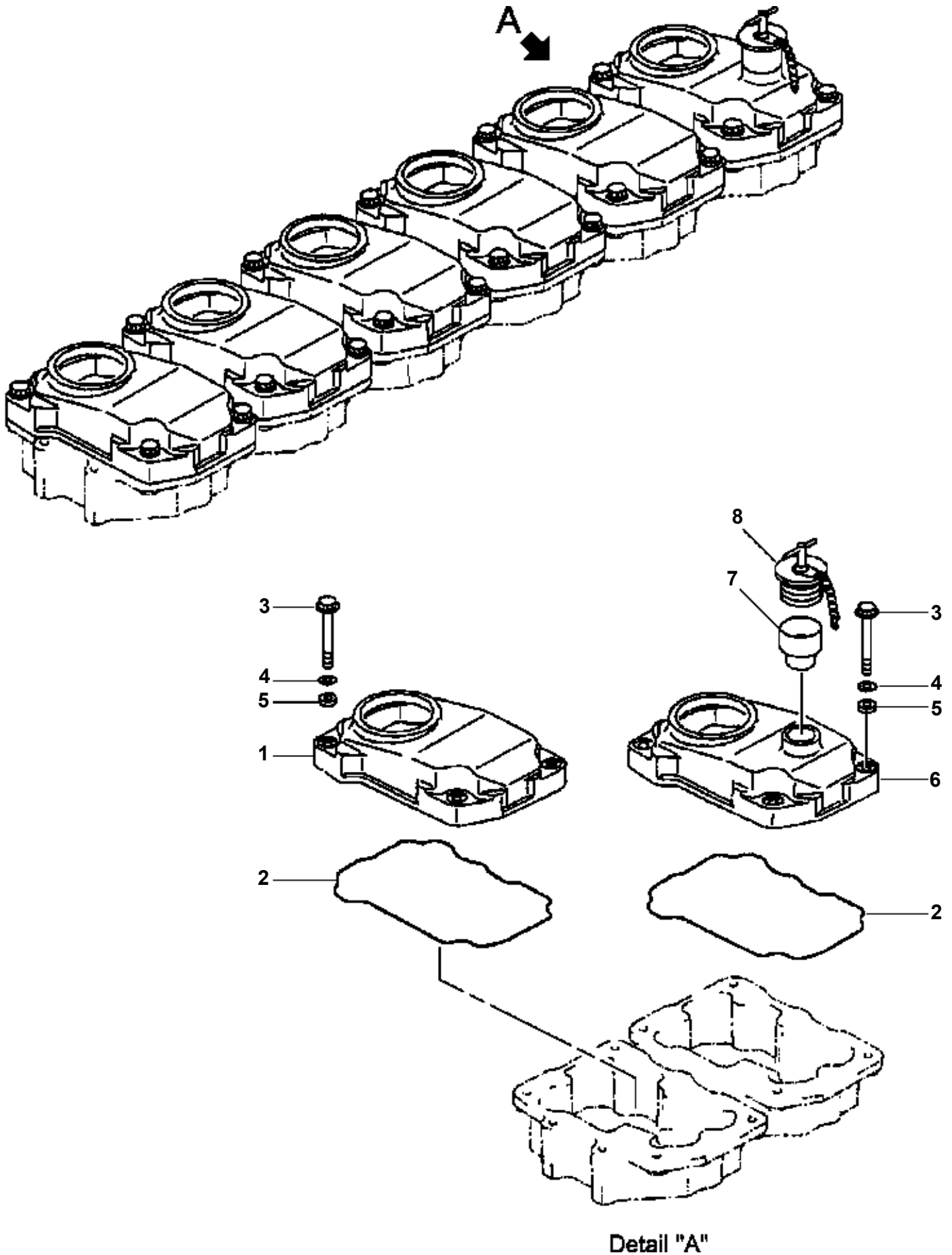

PW400MH-6 MATERIAL HANDLER S/N A84210-UP
FIG. A1110-A3A7 VALVE COVERS

ITEM NO.	PART NO.	DESCRIPTION	Q'TY
1	6150-11-8111	COVER, VALVE	5
2	6150-11-8810	GASKET	6
3	6150-81-9370	BOLT	24
4	01640-21016	WASHER	24
5	6150-11-8820	SPACER, RUBBER	24
6	6150-11-8151	COVER, VALVE	1
7	6150-21-6520	TUBE, OIL FILL	1
8	07025-00050	CAP, OIL FILL	1

FIG A1110-A3B9

FIG. A1110-A3B9 VALVE COVER

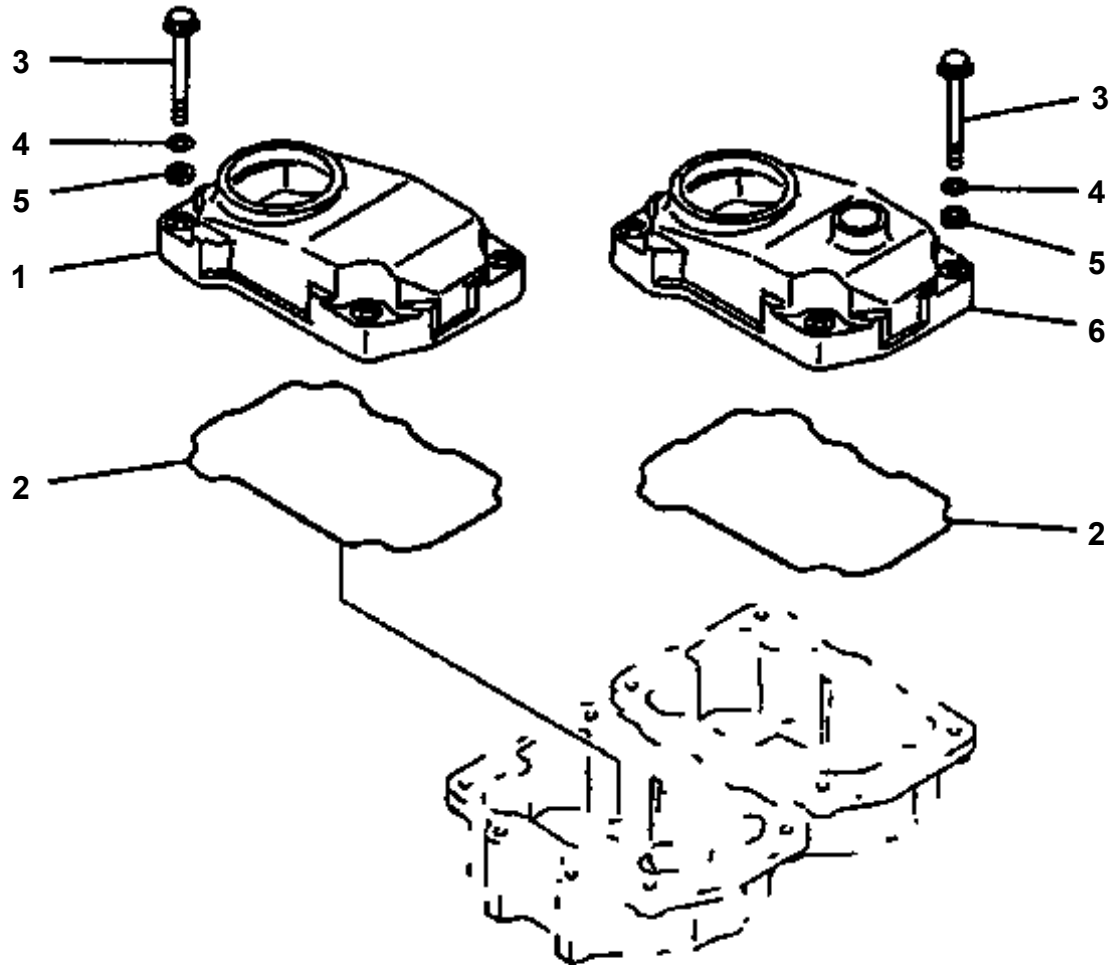
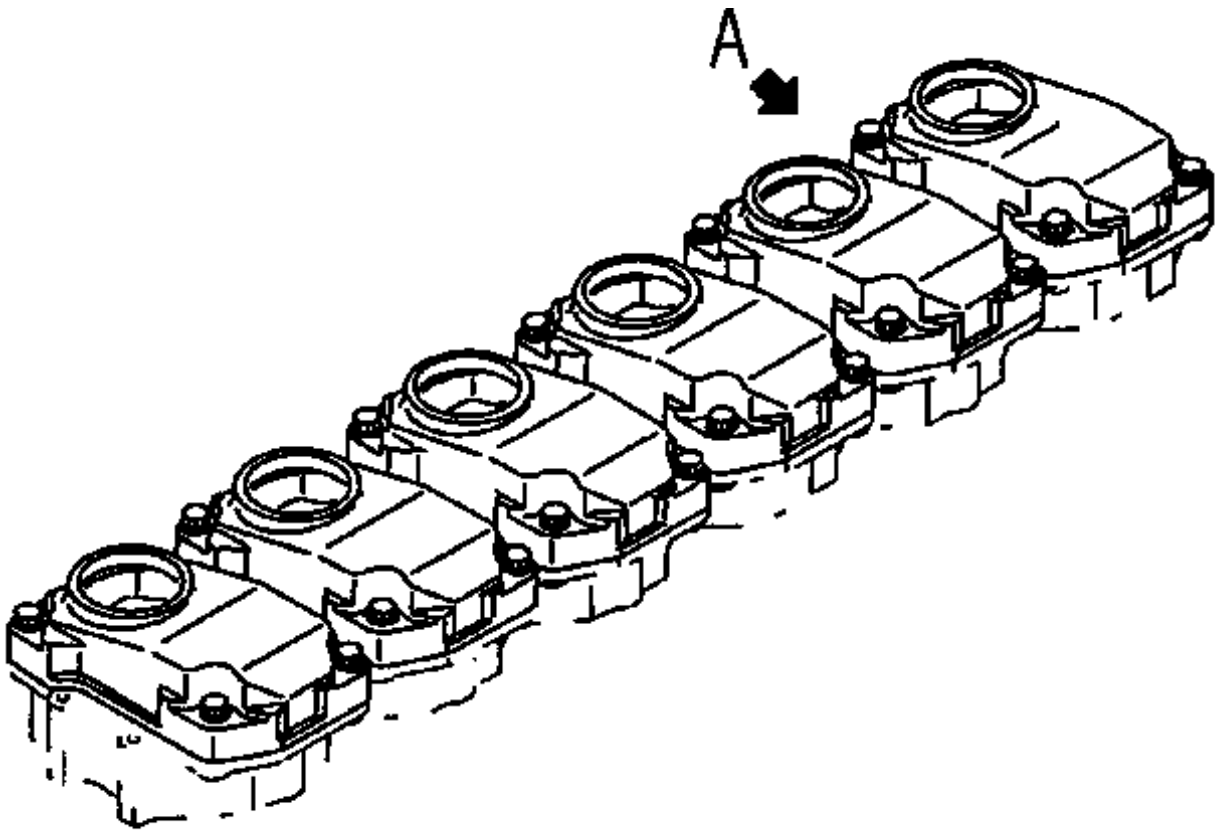

DETAIL A

**PW400MH-6 MATERIAL HANDLER S/N A84210-UP
FIG. A1110-A3B9 VALVE COVER**

ITEM NO.	PART NO.	DESCRIPTION	Q'TY	REF	SERIAL NO.
1	6150-11-8111	COVER, HEAD (NO. 1,2,3,4,5)	5		SN:A84210 ---
2	6150-11-8810	GASKET	6	F1	SN:A84210 ---
3	6150-81-9370	BOLT	24		SN:A84210 ---
4	01640-21016	WASHER	24		SN:A84210 ---
5	6150-11-8820	RUBBER	24	F1	SN:A84210 ---
6	6150-11-8151	COVER, HEAD (NO. 6)	1		SN:A84210 ---
		F1 THESE ITEMS ARE ALSO INCLUDED IN CYLINDER HEAD GASKET KIT. REFER TO FIG. A8123-A3A8.			

FIG A1111-A3A6

FIG. A1111-A3A6 OIL FILL

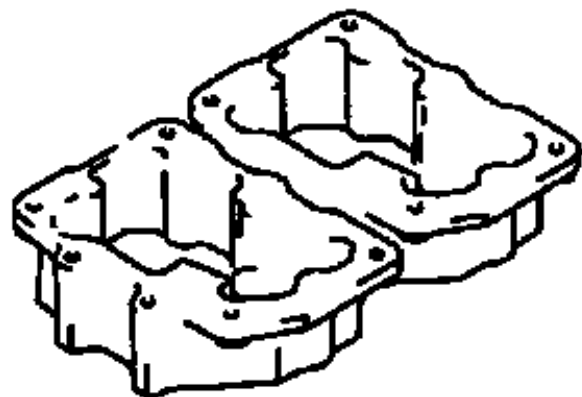
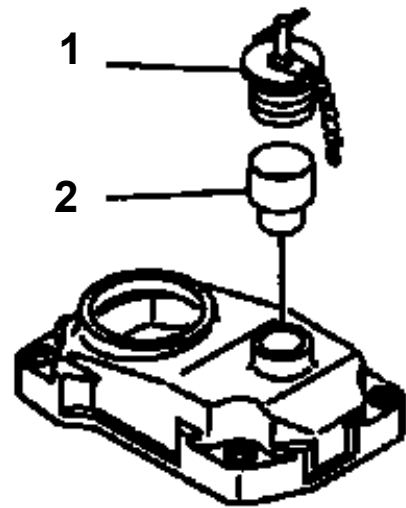
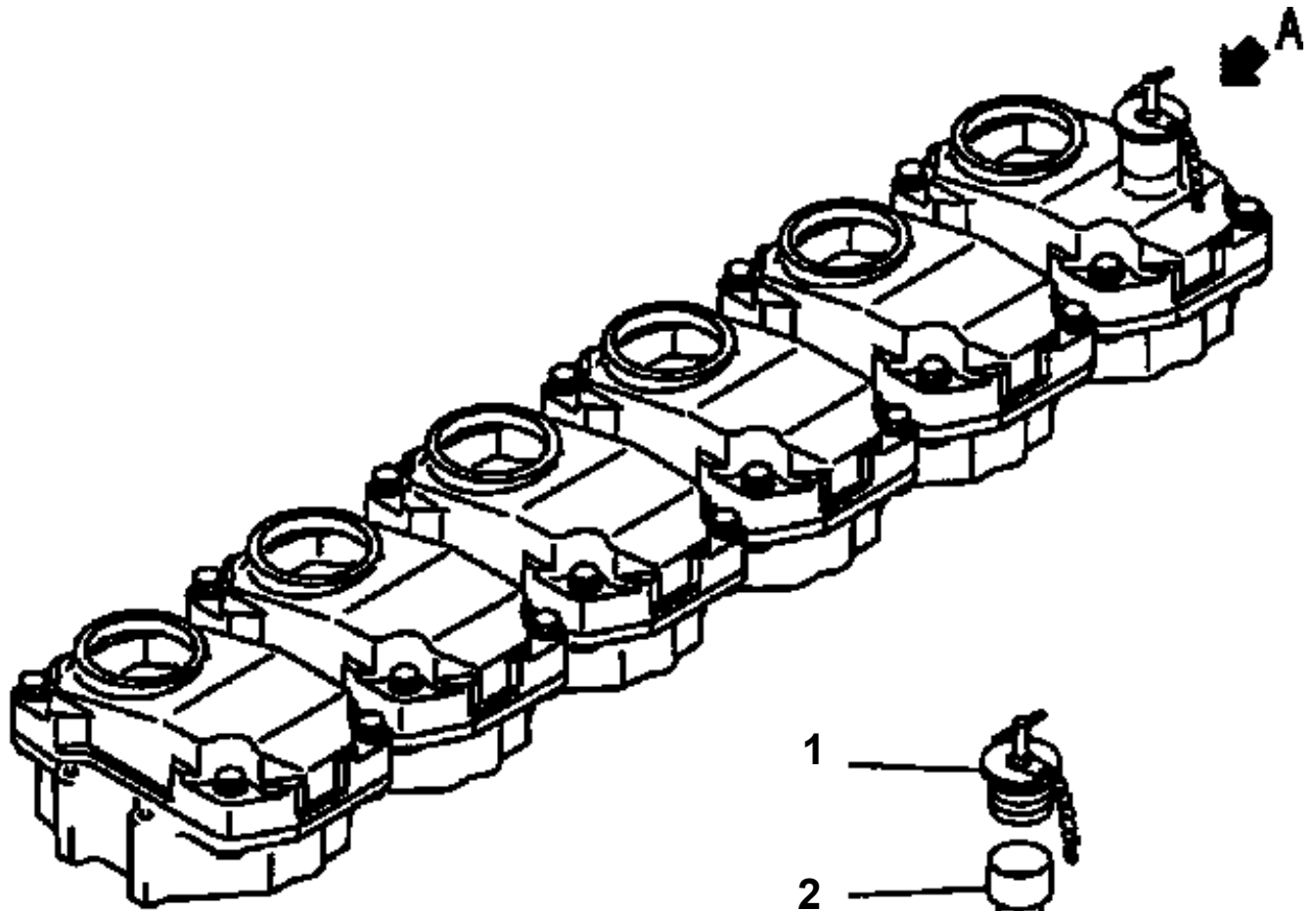

DETAIL A

**PW400MH-6 MATERIAL HANDLER S/N A84210-UP
FIG. A1111-A3A6 OIL FILL**

ITEM NO.	PART NO.	DESCRIPTION	Q'TY	SERIAL NO.
1	07025-00050	CAP	1	SN:A84210 ---
2	6150-21-6520	TUBE	1	SN:A84210 ---

FIG A1310-A3E6

FIG. A1310-A3E6 AFTERCOOLER AND AIR INTAKE MANIFOLD

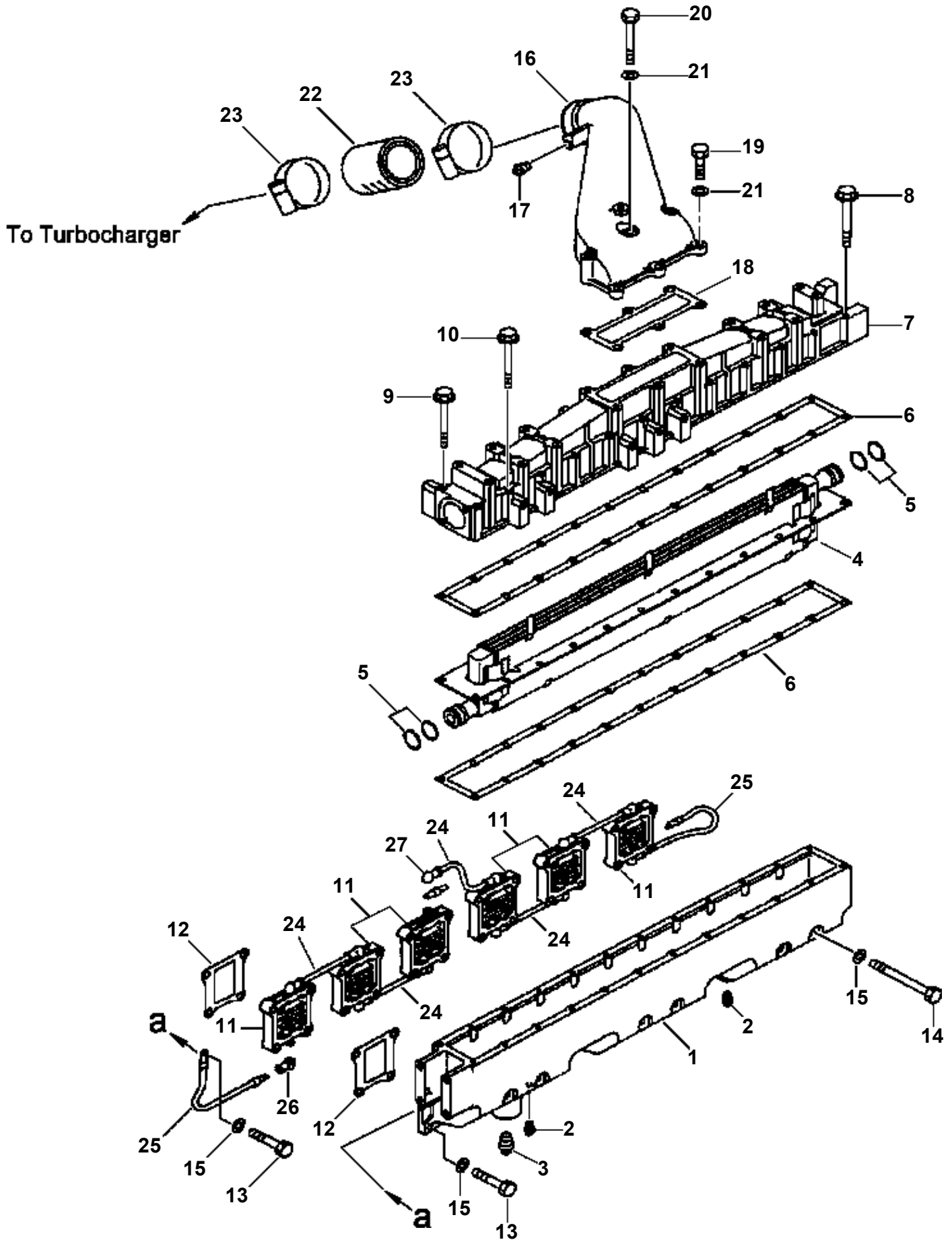

PW400MH-6 MATERIAL HANDLER S/N A84210-UP
FIG. A1310-A3E6 AFTERCOOLER AND AIR INTAKE MANIFOLD

ITEM NO.	PART NO.	DESCRIPTION	Q'TY
	6152-62-6101	AFTERCOOLER ASSEMBLY	1
1	6152-12-4110	· MANIFOLD, AIR INTAKE	1
2	07042-00108	· PLUG	2
3	07042-00415	· PLUG	1
4	6152-62-6111	· CORE, AFTERCOOLER	1
5	6222-61-6240	· ORING	4
6	6152-11-4731	· GASKET	1
7	6152-12-4210	· COVER	1
8	01435-00880	· BOLT	2
9	01435-00890	· BOLT	3
10	01435-00885	· BOLT	19
11	600-815-3820	HEATER, AIR INTAKE	6
12	6150-13-4810	GASKET	12
13	01010-81050	BOLT	18
14	01011-81055	BOLT	6
15	01640-21016	WASHER	24
16	6152-12-4360	CONNECTOR, AIR	1
17	07042-00108	PLUG	1
18	6152-11-4721	GASKET	1
19	01010-81035	BOLT	3
20	01010-81075	BOLT	3
21	01640-21016	WASHER	6
22	6151-11-4410	HOSE	1
23	07281-00909	CLAMP	2
24	6151-81-4450	WIRE, 160MM	5
25	6678-81-4340	WIRE, 170MM	2
26	08038-00519	CAP	11
27	6134-81-4910	CAP	1

FIG A1310-A3M9

FIG. A1310-A3M9 AIR INTAKE MANIFOLD

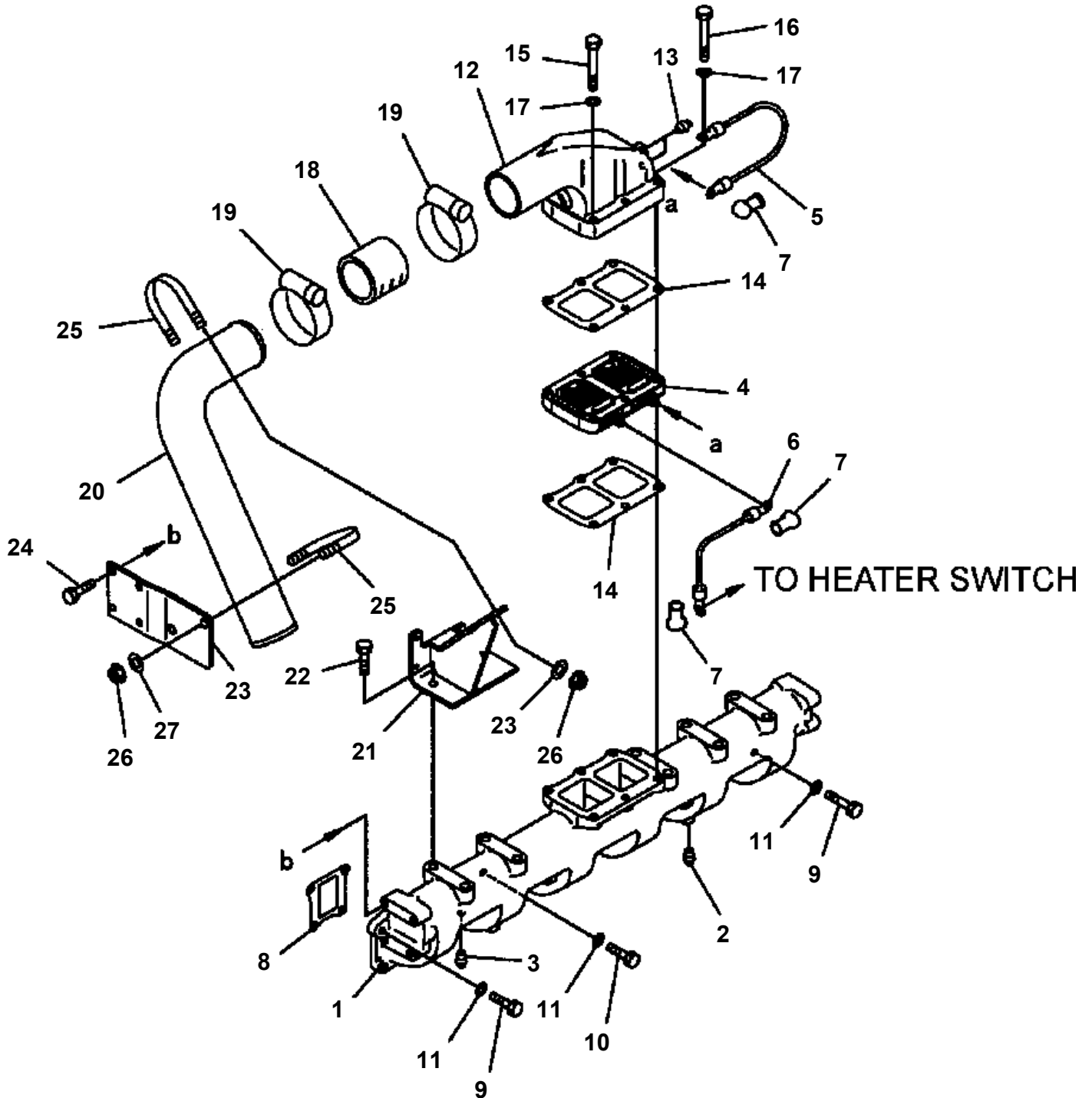

**PW400MH-6 MATERIAL HANDLER S/N A84210-UP
FIG. A1310-A3M9 AIR INTAKE MANIFOLD**

ITEM NO.	PART NO.	DESCRIPTION	Q'TY	REF	SERIAL NO.
1	6151-11-4910 (NSS)	INTAKE MANIFOLD · MANIFOLD	1		SN:A84210 ---
2	07042-00108	· PLUG	1		SN:A84210 ---
3	07042-00415	· PLUG	2		SN:A84210 ---
4	600-815-3811	HEATER	1		SN:A84210 ---
5	6212-82-4350	WIRE	1		SN:A84210 ---
6	6152-82-4150	WIRE	1		SN:A84210 ---
7	08038-00519	CAP	3		SN:A84210 ---
8	6150-13-4810	GASKET	6	F1	SN:A84210 ---
9	01010-81030	BOLT	12		SN:A84210 ---
10	01011-81010	BOLT	8		SN:A84210 ---
11	01640-21016	WASHER	20		SN:A84210 ---
12	6152-12-4341	CONNECTOR	1		SN:A84210 ---
13	07042-00108	PLUG	2		SN:A84210 ---
14	6150-11-4821	GASKET	2	F1	SN:A84210 ---
15	01010-81070	BOLT	5		SN:A84210 ---
16	01010-81075	BOLT	1		SN:A84210 ---
17	01640-21016	WASHER	7		SN:A84210 ---
18	6151-11-4410	HOSE	1		SN:A84210 ---
19	6152-12-4490	CLAMP	2		SN:A84210 ---
20	6152-12-4960	TUBE	1		SN:A84210 ---
21	6152-12-4990	BRACKET	1		SN:A84210 ---
22	01010-81025	BOLT	2		SN:A84210 ---
23	6152-12-4980	BRACKET	1		SN:A84210 ---
24	01010-81030	BOLT	4		SN:A84210 ---
25	07283-17663	CLIP	2		SN:A84210 ---
26	01597-01009	NUT	4		SN:A84210 ---
27	01643-31032	WASHER	4		SN:A84210 ---
<p align="center">F1 THESE ITEMS ARE ALSO INCLUDED IN CYLINDER HEAD GASKET KIT. REFER TO FIG. A8123-A3A8.</p>					

FIG A1310-B3E6

FIG. A1310-B3E6 AFTERCOOLER PLUMBING

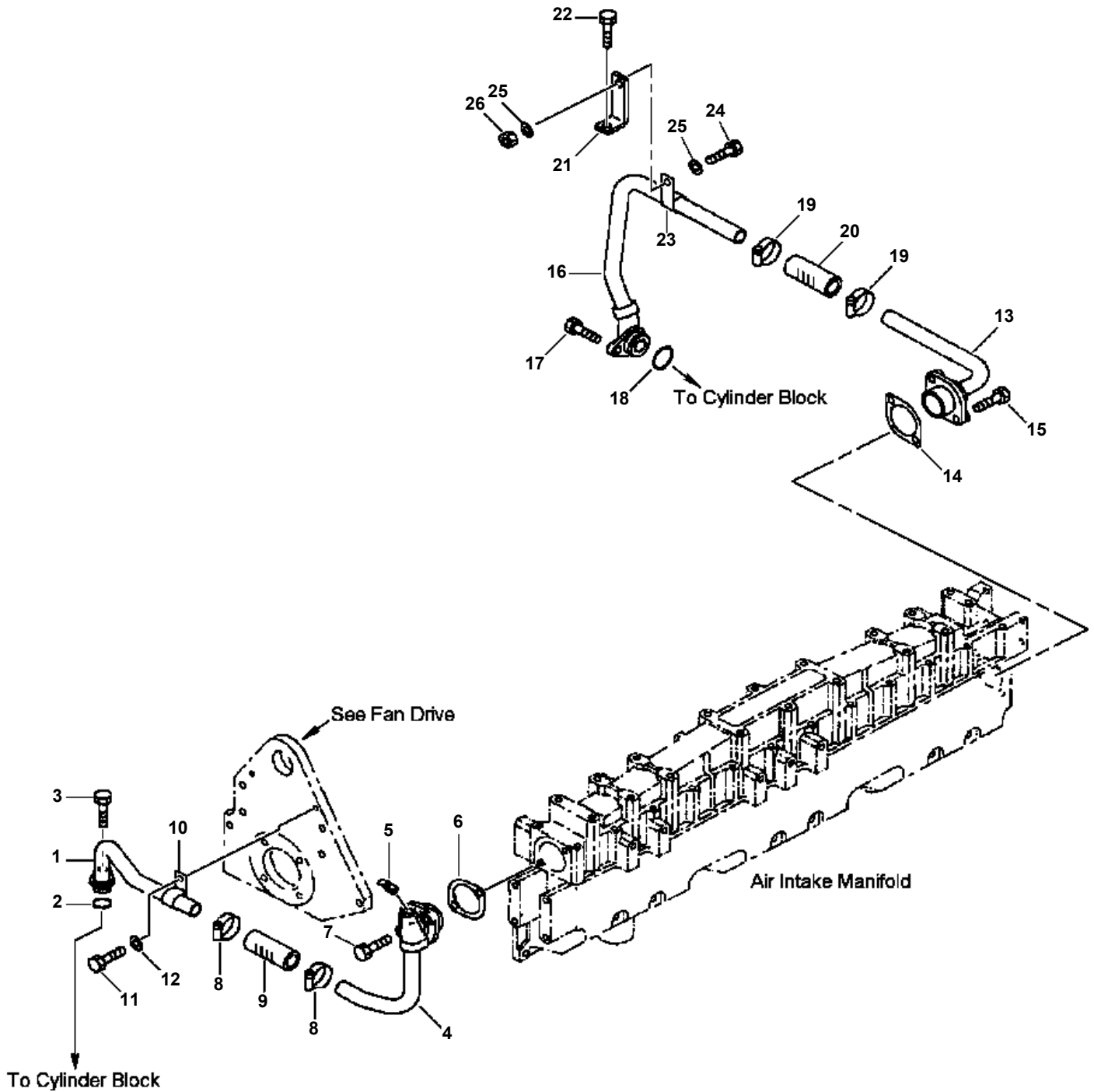

**PW400MH-6 MATERIAL HANDLER S/N A84210-UP
FIG. A1310-B3E6 AFTERCOOLER PLUMBING**

ITEM NO.	PART NO.	DESCRIPTION	Q'TY
1	6152-62-6410	TUBE	1
2	07000-02021	ORING	1
3	01010-81020	BOLT	1
4	6152-62-6420	TUBE	1
5	07062-00000	VALVE	1
6	6152-61-6721	GASKET	1
7	01010-81035	BOLT	2
8	07260-22008	HOSE	1
9	07281-00359	CLAMP	2
10	04434-52210	CLIP	1
11	01010-81016	BOLT	1
12	01640-21016	WASHER	1
13	6152-62-6520	TUBE	1
14	6152-61-6721	GASKET	1
15	01010-81035	BOLT	2
16	6152-62-6510	TUBE	1
17	01010-81025	BOLT	1
18	07000-A3030	ORING	1
19	07260-22008	HOSE	1
20	07281-00359	CLAMP	2
21	6136-21-5630	BRACKET	1
22	01010-81025	BOLT	1
23	04434-52210	CLIP	1
24	01010-81016	BOLT	1
25	01640-21016	WASHER	2
26	01580-11008	NUT	1

FIG A1410-A3G5

FIG. A1410-A3G5 AIR CLEANER

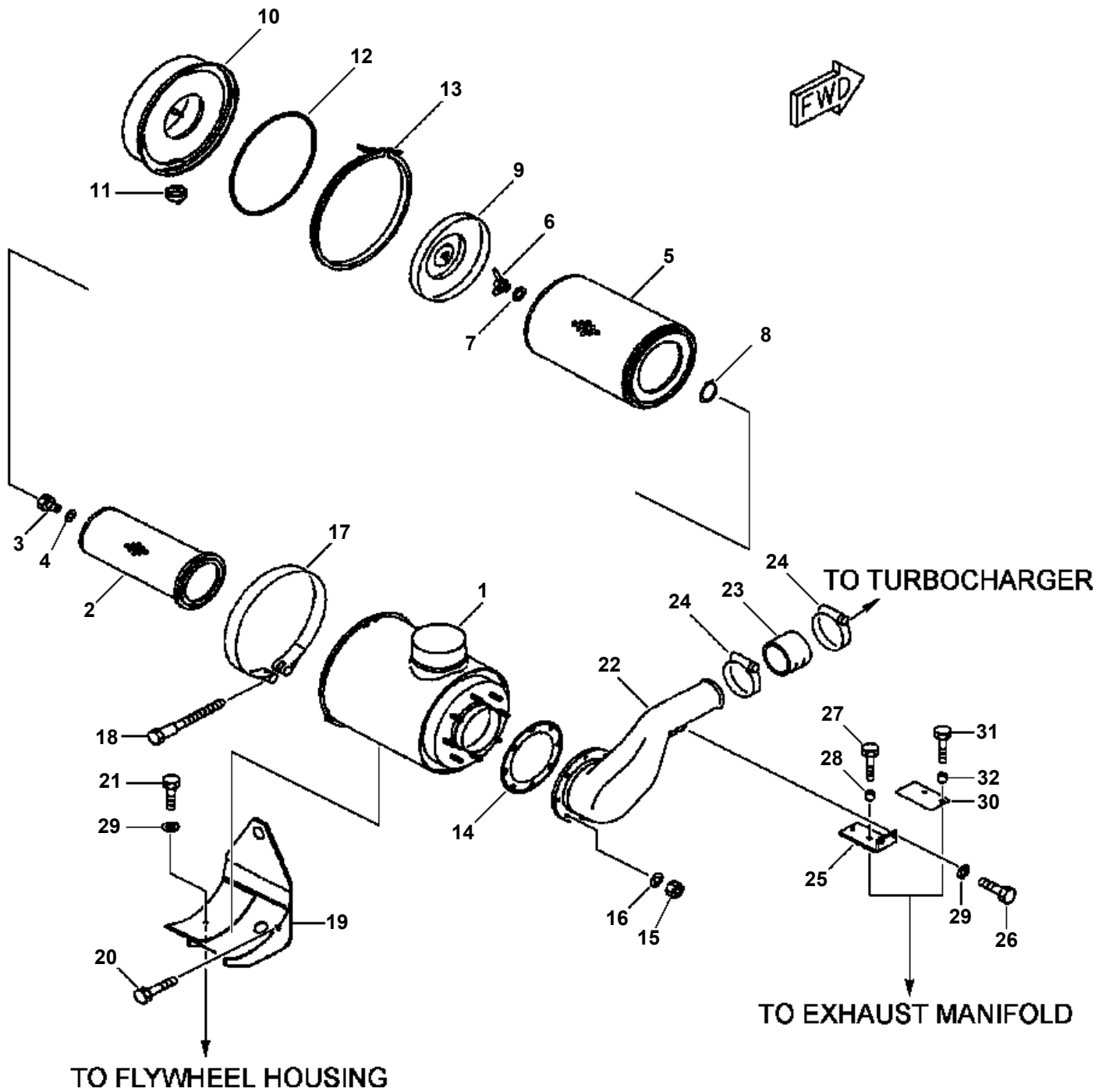

**PW400MH-6 MATERIAL HANDLER S/N A84210-UP
FIG. A1410-A3G5 AIR CLEANER**

ITEM NO.	PART NO.	DESCRIPTION	Q'TY
	6151-81-7700	AIR CLEANER ASSEMBLY	1
1	6692-81-7311	· BODY	1
	6125-81-7032	· ELEMENT ASSEMBLY	1
2	(NSS)	· · ELEMENT, INNER	1
3	600-181-9671	· · NUT	1
4	600-181-7511	· · WASHER	1
	600-181-4300	· · ELEMENT ASSEMBLY, OUTER	1
5	(NSS)	· · · ELEMENT, OUTER	1
6	600-181-1990	· · · NUT, WING	1
7	600-181-4591	· · · WASHER, SEAL	1
8	04064-01510	· · · RING, SNAP	1
9	6710-82-7130	· BAFFLE	1
10	6710-82-7121	· CUP	1
11	600-181-1590	· VALVE	1
12	6127-81-7190	· ORING	1
13	600-181-1490	· CLAMP	1
14	6127-81-4823	GASKET	1
15	01580-11008	NUT	8
16	01640-21016	WASHER	8
17	6691-13-4610	BAND ASSEMBLY	1
	6691-21-6550	· PIN	1
	6691-21-6560	· PIN, WITH THREAD	1
18	6643-11-4641	BOLT	1
19	6152-12-4560	BRACKET	1
20	01010-51660	BOLT	2
21	01010-81025	BOLT	2
22	6152-12-4260	CONNECTOR	1
23	6151-12-4470	HOSE	1
24	07289-00105	CLAMP	2
25	6152-12-4650	BRACKET	1
26	01010-81035	BOLT	2
27	01010-E1040	BOLT	2
28	6631-11-5630	SPACER	2
29	01640-21016	WASHER	4
30	6152-12-4680	PLATE	1
31	01010-E1035	BOLT	2
32	6631-11-5630	SPACER	2

FIG A1510-A3D1

FIG. A1510-A3D1 EXHAUST MANIFOLD

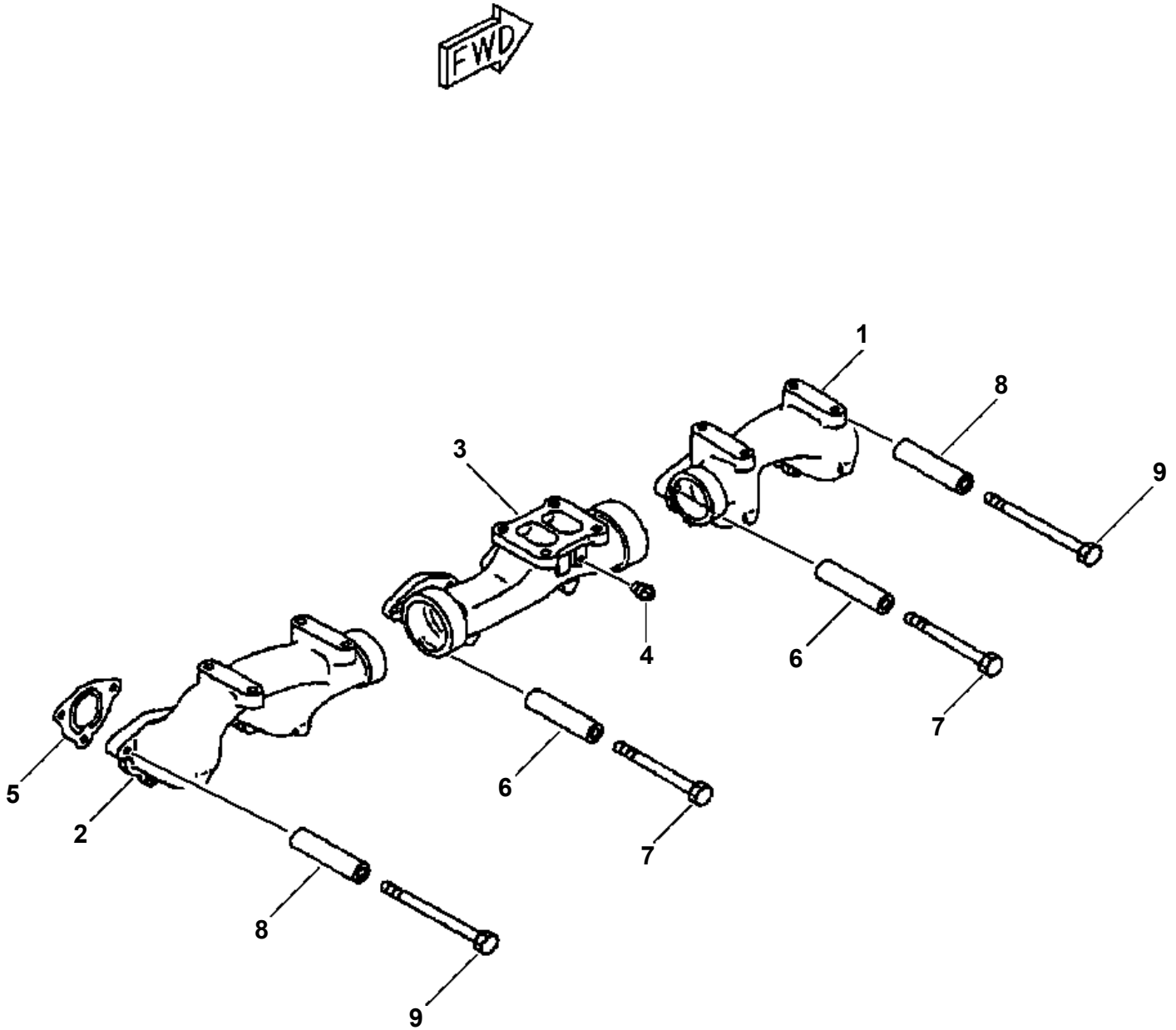

**PW400MH-6 MATERIAL HANDLER S/N A84210-UP
FIG. A1510-A3D1 EXHAUST MANIFOLD**

ITEM NO.	PART NO.	DESCRIPTION	Q'TY	REF
1	6151-11-5110	MANIFOLD, EXHAUST FRONT	1	
2	6151-11-5130	MANIFOLD, EXHAUST REAR	1	
3	6151-11-5160	MANIFOLD, EXHAUST CENTER	1	
4	07042-00108	PLUG	1	
5	6150-11-5810	GASKET	6	F1
6	6136-11-5120	SPACER	16	
7	01011-E1000	BOLT	16	
8	6134-11-5120	SPACER	2	
9	01011-E1080	BOLT	2	
		F1 THIS ITEM ALSO INCLUDED IN CYLINDER HEAD GASKET KIT. REFER TO FIG. A8123-A3A8.		

FIG A1530-A3D8

FIG. A1530-A3D8 TURBOCHARGER PLUMBING

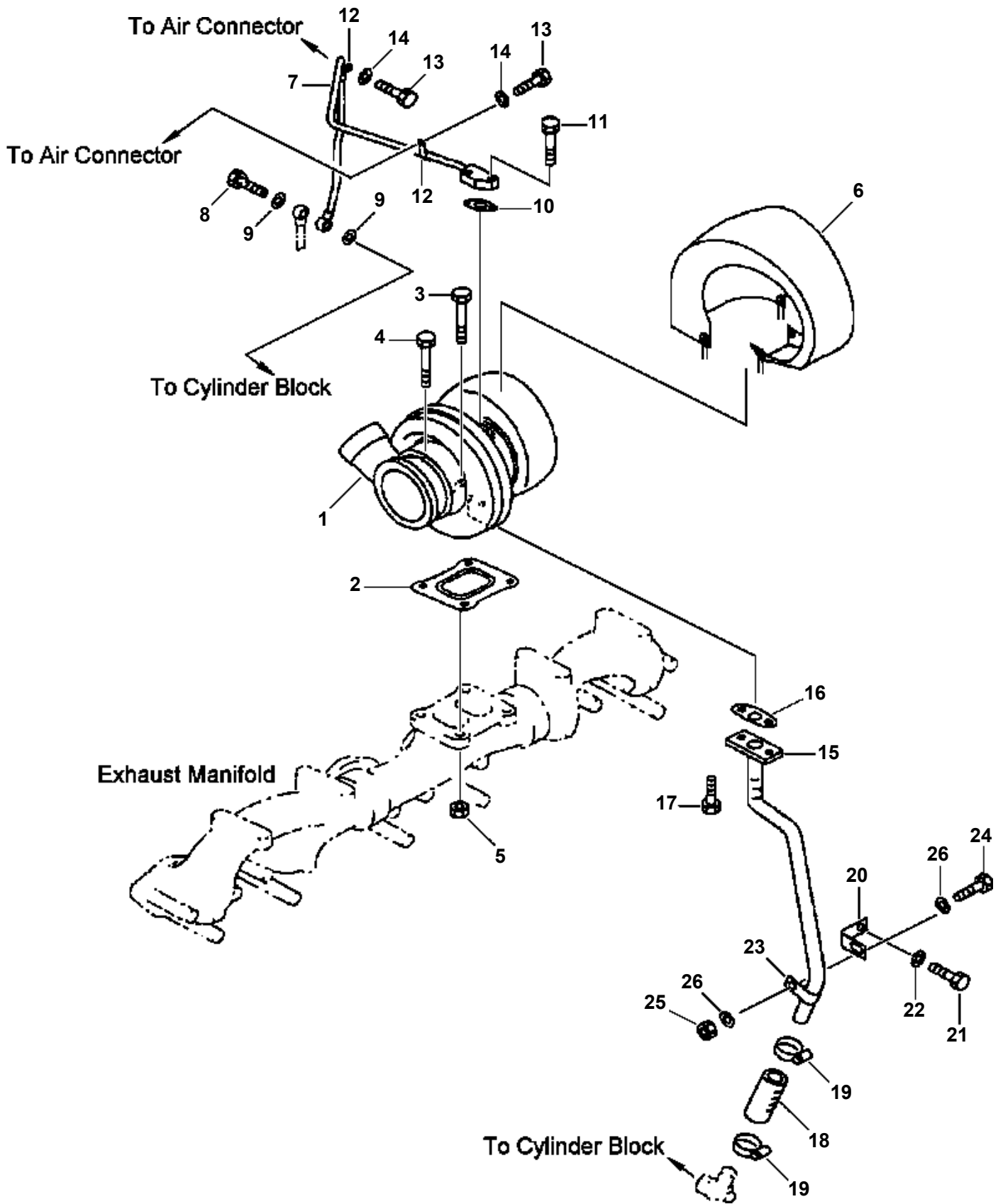

**PW400MH-6 MATERIAL HANDLER S/N A84210-UP
FIG. A1530-A3D8 TURBOCHARGER PLUMBING**

ITEM NO.	PART NO.	DESCRIPTION	Q'TY
1		TURBOCHARGER ASSEMBLY (SEE FIG. A1530-B3D8)	1
2	6151-11-5710	GASKET	1
3	01050-61045	BOLT	2
4	01010-E1035	BOLT	2
5	6114-11-5590	NUT	2
6	6152-12-5410	COVER	1
7	6151-51-8242	TUBE, OIL	1
8	6127-71-5710	BOLT, JOINT	1
9	07005-01412	GASKET	2
10	6221-51-8160	GASKET	1
11	01010-80830	BOLT	2
12	6151-53-8280	CLIP	2
13	01010-81016	BOLT	2
14	01640-21016	WASHER	2
15	6152-52-8350	TUBE, OIL	1
16	6151-51-8721	GASKET	1
17	01010-80820	BOLT	2
18	6210-51-8110	HOSE	1
19	07281-00359	CLAMP	2
20	6151-51-8380	PLATE	1
21	01010-81030	BOLT	1
22	01640-21016	WASHER	1
23	04434-52110	CLIP	1
24	01010-81020	BOLT	1
25	01580-11008	NUT	1
26	01640-21016	WASHER	2

FIG A1530-B3D8

FIG. A1530-B3D8 TURBOCHARGER

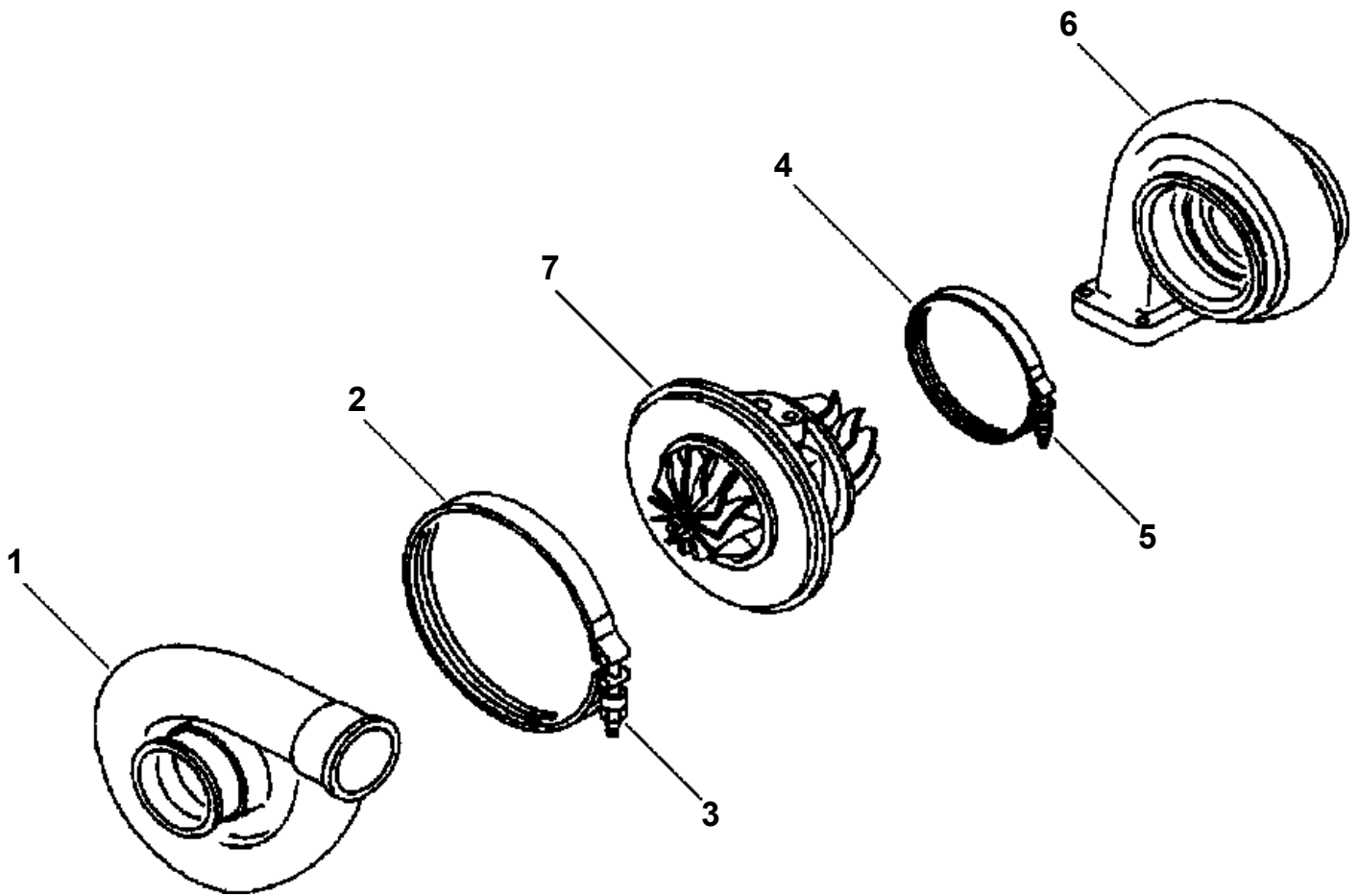

Thank you so much for reading.
Please click the “Buy Now!”
button below to download the
complete manual.



After you pay.

You can download the most
perfect and complete manual in
the world immediately.

Our support email:

ebooklibonline@outlook.com