

KOBELCO

SERVICE MANUAL

HYDRAULIC EXCAVATOR

SK200

SK200LC

Revision Date: 03/1990

Applicable: SK200 LQ-2101~
SK200LC LL-1801~

S5LQ0004E-02

A WARNING

SAFETY

A WARNING

The proper and safe lubrication and maintenance for this machine, recommended by KOBELCO are outlined in the OPERATION & MAINTENANCE GUIDE for this machine.

Improper performance of lubrication or maintenance procedures is dangerous and could result in injury or death. Read and understand the OPERATION & MAINTENANCE GUIDE before performing any lubrication or maintenance.

The serviceman or mechanic may be unfamiliar with many of the systems on this machine. This makes it important to use caution when performing service work. A knowledge of the system and or components is important before the removal or disassembly of any component.

Because of the size of some of the machine components, the serviceman or mechanic should check the weights noted in this Manual. Use proper lifting procedures when removing any components.

Following is a list of basic precautions that should always be observed.

1. Read and understand all Warning plates and decals on the machine before operating, lubricating or repairing this product.
2. Always wear protective glasses and protective shoes when working around machines. In particular, wear protective glasses when pounding on any part of the machine or its attachments with a hammer or sledge. Use welders gloves, hood/goggles, apron and other protective clothing appropriate to the welding job being performed. Do not wear loose-fitting or torn clothing. Remove all rings from fingers when working on machinery.
3. Disconnect battery and discharge any capacitors before starting to work on machine. Hang "Do Not Operate" tag in the Operator's Compartment.
4. If possible, make all repairs with the machine parked on a level, hard surface. Block machine so it does not roll while working on or under machine.
5. Do not work on any machine that is supported only by lift jacks or a hoist. Always use blocks or jack stands to support the machine before performing any disassembly.

A WARNING

Do not operate this machine unless you have read and understand the instructions in the OPERATOR'S MANUAL. Improper machine operation is dangerous and could result in injury or death.

6. Relieve all pressure in air, oil or water systems before any lines, fittings or related items are disconnected or removed. Always make sure all raised components are blocked correctly and be alert for possible pressure when disconnecting any device from a system that utilizes pressure.
7. Lower the bucket, blade, ripper or other implements to the ground before performing any work on the machine. If this cannot be done, make sure the bucket, blade, ripper or other implement is blocked correctly to prevent it from dropping unexpectedly.
8. Use steps and grab handles when mounting or dismounting a machine. Clean any mud or debris from steps, walkways or work platforms before using. Always face machine when using steps, ladders and walkways. When it is not possible to use the designed access system, provide ladders, scaffolds, or work platforms to perform safe repair operations.
9. To avoid back injury, use a hoist when lifting components which weigh 23 kg (50 lbs) or more. Make sure all chains, hooks, slings, etc., are in good condition and are in the correct capacity. Be sure hooks are positioned correctly. Lifting eyes are not to be side loaded during a lifting operation.
10. To avoid burns, be alert for hot parts on machines which have just been stopped and hot fluids in lines, tubes and compartments.
11. Be careful when removing cover plates. Gradually back off the last two bolts or nuts located at opposite ends of the cover or device and pry cover loose to relieve any spring or other pressure, before removing the last two bolts or nuts completely.
12. Be careful when removing filler caps, breathers and plugs on the machine. Hold a rag over the cap or plug to prevent being sprayed or splashed by liquids under pressure. The danger is even greater if the machine has just been stopped because fluids can be hot.

 **WARNING**

13. Always use tools that are in good condition and be sure you understand how to use them before performing any service work.
14. Reinstall all fasteners with same part number. Do not use a lesser quality fastener if replacements are necessary.
15. Repairs which require welding should be performed only with the benefit of the appropriate reference information and by personnel adequately trained and knowledgeable in welding procedures. Determine type of metal being welded and select correct welding procedure and electrodes, rods or wire to provide a weld metal strength equivalent at least to that of parent metal. Always disconnect battery during welding operations to protect sensitive electric equipment.
16. Do not damage wiring during removal operations. Reinstall the wiring so it is not damaged nor will it be damaged in operation by contacting sharp corners, or by rubbing against some object or hot surface. Do not connect wiring to a line containing fluid.
17. Be sure all protective devices including guards and shields are properly installed and functioning correctly before starting a repair. If a guard or shield must be removed to perform the repair work, use extra caution.
18. Loose or damaged fuel, lubricant and hydraulic lines, tubes and hoses can cause fires. Do not bend or strike high pressure lines or install ones which have been bent or damaged. Inspect lines, tubes and hoses carefully. Do not check for leaks with your hands. Pin hole (very small) leaks can result in a high velocity oil stream that will be invisible close to the hose. This oil can penetrate the skin and cause personal injury. Use cardboard or paper to locate pin hole leaks.
19. Tighten connections to the correct torque. Make sure that all heat shields, clamps and guards are installed correctly to avoid excessive heat, vibration or rubbing against other parts during operation. Shields that protect against oil spray onto hot exhaust components in event of a line, tube or seal failure must be installed correctly.
20. Do not operate a machine if any rotating part is damaged or contacts any other part during operation. Any high speed rotating component that has been damaged or altered should be checked for balance before reusing.
21. On track-type machines, be careful when servicing or separating tracks. Chips can fly when removing or installing a track pin. Wear safety glasses and long sleeve shirts. Track can unroll very quickly when separated. Keep away from front and rear of machine. The machine can move unexpectedly when both tracks are disengaged from the sprockets. Block the machine to prevent it from moving.
22. Caution should be used to avoid breathing dust that may be generated when handling components containing asbestos fibers. If this dust is inhaled, it can be hazardous to your health. Components in KOBELCO products that may contain asbestos fibers are brake pads, brake band and lining assemblies, clutch plates and some gaskets. The asbestos used in these components is usually bound in a resin or sealed in some way. Normal handling is not hazardous as long as airborne dust which contains asbestos is not generated.

If dust which may contain asbestos is present, there are several common sense guidelines that should be followed.

- a. Never use compressed air for cleaning.
- b. Avoid brushing or grinding of asbestos containing materials.
- c. For clean up, use wet methods or a vacuum equipped with a high efficiency particulate air (HEPA) filter.
- d. Use exhaust ventilation on permanent machining jobs.
- e. Wear an approved respirator if there is no other way to control the dust.
- f. Comply with applicable rules and regulations for the work place.
- g. Follow environmental rules and regulations for disposal of asbestos.
- h. Avoid areas where asbestos particles may be in the air.

SHOP MANUAL

model

SK 220 SK 220LC

TABLE OF CONTENTS

1. SPECIFICATION	LQ01
2. OPERATION AND CONTROLS (Refer to Operators Manual)	
3. LOCATION AND WEIGHT OF COMPONENTS	LQ03
4. MAINTENANCE STANDARDS AND TEST PROCEDURES	LQ04
5. TROUBLESHOOTING	LQ05
6. PREVENTIVE MAINTENANCE (Refer to Operators Manual)	
7. WORKING STANDARDS	LQ07

○How to Index each Shop Manual Section
The GENERAL of this shop manual consists of 7 headings as shown above. Each section can be easily referred to by indexes appended to the margin of the page as indicated on the right. Please use the indexes for speedy reference.

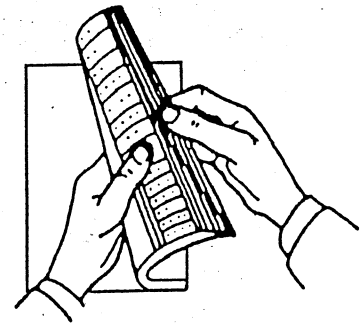

KOBELCO

GENERAL

SK220 List of Shop Manual GENERAL Section
 SK220_{LC}

Index No.	Title	Book Code No.		
		Distribution Year - Month		
LQ01	SPECIFICATION	S5LQ0104E① 1991-12		
	OPERATION	S2LQ1016E Refer to Operators manual		
LQ03	LOCATION AND WEIGHT OF COMPONENTS	S5LQ0304E 1990-3		
LQ04	MAINTENANCE STANDARDS AND TEST PROCEDURES	S5LQ0405E 1990-3		
LQ05	TROUBLESHOOTING	S5LQ0504E① 1993-2		
	PREVENTIVE MAINTENANCE	S2LQ1016E Refer to Operators manual		
LQ07	WORKING STANDARDS	S5LQ0704E 1990-3		
	Applicable Machines	LQ-2101~ LL-1801~		

Book code No.

S5LQ0104E①

KOBELCO

SHOP MANUAL

SK 220 SK 220LC

LQ01

SPECIFICATION

TABLE OF CONTENTS

1. NAME OF COMPONENTS	1
2. GENERAL DIMENSIONS	2
3. SPECIFICATIONS AND PERFORMANCE	4
4. TYPE OF SHOES	5
5. TYPE AND COMBINATION OF ATTACHMENTS	6
6. WORKING RANGES OF ATTACHMENTS	7
7. LIFTING-UP ABILITY DIAGRAM	9
8. ENGINE SPECIFICATIONS	14

Applicable Machines
LQ-2101~
LL-1801~

Revision	Date of Issue	Remarks
First edition	March, 1990	S5LQ0104E K
First revision	December, 1991	S5LQ0104EⒹ K

1. NAME OF COMPONENTS

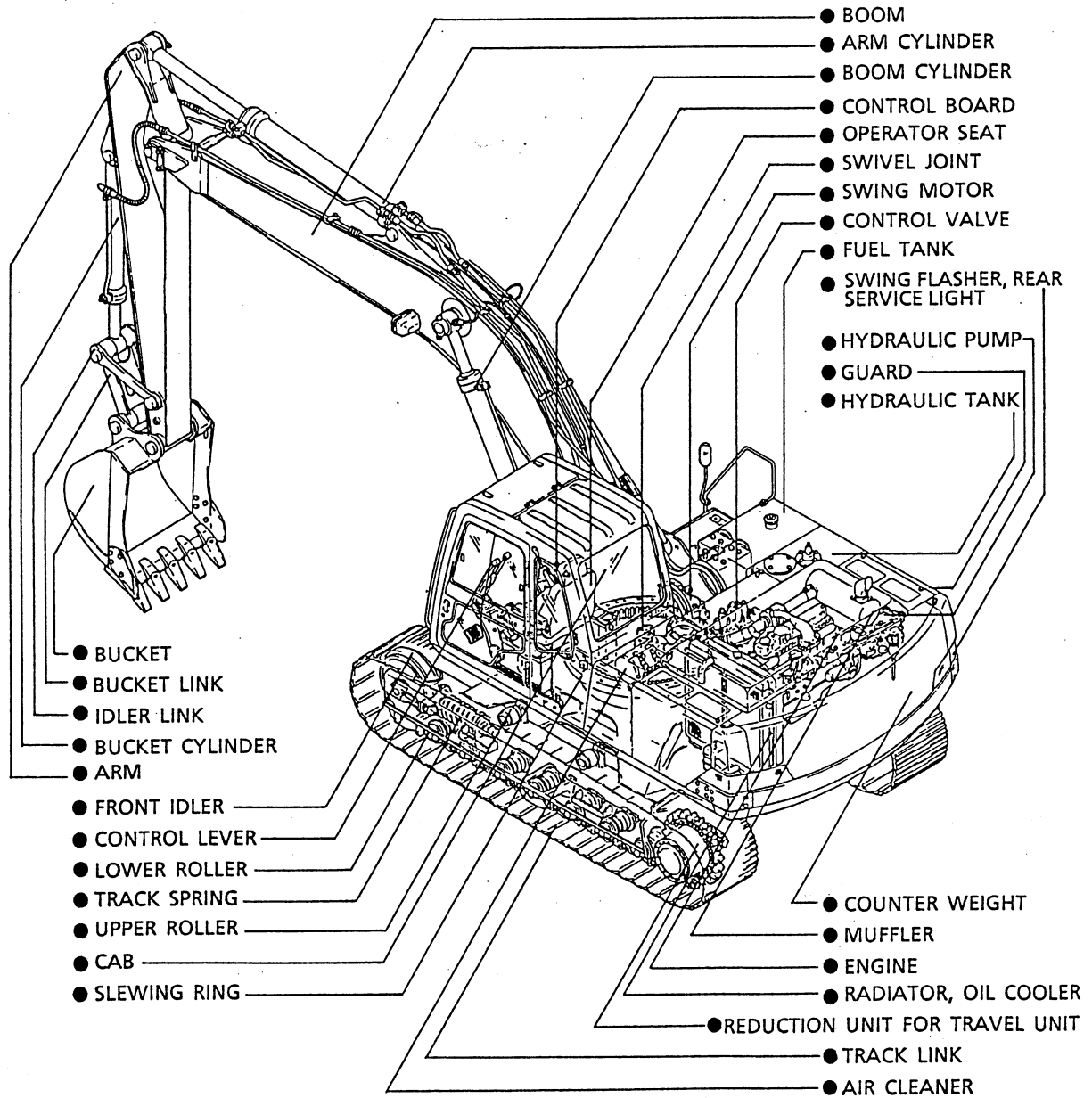

2. GENERAL DIMENSIONS

■ SK220 (6.02m (19ft 9in) BOOM + 2.98m (9ft 9in) ARM-ATTACHED STANDARD MACHINE)
Unit : mm (ft-in)

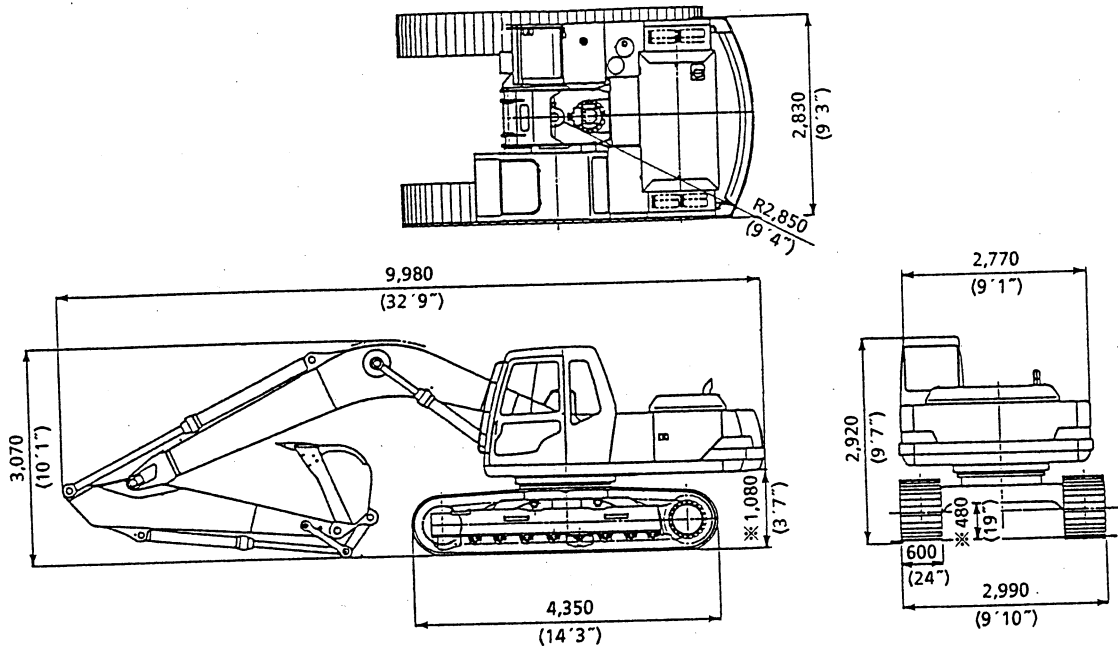

■ SK220LC (6.02m (19ft 9in) BOOM + 2.98m (9ft 9in) ARM-ATTACHED STANDARD MACHINE)

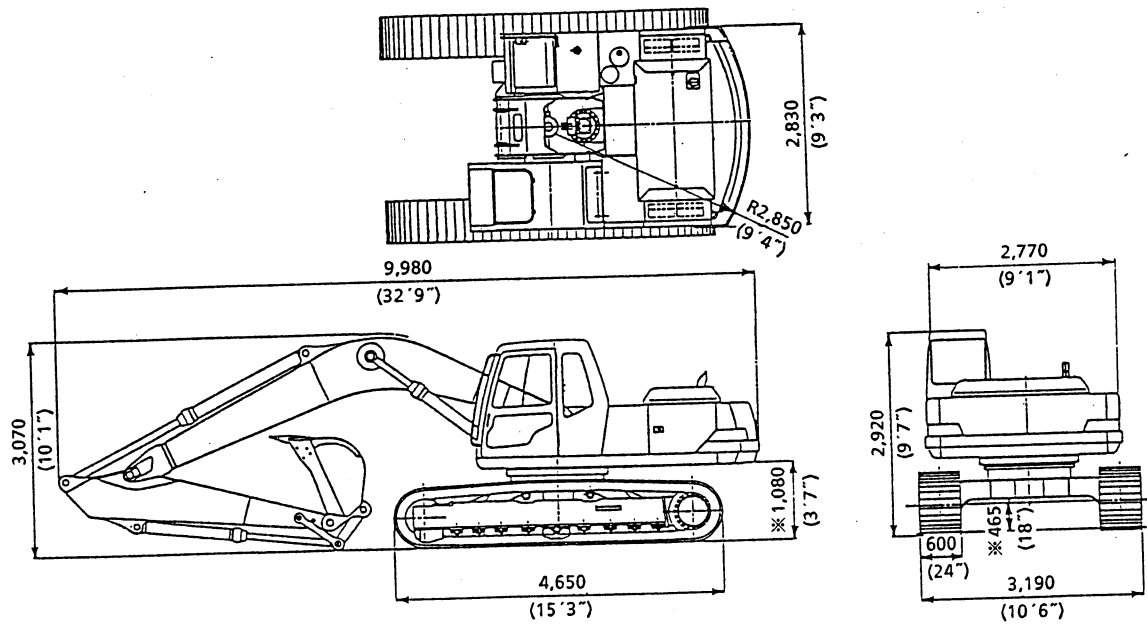

☞ The figures marked \approx in the illustration do not include the shoe embossment (26mm) (1.02").

■ SK220 (WITH 6.02m (19ft 9in) BOOM + 2.5m (8ft 2in) ARM)

Unit : mm [ft-in]

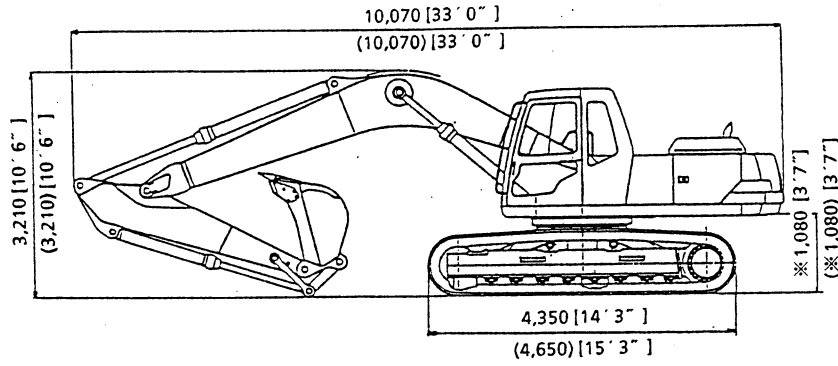

■ SK220 (WITH 6.02m (19ft 9in) BOOM + 3.66m (12ft) ARM)

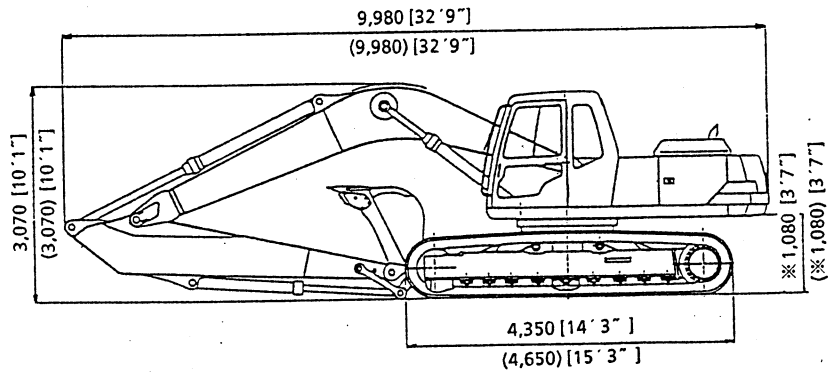

- The figures marked ※ in the illustration do not include the shoe embossment (26mm) [1.02"].
- SK200lc has the dimensions given in parentheses [].

3. SPECIFICATIONS AND PERFORMANCE

■ SPEED AND CLIMBING ABILITY

Item	Model	SK220	SK220LC
Swing speed		12rpm	
Travel speed		7.4km/h (4.3/2.5 MPH)	
Gradeability		35° (70%)	

■ ENGINE

Model	Mitsubishi 6 D15-T		
Type	Water-cooled 4-cycle, direct injection type with exhaust turbo supercharger		
Number of cylinder - Bore x Stroke	6 - 113mm(4.45in) x 115mm(4.53in)		
Total displacement	6,919c.c. (422cuin)		
Rated output power/revolution	JIS D 1005 Net	165ps/2,150rpm	
	SAE J 1345 Net	121kw/2,150rpm	
	DIN 6270 Net	121kw/2,150rpm	
Maximum torque/revolution	JIS D 1005 Net	60kgf-m / 1,600rpm	
	SAE J 1349 Net	588N-m / 1,600rpm	
	DIN 6270 Net	60kgf-m / 1,600rpm	

■ HYDRAULIC COMPONENTS

Hydraulic pump	Double-pump variable displacement, axial piston + gear pump
Hydraulic motor (swing)	Axial piston motor
Hydraulic motor (travel)	Axial piston motor
Control valve	5-section multiple control valve + 1-section control valve (swing)
Cylinders (boom, arm, and bucket)	Double acting cylinder
Return filter	Safety valve containing filter type
Oil cooler	Air-cooled type

■ WEIGHT

Unit : kg (lbs)

Fully-equipped weight	22,900 (50,500)	23,500 (51,800)
Upper machinery	9,980 (22,000)	←
Lower machinery (with 600mm (24") grocer shoe)	8,860 (19,500)	9,460 (20,900)
Attachment [6.02m(19ft 9in) boom + 2.98m (9ft 9in) arm + 0.9m ³ (0.92cuyd) bucket]	4,070 (8,970)	←

Thank you so much for reading.
Please click the “Buy Now!”
button below to download the
complete manual.



After you pay.

You can download the most
perfect and complete manual in
the world immediately.

Our support email:

ebooklibonline@outlook.com