

HYDRAULIC EXCAVATOR

**SHOP
MANUAL**

model

**SK200-8
SK210LC-8**

INDEX

1	SPECIFICATIONS SECTION
2	MAINTENANCE SECTION
3	SYSTEM SECTION
4	DISASSEMBLY SECTION
5	TROUBLESHOOTING
6	ENGINE SECTION
7	PROCEDURE OF INSTALLING OPTIONS SECTION

MAINTENANCE SPECIFICATIONS

SYSTEM

DISASSEMBLING

E/G TROUBLESHOOTING

OPT.

KOBELCO



Book Code No. **S5YN0018E03**

INDEX

SK200-8
SK210LC-8

Book Code No. Distribution Year-Month			Title	Index No.
S5YN0118E01 2006-8		SPECIFICATIONS	OUTLINE	1
S5YN0218E02 2007-2			SPECIFICATIONS	2
S5YN0318E01 2006-8			ATTACHMENT DIMENSIONS	3
S5YN1118E02 2008-10		MAINTENANCE	TOOLS	11
S5YN1218E01 2006-8			STANDARD MAINTENANCE TIME SCHEDULE	12
S5YN1318E02 2007-2			MAINTENANCE STANDARD AND TEST PROCEDURE	13
S5YN2118E03 2008-10		SYSTEM	MECHATRO CONTROL SYSTEM	21
S5YN2218E02 2007-2			HYDRAULIC SYSTEM	22
S5YN2318E02 2007-2			ELECTRIC SYSTEM	23
S5YN2418E02 2007-2			COMPONENTS SYSTEM	24
S5YN2518E02 2007-2			AIR-CONDITIONER SYSTEM	25
—				
S5YN3118E01 2006-8		DISASSEMBLING	DISASSEMBLING & ASSEMBLING	31
S5YN3218E02 2007-2			ATTACHMENT	32
S5YN3318E02 2007-2			UPPER STRUCTURE	33
S5YN3418E02 2007-2			TRAVEL SYSTEM	34
S5YN4618E03 2008-10		TROUBLESHOOTING	BY ERROR CODES	46
S5YN4718E01 2006-8			BY TROUBLE	47
S5YN4818E01 2006-8			TROUBLE DIAGNOSIS MODE	48
—				
S5YN5118E03 2008-10		E/G	ENGINE	51
—				
—				
—				
YN11-45001~ YQ11-06001~			APPLICABLE MACHINES	

NOTE:

This Manual is prepared as a technical material in which the information necessary for the maintenance and repairing services of our hydraulic excavators are collected, and is categorized into 7 Chapters, Specification, Maintenance, System, Disassembly, Troubleshooting, Engine, and Installation Procedures for Optional Attachment.

- The Chapter "Specification" describes the specifications for entire machine and material, which are instructive for replacement and repairing of attachments.
- The Chapter "Maintenance" describes the material, which is helpful for maintenance service and adjustments for entire machine.
- The Chapter "System" describes the operating system like hydraulic system, electric system, components, and so on.
- The Chapter "Disassembly" describes the removal and installing of assembly mounted on the upper structure and undercarriage, and the assembling and disassembling of the associated hydraulic equipment.
- The Chapter "Troubleshooting" describes how to find the fault equipment.
- The Chapter "Engine" describes the engines making use of the "Maintenance Manual" provided by the suppliers.
- The Chapter "Installation Procedures for Optional Attachment" describes the supplements added on request as required.

This Manual may be properly revised due to the improvement of products, modification of specifications, etc. And there are cases where the system on actual machine and a part of the contents of this manual may differ due to the variations of specification by countries. For the section in which the description is hardly understood, contact our distributor.

The number is assigned to every part handled in this Manual on account of the description, but the parts, which cannot be supplied as service parts are contained. Therefore, the order must be placed with respective formal number with due confirmation on the Parts Manual for applicable machine.

1. OUTLINE

TABLE OF CONTENTS

1.1	GENERAL PRECAUTIONS FOR MAKING REPAIRS	1-3
1.1.1	PREPARATION BEFORE DISASSEMBLING	1-3
1.1.2	SAFETY WHEN DISASSEMBLING AND ASSEMBLING	1-3
1.1.3	DISASSEMBLING AND ASSEMBLING HYDRAULIC EQUIPMENT	1-3
1.1.4	ELECTRICAL EQUIPMENT	1-4
1.1.5	HYDRAULIC PARTS	1-5
1.1.6	WELD REPAIR	1-5
1.1.7	ENVIRONMENTAL ISSUES	1-5
1.2	INTERNATIONAL UNIT SYSTEM	1-6

1. OUTLINE

Issue	Date of Issue	Applicable Machines	Remarks
First edition	July, 2006	SK330-8 : LC10-07001~ SK350LC-8 : YC10-03501~	S5YN0118E01 (ASIA, OCE) K
↑	August, 2006	SK200-8 : YN11-45001~ SK210LC-8 : YQ11-06001~	↑ K

1.1 GENERAL PRECAUTIONS FOR MAKING REPAIRS

1.1.1 PREPARATION BEFORE DISASSEMBLING



- (1) Knowledge of operating procedure
Read Operator's Manual carefully to understand the operating procedure.
- (2) Cleaning machines
Clean machines of soil, mud, and dust before carrying into the service shop.
Carrying a soiled machine into the service shop, causes making less efficient work and damage of parts.
- (3) Inspecting machines
Confirm the disassembling section before starting work, determine the disassembly procedure taking the conditions in work shop into account, and request to procure necessary parts in advance.
- (4) Recording
Record the following items to keep contact and prevent malfunction from recurring.
 - 1) Inspecting date, place
 - 2) Model name, Serial number and Record on hour meter
 - 3) Trouble condition, place, cause
 - 4) Visible oil leak, water leak and damage
 - 5) Clogging of filters, oil level, oil quality, oil contamination and looseness.
 - 6) Examine the problems on the basis of monthly operation rate with the last inspection date and records on hour meter.
- (5) Arrangement and cleaning in service shop
 - 1) Tools required for repair work.
 - 2) Prepare the places to put the disassembled parts.
 - 3) Prepare oil pans for leaking oil, etc.

1.1.2 SAFETY WHEN DISASSEMBLING AND ASSEMBLING



- (1) Safety
 - 1) Wear appropriate clothing, safety shoes, safety helmet, goggles, and clothes with long sleeves.

- 2) Attach "Don't operate" tag to control lever, and begin a meeting before starting the work.
- 3) Before starting inspection and maintenance stop the engine.
- 4) Confirm the position of first-aid kit and fire extinguisher, and also where to make contact for emergency measure and ambulance to prepare for accidents and fire.
- 5) Choose a hard, level and safe place, and put attachment on the ground without fail.
- 6) Use hoist, etc. to remove parts of heavy weight (23kg [50 lb] or more).
- 7) Use proper tools, and change or repair defective tools.
- 8) Machine and attachment required to work in the lifting condition should be supported with supports or blocks securely.

1.1.3 DISASSEMBLING AND ASSEMBLING HYDRAULIC EQUIPMENT



- (1) Removing hydraulic equipment assy
 - 1) Before removing pipes, release the pressure of hydraulic oil tank, or open the cover on the return side to tank, and take out the filter.
 - 2) Drain the oil in the removed pipes into pan to prevent the oil from spilling on the ground.
 - 3) Pipes with plugs or caps to prevent oil leaking, entry of dust, etc.
 - 4) Clean the outside surface of equipment, etc. before disassembling, and drain hydraulic oil and gear oil before putting them on working bench.
- (2) Disassembling hydraulic equipment
 - 1) Since performance and function of hydraulic equipment after disassembly and assembly results in immunity from responsibility on the manufacture's side, disassembly, assembly and modification without permission are strictly prohibited.
 - 2) If it is unavoidably necessary to disassemble and modify, it should be carried out by experts or personnel qualified through service training.
 - 3) Make match mark on parts for reassembling.
 - 4) Before disassembling, read Disassembling Instruction in advance, and determine if the disassembly and assembly are permitted or not.

1. OUTLINE

- 5) For parts which are required to use jig and tools, don't fail to use the specified jig and tools.
 - 6) For parts which can not be removed in the specified procedure, never force removal. First check for the cause.
 - 7) The removed parts should be put in order and tagged so as to install on proper places without confusion.
 - 8) For common parts, pay attention to the quantity and places.
- (3) Inspecting parts
- 1) Check that the disassembled parts are free from adherence, interference and uneven working face.
 - 2) Measure the wear of parts and clearance, and record the measured values.
 - 3) If an abnormality is detected, repair or replace the parts.
- (4) Reassembling hydraulic equipment
- 1) During the parts cleaning, ventilate the room.
 - 2) Before assembly, clean parts roughly first, and then completely.
 - 3) Remove adhering oil by compressed air, and apply hydraulic oil or gear oil, and then assemble them.
 - 4) Replace the removed O-ring, back-up rings and oil seal with new ones, and apply grease oil on them before assembling.
 - 5) Removes dirt and water on the surface on which liquid sealant are applied, decrease them, and apply liquid sealant on them.
 - 6) Before assembling, remove rust preventives on new parts.
 - 7) Use special tools to fit bearings, bushing and oil seal.
 - 8) Assemble parts matching to the marks.
 - 9) After completion, check that there is no omission of parts.
- (5) Installing hydraulic equipment
- 1) Confirm hydraulic oil and lubrication oil.
 - 2) Air release is required in the following cases ;
 1. Change of hydraulic oil
 2. Replacement of parts on suction pipe side
 3. Removing and attaching hydraulic pump
 4. Removing and attaching swing motor
 5. Removing and attaching travel motor
 6. Removing and attaching hydraulic cylinder



WARNING
If hydraulic oil and lubricating oil are not filled and also air bleed is not performed, the hydraulic equipment may be damaged.

- 3) For air bleed of hydraulic pump and swing motor, loosen drain plug on the upper part, start engine, and run in low idling, then bleed air until hydraulic oil is comes out. After completion of comes, tighten plug securely.
- 4) For air bleed of travel motor and hydraulic cylinder, starts engine and operate it for 10 minutes or more at no-load and low speed.



WARNING
For cylinder, don't move it to the stroke end at beginning.

- 5) Air in pilot circuit can be bleed out by only operating digging, swing and traveling motions thoroughly.
- 6) Check hydraulic oil level.
Move attachments to hydraulic oil check position, and check hydraulic oil level of tank. Refill oil if the oil level is lower than the specified level.
How to check oil level of hydraulic oil tank

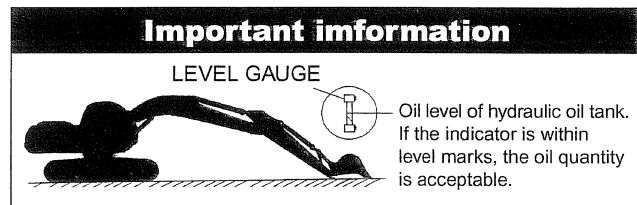

1.1.4 ELECTRICAL EQUIPMENT

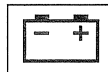

- (1) The disassembly of electrical equipment is not allowed.
- (2) Handle equipment with care so as not to drop it or bump it.
- (3) Connector should be removed by unlocking while holding the connector.
Never stress in tension to the caulked section by pulling wire.
- (4) Check that connector is connected and locked completely.
- (5) Engine key off before removing and connecting connector.

- (6) Engine key off before touching terminals of starter and alternator.
 - (7) Remove battery grounding terminal before beginning work close to battery and battery relay with tools.
 - (8) Wash machine with care so as not to splash water on electrical equipment and connector.
 - (9) When water has entered in the waterproofed connector, the removing of water is not easy. So check the removed waterproofed connector with care to protect it from entry of water. If moisture adheres on it, dry it completely before connecting.
- (2) Flexible hose (F hose)
 - Even if the connector and length of hose are the same, the parts differ according to the withstanding pressure. Use proper parts.
 - Tighten it to the specified torque, and check that it is free from twist, over tension, interference, and oil leak.



Battery fluid is dangerous.

The battery fluid is dilute sulfuric acid, and causes scald and loss of eyesight by adhering on eyes, skin and clothes. When the fluid has adhered on them, take an emergency measure immediately and see a doctor for medical advice.

- **When it has adhered on skin ;
Wash with soap and water.**
- **When it has got in eyes ;
Wash in water for 10 minutes or more immediately.**
- **When it has spilled out in large quantity ;
Use sodium bicarbonate to neutralize, or wash away with water.**
- **When it was swallowed ;
Drink milk or water.**
- **When it has adhered on clothes ;
Wash it immediately.**

1.1.5 HYDRAULIC PARTS

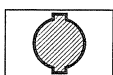

- (1) O-ring
 - Check that O-ring is free from flaw and has elasticity before fitting.
 - Even if the size of O-ring is equal, the usage differs, for example in dynamic and static sections, the rubber hardness also differs according to the pressure force, and also the quality differs depending on the materials to be seated. So, choose proper O-ring.
 - Fit O-ring so as to be free from distortion and bend.
 - Floating seal should be put in pairs.

1.1.6 WELD REPAIR

- (1) The weld repair should be carried out by qualified personnel in the specified procedure after disconnecting the grounding cable of battery. If the grounding cable is not disconnected, the electrical equipment may be damaged.
- (2) Remove parts which may cause fire due to the entry of spark beforehand.
- (3) Repair attachments which are damaged, giving particular attention to the plated section of piston rod to protect it from sparks, and don't fail to cover the section with flame-proof clothes.

1.1.7 ENVIRONMENTAL ISSUES

- (1) Engine should be started and operated in the place where air can be sufficiently ventilated.
- (2) Waste disposal
The following parts follows the regulation.
Waste oil, waste container and battery
- (3) Precautions for handling hydraulic oil
Hydraulic oil may cause inflammation of eyes.
Wear goggles to protect eyes on handling it.
 - When it has got in eyes ;
Wash eyes with water until the stimulus is gone.
 - When it was swallowed ;
Don't force him to vomit it, but immediately receive medical treatment.
 - When it has adhered on skin ;
Wash with soap and water.
- (4) Others
For spare parts, grease and oil, use KOBELCO genuine ones.

1. OUTLINE

1.2 INTERNATIONAL UNIT SYSTEM

Introduction

Although this manual uses the SI units system. Outline of SI units system is described here.

Given hereinunder are an excerpt of the units that are related to this manual :

1. Etymology of SI Units

English : International System of units

2. Construction of SI Unit System

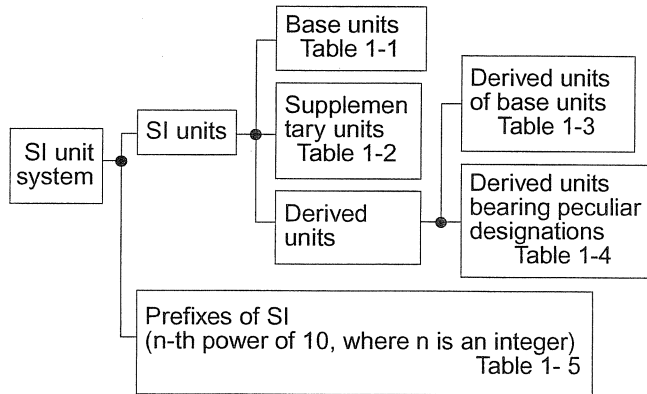

(1) Basic Units

Table1-1

QUANTITIES	DESIGNATION	SIGN
Length	Meter	m
Mass	Kilogram	kg
Time	Second	s
Current	Ampere	A
Thermodynamic temperature	Kelvin	K
Gram molecule	Mol	mol
Luminous intensity	Candela	cd

(2) Supplementary Units

Table1-2

QUANTITIES	DESIGNATION	SIGN
Plain angle	Radian	rad
Solid angle	Steradian	sr

(3) Derived Units of Basic Units

Table1-3

QUANTITIES	DESIGNATION	SIGN
Area	Square meter	m ²
Volume	Cubic meter	m ³
Velocity	Meter per second	m/s
Acceleration	Meter per second / second	m/s ²
Density	Kilogram per cubic meter	kg/m ³

(4) Derived Units bearing Peculiar Designations

Table1-4

QUANTITY	UNIT	SYMBOL	FORMULA
Frequency	hertz	Hz	1Hz=1/s
Force	newton	N	kg • m/s ²
Pressure and Stress	pascal	Pa	N/m ²
Energy, Work and Quantity of heat	joule	J	N•m
Power	watt	W	J/s
Quantity of electricity	coulomb	C	A•s
Electric potential difference, Voltage, and Electromotive force	volt	V	W/A
Quantity of static electricity and Electric capacitance	farad	F	C/V
Electric resistance	ohm	Ω	V/A
Celcius temperature	celcius degree or degree	°C	(t+273.15)K
Illuminance	lux	lx	l m/m ²

(5) Prefixes of SI

Table1-5

PREFIX		POWER
DESIGNATION	SIGN	
Giga	G	10 ⁹
Mega	M	10 ⁶
Kilo	k	10 ³
Hecto	h	10 ²
Deca	da	10
Deci	d	10 ⁻¹
Centi	c	10 ⁻²
Milli	m	10 ⁻³
Micro	μ	10 ⁻⁶
Nano	n	10 ⁻⁹
Pico	p	10 ⁻¹²

(6) Unit Conversion Table

QUANTITIES	JIS	SI	REMARKS
Mass	kg	kg	
Force	kgf	N	1kgf=9.807N
Torque	kgf·m	N·m	1kgf·m=9.807N·m
Pressure	kgf/cm ²	MPa	1kgf/cm ² =0.098MPa
Motive power	PS	kW	1PS=0.7355kW
Revolution	r.p.m	min ⁻¹	1r.p.m=1min ⁻¹

[MEMO]

2. SPECIFICATIONS

TABLE OF CONTENTS

- 2.1 NAME OF COMPONENTS.....2-3
- 2.2 GENERAL DIMENSIONS.....2-4
 - 2.2.1 SK200-8/SK210LC-8
[5.65m (18ft-6in) Boom+2.94m (9ft-8in) Standard Arm+0.80m³ (1.05cu*yd) Bucket Shoe]....2-4
 - 2.2.2 SK200-8/SK210LC-8
[5.65m (18ft-6in)+2.4m (7ft-10in) Short Arm+0.93m³ (1.22cu*yd) Bucket Shoe]2-4
 - 2.2.3 SK200-8/SK210LC-8
[5.65m (18ft-6in) Boom+3.5m (11ft-6in) Long Arm+0.70m³ (0.92cu*yd) Bucket Shoe].....2-5
- 2.3 WEIGHT OF COMPONENTS.....2-6
- 2.4 TRANSPOTATION2-8
 - 2.4.1 OVERALL DIMENSIONS OF MACHINE ON A TRAILER.....2-8
 - 2.4.2 DIMENSIONS OF ATTACHMENT2-9
- 2.5 SPECIFICATIONS AND PERFORMANCE2-11
 - 2.5.1 SPEED AND CLIMBING CAPABILITY2-11
 - 2.5.2 ENGINE2-11
 - 2.5.3 HYDRAULIC COMPONENTS2-11
 - 2.5.4 WEIGHT2-11
- 2.6 TYPE OF CRAWLER.....2-12
- 2.7 TYPE OF BUCKET2-12
- 2.8 COMBINATIONS OF ATTACHMENT.....2-13
- 2.9 ENGINE SPECIFICATIONS2-14
 - 2.9.1 SPECIFICATIONS.....2-14
 - 2.9.2 ENGINE CHARACTERISTIC CURVE (HINO J05E-TA)2-15



2. SPECIFICATIONS

Issue	Date of Issue	Applicable Machines	Remarks
First edition	August, 2006	SK200-8 : YN11-45001~ SK210LC-8 : YQ11-06001~	S5YN0218E01 (ASIA, OCE) K
Revision	February, 2007	↑	S5YN0218E02 (ASIA, OCE) K

2.1 NAME OF COMPONENTS

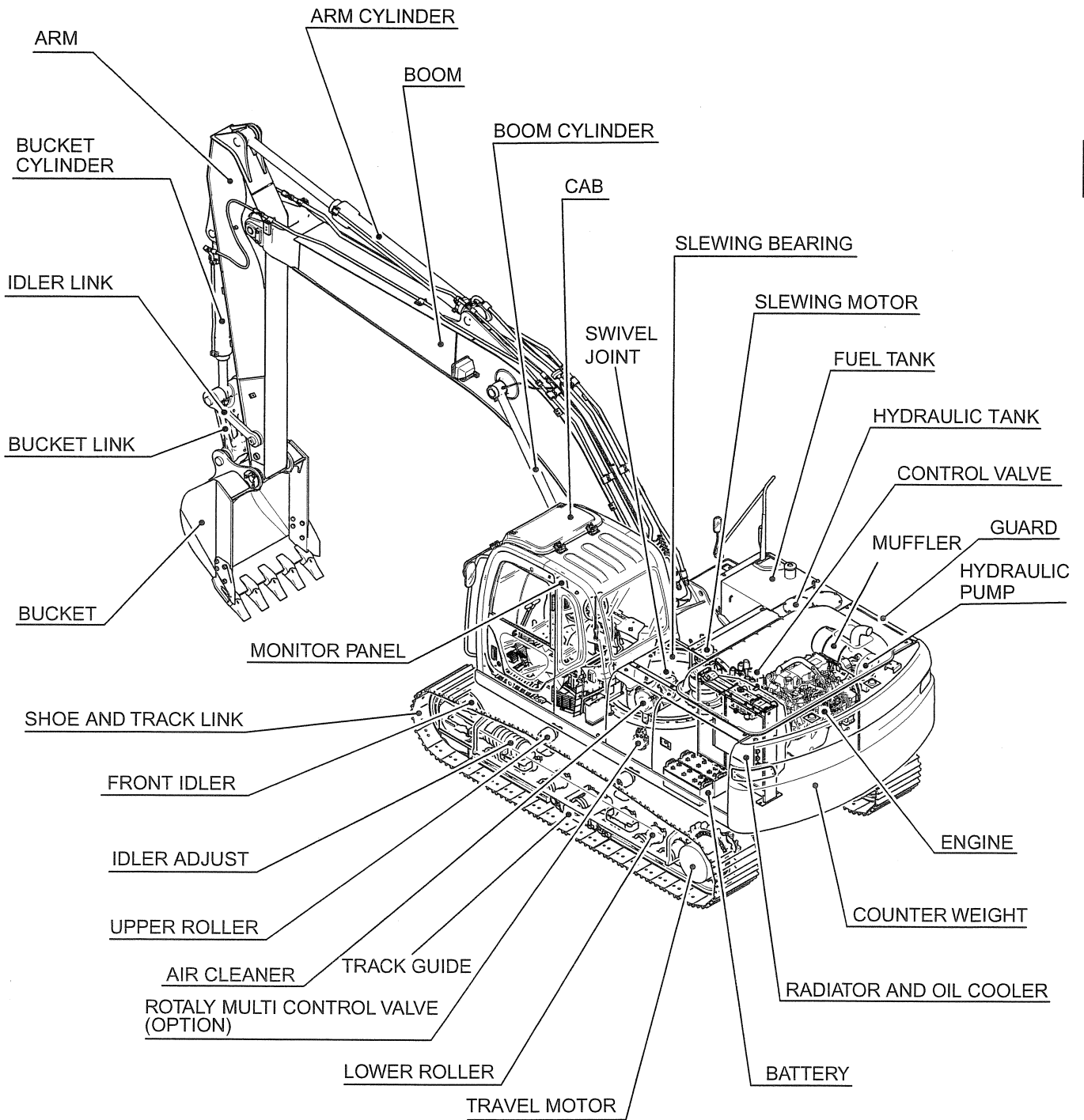

2. SPECIFICATIONS

2.2 GENERAL DIMENSIONS

2.2.1 SK200-8/SK210LC-8 [5.65m (18ft-6in) Boom+2.94m (9ft-8in) Standard Arm+0.80m³ (1.05cu-yd) Bucket Shoe]

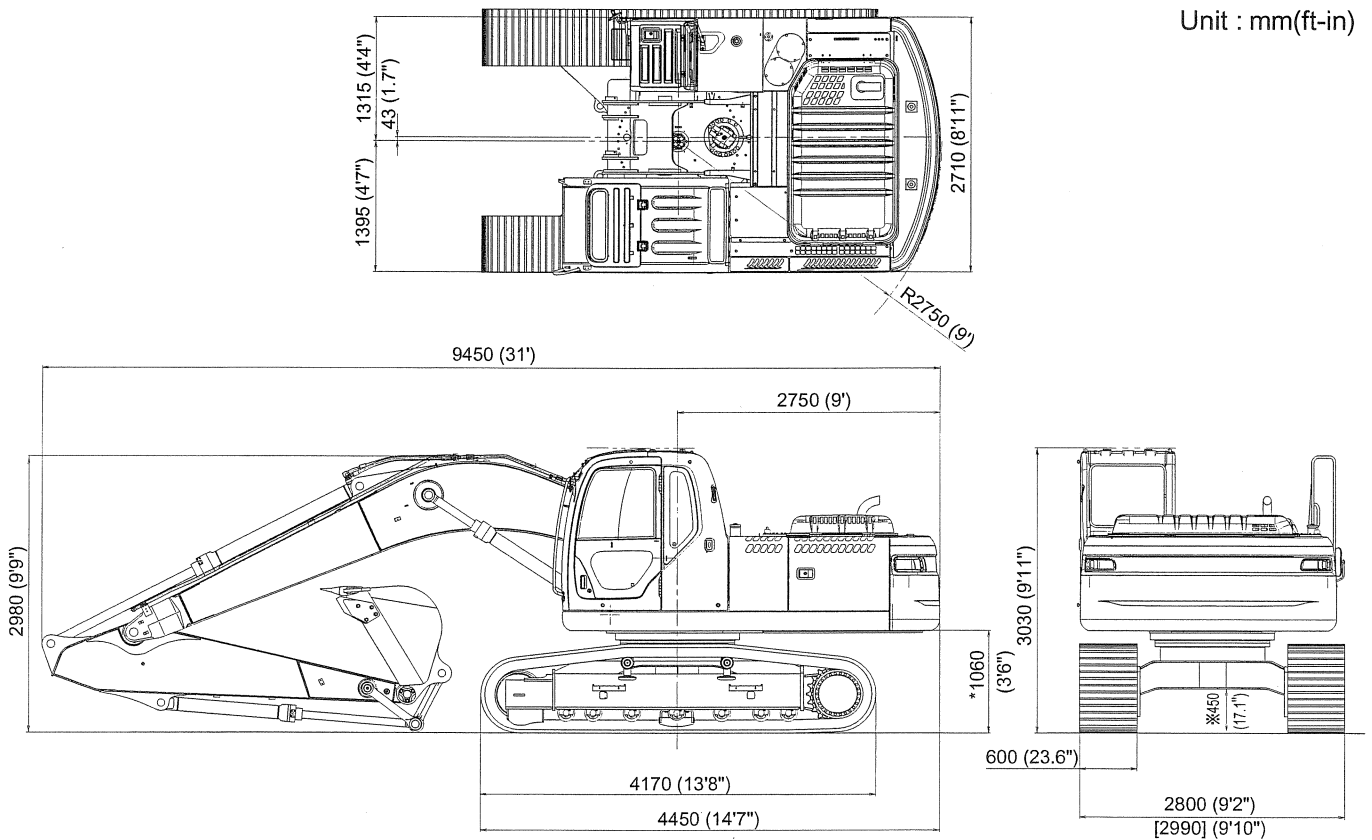

Note

Dimensions marked * do not include the height of the shoe lug.
 [] include LC specifications.

2.2.2 SK200-8/SK210LC-8 [5.65m (18ft-6in)+2.4m (7ft-10in) Short Arm+0.93m³ (1.22cu-yd) Bucket Shoe]

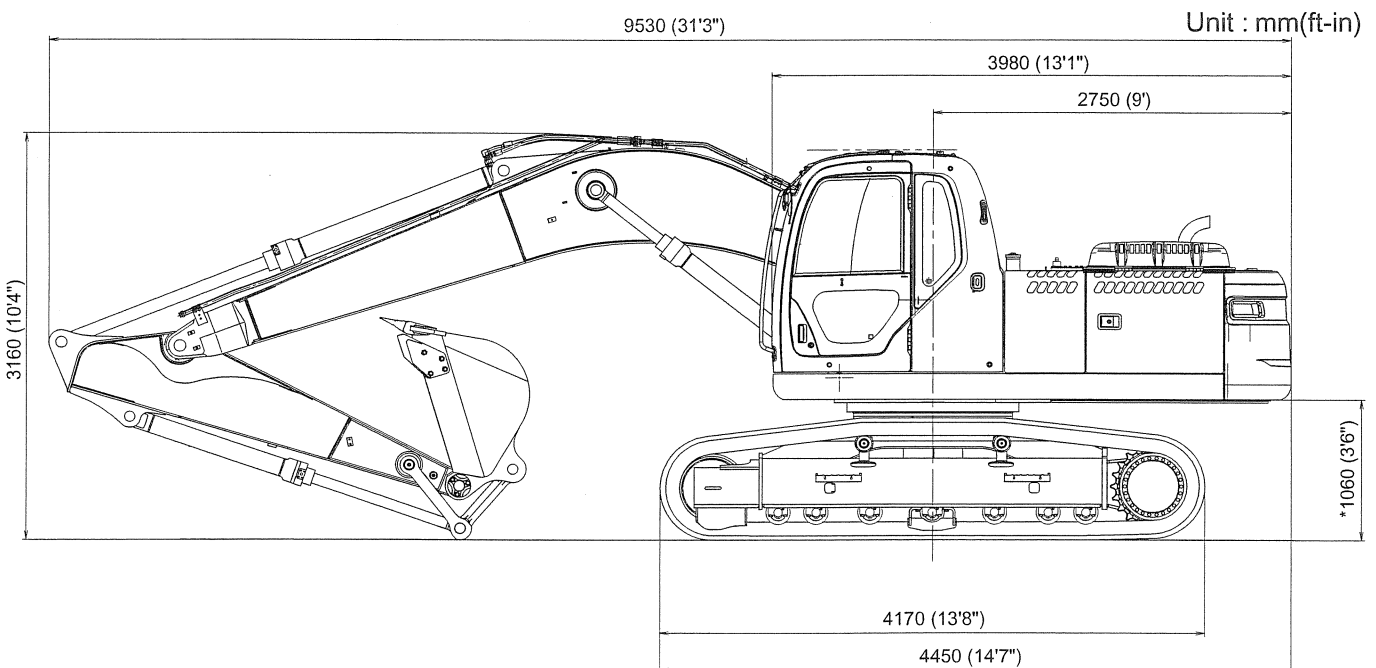

2.2.3 SK200-8/SK210LC-8 [5.65m (18ft-6in) Boom+3.5m (11ft-6in) Long Arm+0.70m³ (0.92cu·yd) Bucket Shoe]

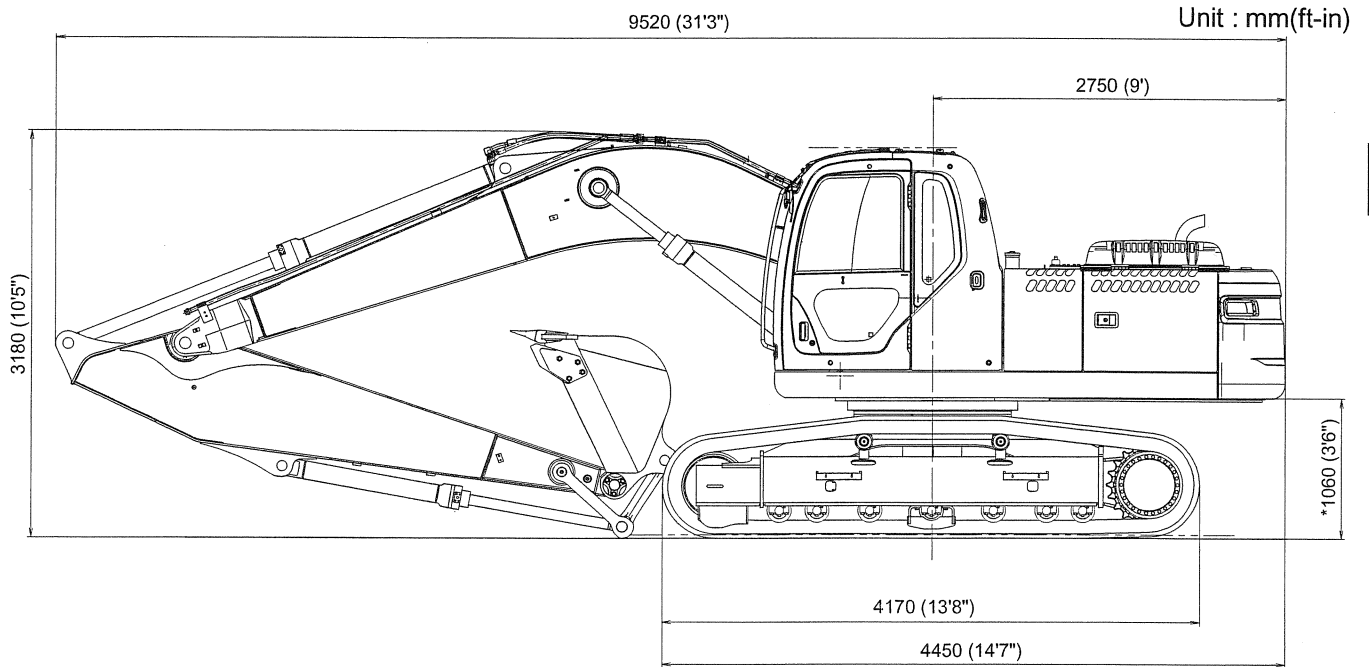

Note

Dimensions marked * do not include the height of the shoe lug.
 [] include LC specifications.

2. SPECIFICATIONS

2.3 WEIGHT OF COMPONENTS

Item	Model	Unit ; kg (lb)	
		SK200 - 8	SK210LC - 8
Machine complete		20,200 (44,500)	20,600 (45,400)
1. Upper frame assy (Assembly of following :)		9,500 (21,000)	←
1.1 Upper frame		1,770 (3,900)	←
1.2 Counter weight (Semi-weighted)		4,640 (10,230)	←
1.3 Cab		260 (570)	←
1.4 Engine		*540 (1,190)	←
1.5 Hydraulic oil tank		*150 (330)	←
1.6 Fuel tank		*110 (240)	←
1.7 Slewing motor (including reduction unit)		*210 (460)	←
1.8 Control valve		*230 (510)	←
1.9 Boom cylinder		*170 (375) × 2	←
1.10 Pin (for mounting boom)		70 (150)	←
1.11 Pump		*130 (290)	←
1.12 Radiator (including intercooler)		*90 (200)	←
2. Lower frame assy (Assembly of following :)		6,730 (14,840)	7,130 (15,720)
2.1 Lower frame		2,260 (4,980)	2,420 (5,340)
2.2 Slewing bearing		250 (550)	←
2.3 Travel motor (including reduction unit)		260 (570) × 2	←
2.4 Upper roller		20 (44) × 2	←
2.5 Lower roller		30 (66) × 14	30 (66) × 16
2.6 Front idler		110 (240) × 2	←
2.7 Idler adjuster		100 (220) × 2	←
2.8 Sprocket		50 (110) × 2	←
2.9 Swivel joint		*30 (66)	←
2.10 Track link with 600mm (23.6in) shoes assy		1,260 (2,780) × 2	1,350 (2,980) × 2
Track link with 700mm (27.6in) shoes assy		1,470 (3,240) × 2	1,560 (3,440) × 2
Track link with 800mm (31.5in) shoes assy		1,600 (3,530) × 2	1,700 (3,750) × 2
2.10.1 Track link assy		510 (1,120) × 2	540 (1,190) × 2
3. Attachment (Assembly of following / STD :)		3,420 (7,540)	←
{5.65m (18ft-6in) Boom + 2.94m (9ft-8in) Arm + 0.80m ³ (1cu•yd) Bucket}			
3.1 Bucket assy (STD)		640 (1,410)	←
3.2 STD Arm assy (Assembly of following :)		1,050 (2,315)	←
3.2.1 STD Arm		660 (1,455)	←
3.2.2 Bucket cylinder		*140 (310)	←
3.2.3 Idler link		20 (44) × 2	←
3.2.4 Bucket link		90 (198)	←
3.2.5 Pin (2pcs. for mounting bucket cylinder / 2pcs. for mounting bucket)		100 (220)	←
3.3 Boom assy (Assembly of following :)		1,730 (3,815)	←
3.3.1 Boom		1,310 (2,890)	←
3.3.2 Arm cylinder		*255 (560)	←
3.3.3 Pin (Mounting arm • Mounting arm cylinder)		80 (180)	←

2. SPECIFICATIONS

Item	Model	Unit ; kg (lb)	
		SK200 - 8	SK210LC - 8
4. Lubricant and water (Assembly of following :)		550 (1,210)	←
4.1 Hydraulic oil		200 (440)	←
4.2 Engine oil		20 (44)	←
4.3 Fuel		310 (680)	←
4.4 Water		20 (44)	←

Note

Marks * show dry weight.

2. SPECIFICATIONS

2.4 TRANSPORTATION

2.4.1 OVERALL DIMENSIONS OF MACHINE ON A TRAILER

(1) 5.65m (18ft-6in) Boom+2.94m (9ft-8in) Arm+0.80m³ (1.05cu•yd) Bucket

Item	Model	SK200-8	SK200LC-8
Width 600mm (23.6in) shoes		2,800 (9ft-2in)	2,990 (9ft-10in)
Weight		20,200kg (44,500 lbs)	20,600kg (45,400 lbs)

Unit : mm (ft-in)

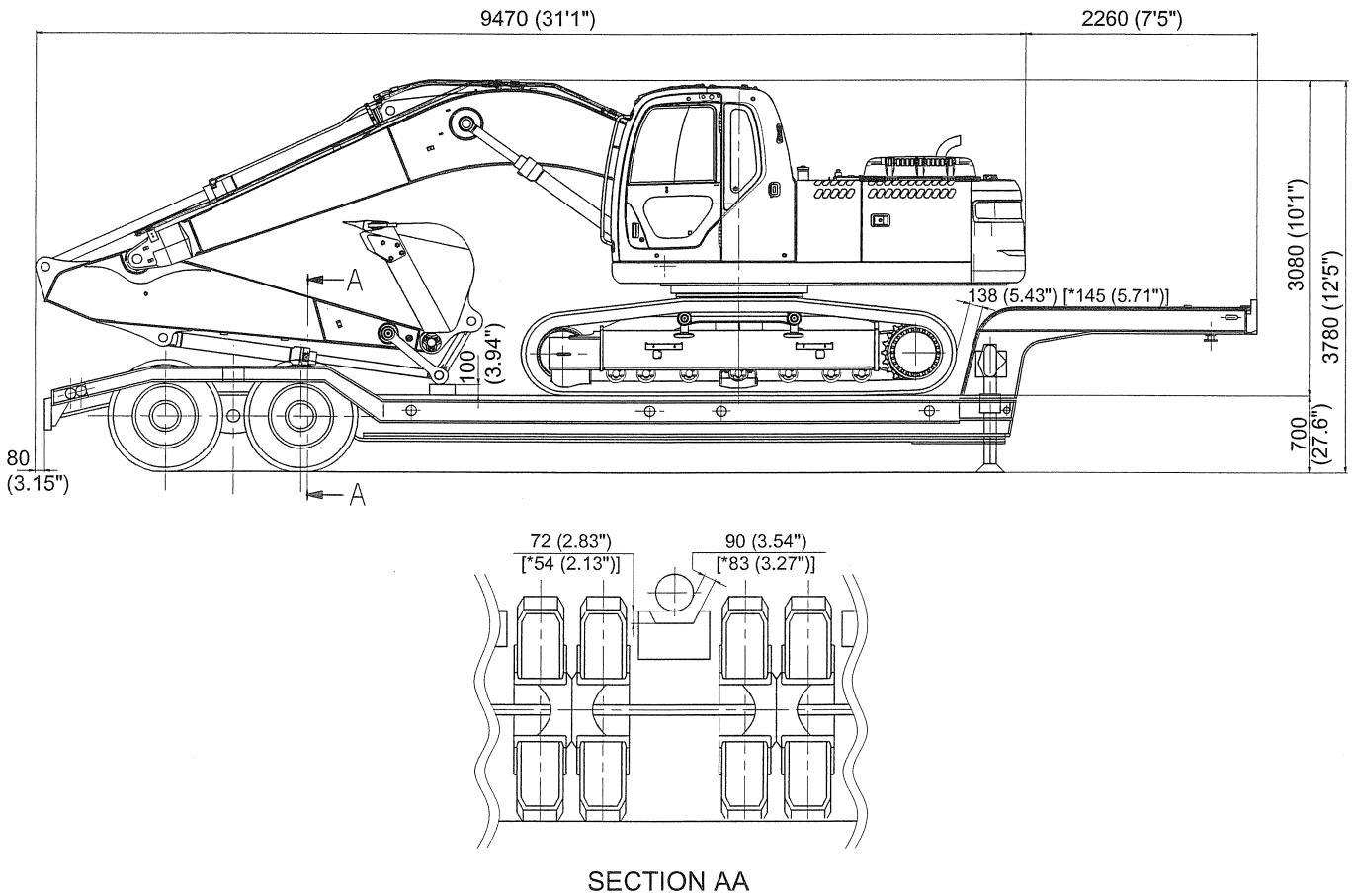

SECTION AA

Note

* marks indicate LC specifications.

Thank you so much for reading.
Please click the “Buy Now!”
button below to download the
complete manual.



After you pay.

You can download the most
perfect and complete manual in
the world immediately.

Our support email:

ebooklibonline@outlook.com