

KOBELCO

SERVICE MANUAL

HYDRAULIC EXCAVATOR

SK200 IV

SK200LC IV

Applicable: SK200 IV YNU0201~
Applicable: SK200LC IV YQU2001~
S5YQU0005E-00 11/03

SERVICE/SHOP MANUAL

SK200 IV
SK200LC IV

HYDRAULIC EXCAVATOR

Section 1 - SPECIFICATION

Section 2 - MAINTENANCE

Section 3 - SYSTEM

Section 4 - DISASSEMBLY

Section 5 - TROUBLESHOOTING

Section 6 - ENGINE

Section 7 - MISCELLANEOUS

Specifications

Maintenance

System

Disassembling

Troubleshooting

E/G

Misc.

KOBELCO

Book Code No. S5YQU0005E-00

SHOP MANUAL

model

YNU · YQU

TABLE OF CONTENTS

1. SPECIFICATION
2. OPERATION AND CONTROLS (Refer to Operators Manual)
3. LOCATION AND WEIGHT OF COMPONENTS
4. MAINTENANCE STANDARDS AND TEST PROCEDURES
5.
6. PREVENTIVE MAINTENANCE (Refer to Operators Manual)
7. WORKING STANDARDS
8. STANDARD MAN-HOUR TABLE

YQU01

YQU03

YQU04

YQU07

YQU08

○How to Index each Shop Manual Section
The GENERAL of this shop manual consists of 8 headings as shown above. Each section can be easily referred to by indexes appended to the margin of the page as indicated on the right. Please use the indexes for speedy reference.

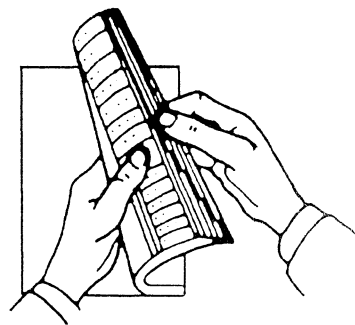

KOBELCO

GENERAL

YNU
YQU

List of Shop Manual GENERAL Section

Index No.	Title	Book Code No.		
		Distribution Year - Month		
YQU01	SPECIFICATION	S5YQU0105E 1995-01		
—	OPERATION	LLUK955001OM Refer to Operators manual		
YQU03	LOCATION AND WEIGHT OF COMPONENTS	S5YQU0305E 1995-01		
YQU04	MAINTENANCE STANDARDS AND TEST PROCEDURES	S5YQU0405E 1995-01		
—	PREVENTIVE MAINTENANCE	LLUK955001OM Refer to Operators manual		
YQU07	WORKING STANDARDS	S5YQU0705E 1995-01		
	Applicable Machines	YNU0201~ YQU2001~		

Book code No. S5 YQU01 05E

KOBELCO

SHOP MANUAL

YNU · YQU

YQU01

SPECIFICATION

TABLE OF CONTENTS

1. LOCATION OF COMPONENTS	1
2. GENERAL DIMENSIONS	2
3. SPECIFICATIONS AND PERFORMANCE	4
4. TYPE OF SHOES	5
5. TYPE AND COMBINATION OF ATTACHMENTS ...	6
6. WORKING RANGES OF ATTACHMENTS	8
7. LIFTING-UP ABILITY DIAGRAM	10
8. ENGINE SPECIFICATIONS	17

KOBELCO CONSTRUCTION MACHINERY(U.S.A.) INC.

Applicable Machines

YNU0201~

YQU2001~

Revision	Date of Issue	Remarks
First edition	January, 1995	S5YQU0105E K

1. LOCATION OF COMPONENTS

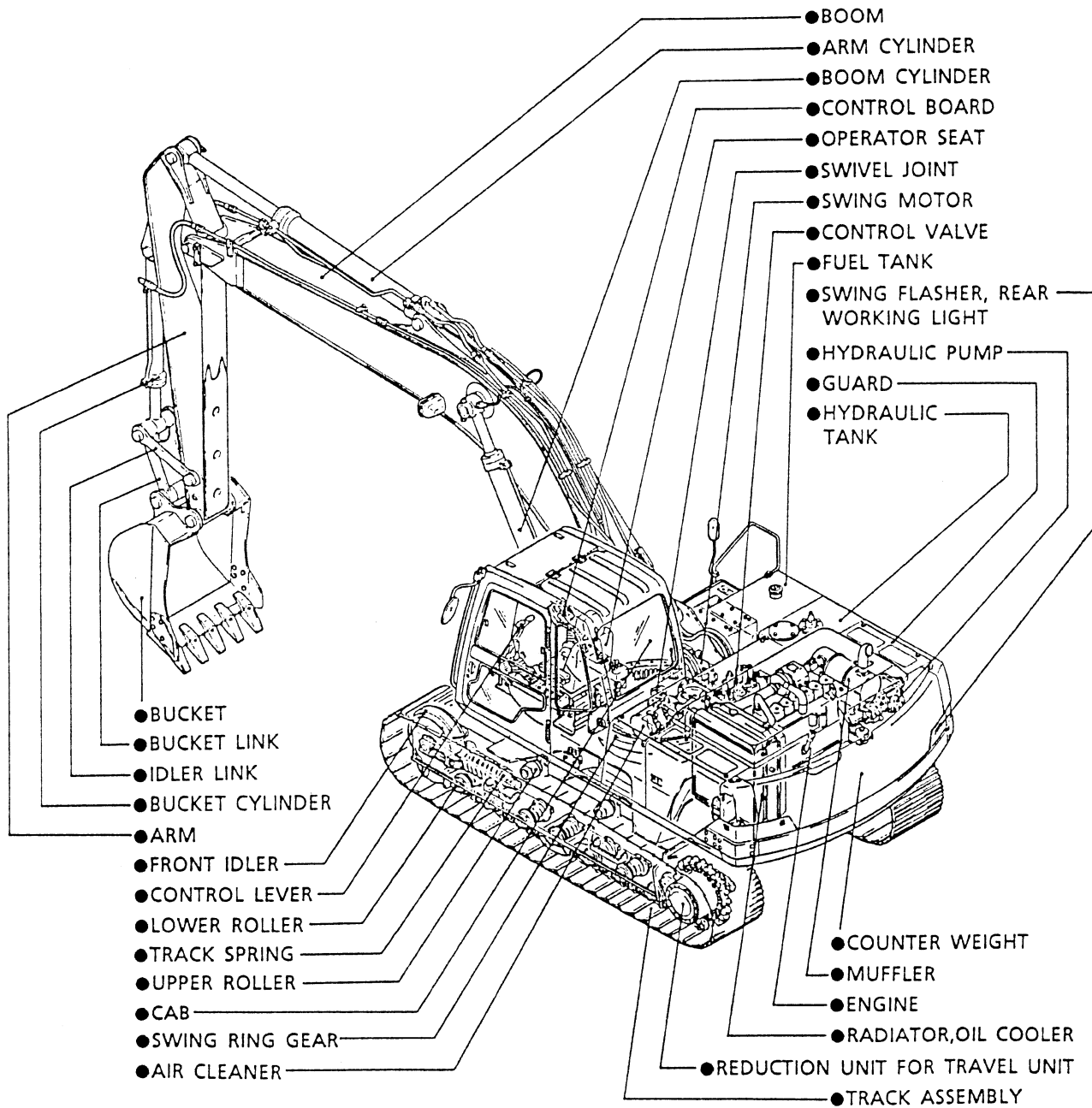

2. GENERAL DIMENSIONS

■ YQU

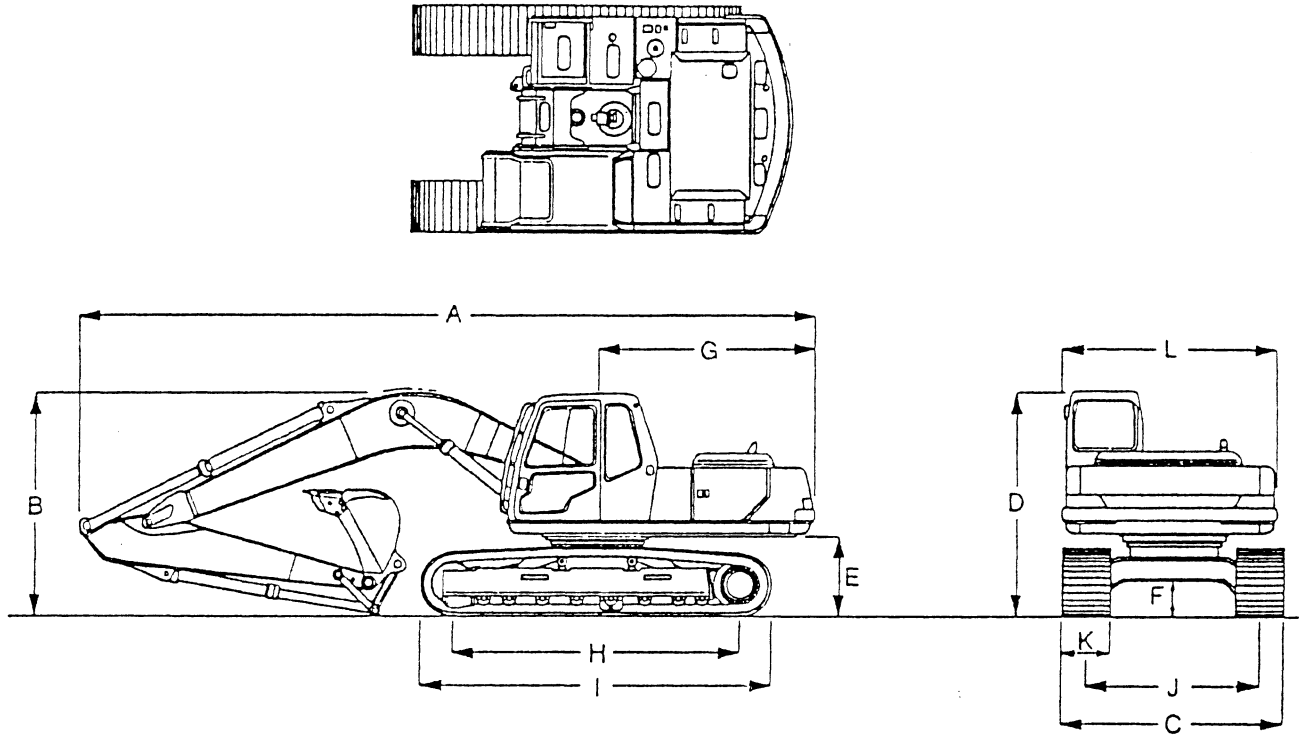

Unit: m (ft·in)

Arm length	2.4m (7' 10")	2.94m (9' 8")	3.3m (10' 10")
A Overall length	9.38 (30' 9")	9.32 (30' 7")	9.31 (30' 7")
B Overall height (to top of boom)	3.05 (10' 0")	2.91 (9' 8")	2.86 (9' 5")
C Overall width	3.19 (10' 6")	3.19 (10' 6")	3.19 (10' 6")
D Overall height (to top of cab)	2.89 (9' 6")	2.89 (9' 6")	2.89 (9' 6")
※E Ground clearance of rear end	1.055 (3' 6")	1.055 (3' 6")	1.055 (3' 6")
※F Ground clearance	0.465 (18.3")	0.465 (18.3")	0.465 (18.3")
G Tall swing radius	2.70 (8' 10")	2.70 (8' 10")	2.70 (8' 10")
H Tumbler distance	3.66 (12' 0")	3.66 (12' 0")	3.66 (12' 0")
I Overall length of crawler	4.465 (14' 8")	4.465 (14' 8")	4.465 (14' 8")
J Track gauge	2.39 (7' 10")	2.39 (7' 10")	2.39 (7' 10")
K Shoe width	800mm (31.5")	800mm (31.5")	800mm (31.5")
L Overall width of upper structure	2.72 (8' 11")	2.72 (8' 11")	2.72 (8' 11")

● The figures marks ※ in the illustration do not include the shoe lug (25mm) [0.98"].

■ YNU

Unit : m (ft · in)

Arm length		2.4m (7' 10")	2.94m (9' 8")	3.3m (10' 10")
A Overall length		9.38 (30' 9")	9.32 (30' 7")	9.31 (30' 7")
B Overall height (to top of boom)		3.06 (10' 0")	2.91 (9' 8")	2.86 (9' 5")
C Overall width		2.80 (9' 2")	2.80 (9' 2")	2.80 (9' 2")
D Overall height (to top of cab)		2.89 (9' 6")	2.89 (9' 6")	2.89 (9' 6")
※E Ground clearance of rear end		1.055 (3' 6")	1.055 (3' 6")	1.055 (3' 6")
※F Ground clearance		0.465 (18.3")	0.465 (18.3")	0.465 (18.3")
G Tall swing radius		2.70 (8' 10")	2.70 (8' 10")	2.70 (8' 10")
H Tumbler distance		3.28 (10' 9")	3.28 (10' 9")	3.28 (10' 9")
I Overall length of crawler		4.90 (16' 1")	4.90 (16' 1")	4.90 (16' 1")
J Track gauge		2.20 (7' 3")	2.20 (7' 3")	2.20 (7' 3")
K Shoe width		600mm (24.0")	600mm (24.0")	600mm (24.0")
L Overall width of upper structure		2.72 (8' 11")	2.72 (8' 11")	2.72 (8' 11")

● The figures marked ※ in the illustration do not include the shoe lug (25mm) [0.98"].

■ OVERALL WIDTH OF CRAWLER AND WIDTH OF TRACK SHOE

○ Standard
△ Option

	K	C	AMERICA				EUROPE							
	Width of track shoe mm (in)	Overall width of crawler mm (in)	CANADA	KAI	CHILE	COLUMBIA	U.K.	NETH.	BELGIUM	PORTUGAL	GERMANY	FRANCE	AUSTRIA	SWITZERLAND
YNU	600 (24")	2,800 (9' 2")			○	○				○	○		○	○
	700 (28")	2,900 (9' 6")			○	○	○	△	○	△				
	800 (32")	3,000 (9' 10")			○	○		○	△					
YQU	600 (24")	2,990 (9' 10")								○	○		○	○
	700 (28")	3,090 (10' 2")					○		○					
	800 (32")	3,190 (10' 6")	○	○	○			○						

3. SPECIFICATIONS AND PERFORMANCE

■ SPEED AND CLIMBING ABILITY

Item	Model	YNU · YQU
Swing speed		13rpm
Travel speed		7 / 4km / h (4.3 / 2.5 mph)
Gradeability		35° (70%)

■ ENGINE

Model	Cummins 6 BT5.9		
Type	Water-cooled 4-cycle, direct injection type with exhaust turbo supercharger		
Number of cylinder - Bore × Stroke	6 - 102mm(4.02in) × 120mm(4.72in)		
Total displacement	5,880c.c. (359cuin)		
Rated output power/revolution	JISD 1005 NET	※	140 PS/2,200rpm
	SAE J 1349 NET	※	138 PS/2,200rpm
	DIN 6270 NET	※	140 PS/2,200rpm
Maximum torque/revolution	JISD 1005 NET		53 kgf·m / 1,600rpm
	SAE J 1349 NET		388 ft·lbs / 1,600rpm
	DIN 6270 NET		53 kgf·m / 1,600rpm

Note : Mark ※ indicates that mounted for air cleaner, alternator and no muffler.

■ HYDRAULIC COMPONENTS

Hydraulic pump	Double-pump variable displacement, axial piston + gear pump
Hydraulic motor (swing)	Axial piston motor
Hydraulic motor (travel)	Axial piston motor
Control valve	5-spool multiple control valve + 1-spool control valve (swing)
Cylinders (boom, arm, and bucket)	Double acting cylinder
Return filter	Safety valve containing filter type
Oil cooler	Air-cooled type

■ WEIGHT

Item	Model	YNU			YQU		
Fully-equipped weight		19,600(43,200)	19,810(43,700)	20,100(44,300)	20,200(44,400)	20,590(45,400)	20,900(45,900)
Upper machinery		9,200 (20,300)	←	←	←	←	←
Lower machinery with grouser shoe	600 (24')	7,100 (15,600)	←	←	7,700 (16,800)	←	←
	700 (28')	←	7,410 (16,300)	←	←	7,990 (17,600)	←
	800 (32')	←	←	7,700 (17,000)	←	←	8,300 (18,200)
5.6m (18' 4") boom + 2.94m (9' 8") arm + 0.81m ³ (1.06 cuyd) bucket		3,300 (7,300)	←	←	←	←	←

4. TYPE OF SHOES

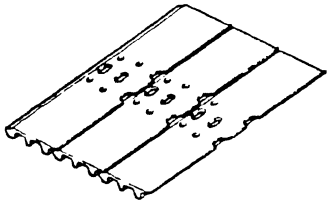
Shape	Model	Width of track shoe [mm(ft-in)]	Overall width of crawler [mm(ft-in)]	Ground pressure [kg/cm ² (psi)]
Grouser(equal height)  <small>YNK-6-7</small>	YNU 45 link	600 (24")	2,800 (9' 2")	0.45(6.39)
		700 (28")	2,900 (9' 6")	0.39(5.54)
		800 (32")	3,000 (9' 10")	0.35(4.96)
		900 (36")	3,190 (10' 6")	0.31(4.40)
	YQU 49 link	600 (24")	2,990 (9' 9")	0.43(6.11)
		700 (28")	3,090 (10' 2")	0.36(5.11)
		800 (32")	3,190 (10' 6")	0.33(4.69)

- NOTE :
- 700mm (28"), 800mm (32") shoe and 900mm (36") shoe come in three types, wet land, paved road and soft land. Do not use these shoes at sites which contain large stones, or other obstructions.
 - Operating machines equipped with special shoes on sites which contain items such as large rocks can bend shoes, cause shoe bolts to loosen, or damage the lower frame (links, rollers, etc.).

Thank you so much for reading.
Please click the “Buy Now!”
button below to download the
complete manual.



After you pay.

You can download the most
perfect and complete manual in
the world immediately.

Our support email:

ebooklibonline@outlook.com