

**KOBELCO**

**SERVICEMAN'S HANDBOOK**

**HYDRAULIC EXCAVATOR  
MARK III SERIES**

## APPLIED MACHINES

This serviceman's handbook provides essential information regarding the following models of excavator.

**SK 60**

**SK 100**

**SK 120**

**SK 120<sub>LC</sub>**

**SK 200**

**SK 200<sub>LC</sub>**

**SK 220**

**SK 220<sub>LC</sub>**

### PREFACE

This serviceman's handbook for the KOBELCO hydraulic excavator provides maintenance and repair personnel with basic information concerning routine maintenance and repair of the KOBELCO machine.

This handbook is compiled for the user's convenience using extracts mainly from the Operators and Shop Manuals.

For inspection and maintenance of the machine in the field, use this handbook as a reference to improve your work efficiency.

# DIMENSIONS

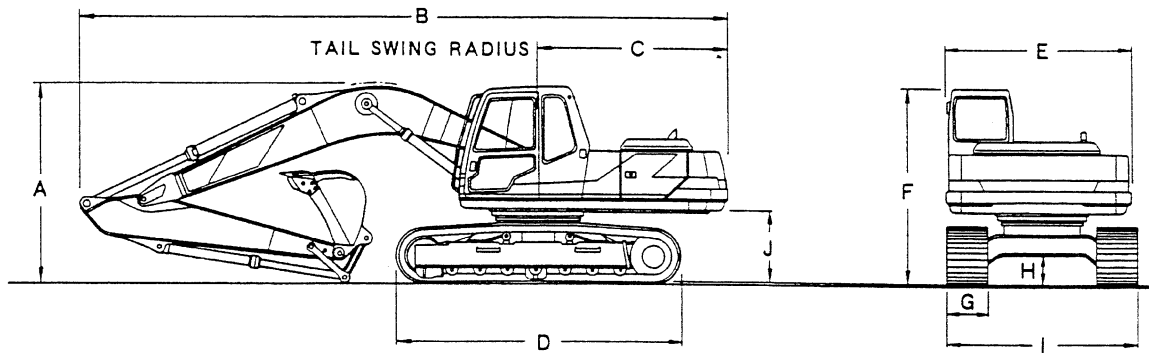

MODEL	DIMENSIONS										Unit: (ft-in)
	A	B	C	D	E	F	G	H	I	J	ARM
SK60	2,950 (9' 8.1")	6,005 (19' 8.4")					400 (15.7")		2,100 (6' 10.6")		2,150 (7' 11")
	2,610 (8' 6.7")	6,020 (19' 9.0")	(R1.700) (R5' 6.9")	2,770 (9' 1.0")	2,160 (7' 1.0")	2,595 (8' 6.1")	500 (19.6")	380 (1' 2.9")	2,200 (7' 2.6")	770 (2' 6.3")	1,730 (5' 8")
	2,815 (9' 2.8")	6,020 (19' 9.0")					600 (23.5")		2,300 (7' 6.5")		1,730 + 450 (5' 8" + 1' 6")
SK100	2,570 (8' 5.2")	7,240 (23' 9.0")					500 (19.6")		2,490 (8' 2.0")		2,270 (7' 5")
	2,570 (8' 5.2")	7,290 (23' 11.0")	R2.130	3,320 (10' 11.0")	2,430 (7' 12.0")	2,725 (8' 11.2")	600 (23.6")	455 (1' 6.0")	2,590 (8' 6.0")	900 (2' 11.4")	1,900 (6' 3")
	2,900 (9' 6.1")	7,180 (23' 6.6")	(R7' 0")				700 (27.6")		2,690 (8' 10.0")		2,770 (9' 1")
	2,835 (9' 3.6")	7,195 (23' 7.2")					800 (31.5")		2,790 (9' 2.0")		2,270 + 600 (7' 5" + 1' 11")
SK120 SK120LC	2,595 (8' 6.1")	7,585 (24' 10.6")		3,490 (11' 5.4")			500 (19.6")		2,490 (8' 2.0")		2,500 (8' 2")
	2,650 (8' 8.3")	7,595 (24' 11.0")	R2.150		2,430 (7' 11.6")	2,725 (8' 11.2")	600 (23.6")	455 (1' 6.0")	2,590 (8' 6.0")	900 (2' 11.4")	2,100 (6' 11")
	2,035 (6' 8.1")	7,550 (24' 9.2")	(R7' 0.6")	3,740 (12' 3.2")			700 (27.6")		2,690 (8' 10.0")		3,000 (9' 10")
	3,065 (10' 0.6")	7,530 (24' 8.4")		[LC-type]			800 (31.5")		2,790 (9' 2.0")		2,500 + 1,000 (8' 2" + 3' 3")
SK200 SK200LC	3,060 (10' 0.4")	9,380 (30' 9.3")					600 (23.6")		2,800 (9' 2.2")		2,400 (7' 11")
	2,910 (9' 6.5")	9,320 (30' 7.0")		4,070 (13' 4.2")			800 (31.5")	465 (1' 6.3")	3,000 (9' 10.1")	1,055 (3' 5.5")	2,940 (9' 7")
	2,860 (9' 4.6")	9,310 (30' 6.5")	R2.700 (R8' 10.3")		2,720 (8' 11.0")	2,890 (9' 5.7")	800 (31.5")		3,190 (10' 5.6")		3,300 (10' 10")
	3,730 (12' 2.8")	9,210 (30' 2.6")		4,450 (14' 7.2")			900 (35.4")		3,190 (10' 5.6")		2,400 + 1,500 (7' 11" + 4' 11")
	3,450 (11' 3.8")	9,310 (30' 6.5")							3,190 (10' 5.6")		2,940 + 1,500 (9' 8" + 4' 11")
SK220 SK220LC	3,210 (10' 6.3")	10,070 (33' 0.4")		4,350 (14' 3.2")			600 (23.6")		2,990 (9' 9.7")		
							700 (27.6")	480 (1' 6.7")	3,090 (10' 1.6")		2,500 (8' 2")
			R2.850 (R9' 4.2")		2,830 (9' 3.4")	2,920 (9' 7.0")	800 (31.5")		3,190 (10' 5.6")	1,080 (3' 6.5")	
							500 (23.6")		3,190 (10' 5.6")		2,980 (9' 9")
	3,070 (10' 0.8")	9,980 (32' 9.0")		4,650 (15' 3.0")			700 (27.6")	465 (1' 6.3")	3,290 (10' 9.5")		
							800 (31.5")		3,390 (11' 1.4")		3,660 (12' 0")

(CONTENTS)

MACHINE SPECIFICATIONS .....	1
COMPONENTS SPECIFICATIONS .....	6
PERFORMANCE DATA .....	8
NOISE LEVEL DATA .....	9
WEIGHT OF COMPONENTS (DRY WEIGHT) .....	10
LUBRICATION VOLUME CHART .....	14
PERFORMANCE INSPECTION STANDARD .....	24
HYDRAULIC CIRCUITS AND COMPONENTS .....	62
PQ CURVE PUMP .....	68
DIMENSIONS FOR ATTACHMENT .....	73
MAINTENANCE STANDARDS .....	81
TRAVEL MAINTENANCE STANDARDS .....	94
HYDRAULIC CYLINDER .....	116
ELECTRIC SYSTEM DIAGRAM .....	120
WORKING RANGE OF ATTACHMENTS	
SK60 .....	128
SK100 • SK120 • SK120LC .....	130
SK200 • SK200LC .....	135
SK220 • SK220LC .....	138
LIFTING CAPACITY	
SK60 .....	140
SK100 • SK120 • SK120LC .....	141
SK200 • SK200LC .....	143
SK220 • SK220LC .....	145
COMPONENTS	
SK60 .....	147
SK100 • SK120 • SK120LC .....	165
SK200 • SK200LC .....	188
SK220 • SK220LC .....	208

## MACHINE SPECIFICATIONS

Item		Model	SK60		
Std. bucket capacity		M <sup>3</sup> (cuyd)	0.25 (0.33)		
Range of bucket		M <sup>3</sup> (cuyd)	0.1~0.3 (0.13~0.39)		
Overall weight		ton (lbs)	6.4 (400 mm shoe) [14,110 (16' shoe)]		
Performance	Swing speed		rpm	13	
	Travel speed		km/h(M/h)	3.7/5.5 (2.3/3.4)	
	Gradeability		%	70 (35°)	
	Digging Force	Bucket	ton (lbs)	4.8 (10,580)	
		Arm	ton (lbs)	3.7 (8,160)	
		Arm length	mm (in)	1,730 (5' 8.1" )	
	Tractive force		ton (lbs)	5.2 (11,460)	
General dimensions	Arm length		mm (in)	1,730 (5' 8.1" ) 2,150 (7' 0.6" )	
	Overall length		mm (in)	6,020 (19' 9.0" ) 6,005 (19' 8.4" )	
	Overall width		mm (in)	2,180 (7' 1.8" ) 2,180 (7' 1.8" )	
	Overall height		mm (in)	2,610 (8' 6.7" ) 2,610 (8' 6.7" )	
	Ground clearance of undercarriage		mm (in)	380 (15" ) 380 (15" )	
Track	Overall length of crawler		mm (in)	2,770 (9' 1.0" )	
	Center distance of tumblers		mm (in)	2,160 (7' 1.0" )	
	Center distance of crawler		mm (in)	1,700 (5' 6.9" )	
	Width of track shoe	mm, kg/cm (in, psi)	Grouser (Equal height)	400/0.34 (16" / 4.83)	
				200/0.27 (20" / 3.83)	
	Ground pressure	(in, psi)	Flat	600/0.23 (24" / 3.27)	
				400/0.34 (16" / 4.83)	
Triangle			600/0.23 (24" / 3.27) 700/0.20 (27.6" / 2.84)		
Engine	Maker/Model		ISUZU 4JB1		
	Type		Water-cooled 4-cycle, direct injection type		
	Rated output power		ps/rpm	75/2,200	
	Maximum torque		kgm/rpm	18/1,800	
	Number of cylinder - Bore × Stroke		mm (in)	4 - 93 × 102 (4 - 3.66" × 4.02" )	
	Total displacement		cc (cuin)	2,771 (169)	
	Fuel consumption		g/psh	170	
	Dry weight		kg (lbs)	240 (530)	
	Fuel tank capacity		L (gal)	130 (24)	

Item	Model	SK100				
Std. bucket capacity	M <sup>3</sup> (cuyd)	0.4 (0.52)				
Range of bucket	M <sup>3</sup> (cuyd)	0.15~0.45 (0.20~0.59)				
Overall weight	ton (lbs)	10.5 (500 mm shoe) [23,150 (20" shoe)]				
Performance	Swing speed	rpm	12.7			
	Travel speed	km/h(M/h)	1ST SPEED 4 (2.4) 2ND SPEED 7 (4.3)			
	Gradeability	%	70 (35°)			
	Digging Force	Bucket	ton (lbs)	7.5 (16,530)		
		Arm	ton (lbs)	6.4 (14,110)	5.6 (12,345)	4.9 (10,800)
		Arm length	mm (in)	1,900 (6' 2.8")	2,270 (7' 5.3")	2,770 (9' 1.0")
	Tractive force	ton (lbs)	4.5/8.9 (9,920/19,620)			
General dimensions	Arm length	mm (in)	1,900 (6' 2.8")	2,270 (7' 5.3")	2,770 (9' 1.0")	
	Overall length	mm (in)	7,290 (23' 11.0")	7,240 (23' 9.0")	7,180 (23' 6.6")	
	Overall width	mm (in)	2,490 (8' 2.0")	2,490 (8' 2.0")	2,490 (8' 2.0")	
	Overall height	mm (in)	2,725 (8' 11.2")	2,725 (8' 11.2")	2,900 (9' 6.1")	
	Ground clearance of undercarriage	mm (in)	455 (18)	455 (18")	455 (18")	
Track	Overall length of crawler	mm (in)	3,320 (10' 10.7")			
	Center distance of tumblers	mm (in)	1,990 (6' 6.3")			
	Center distance of crawler	mm (in)	2,610 (8' 6.7")			
	Width of track shoe	mm, kg/cm (in, psi)	Grouser (Equal height)	500 / 0.36 (20" / 5.12)		
				600 / 0.302 (24" / 4.27)		
				700 / 0.26 (27.6" / 3.70)		
Ground pressure		Flat	500 / 0.36 (20" / 5.12)			
		Triangle	800 / 0.23 (32" / 3.27)			
Engine	Maker/Model		ISUZU 4BD1			
	Type		4-cycie, water-cooled direct injection type diesel			
	Rated output power	ps/rpm	76/2,300			
	Maximum torque	kgm/rpm	24/1,600			
	Number of cylinder - Bore × Stroke	mm (in)	4 - 102 × 118 (4 - 4.0" × 4.6")			
	Total displacement	cc (cuin)	3,856 (235)			
	Fuel consumption	g/psh	173 ± 5			
	Dry weight	kg (lbs)	325 (715)			
Fuel tank capacity	L (gal)	250 (66)				

Item		Model	SK120		SK120LC		
Std. bucket capacity		M <sup>3</sup> (cuyd)	0.45 (0.52)				
Range of bucket		M <sup>3</sup> (cuyd)	0.3~0.6 (0.39~0.78)				
Overall weight		ton (lbs)	11.5 (500 mm shoe) [25,350 (20" shoe)]		11.7 (500 mm shoe) [25,790 (20" shoe)]		
Performance	Swing speed		rpm 12.7				
	Travel speed		km/h(M/h) 1ST SPEED 4 (2.5) 2ND SPEED 7 (4.3)				
	Gradeability		% 70 (35°)				
	Digging Force	Bucket	ton (lbs)	7.7 (16,975)			
		Arm	ton (lbs)	6.8 (14,990)	6.1 (13,450)	5.4 (11,900)	
		Arm length	mm (in)	2,100 (6' 10.6" )	2,500 (8' 2.4" )	3,100 (10' 2.0" )	
Tractive force		ton (lbs)	4.9/9.3 (10,800/20,500)				
General dimensions	Arm length		mm (in)	2,100 (6' 10.6" )	2,500 (8' 2.4" )	3,100 (10' 2.0" )	
	Overall length		mm (in)	7,585 (24' 10.6" )	7,595 (24' 11.0" )	7,550 (24' 9.2" )	
	Overall width		mm (in)	2,490 (8' 2.0" )	2,490 (8' 2.0" )	2,490 (8' 2.0" )	
	Overall height		mm (in)	2,725 (8' 11.2" )	2,725 (8' 11.2" )	2,725 (8' 11.2" )	
	Ground clearance of undercarriage		mm (in)	455 (18" )	455 (18" )	455 (18" )	
Track	Overall length of crawler		mm (in)	3,490 (11' 5.3" )		3,740 (12' 3.2" )	
	Center distance of tumblers		mm (in)	1,990 (6' 6.3" )			
	Center distance of crawler		mm (in)	2,780 (9' 1.4" )		3,035 (9' 11.4" )	
	Width of track shoe	/	mm, kg/cm (in, psi)	Grouser (Equal height)	500 / 0.38 (20" / 5.40)	Grouser (Equal height)	500 / 0.36 (20" / 5.12)
					600 / 0.32 (24" / 4.55)		600 / 0.30 (24" / 4.27)
	700 / 0.28 (27.6" / 3.98)	700 / 0.26 (27.6" / 3.70)					
	Ground pressure	/		Flat	500 / 0.38 (20" / 5.40)	Flat	500 / 0.36 (20" / 5.12)
					Triangle		800 / 0.24 (32" / 3.41)
Maker/Model		ISUZU 4BD1T					
Type		4-cycle, water-cooled direct injection type with turbo charger					
Rated output power		ps/rpm	85/2,150				
Maximum torque		kgm/rpm	30/1,600				
Number of cylinder - Bore x Stroke		mm (in)	4 - 102 x 118 (4 - 4.0" x 4.64" )				
Total displacement		cc (cuin)	3,856 (235)				
Fuel consumption		g/psh	165 ± 5				
Dry weight		kg (lbs)	350 (770)				
Fuel tank capacity		L (gal)	250 (66)				
Engine							

200 SK200LC

Item		Model	SK200			SK200LC			
Std. bucket capacity		M <sup>3</sup> (cuyd)	0.7 (0.92)						
Range of bucket		M <sup>3</sup> (cuyd)	0.45~1.1 (0.59~1.44)						
Overall weight		ton (lbs)	18.7 (600 mm shoe) [41,220 (24' shoe)]			19.5 (600 mm shoe) [42,990 (24' shoe)]			
Performance	Swing speed		rpm		13				
	Travel speed		km/h(M/h)		1ST SPEED 4 (2.5) 2ND SPEED 7 (4.3)				
	Gradeability		%		70 (35°)				
	Digging Force	Bucket	ton (lbs)	25,130 (11.4)					
		Arm	ton (lbs)	10.8 (23,810)		20,280 (9.2)		8.5 (18,740)	
		Arm length	mm (in)	2,400 (7' 10.4' )		2,940 (9' 7.7' )		3,300 (10' 9.9' )	
	Tractive force		ton (bls)	8.6/16.3 (18,960/35,930)					
General dimensions	Arm length		mm (in)	2,400 (7' 10.4' )	2,940 (9' 7.7' )	3,300 (10' 9.9' )	2,400 (7' 10.4' )	2,940 (9' 7.7' )	3,300 (10' 9.9' )
	Overall length		mm (in)	9,310 (30' 6.5' )	9,320 (30' 6.9' )	9,310 (30' 6.5' )	9,380 (30' 9.2' )	9,320 (30' 6.9' )	9,310 (30' 6.5' )
	Overall width		mm (in)	2,800 (9' 2.2' )	2,800 (9' 2.2' )	2,800 (9' 2.2' )	2,990 (9' 9.7' )	2,990 (9' 9.7' )	2,990 (9' 9.7' )
	Overall height		mm (in)	3,060 (10' 0.4' )	2,910 (9' 6.5' )	2,890 (9' 5.7' )	2,890 (9' 5.7' )	2,890 (9' 5.7' )	2,890 (9' 5.7' )
	Ground clearance of undercarriage		mm (in)	465 (18.3' )	465 (18.3' )	465 (18.3' )	465 (18.3' )	465 (18.3' )	465 (18.3' )
Track	Overall length of crawler		mm (in)	4,070 (13' 4.2' )			4,450 (14' 7.1' )		
	Center distance of tumblers		mm (in)	2,200 (7' 2.6' )			2,390 (7' 10.0' )		
	Center distance of crawler		mm (in)	3,280 (10' 9.1' )			3,660 (12' 0.1' )		
	Width of track shoe	mm, kg/cm	(Equal height)	Grouser	600 / 0.44 (24" / 6.26)		Grouser	600 / 0.41 (24" / 5.83)	
				Flat	800 / 0.34 (32" / 4.83)		Flat	800 / 0.32 (32" / 4.55)	
	Ground pressure	(in, psi)	Flat	Flat	600 / 0.45 (24" / 6.40)		Flat	600 / 0.42 (24" / 5.97)	
				Triangle	900 / 0.30 (36" / 4.27)		Triangle	900 / 0.28 (36" / 3.98)	
Maker/Model		MITSUBISHI 6D31T							
Type		Water-cooled 4-cycle, direct injection type with exhaust turbo supercharger							
Rated output power		ps/rpm	135/2,150						
Maximum torque		kgm/rpm	47/1,700						
Number of cylinder - Bore × Stroke		in (mm)	6 - 100 × 105 (6 - 3.9" × 4.13" )						
Total displacement		cc (cuin)	4,948 (767)						
Fuel consumption		g/psh	165						
Dry weight		kg (lbs)	440 (970)						
Fuel tank capacity		L (gal)	300 (79)						



Item		Model	SK220			SK220LC				
Std. bucket capacity		M <sup>3</sup> (cuyd)	0.9 (1.18)							
Range of bucket		M <sup>3</sup> (cuyd)	0.92~1.57 (0.7~1.2)							
Overall weight		ton (lbs)	22.9 (600 mm shoe) [50,485 (24" shoe)]			23.5 (600 mm shoe) [51,808 (24" shoe)]				
Performance	Swing speed		rpm	12						
	Travel speed		km/h(M/h)	1ST SPEED 4 (2.5) 2ND SPEED 7 (4.3)						
	Gradeability		%	70 (35°)						
	Digging Force	Bucket		ton (lbs)	13.8 (30,420)					
		Arm		ton (lbs)	12.9 (28,440)	10.9 (24,030)	10.5 (20,940)			
		Arm length		mm (in)	2,500 (8' 2.4" )	2,980 (9' 9.3" )	3,660 (12' 0.1" )			
Tractive force		ton (lbs)	18.9 (41,670)							
General dimensions	Arm length		mm (in)	2,500 (8' 2.4" )	2,980 (9' 9.3" )	3,660 (12' 0.1" )	2,500 (8' 2.4" )	2,980 (9' 9.3" )	3,660 (12' 0.1" )	
	Overall length		mm (in)	10,070 (33' 0.4" )	9,980 (32' 8.9" )	10,000 (32' 9.7" )	10,070 (33' 0.4" )	9,980 (32' 8.9" )	9,980 (32' 8.9" )	
	Overall width		mm (in)	2,990 (9' 9.7" )	2,990 (9' 9.7" )	2,990 (9' 9.7" )	3,190 (10' 5.6" )	3,190 (10' 5.6" )	3,190 (10' 5.6" )	
	Overall height		mm (in)	3,210 (10' 6.3" )	3,070 (10' 0.8" )	3,190 (10' 5.6" )	3,210 (10' 6.3" )	3,070 (10' 0.8" )	3,070 (10' 0.8" )	
	Ground clearance of undercarriage		mm (in)	480 (18.9" )	480 (18.9" )	480 (18.9" )	465 (18.3" )	465 (18.3" )	465 (18.3" )	
Track	Overall length of crawler		mm (in)	4,350 (14' 3.2" )			4,650 (15' 3.0" )			
	Center distance of tumblers		mm (in)	3,500 (11' 5.8" )			3,800 (12' 5.6" )			
	Center distance of crawler		mm (in)	2,390 (7' 10.1" )			2,590 (8' 5.9" )			
	Width of track shoe		mm. kg/cm (in. psi)	Grouser (Equal height)	600 / 0.51 (24" / 7.25)		Grouser (Equal height)	600 / 0.48 (24" / 6.83)		
	/				700 / 0.44 (27.6" / 6.26)			700 / 0.41 (27.6" / 5.83)		
	Ground pressure				800 / 0.39 (32" / 5.55)			800 / 0.37 (32" / 5.26)		
Engine	Maker/Model		MITSUBISHI 6D15-T							
	Type		Water-cooled 4- cycle, direct injection type with exhaust turbo supercharger							
	Rated output power		ps/rpm	165/2,150						
	Maximum torque		kgm/rpm	60/1,600						
	Number of cylinder - Bore × Stroke		in. psi	4 - 113 × 115 (6 - 4.45" × 4.53" )						
	Total displacement		cc (cuin)	6,919 (1,073)						
	Fuel consumption		g/psh	165						
	Dry weight		kg (lbs)	590 (1,300)						
	Fuel tank capacity		L (gal)	310 (81)						

COMPONENTS SPECIFICATIONS

Item	Model	SK60	SK100	SK120 - SK120LC	SK200 - SK200LC	SK220 - SK220LC
Hydraulic Pump	Maker		KAWASAKI HEAVY	KAWASAKI HEAVY	KAWASAKI HEAVY	KAWASAKI HEAVY
	Model		K3V63DT-120R-9C0B-1	K3V63DT-120R-9C0B	K3V112DT-123R-9C0B	K3V112DT-123R-9C1B
	Type	Variable Piston Pump	Variable Piston Pump	Variable Piston Pump	Variable Piston Pump	Variable Piston Pump
	Displacement	37.3 x 2 (2.27 x 2)	51.5 x 2 (3.14 x 2)	55.1 x 2 (3.36 x 2)	97.2 x 2 (5.93 x 2)	112.1 x 2 (6.84 x 2)
	Max. flow	82 (21.6)	118 x 2 (31.2 x 2)	118 x 2 (31.2 x 2)	208 x 2 (54.9 x 2)	240 x 2 (63.4 x 2)
	Pressure	210 (260 Travel boost pressure) [2985 (3700 Travel boost pressure)]	330 (350 Travel boost pressure) [4690 (4980 Travel boost pressure)]	300 (350 Travel boost pressure) [4265 (4980 Travel boost pressure)]	300 (350 Travel boost pressure) [4265 (4980 Travel boost pressure)]	300 (350 Travel boost pressure) [4265 (4980 Travel boost pressure)]
	Type	Gear pump	Gear pump	Gear pump	Gear pump	Gear pump
	Displacement	8.9 (0.54)	9.08 (0.55)	9.08 (0.55)	9.08 (0.55)	9.08 (0.55)
	Max. flow	20 (5.3)	17.4 (4.6)	17.4 (4.6)	19.4 (5.1)	19.4 (5.1)
	Pressure	35 (500)	50 (710)	50 (710)	50 (710)	50 (710)
Weight	55 (120)	85 + 1.6 (190 + 3.5)	85 + 1.6 (190 + 3.5)	125 + 1.6 (275 + 3.5)	125 + 1.6 (275 + 3.5)	
Control Valve	Maker		KAWASAKI HEAVY	KAWASAKI HEAVY	KAWASAKI HEAVY	KAWASAKI HEAVY
	Model		KMX131B-/23011	KMX131B-/23011	KMX151D-/23011	KMX151D-/23011
	Main relief valve pressure	210 (2990)	300 (4270)	300 (4270)	300 (335 Attach boost pressure) [4270 (4760 Attach boost pressure)]	300 (4270)
	Operation system	Remote control	Remote control	Remote control	Remote control	Remote control
	No. Weight	67 (5 ream) [150 (5 ream)]	95 (5 ream) 18 (1 ream) [209 (5 ream) 39 (1 ream)]	95 (5 ream) 18 (1 ream) [209 (5 ream) 39 (1 ream)]	127 (5 ream) 19 (1 ream) [280 (5 ream) 42 (1 ream)]	127 (5 ream) 19 (1 ream) [280 (5 ream) 42 (1 ream)]
	Maker	-	KAWASAKI HEAVY	KAWASAKI HEAVY	KAWASAKI HEAVY	KAWASAKI HEAVY
	Model	-	VBY-125	VBY-125	VBY-125A	VBY-125
	Max. pressure	-	350 (4980)	350 (4980)	350 (4980)	350 (4980)
	Max. flow	-	30 (8)	30 (8)	30 (8)	30 (8)
	Weight	-	13 (28)	13 (28)	13 (28)	13 (28)
Travel Lock Valve	Maker		KAWASAKI HEAVY	KAWASAKI HEAVY	KAWASAKI HEAVY	KAWASAKI HEAVY
	Model		KHV20G020/320	KHV20G020/320	KHV20G020/320	KHV20G020/320
	Max. pressure	-	350 (4980)	350 (4980)	350 (4980)	350 (4980)
	Relief pressure	-	320 (4550)	320 (4550)	320 (4550)	320 (4550)
	Rated flow	-	280 (74.0)	280 (74.0)	280 (74.0)	280 (74.0)
Weight	-	13 (28)	13 (28)	13 (28)	13 (28)	

Item	Model	SK60	SK100	SK120LC	SK200 • SK200LC	SK220 • SK220LC
Swing Motor	Maker	KAWASAKI HEAVY	KAWASAKI HEAVY	TOSHIBA MACHINE	KAWASAKI HEAVY	KAWASAKI HEAVY
	Model	M2X55A0B-10A-06M	M2X63A0B-11A-02	MFB80-023	M2X150A0B-10A-02	M2X170A0B-12A-01
	Type	Axial Plunger	Axial Plunger	Axial Plunger	Axial Plunger	Axial Plunger
	Displacement	56.1 (3.4) cc/rev (cuin/rev)	64 (3.9)	64 (3.9)	148.5 (9.0)	169.4 (10.3)
	Pressure	250 (3555) kg/cm <sup>2</sup> (psi)	220 (3130)	250 (3555)	250 (3555)	260 (3700)
	Reduction ratio	15.429	18.827	18.827	13.287	16.812
	Lubricating	4 (1.05) L (gal)	5.8 (1.53)	6.2 (1.63)	12 (3.17)	16 (4.22)
	Weight	100 (220) kg (lbs)	120 (265)	130 (285)	225 (495)	3450 (750)
	Maker	TEIJIN	TEIJIN	TEIJIN	NIPPON AIR BRAKE	NIPPON AIR BRAKE
	Model	GM08VL	GM17V3	GM17V3	MV150190Z	MV200130Z
Travel Motor	Type	Axial Plunger	Axial Plunger	Axial Plunger	Axial Plunger	Axial Plunger
	Displacement	39.8 (2.4) cc/rev (cuin/rev)	86.3 (5.3)	8603 (5.2)	87.5/156.6 (5.3/9.5)	110.2/197.7 (6.7/12.0)
	Pressure of brake valve	-	350 (4980) kg/cm <sup>2</sup> (psi)	350 (4980)	350 (4980)	350 (4980)
	Reduction unit ratio	62.4	39	39	40.67	39.0
	Lubricatio oil	1.7 (0.45) L (gal)	3 (0.80)	3 (0.80)	6 (1.58)	7.5 (1.98)
	Weight	90 (200) kg (lbs)	165 (360)	165 (360)	290 (640)	385 (850)
	Maker	KAWASAKI HEAVY	KAWASAKI HEAVY	KAWASAKI HEAVY	KAWASAKI HEAVY	KAWASAKI HEAVY
	Operating torque	6 (43) kg/cm (ft./lbs)	6 (43)	6 (43)	6 (43)	6 (43)
	Angle of operate	At Single Operate	At Single Operate	At Single Operate	At Single Operate	At Single Operate
	Weight	25 (Port 2.4) 19 (Port 1.3) kg (lbs)	25 (Port 2.4) 19 (Port 1.3)	25 (Port 2.4) 19 (Port 1.3)	25 (Port 2.4) 19 (Port 1.3)	25 (Port 2.4) 19 (Port 1.3)
Cylinder	Maker	NIPPON AIR BRAKE	NIPPON AIR BRAKE	NIPPON AIR BRAKE	NIPPON AIR BRAKE	NIPPON AIR BRAKE
	Bore x Rod x Stroke	φ125 x φ70 x 940 (φ4.9" x φ2.7" x 3' 1")	φ100 x φ70 x 975 (φ3.9" x φ2.7" x 3' 2")	φ105 x φ75 x 1097 (φ4.1" x φ2.9" x 3' 7")	φ125 x φ85 x 1290 (φ4.9" x φ3.3" x 4' 2")	φ140 x φ90 x 1334 (φ5.5" x φ3.5" x 4' 4")
	Weight	110 (240) kg (lbs)	90 (200)	100 (220)	170 (370)	210 (460)
	Bore x Rod x Stroke	φ110 x φ65 x 900 (φ4.3" x φ2.5" x 35.4")	φ115 x φ75 x 1085 (φ4.5" x φ2.9" x 3' 6")	φ120 x φ80 x 1185 (φ4.7" x φ3.1" x 3' 10")	φ145 x φ100 x 1453 (φ5.7" x φ3.9" x 4' 9")	φ150 x φ105 x 1630 (φ5.9" x φ4.1" x 5' 4")
	Weight	87 (190) kg (lbs)	120 (260)	150 (330)	250 (550)	320 (705)
	Bore x Rod x Stroke	φ95 x φ60 x 725 (φ3.7" x φ2.3" x 28.5")	φ95 x φ65 x 985 (φ3.7" x φ2.6" x 3' 2")	φ100 x φ65 x 915 (φ3.9" x φ2.5" x 36.0")	φ120 x φ85 x 1110 (φ4.7" x φ3.3" x 3' 7")	φ130 x φ84 x 1170 (φ5.1" x φ3.3" x 3' 10")
	Weight	58 (130) kg (lbs)	80 (175)	80 (175)	180 (395)	180 (395)
	Hydraulic tank capacity	75 (19.8) L (gal)	90 (23.7)	90 (23.7)	150 (39.6)	170 (45.0)

X60 SK100 SK120 SK120LC  
 X200 SK200LC SK220 SK220LC

PERFORMANCE DATA

Item Model	Fuel consumption e/h (gal/h)		Production amount m <sup>3</sup> /h (cuyd/h)		Cycle time at 90° Swing (sec)		Remarks
	H	S	H	S	H	S	
SK60	8.1 (2.1)				15.6	[ 19.02 ]	1. Soil : Soft Swinging 90° for loading on dump truck (Digging is start- ed from G.L.)  2. (These values are for reference.)
SK100	12.5 (3.3)	9.3 (2.4)	151 (197.8)	118 (154.5)	12.1	13.9	
SK120 SK120LC	13.0 (3.4)	10.1 (2.6)	180 (235.8)	157 (205.6)	13.1	13.5	
SK200 SK200LC	21.3 (5.6)	17.6 (4.6)	247 (323.5)	230 (301.3)	14.3	15.6	
SK220 SK220LC	21.3 (6.6)	20 (5.2)	337 (441.4)	311 (407.4)	15	16.1	

Values in ( ) show F.C.

NOISE LEVEL DATA

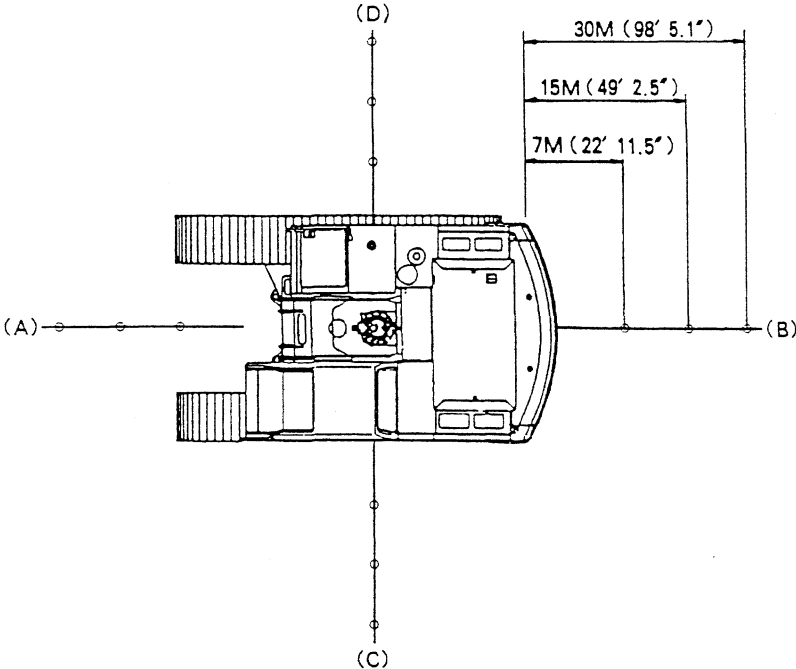

Test conditions (on standard specification machine)

Specification Model	7 M (27' 11.5")					15 M (49' 2.5")				
	Direction				Average noise value	Direction				Average noise value
	Forward (A)	Backward (B)	Left (C)	Right (D)		Forward (A)	Backward (B)	Left (C)	Right (D)	
SK60	6.7	6.9	6.8	6.9	6.9	6.3	6.3	6.0	6.5	6.3
SK100	6.5	7.0	6.9	7.2	7.0	6.2	6.4	6.4	6.5	6.4
SK120 SK120LC	6.5	6.8	6.8	6.8	6.8	6.2	6.4	6.1	6.6	6.3
SK200 SK200LC	6.5	7.1	7.0	7.1	7.0	6.1	6.6	6.6	6.7	6.5
SK220 SK220LC	6.6	7.4	7.2	7.2	7.2	6.2	6.9	6.4	6.7	6.6

Specification Model	30 M (98' 5.1")					At the point near the operator's ears in cab			
	Direction				Average noise value	Door OPEN		Door CLOSE	
	Forward (A)	Backward (B)	Left (C)	Right (D)		Right	Left	Right	Left
SK60	5.8	5.8	5.5	5.9	5.8	7.8	7.8	7.0	7.0
SK100	5.8	5.8	5.8	6.0	5.9	7.8	7.8	7.0	7.0
SK120 SK120LC	5.7	5.7	5.6	6.0	5.8	7.5	7.6	7.0	7.0
SK200 SK200LC	5.6	6.0	6.1	6.2	6.0	7.7	7.6	7.0	7.0
SK220 SK220LC	5.8	6.2	5.9	6.2	6.1	7.7	7.7	7.0	7.0

## WEIGHT OF COMPONENTS (DRY WEIGHT)

Unit : kg (lbs)

Item	Model	SK60
Complete Machine [std Export 400mm (24") shoe]		6,400(14,100)
1. Upper Frame Assy (incl. 1.1~1.8)		3,170(7,000)
1.1 · Counter-weight		750(1,650)
1.2 · Cab		250(550)
1.3 · Boom cylinder	※	120(260)
1.4 · Engine, radiator	※	270(600)
1.5 · Pump assy		53(115)
1.6 · Control valve		67(150)
1.7 · Fuel and Hydraulic tank	※	145(320)
1.8 · Swing motor & reduction unit		110(240)
2. Lower frame assy (incl. 2.1~2.9)		2,190(4,800)
2.1 · Swing ring		107(240)
2.2 · Travel motor & reduction unit		90 × 2(200 × 2)
2.3 · Idler assy		40 × 2(88 × 2)
2.4 · Lower roller assy		14 × 2(30 × 2)
2.5 · Upper roller assy		4.5 × 2(10 × 10)
2.6 · Track tension assy		26 × 2(57 × 2)
2.7 · Sprocket		28 × 2(62 × 2)
2.8 · Swivel joint		18(40)
2.9 · Track link with 400mm (16") shoe assy		760(1670)
· Track link with 500mm (20") shoe assy		880(1940)
· Track link with 600mm (24") shoe assy		1,040(2,290)
2.9.1 · Track link		150 × 2(330 × 2)
3. Attachment (incl. 3.1~3.3)		1,040(2,290)
3.1 · Bucket assy ( 0.25 m <sup>3</sup> (0.33cu yd) STD )		210(460)
3.2 · Arm assy ( 1.73m (5ft-8in) STD. ) (incl. following)		280(620)
3.2.1 · · Arm		150(330)
3.2.2 · · Bucket cylinder	※	64(140)
3.2.3 · · Idler link		18(39)
3.2.4 · · Bucket link		18(39)
3.2.5 · · Pin (2 pcs for mounting the arm cylinder and the bucket)		11(24)
3.3 · Boom assy ( includes the following : )		540(1,190)
3.3.1 · · Boom		440(970)
3.3.2 · · Arm cylinder	※	93(200)
3.3.3 · · Pin ( mounting the arm )		8(18)
4. Oil, grease, water, etc. (incl. 4.1~4.3)		220(480)
4.1 · · Hydraulic oil, engine oil		104(230)
4.2 · · Fuel		107(240)
4.3 · · Water		10(22)

※ mark dry weight.

Unit : kg (lbs)

Item	Model	SK100	SK120	SK120Lc
Complete Machine (std Export 500mm (20") shoe		10,500(23,100)	11,500(25,300)	11,700(25,800)
1. Upper Frame Assy (incl. 1.1~1.9)		4,680(10,300)	5,425(11,950)	←
1.1 · Counter-weight		1,300(2,870)	2,050(4,500)	←
1.2 · Cab		260(570)	←	←
1.3 · Boom cylinder		※ 90(200) × 2	※ 100(220) × 2	←
1.4 · Engine, radiator		※ 340(750)	※ 390(860)	←
1.5 · Pump assy		85(190)	←	←
1.6 · Control valve		105(230)	←	←
1.7 · Fuel tank		※ 75(160)	←	←
1.8 · Hydraulic tank		※ 105(230)	←	←
1.9 · Swing motor & reduction unit		※ 150(330)	※ 150(330)	←
2. Lower frame assy (incl. 2.1~2.9)		4,100(9,000)	4,150(9,100)	4,350(9,600)
2.1 · Swing ring		150(330)	←	←
2.2 · Travel motor & reduction unit		※ 170(370)	←	←
2.3 · Idler assy		65(140) × 2	←	←
2.4 · Lower roller assy		26(57) × 12	←	26(57) × 14
2.5 · Upper roller assy		8(18) × 2	←	←
2.6 · Track tension assy		56(120) × 2	←	←
2.7 · Sprocket		37(82) × 2	←	←
2.8 · Swivel joint		30(66)	←	←
2.9 · Track link with 500mm (20") shoe assy		1,360(3,000)	1,425(3,100)	1,510(3,330)
· Track link with 600mm (24") shoe assy		1,640(3,600)	1,720(3,800)	1,830(4,300)
· Track link with 700mm (27") shoe assy		1,770(3,900)	1,860(4,100)	1,990(4,390)
2.9.2 · Track link		270(600) × 2	285(630) × 2	290(640) × 2
3. Attachment (incl. 3.1~3.3)		1,720(3,792)	1,930(4,250)	←
3.1 · Bucket assy 0.4m <sup>3</sup> (0.52cuyd)		350(772)	390(860)	←
3.2 · Arm assy ( 2.27m (7ft-5in) STD. ) (incl. following) ( 2.5m (8ft-2in) STD. ) (incl. following)		490(1,080)	565(1,200)	←
3.2.1 · · Arm		310(688)	380(840)	←
3.2.2 · · Bucket cylinder		※ 86(190)	←	←
3.2.3 · · Idler link		32(71)	34(75)	←
3.2.4 · · Bucket link		34(75)	48(110)	←
3.2.5 · · Pin (2 pcs for mounting the arm cylinder and the bucket)		19(42)	←	←
3.3 · Boom assy (includes the following :)		875(1,930)	970(2,100)	←
3.3.1 · · Boom		730(1,610)	800(1,780)	←
3.3.2 · · Arm cylinder		※ 130(280)	※ 155(340)	←
3.3.3 · · Pin (mounting the arm)		15(33)	←	←
4. Oil, grease, water, etc. (incl. 4.1~4.3)		360(790)	←	←
4.1 · · Hydraulic oil, engine oil		133(290)	←	←
4.2 · · Fuel		205(450)	←	←
4.3 · · Water		22(49)	←	←

※ mark dry weight.

200 SK200LC

Item	Model	Unit : kg (lbs)	
		SK200	SK200LC
Complete Machine [ std Export 600mm (24") shoe ]		18,700(41,200)	19,500(43,000)
1. Upper Frame Assy (incl. 1.1~1.9)		8,660(19,100)	←
1.1 · Counter-weight		3,850(8,490)	←
1.2 · Cab		260(570)	←
1.3 · Boom cylinder		※ 205(452) × 2	←
1.4 · Engine, radiator		※ 550(1,210)	←
1.5 · Pump assy		260(570)	←
1.6 · Control valve		130(290)	←
1.7 · Fuel tank		※ 95(210)	←
1.8 · Hydraulic tank		※ 170(370)	←
1.9 · Swing motor & reduction unit		※ 235(520)	←
2. Lower frame assy (incl. 2.1~2.9)		6,780(14,900)	7,580(16,700)
2.1 · Swing ring		245(540)	←
2.2 · Travel motor & reduction unit		※ 305(670) × 2	←
2.3 · Idler assy		115(250) × 2	←
2.4 · Lower roller assy		34(75) × 14	34(75) × 16
2.5 · Upper roller assy		18(40) × 4	←
2.6 · Track tension assy		95(210) × 2	←
2.7 · Sprocket		115(250)	←
2.8 · Swivel joint		30(66)	←
2.9 · Track link with 600mm (24") shoe assy		1,275(2,810) × 2	1,420(3,130) × 2
· Track link with 800mm (32") shoe assy		1,570(3,460) × 2	1,700(3,750) × 2
2.9.1 · Track link		565(1,250) × 2	605(1,330) × 2
3. Attachment (incl. 3.1~3.3)		3,265(7,200)	←
3.1 · Bucket assy ( 0.7 m <sup>3</sup> (0.92cu yd) STD )		620(1,370)	←
3.2 · Arm assy ( 2.94m (9ft-8in) STD. ) (incl. following)		1,000(2,200)	←
3.2.1 · · Arm		620(1,370)	←
3.2.2 · · Bucket cylinder		145(320)	←
3.2.3 · · Idler link		60(130)	←
3.2.4 · · Bucket link		90(200)	←
3.2.5 · · Pin (2 pcs for mounting the arm cylinder and the bucket)		50(110)	←
3.3 · Boom assy (includes the following :)		1,635(3,600)	←
3.3.1 · · Boom		1,330(2,930)	←
3.3.2 · · Arm cylinder		270(600)	←
3.3.3 · · Pin (mounting the arm)		20(44)	←
4. Oil, grease, water, etc. (incl. 4.1~4.3)		525(1,160)	←
4.1 · · Hydraulic oil, engine oil		255(560)	←
4.2 · · Fuel		250(550)	←
4.3 · · Water		20(44)	←

※ mark dry weight.



Thank you so much for reading.  
Please click the “Buy Now!”  
button below to download the  
complete manual.



After you pay.

You can download the most  
perfect and complete manual in  
the world immediately.

Our support email:

[ebooklibonline@outlook.com](mailto:ebooklibonline@outlook.com)