

Product: MINI HYD EXCAVATOR

Model: 303ECR MINI HYD EXCAVATOR FR3

Configuration: 303ECR Mini Hydraulic Excavator FR300001-UP (MACHINE) POWERED BY C1.3 Engine

Disassembly and Assembly

C1.3 Engine for Caterpillar Built Machines

Media Number -UENR3292-03

Publication Date -01/05/2014

Date Updated -02/02/2017

i05318443

Governor - Install

SMCS - 1264-012

Removal Procedure

Table 1

Required Tools			
Tool	Part Number	Part Description	Qty
A	1P-1859	Retaining Ring Pliers	1
B	442-0744	Bushing Tool	1
C	-	Loctite 593 Silicone Sealer	

NOTICE

Keep all parts clean from contaminants.

Contaminants may cause rapid wear and shortened component life.

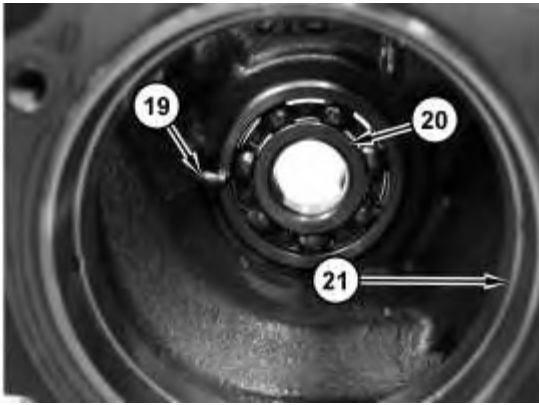

Illustration 1

g03370555

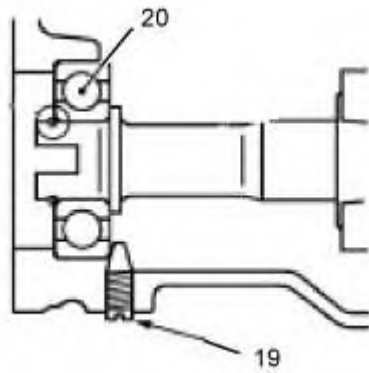

Illustration 2

g03381410

1. Install bearing (20). Apply Tooling (C) to set screw (19). Install set screw (19) until the tapered part contacts the bearing (20) as shown. Using Tooling (B), install bearing (21).

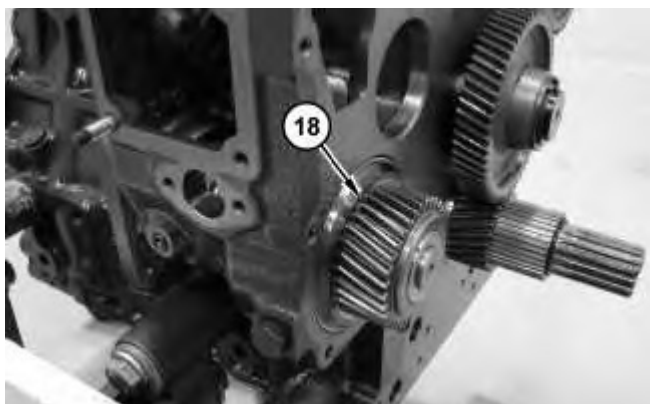

Illustration 3

g03370558

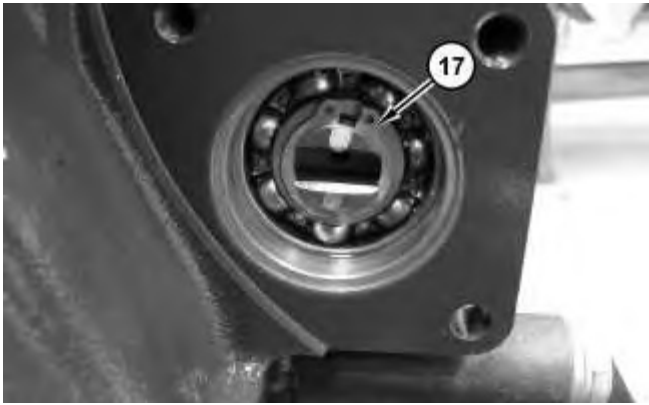

Illustration 4

g03370578



Illustration 5

g03370582

2. Install governor shaft and gear assembly (18). Install retaining ring (17) on shaft. Install plug (16).

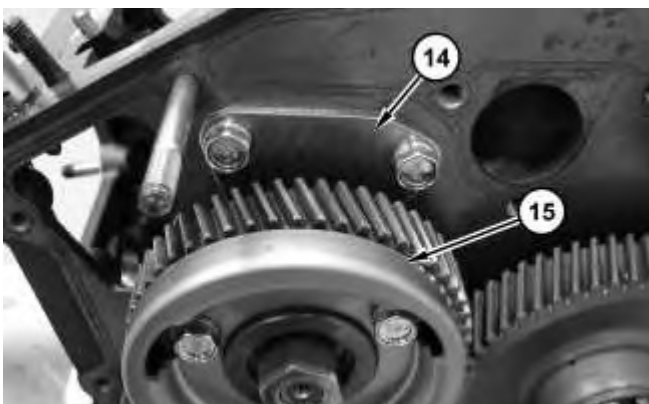

Illustration 6

g03370616

3. Install fuel camshaft gear assembly (15). Make sure to line up timing marks on gears upon installation. Install fuel camshaft stopper (14).



Illustration 7

g03370617

4. Install fork lever assembly (13) into the governor housing.

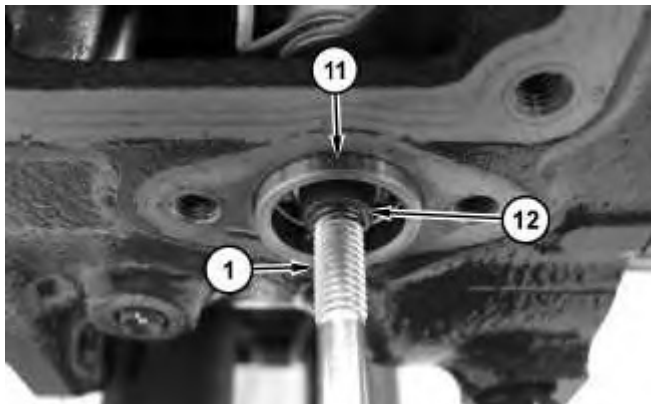

Illustration 8

g03370618

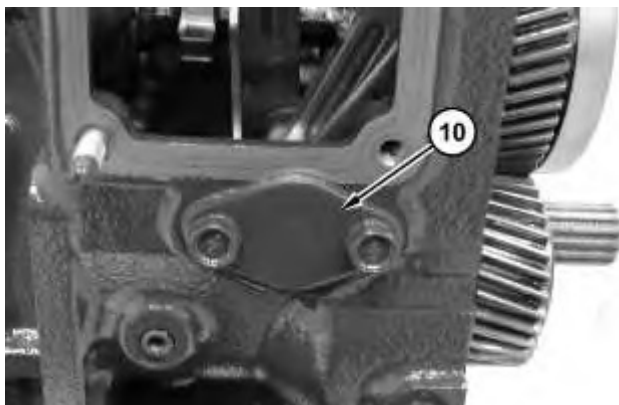

Illustration 9

g03370620

5. Use bolt (1) in order to install shaft (12) into the governor housing and fork lever assembly (13). Install bearing collar (11). Install plate (10).



Suggest:

If the above button click is invalid.

Please download this document

first, and then click the above link

to download the complete manual.

Thank you so much for reading