

Product: INDUSTRIAL ENGINE
Model: 3512B INDUSTRIAL ENGINE BRC
Configuration: 3512B Industrial Engine BRC00001-UP

Disassembly and Assembly 3500B Engines

Media Number -SEN6564-29

Publication Date -01/03/2015

Date Updated -14/09/2018

i02060168

Auxiliary Water Pump - Remove - Auxiliary Sea Water Pump

SMCS - 1052-016

Removal Procedure

NOTICE

Keep all parts clean from contaminants.

Contaminants may cause rapid wear and shortened component life.

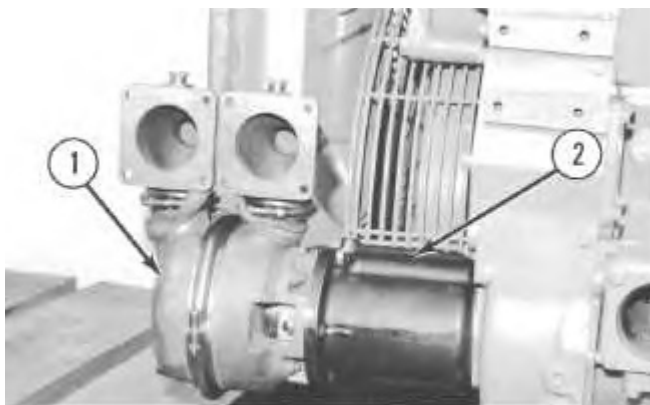

Illustration 1

g00602815

1. Remove the water lines from auxiliary water pump (1).

2. Attach a suitable lifting device to auxiliary water pump (1). The weight of the auxiliary water pump is approximately 59 kg (130 lb).
3. Remove the nuts and bolts that fasten auxiliary water pump (1) to housing (2). Remove auxiliary water pump (1).

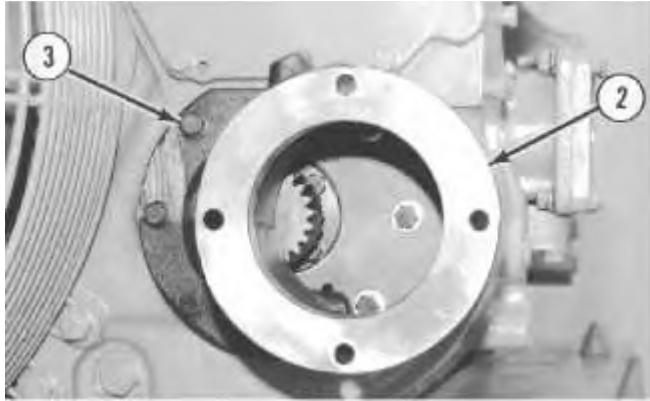

Illustration 2

g00602816

4. Remove bolts and washers (3) in order to remove housing (2). If necessary, remove the bearing from the housing.

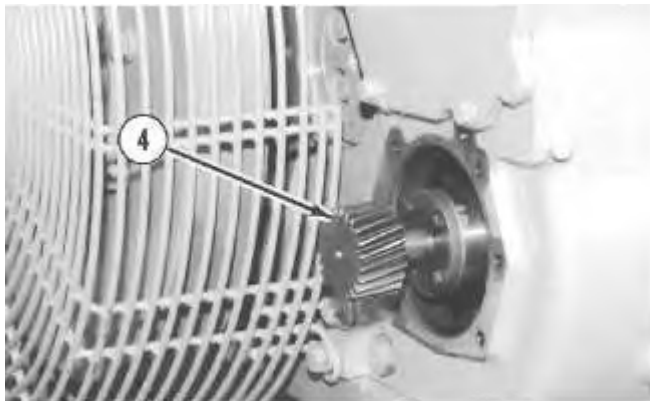

Illustration 3

g00602821

5. Remove the bolts and remove gear (4) from the accessory drive shaft.
-

Product: INDUSTRIAL ENGINE
Model: 3512B INDUSTRIAL ENGINE BRC
Configuration: 3512B Industrial Engine BRC00001-UP

Disassembly and Assembly 3500B Engines

Media Number -SEN6564-29

Publication Date -01/03/2015

Date Updated -14/09/2018

i02060956

Auxiliary Water Pump - Disassemble - Auxiliary Sea Water Pump

SMCS - 1052-016

Disassembly Procedure

Table 1

Required Tools			
Tool	Part Number	Part Description	Qty
A	1P-2320	Combination Puller	1
	8B-7560	Step Plate	1
B	8S-2264	Puller Group	1
	-	5/16 inch Bolt 18 NC 76.2 mm (3 inch) length	2
	4B-5270	Washer (5/16 inch)	2
C	136-1452	Retaining Ring Pliers As	1
D	152-7159	Socket As (Water Pump Shaft)	1
E	1U-7600	Slide Hammer Puller	1
F	1P-0074	Slide Hammer Puller	1

Start By:

- a. Remove the auxiliary water pump. Refer to Disassembly and Assembly, "Auxiliary Water Pump - Remove".
-

NOTICE

Keep all parts clean from contaminants.

Contaminants may cause rapid wear and shortened component life.

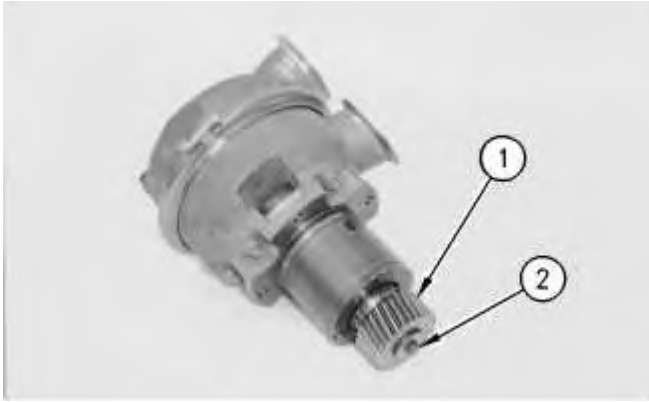

Illustration 1

g00603001



Illustration 2

g00603003

1. Loosen bolt (2) by approximately 3.0 mm (0.12 inch). Use Tooling (A) in order to pull gear (1) from the shaft. Remove Tooling (A), bolt (2), the washer, and gear (1) from the end of the shaft.
-



Illustration 3

g00690875

2. Remove clamp (3).

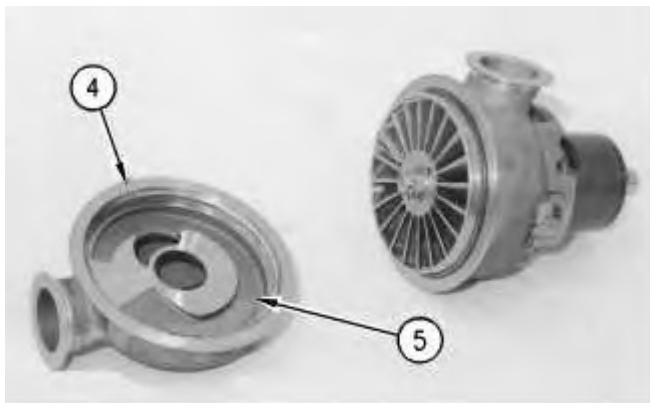

Illustration 4

g00603007

3. Remove body (4). Remove port plate (5) from the body.

Note: Be careful not to damage the threads of the nut and/or the shaft when you remove the cotter pin. Be sure that all of the cotter pin is completely removed before you remove the nut.



Illustration 5

g00690890

4. Remove the cotter pin. Remove nut (6) and the washer from the shaft.

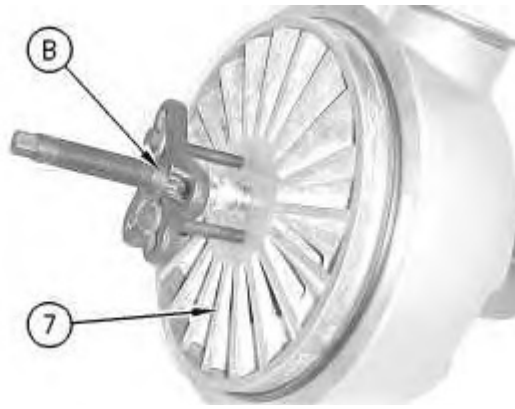

Illustration 6

g00603009

5. Use Tooling (B) in order to remove impeller (7) from the shaft.

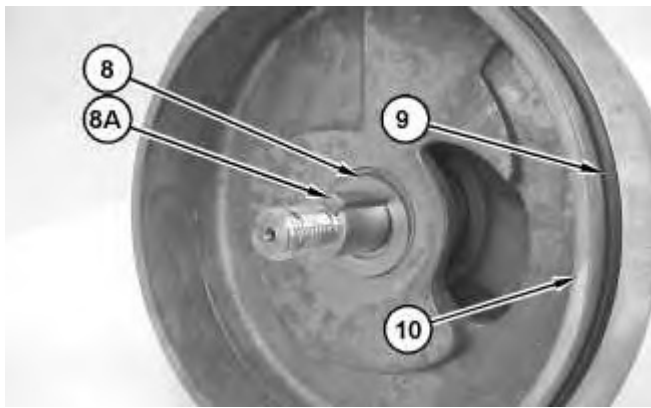

Illustration 7

g01058029

6. Remove key (8A). Remove shims (8), O-ring seal (9), and ring (10).

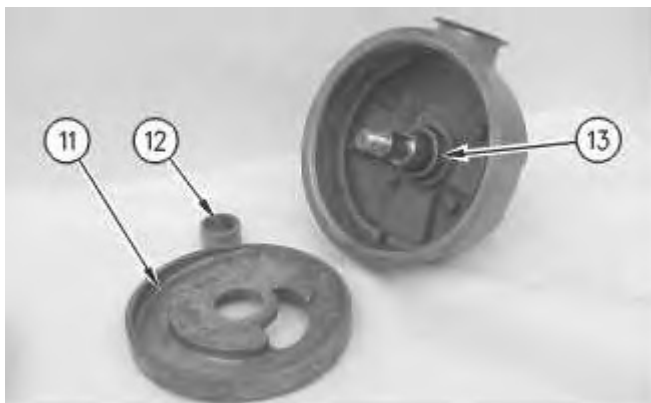

Illustration 8

g00603011

Note: It may be necessary to clean the inside of the body before the port plate can be removed.

7. Remove port plate (11) and spacer (12) from the drive housing.

Note: The ceramic seal has two sections. One section is stationary and one section rotates. Do not remove the ceramic seal unless it is necessary. The ceramic seal can be easily damaged.

8. Lubricate the shaft and the rotating section of ceramic seal (13) with a solution of water and five percent soap. Carefully pry the rotating section of the seal away from the drive housing. Remove the rotating section of the seal from the shaft.



Illustration 9

g00603013

9. Remove bolts (14) that hold drive housing (15) to bearing housing (16). Separate the drive housing from the bearing housing.

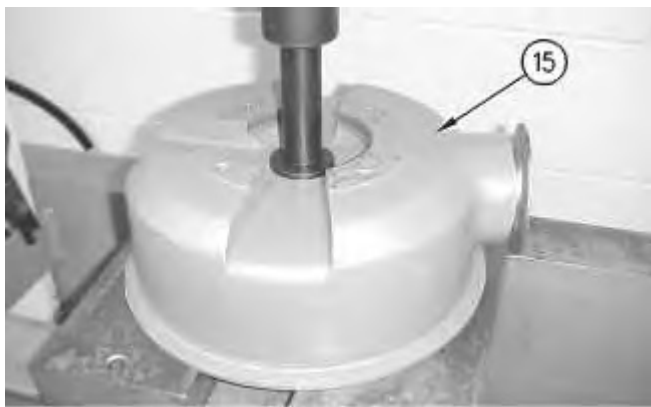

Illustration 10

g00690951

10. Use a suitable press in order to remove the stationary section of the ceramic seal from drive housing (15).
-

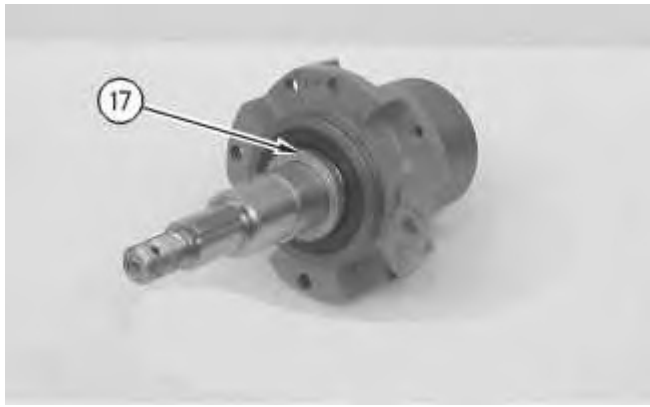

Illustration 11

g00690988

11. Use an allen wrench to loosen the screws that hold ring (17) to the shaft. Remove the ring.



Illustration 12

g01057040

12. Remove O-ring seal (19) and collar (18).

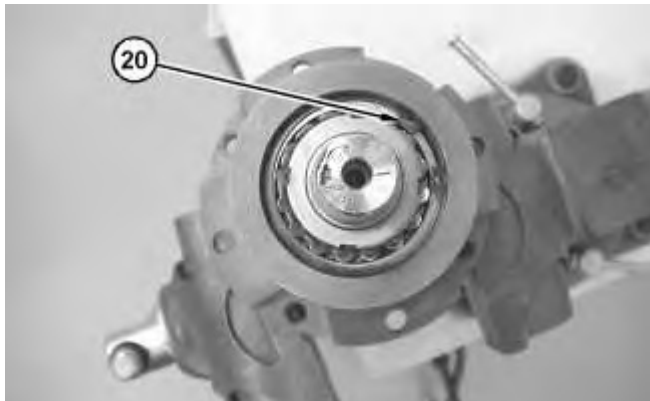

Illustration 13

g01057042

13. Place the bearing housing in a vise. Use Tooling (C) in order to remove retaining ring (20).

NOTICE

Do not allow the shaft to fall when the shaft is removed from the bearing housing.

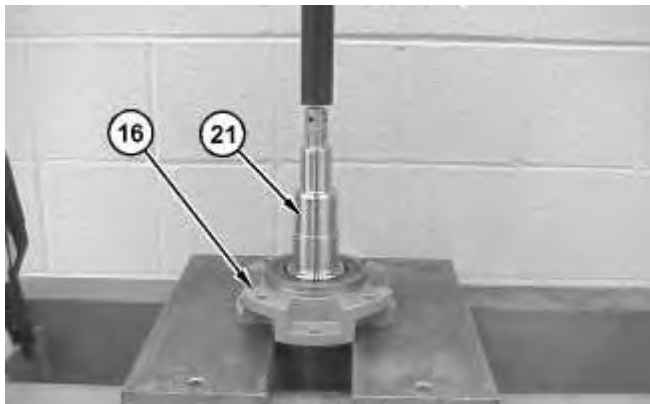

Illustration 14

g01057043

14. Place bearing housing (16) and shaft (21) in a press. Orient the impeller end of the shaft in the upward position. Press the shaft out of the bearing housing.

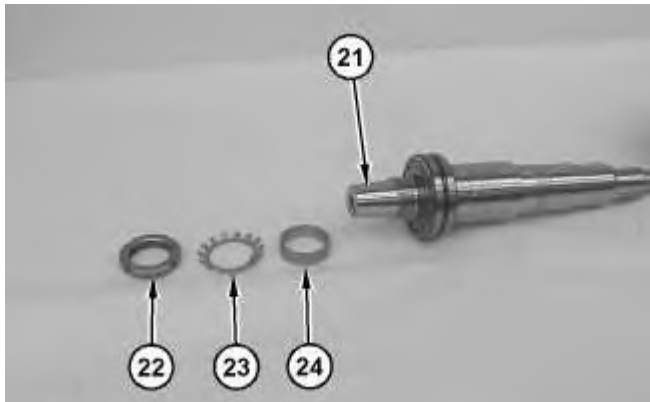

Illustration 15

g01057045

15. Place shaft (21) in a vise. Orient the driven end of the shaft in the upward position. Pry the tab of lock ring (23) out of the slot in nut (22).





16. Use Tooling (D) in order to remove nut (22) from shaft (21). Remove lock ring (23) and spacer (24).

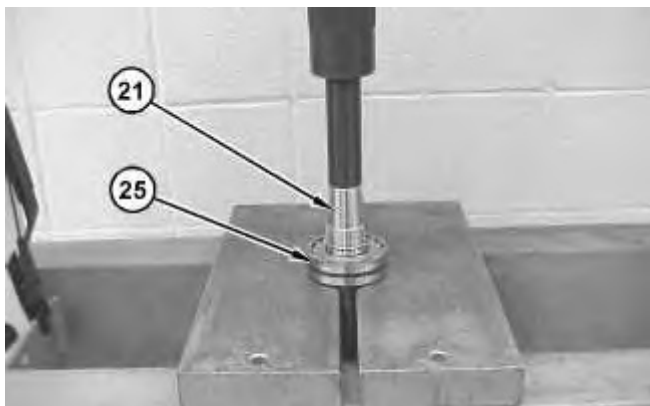

17. Place shaft (21) in a suitable press. Press the shaft out of bearing (25).

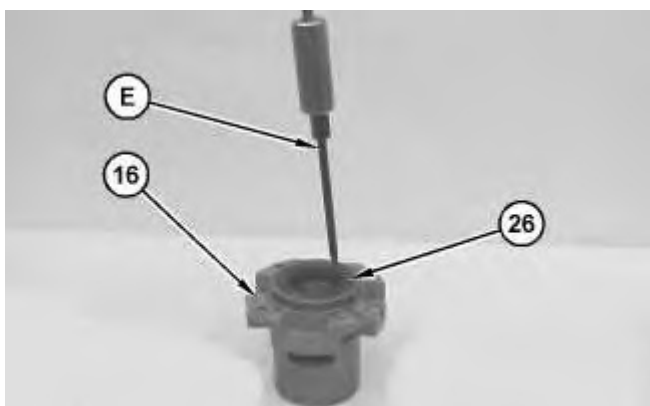

18. Use Tooling (E) in order to remove oil seal (26) from bearing housing (16).

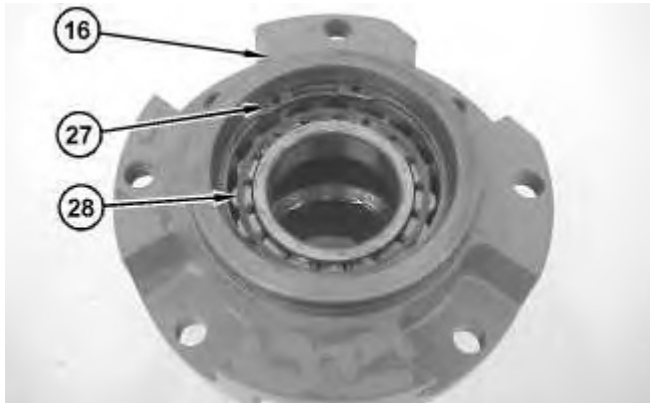

Illustration 20

g01057058

19. Use Tooling (C) in order to remove retaining ring (27) from bearing housing (16).

20. Remove bearing (28) from the bearing housing.



Illustration 21

g01057060



Illustration 22

g01057062

21. Use Tooling (F) in order to remove bearing race (29) from the bearing housing.

Product: INDUSTRIAL ENGINE
Model: 3512B INDUSTRIAL ENGINE BRC
Configuration: 3512B Industrial Engine BRC00001-UP

Disassembly and Assembly 3500B Engines

Media Number -SEN6564-29

Publication Date -01/03/2015

Date Updated -14/09/2018

i03237626

Auxiliary Water Pump - Disassemble - Auxiliary Pump (Type 2)

SMCS - 1052-016

Disassembly Procedure

Table 1

Required Tools			
Tool	Part Number	Part Description	Qty
A	242-9955	Puller (Two Jaw)	1
B	193-8094	Spline Socket	1
C	1P-0510	Driver Gp	1
D	5P-4758	Retaining Ring Pliers As	1
E	280-2059	Spanner Wrench Assembly	1
F	8T-0276	Bolt	2
G	8H-0663	Bearing Puller Gp	1

Start By:

- a. Remove the auxiliary water pump. Refer to Disassembly and Assembly, "Auxiliary Water Pump - Remove".

NOTICE

Keep all parts clean from contaminants.

Contaminants may cause rapid wear and shortened component life.

Disassemble the Check Valve

Note: If the hose assembly is leaking, the entire hose assembly must be replaced.

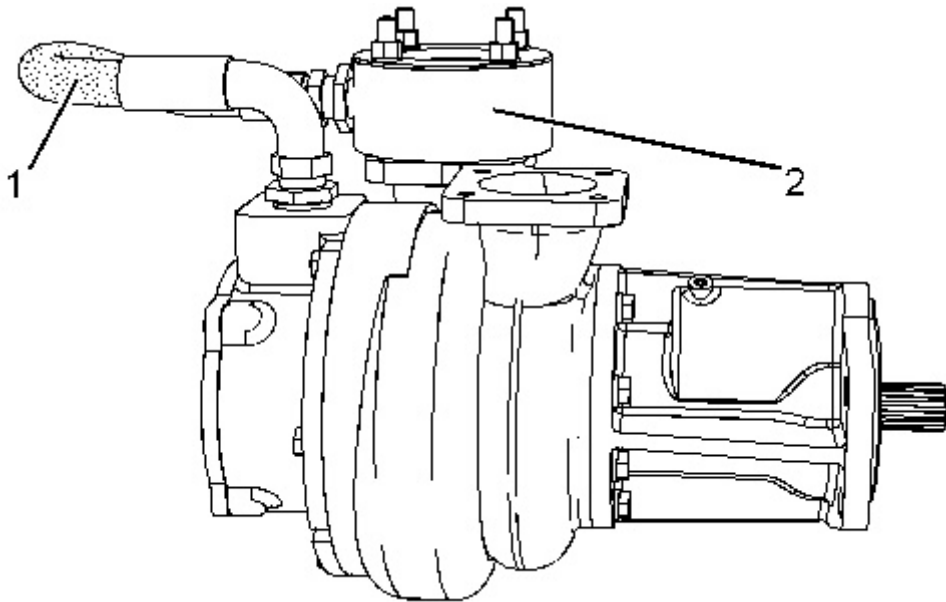

Illustration 1

g01644713

1. Remove hose assembly (1), check valve (2), and the gasket from the auxiliary water pump.
-

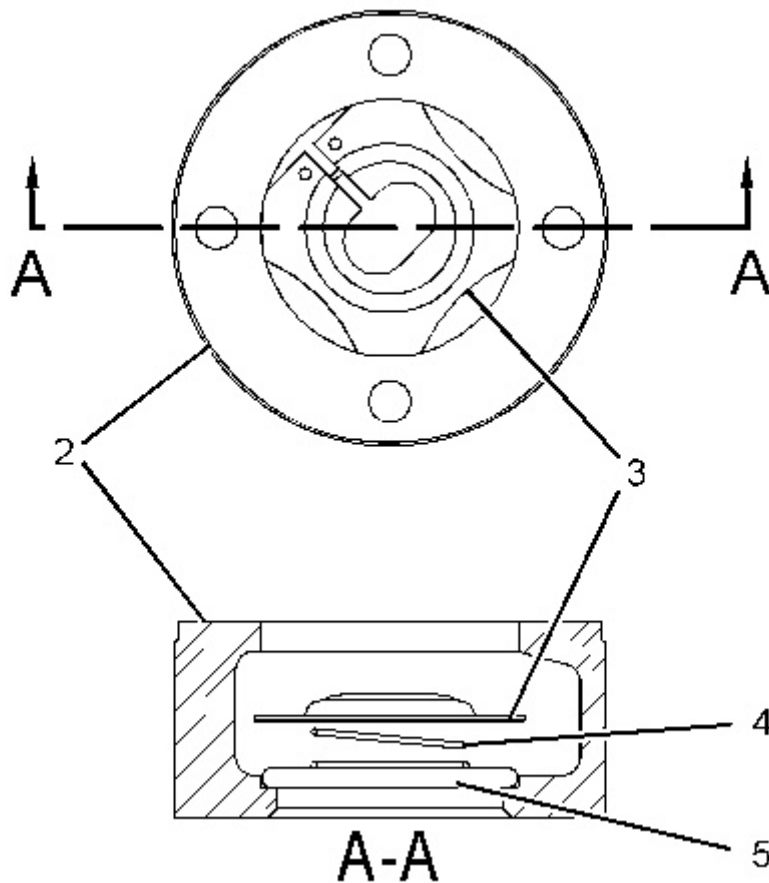

Illustration 2

g01644824

! WARNING

Personal injury can result from parts and/or covers under spring pressure.

Spring force will be released when covers are removed.

Be prepared to hold spring loaded covers as the bolts are loosened.

2. Use Tooling (D) in order to remove retainer (3) from the body of check valve (2).
3. Remove spring (4) and disc (5) from the body of check valve (2).

Disassemble the Pump

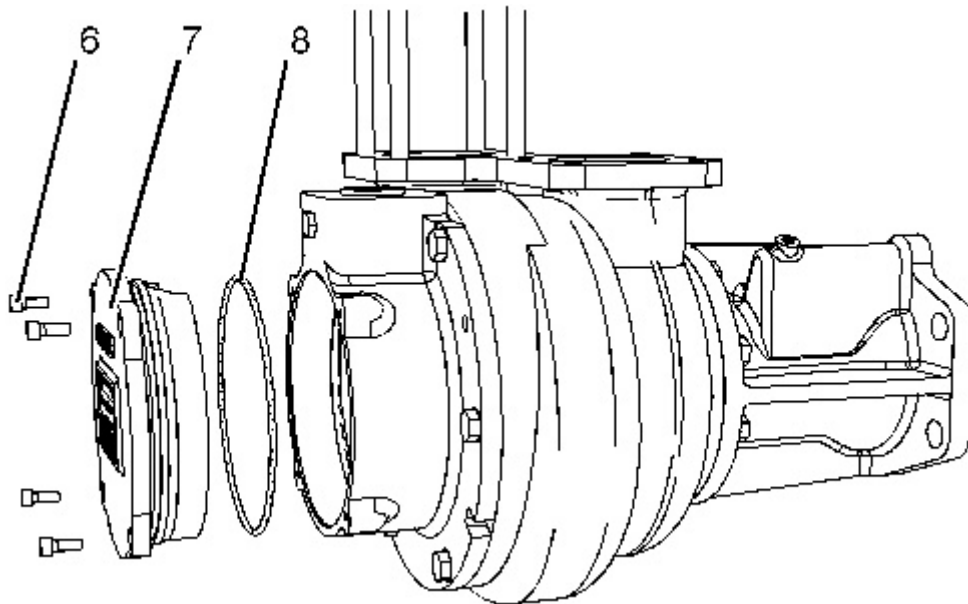

Illustration 3

g01645413

1. Remove bolts (6) and cover (7). Remove O-ring seal (8) from cover (7).

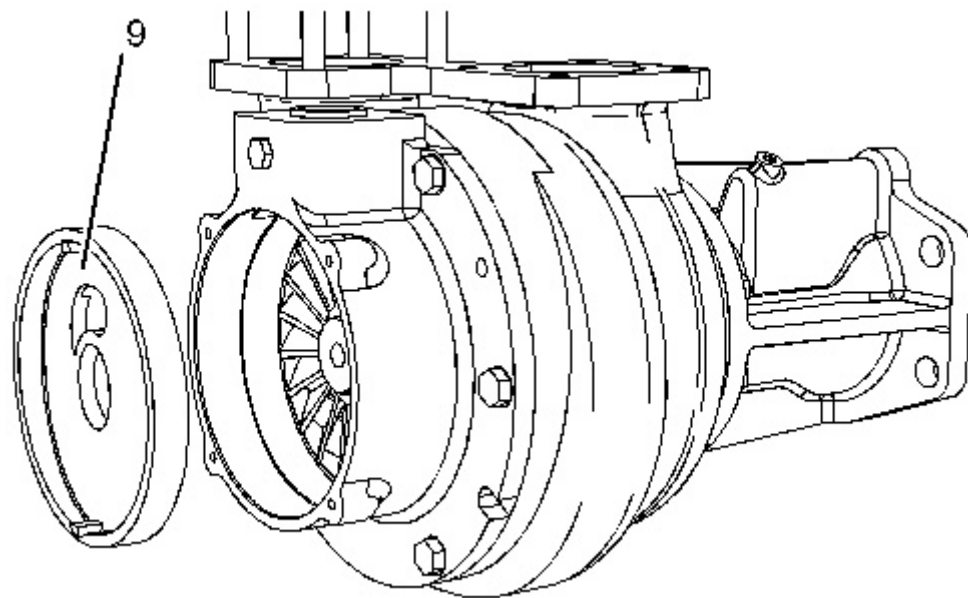

Illustration 4

g01645415

2. Remove port plate (9).
-

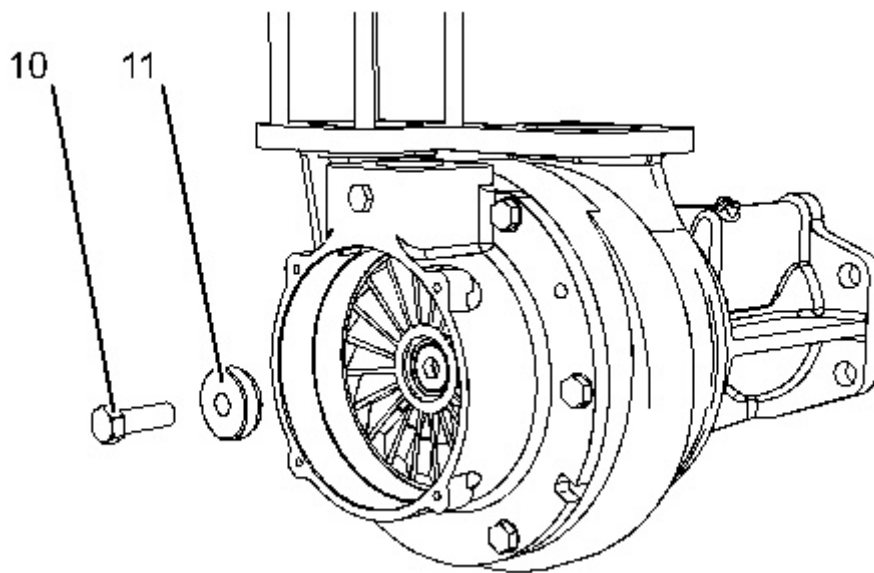

Illustration 5

g01645633

3. Use Tooling (B) to hold the end of the drive shaft. Remove bolt (10), thrust washer (11), and the O-ring seal.

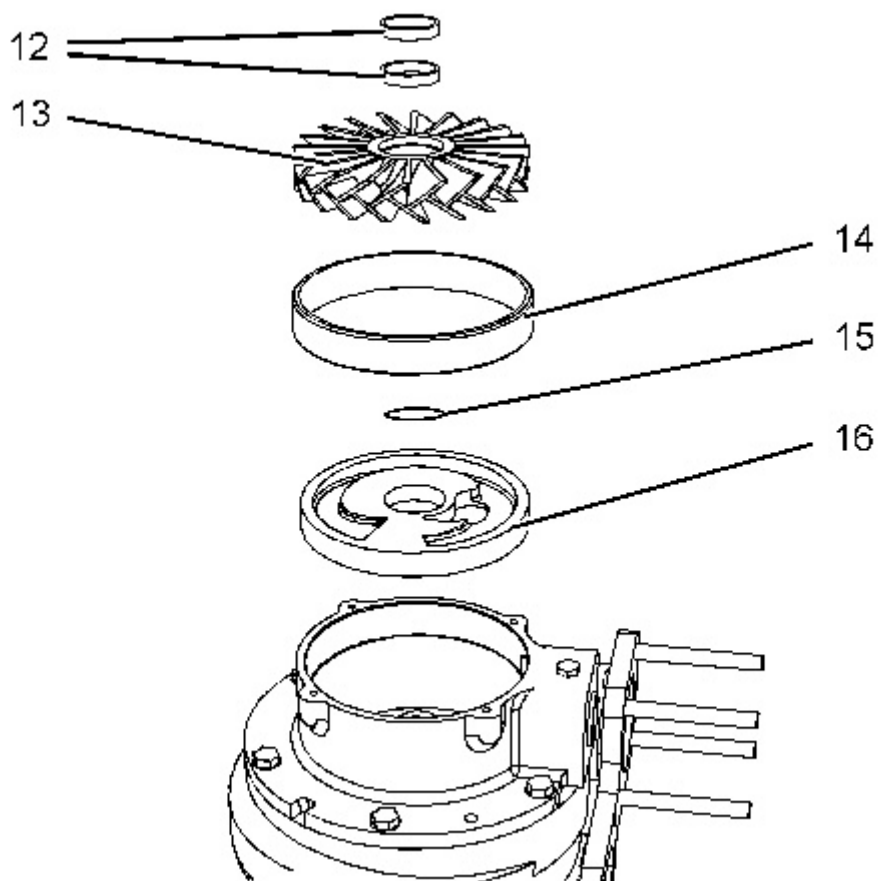

Illustration 6

g01645634

Note: Note the orientation of the locking rings during removal.

4. Position the auxiliary water pump in a vertical position on suitable cribbing. Ensure that the shaft assembly is supported. Use Tooling (C) and a suitable hammer to tap impeller (13). This will release the taper on locking rings (12). Remove lock rings (12), impeller (13), ring (14), O-ring seal (15), and port plate (16).

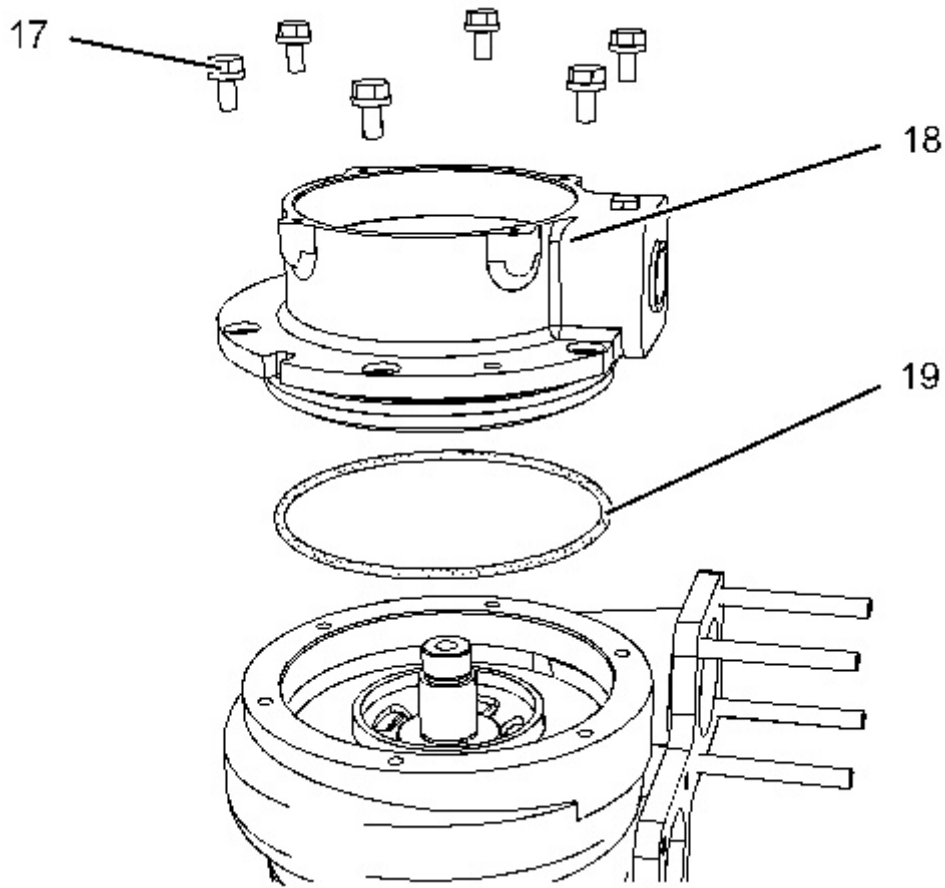

Illustration 7

g01645635

5. Remove bolts (17). Use bolts (17) as forcing bolts in order to remove body (18). Remove O-ring seal (19) from body (18).
-

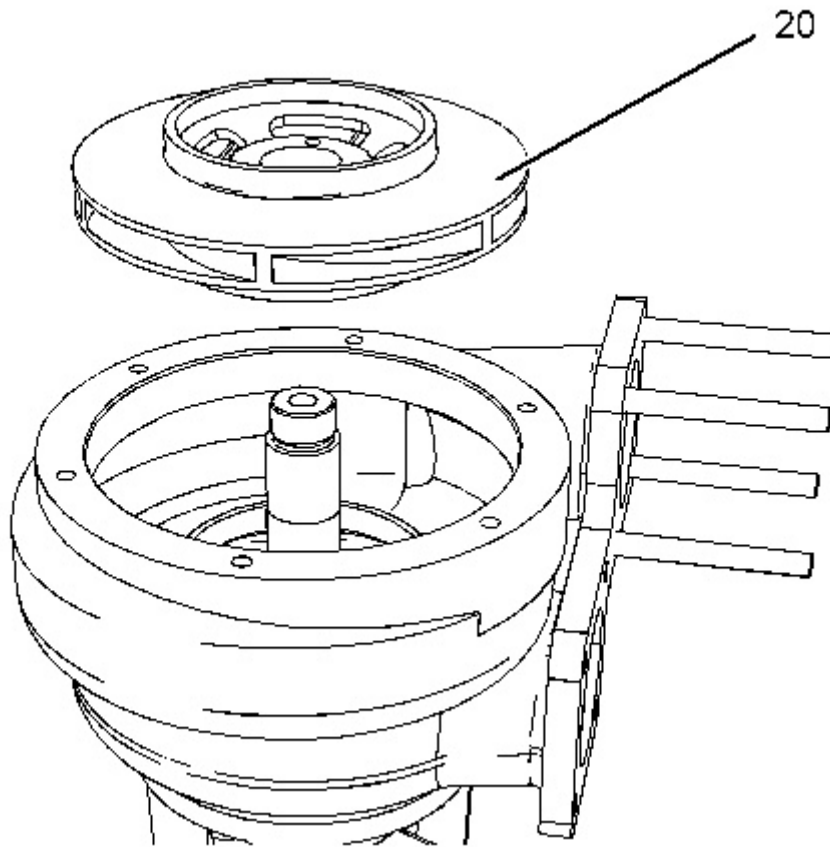

Illustration 8

g01646414

6. Use Tooling (A) and Tooling (C) in order to remove impeller (20).
-

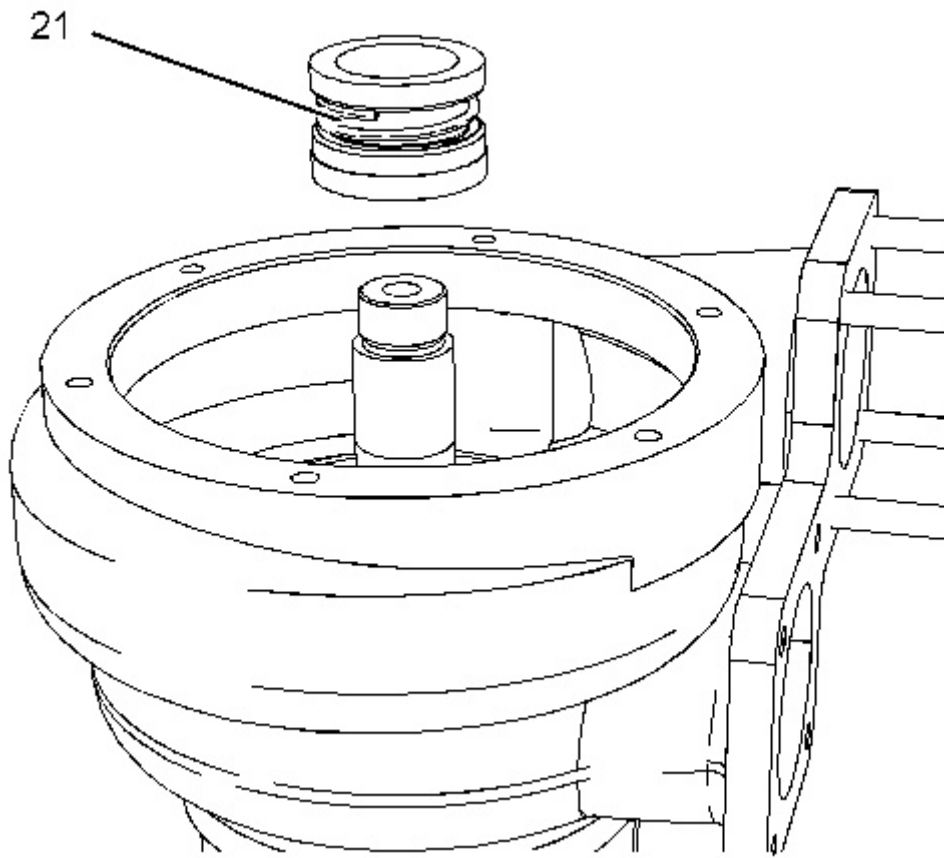

Illustration 9

g01646456

7. Remove the rotating segment of seal assembly (21) from the pump body.
-

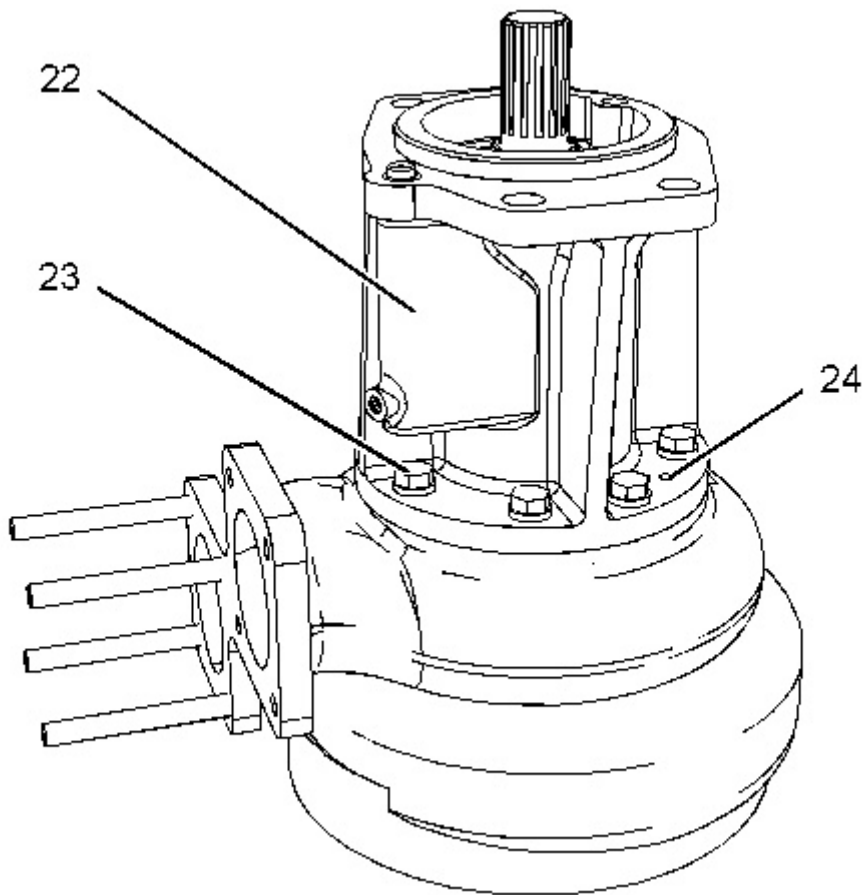

Illustration 10

g01646457

8. Place the auxiliary water pump in a vertical position on suitable cribbing, as shown. Remove bolts (23) from bearing housing (22). Use Tooling (F) in Holes (24) in order to separate bearing housing (22) from the pump body.
-

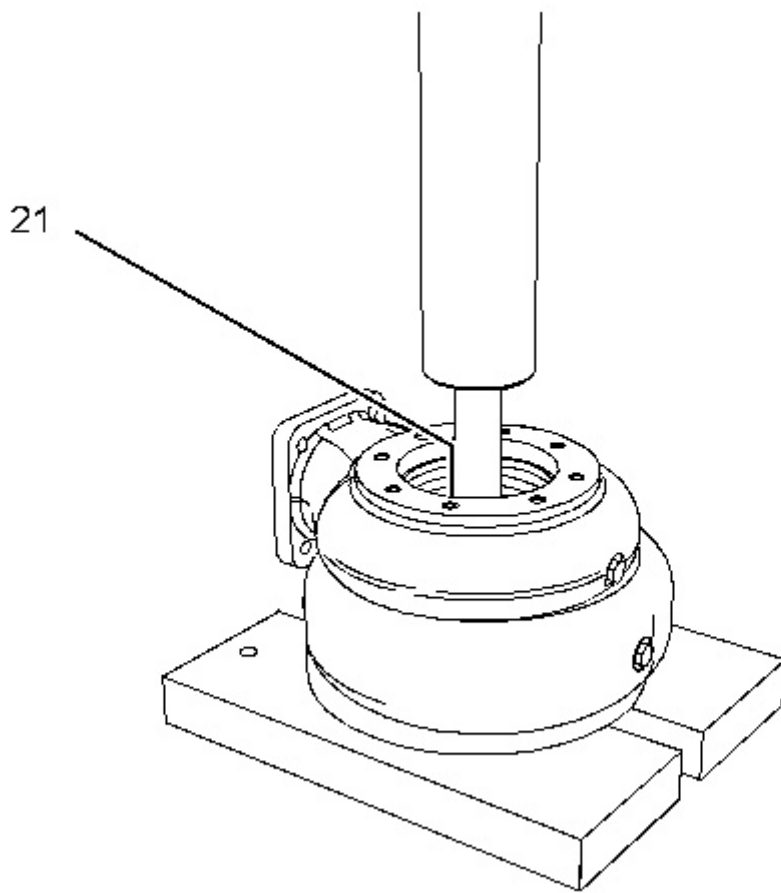

Illustration 11

g01721917

9. Use Tooling (C) and a suitable press to remove the stationary segment of seal assembly (21) from the pump body.
-

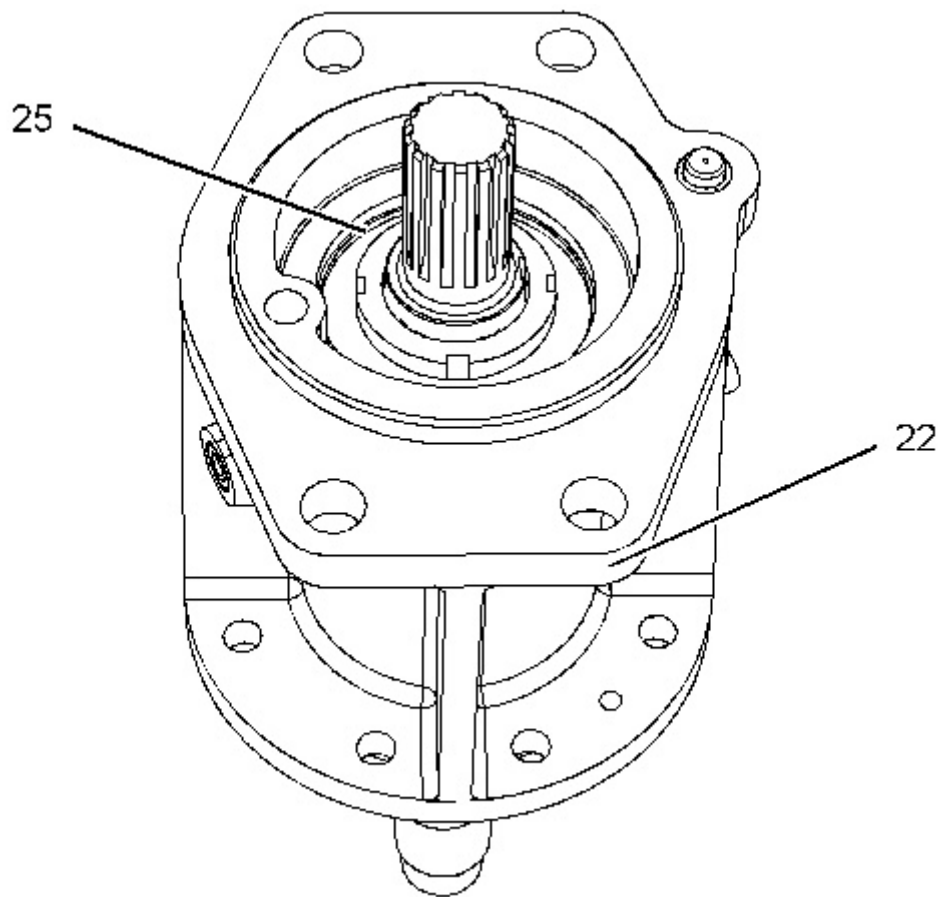

Illustration 12

g01646635

10. Use Tooling (D) to remove retaining ring (25) from bearing housing (22).
-

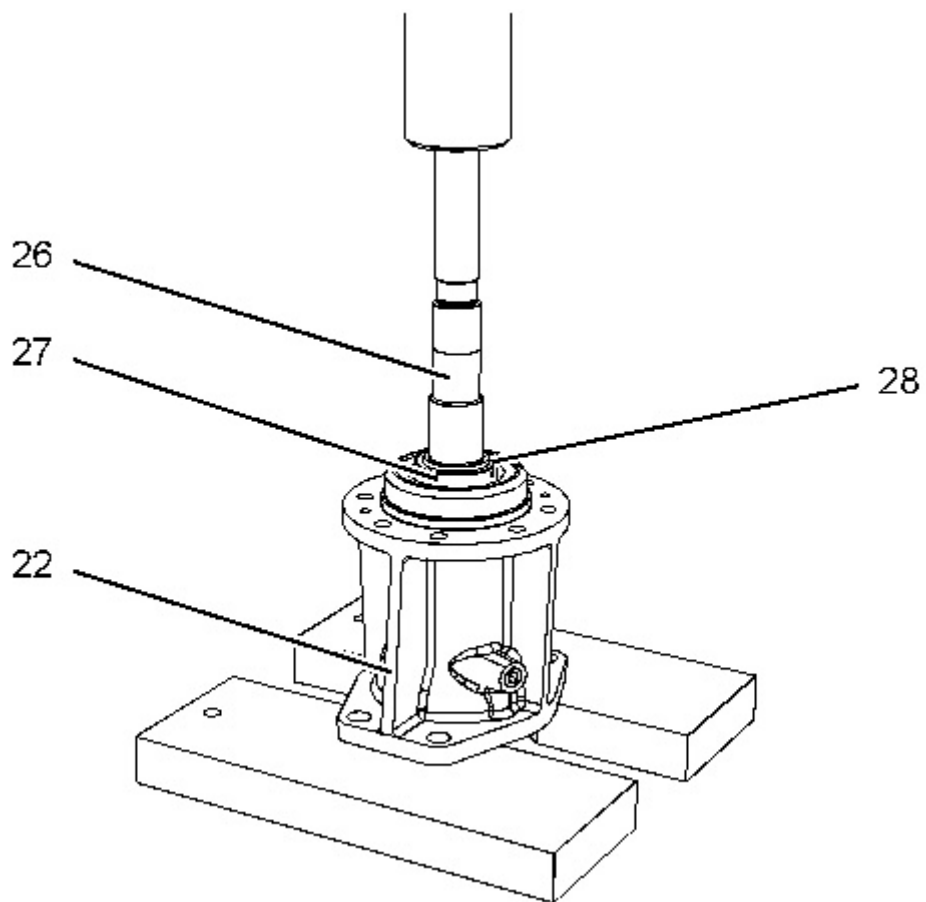

Illustration 13

g01646637

11. Remove setscrews (27) from seal collar (28). Use a suitable press to remove shaft assembly (26) from bearing housing (22). Remove shaft assembly (26), seal collar (28), and the O-ring seal.
-

Thank you so much for reading.
Please click the “Buy Now!”
button below to download the
complete manual.



After you pay.

You can download the most
perfect and complete manual in
the world immediately.

Our support email:

ebooklibonline@outlook.com