

Product: ENGINE  
Model: 3512E ENGINE SY6  
Configuration: 3512E Marine Engine SY600001-UP

## **Disassembly and Assembly 3512E and 3516E Marine Engines**

Media Number -M0075247-08

Publication Date -01/09/2018

Date Updated -11/09/2018

i06862848

# **Aftercooler - Remove and Install**

SMCS - 1063-010

## **Removal Procedure**

---

### **NOTICE**

**Care must be taken to ensure that fluids are contained during performance of inspection, maintenance, testing, adjusting, and repair of the product. Be prepared to collect the fluid with suitable containers before opening any compartment or disassembling any component containing fluids. Refer to Special Publication, NENG2500, “Dealer Service Tool Catalog” for tools and supplies suitable to collect and contain fluids on Cat® products. Dispose of all fluids according to local regulations and mandates.**

---

---

### **NOTICE**

**Keep all parts clean from contaminants. Contaminants may cause rapid wear and shortened component life.**

---

---

### **NOTICE**

**Clamp assemblies MUST only be used once. Discard all clamp assemblies after use.**

---

---

## NOTICE

**Bellows assemblies MUST only be used once. Discard all bellows assemblies after use.**

---

---

## NOTICE

**Inspect all seals and O-rings for wear and damage and replace if necessary.**

---

---

1. Drain the coolant from the cooling system into a suitable container for storage or for disposal. Refer to Disassembly and Assembly, "Cooling System Coolant - Change".
- 

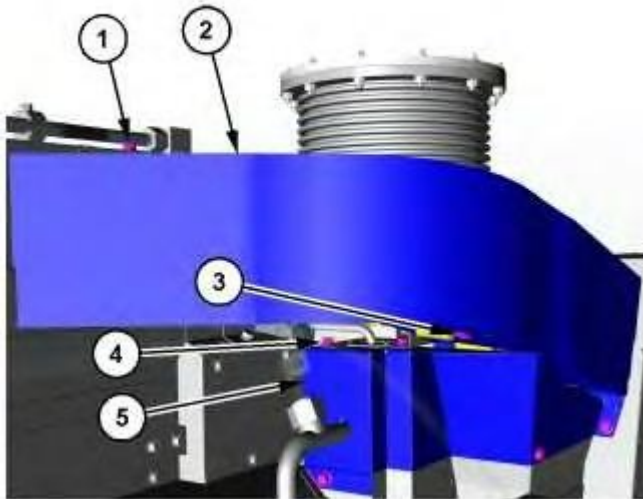
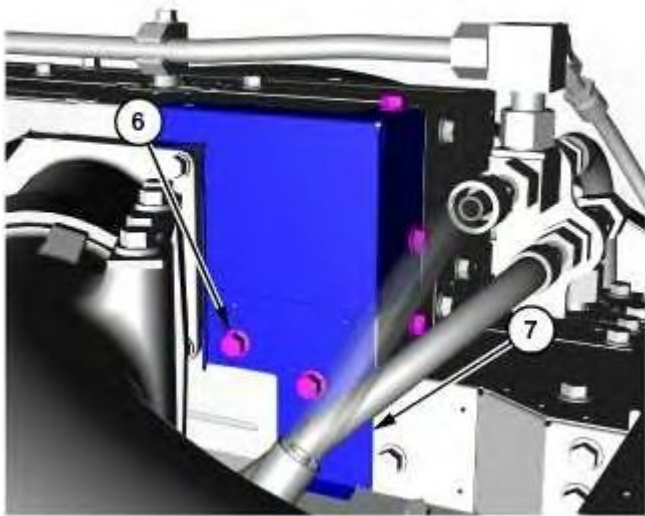

Illustration 1

g06145707

2. Remove five bolts (4) and remove shield (5).
  3. Disconnect twelve rings (3) and remove one bolt (1) to remove shield (2).
-



---

Illustration 2

g06145734

4. Remove five bolts (6) and remove shield (7).

---

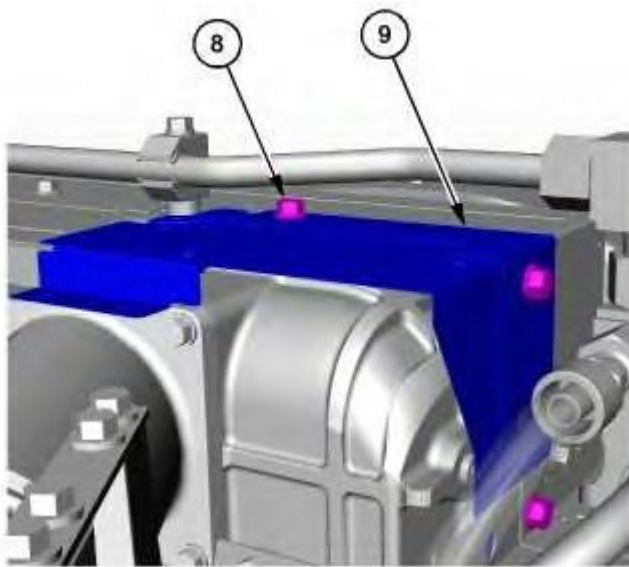

---

Illustration 3

g06145741

5. Remove three bolts (8) and remove shield (9).

---

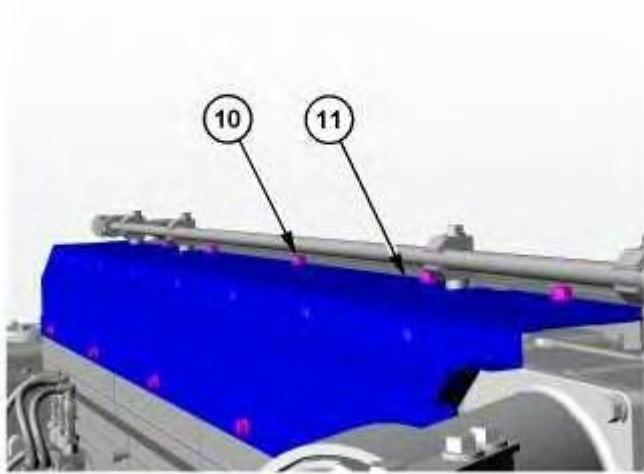

Illustration 4

g06145752

6. Remove thirteen bolts (10) and remove shield (11). Two bolts (10) are not shown.

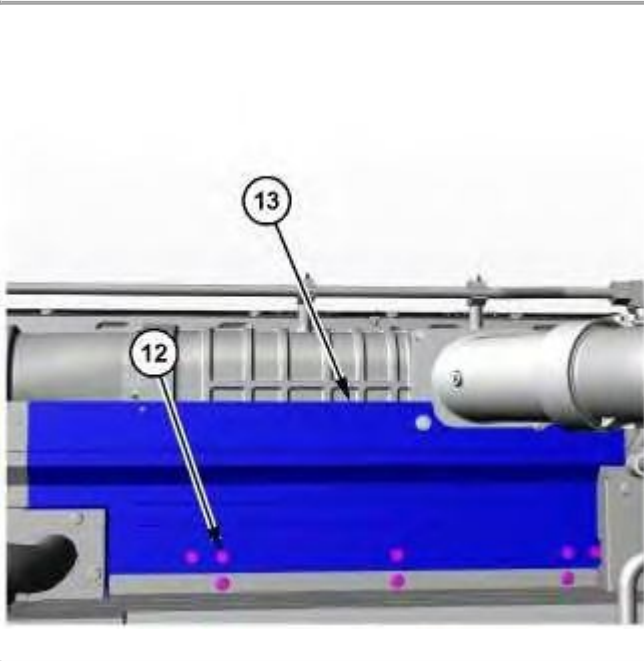

Illustration 5

g06145774

7. Remove seven bolts (12) and remove shield (13).

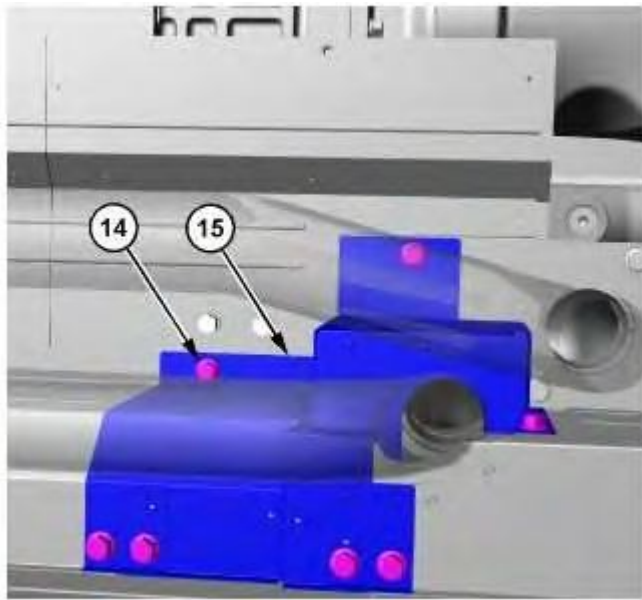

Illustration 6

g06145783

8. Remove seven bolts (14) and remove shield (15).

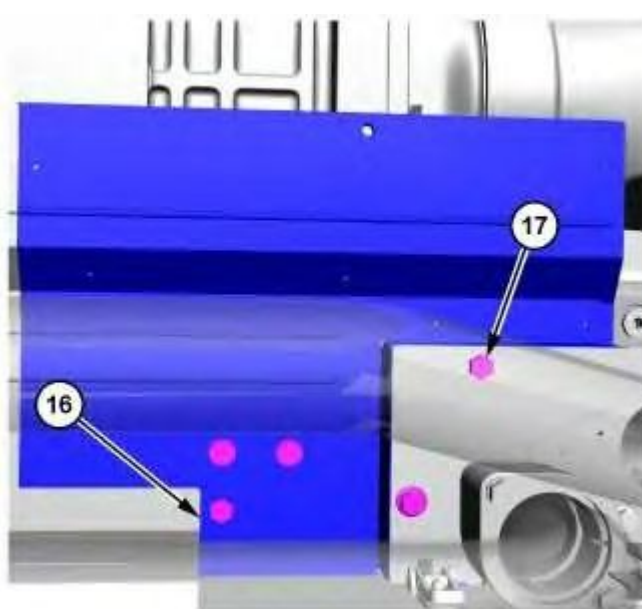

Illustration 7

g06145807

9. Remove five bolts (17) and remove shield (16).

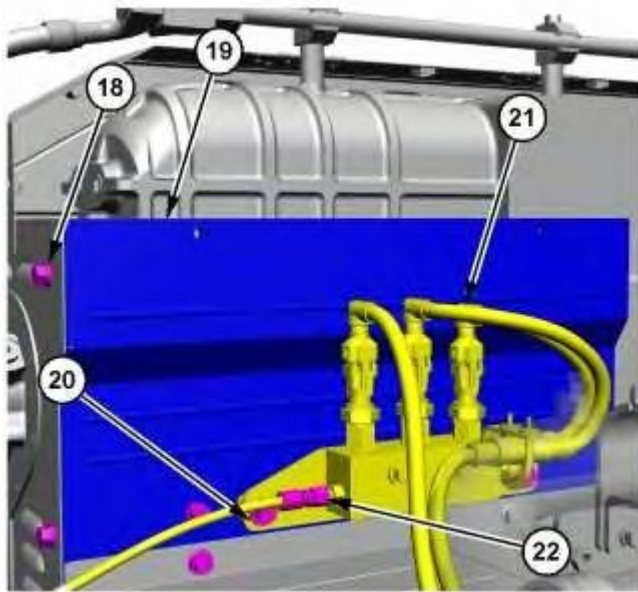

Illustration 8

g06145851

10. Disconnect nut (22).
11. Remove two bolts (20) and set harness (21) , off to the side.
12. Remove four bolts (18) and remove shield (19).

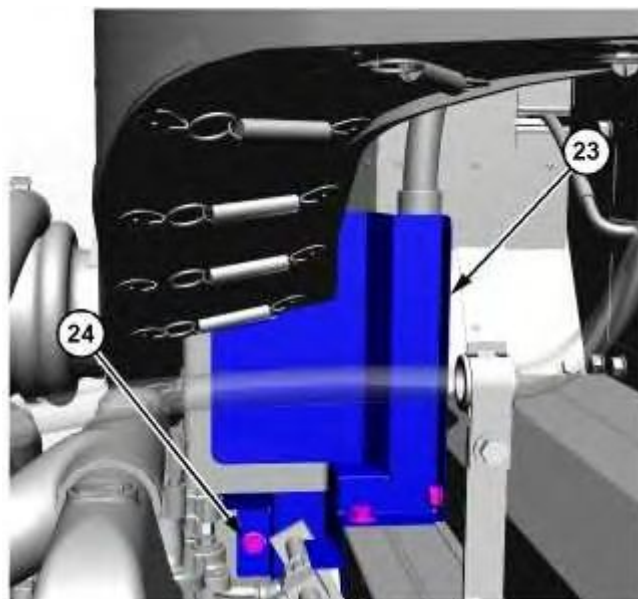
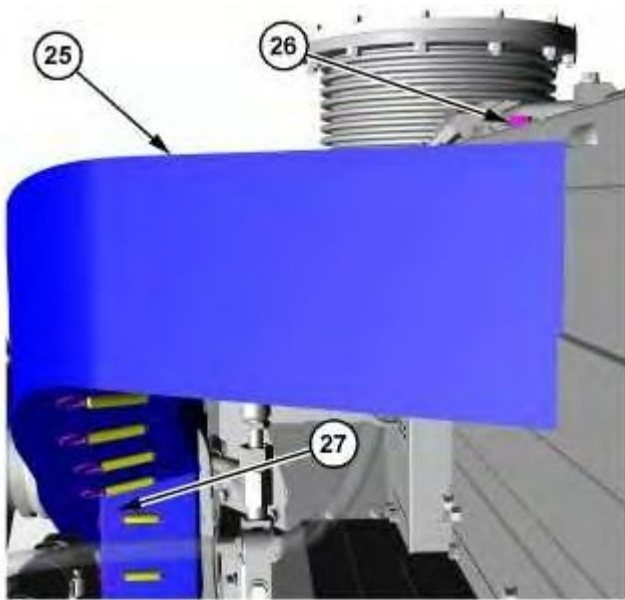

Illustration 9

g06145906

13. Remove three bolts (24) and remove shield (23).



---

Illustration 10

g06145953

14. Remove one bolt (26).
  15. Disconnect fourteen rings (27) and remove shield (25).
- 

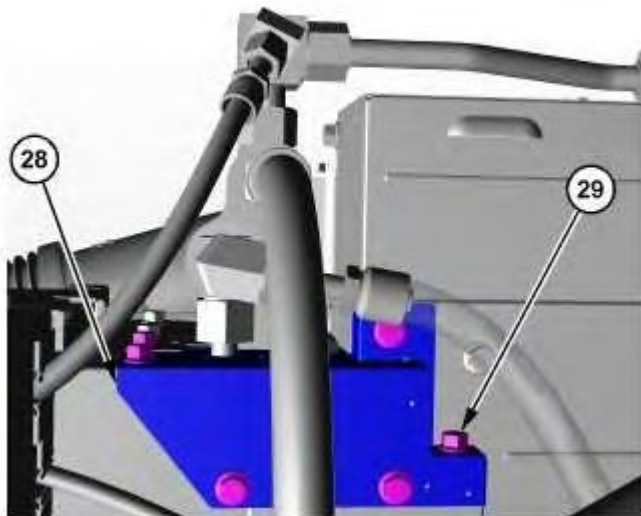

---

Illustration 11

g06145957

16. Remove six bolts (29) and remove shield (28).
-

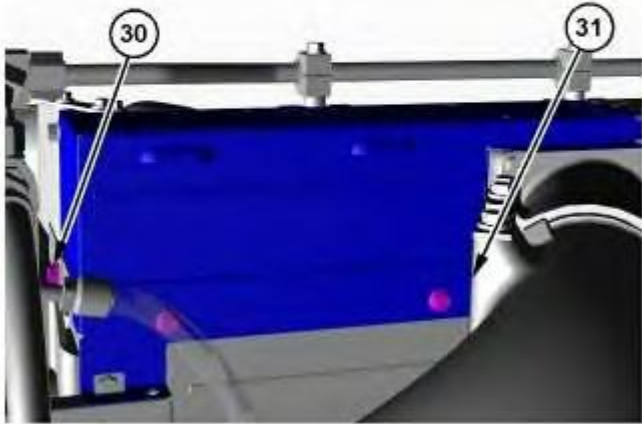

Illustration 12

g06146079

17. Remove three bolts (30) and remove shield (31).

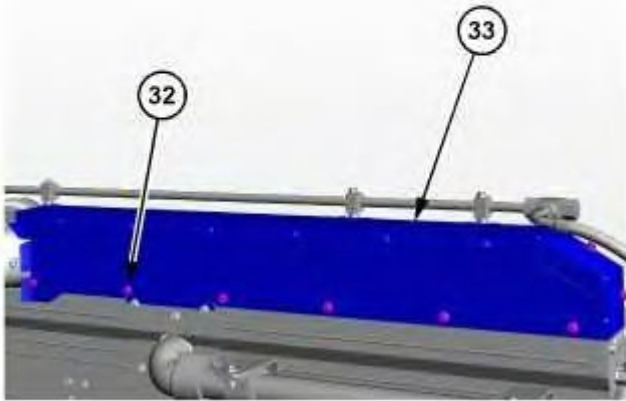

Illustration 13

g06146080

18. Remove eight bolts (32) and remove shield (33).



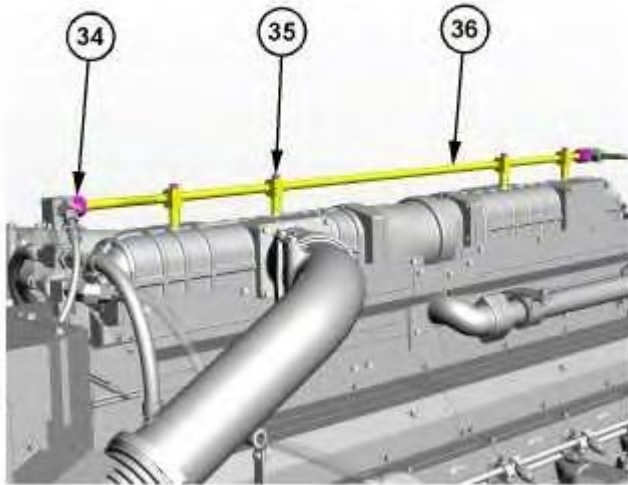

Illustration 14

g06146092

19. Disconnect two swivel nuts (34) remove four bolts (35) and remove tube assembly (36).

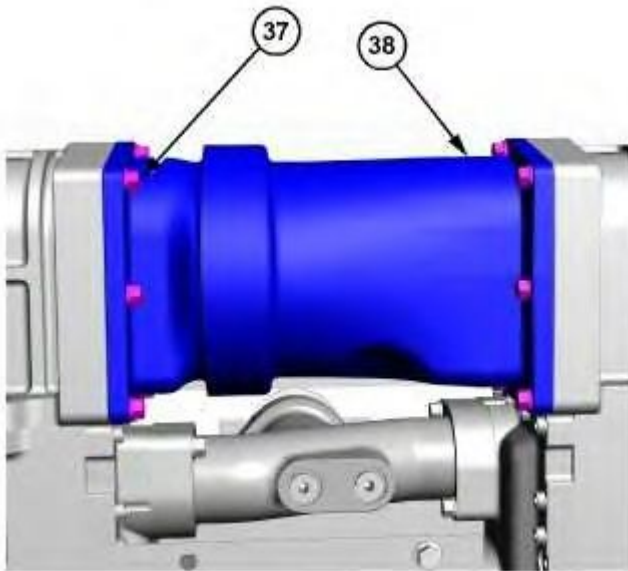

Illustration 15

g06146133

20. Remove 16 bolts (37) and remove two adapters (38).

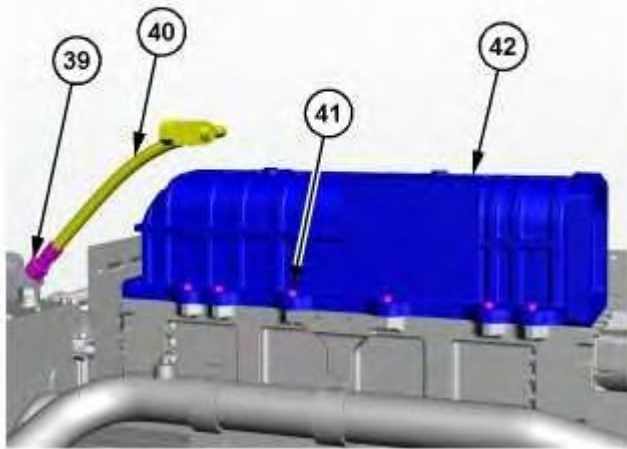

Illustration 16

g06146146

21. Attach a suitable lifting device to air inlet cover (42). The air inlet cover weighs approximately 32 kg (70 lb).
22. Disconnect nut (39) and set hose (40) out of the way.
23. Remove twelve bolts (41) and remove the air inlet cover (42).

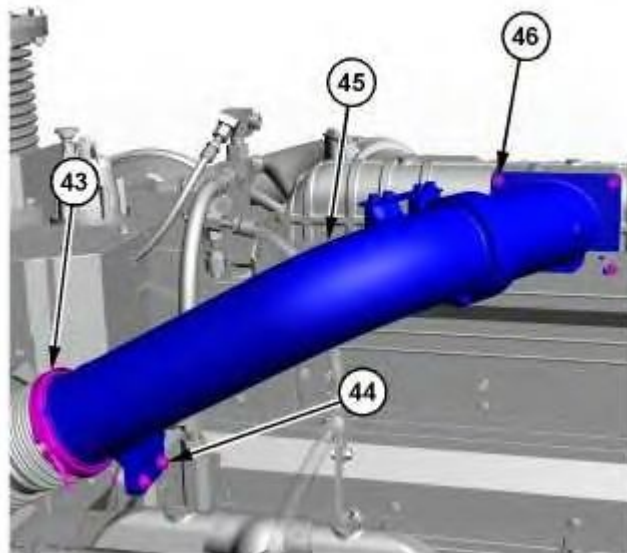

Illustration 17

g06146167

24. Disconnect V-band clamp (43) and remove two bolts (44).
25. Remove four bolts (46) and remove air pipe (45). One bolt (46) is not shown.

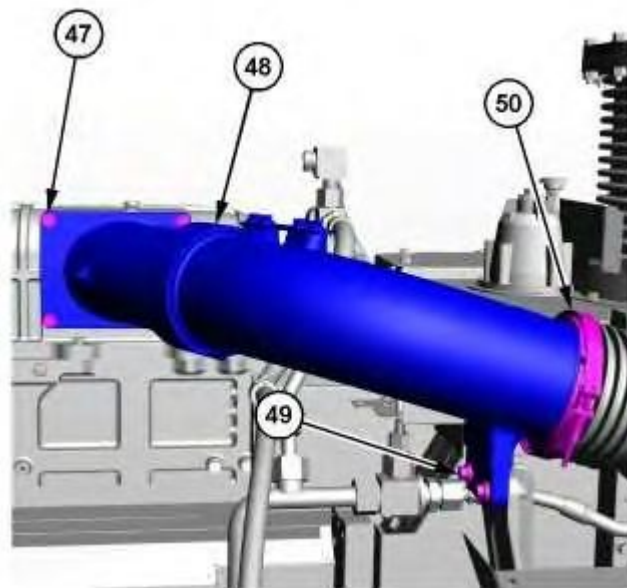

Illustration 18

g06146185

26. Remove four bolts (47). One bolt (47) is not shown.
27. Remove two bolts (49) and V-band clamp (50) to remove air pipe (48).

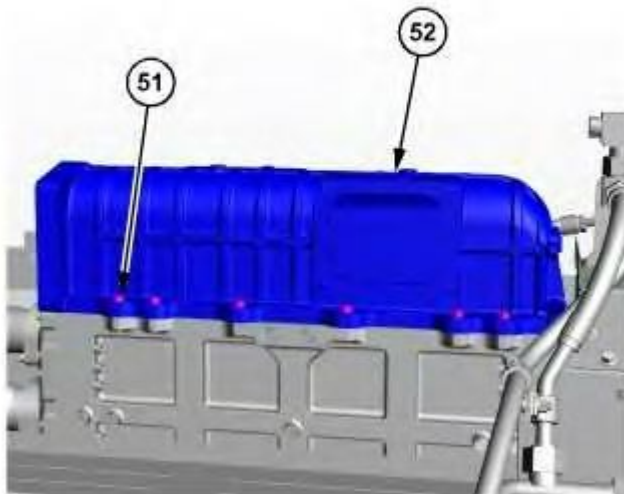

Illustration 19

g06146212

28. Attach a suitable lifting device to air inlet cover (52). The air inlet cover weighs approximately 29 kg (64 lb).
29. Remove twelve bolts (51) and remove air inlet cover (52).

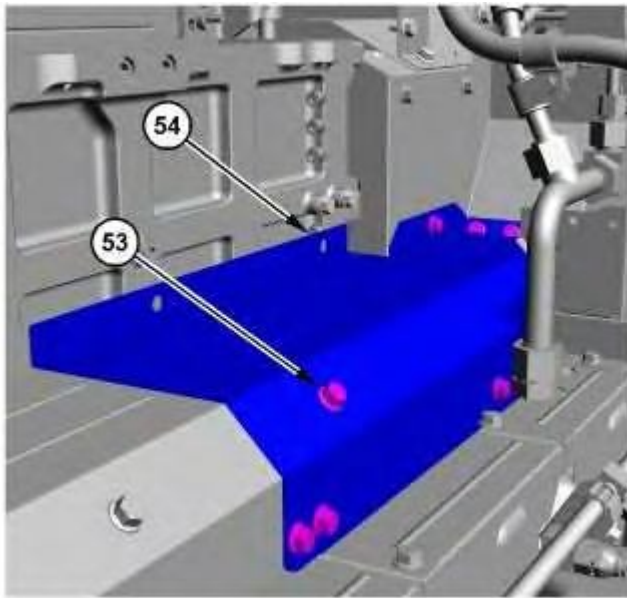

Illustration 20

g06146257

30. Remove seven bolts (53) and remove shield (54).

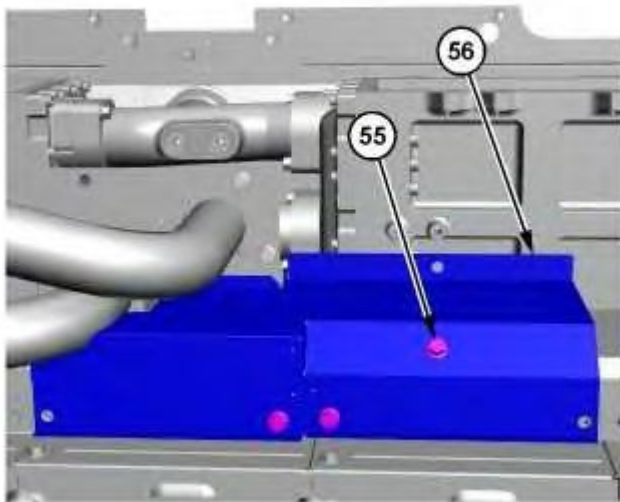

Illustration 21

g06146276

31. Remove three bolts (55) and remove shield (56).

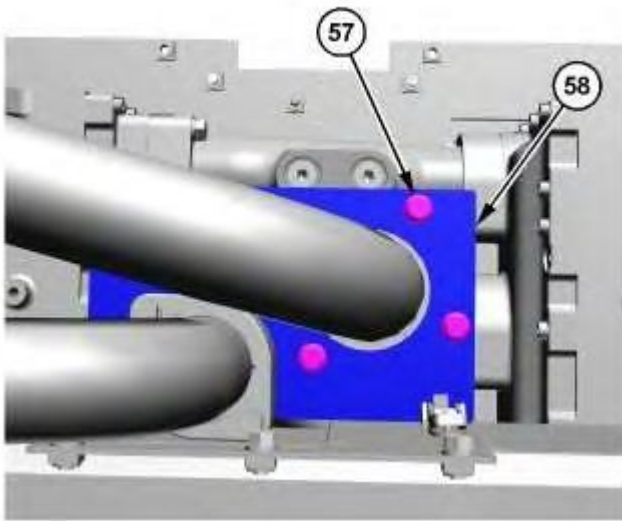

Illustration 22

g06146294

32. Remove three bolts (57) and remove two shields (58).

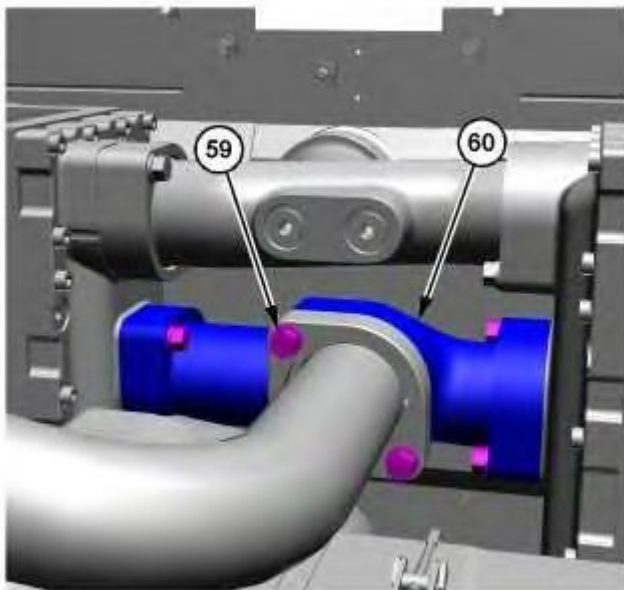
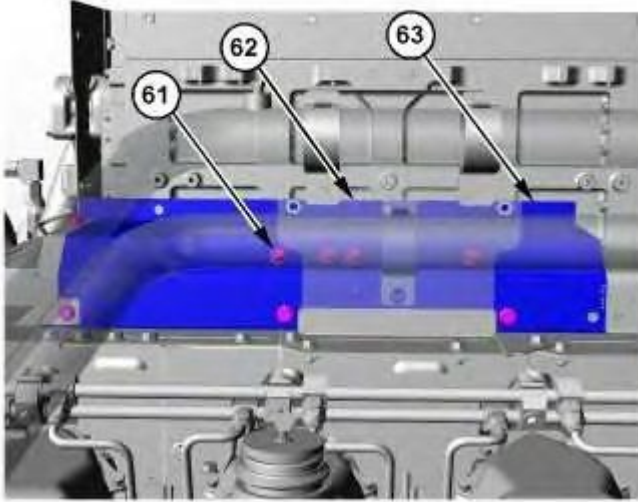

Illustration 23

g06146310

33. Remove six bolts (59), one bolt is not shown.  
34. Remove connector (60).



---

Illustration 24

g06146449

35. Remove eight bolts (61) and remove shields (62) and (63).

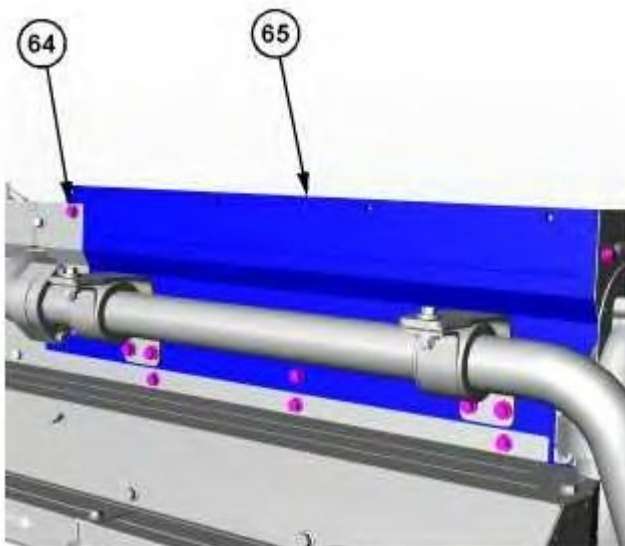

---

Illustration 25

g06147151

36. Remove nine bolts (64) and remove shield (65).
-



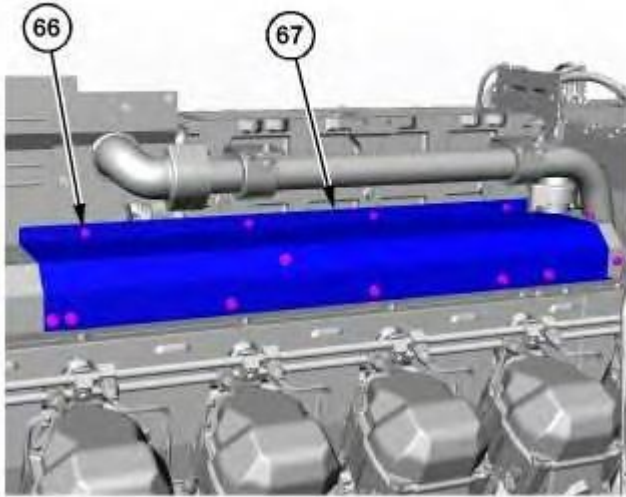

---

Illustration 26

g06147166

37. Remove thirteen bolts (66) and remove shield (67).

---

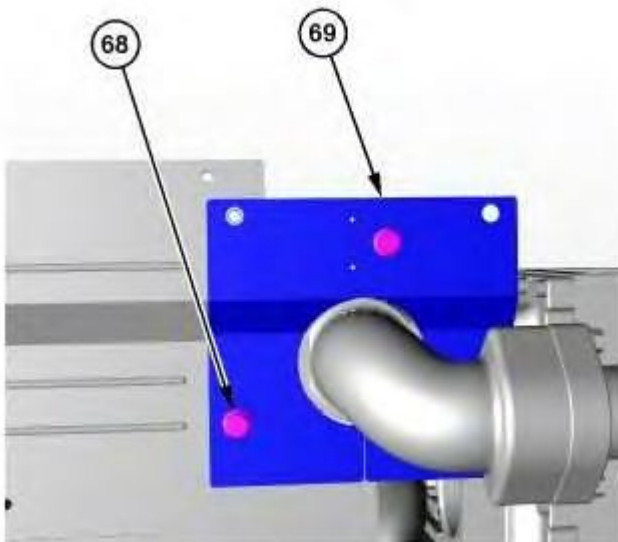

---

Illustration 27

g06147180

38. Remove two bolts (68) and remove shield (69).

---

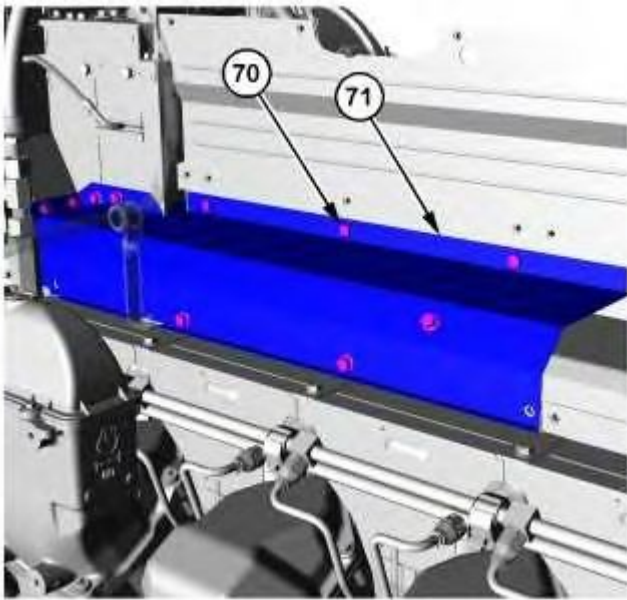

Illustration 28

g06147188

39. Remove ten bolts (70) and remove shield (71).

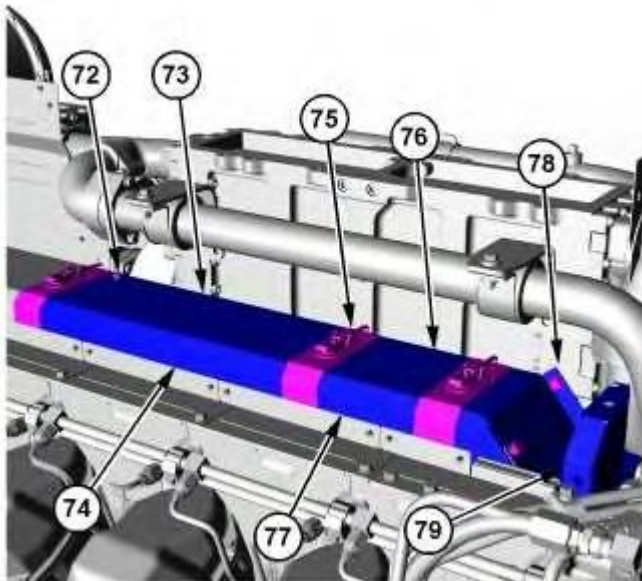

Illustration 29

g06147233

40. Remove four bolts (72), one bolt is not shown.
41. Remove three bracket assemblies (75) and remove shields (73), (74), (76), (77), (78), and (79).



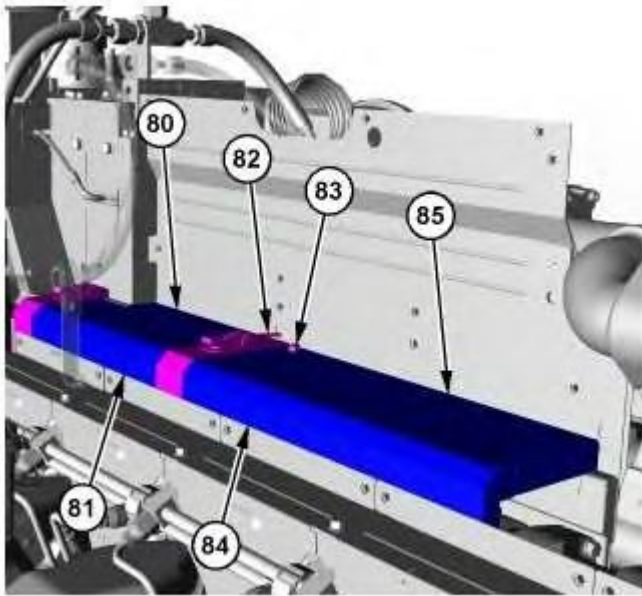

Illustration 30

g06147269

42. Remove one bolt (83) and two brackets (82) to remove shields (80), (81), (84), and (85).

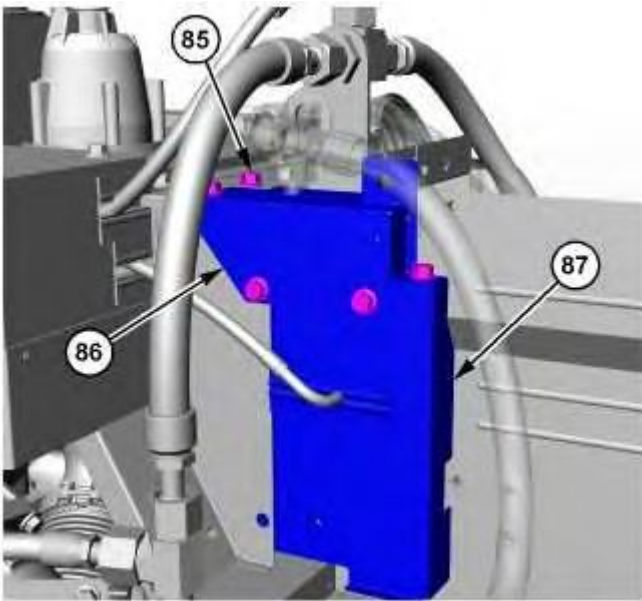

Illustration 31

g06147282

43. Remove five bolts (85) and remove shields (86) and (87).

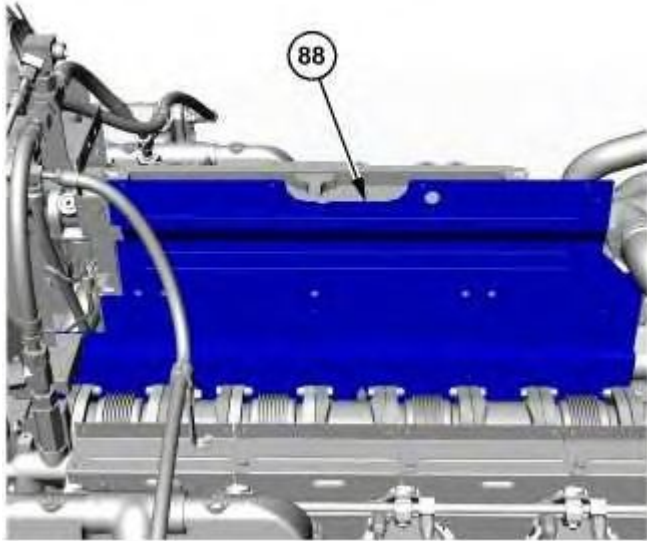

Illustration 32

g06147292

44. Remove shield (88).

---

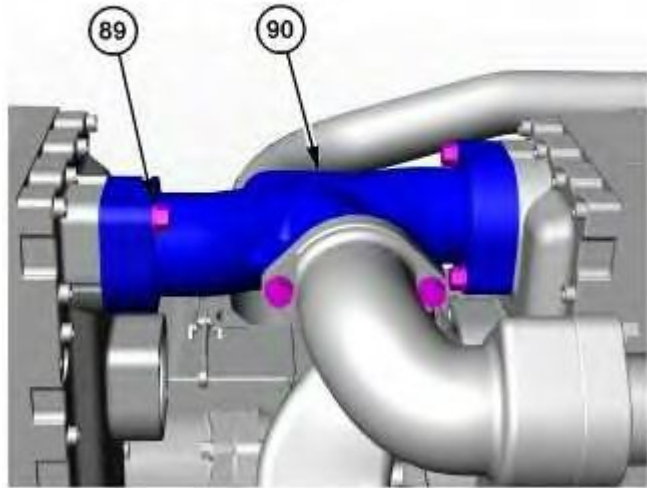

Illustration 33

g06147356

45. Remove six bolts (89), one bolt is not shown.

46. Remove connector (90).

---

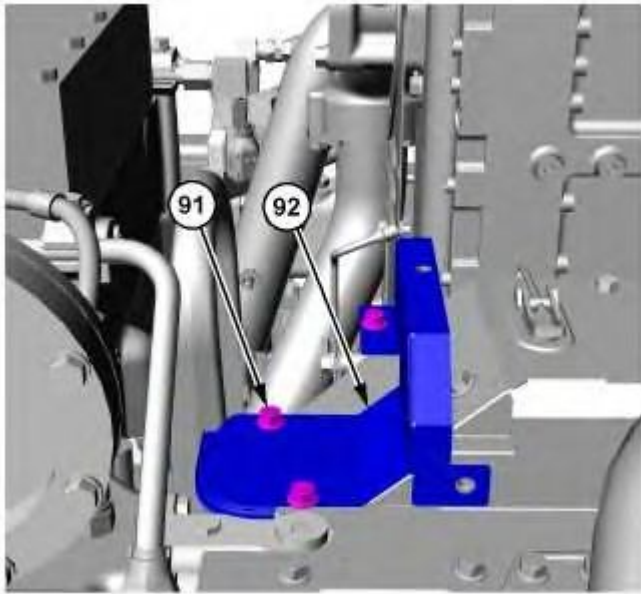

Illustration 34

g06147650

47. Remove three bolts (91) and remove shield (92).

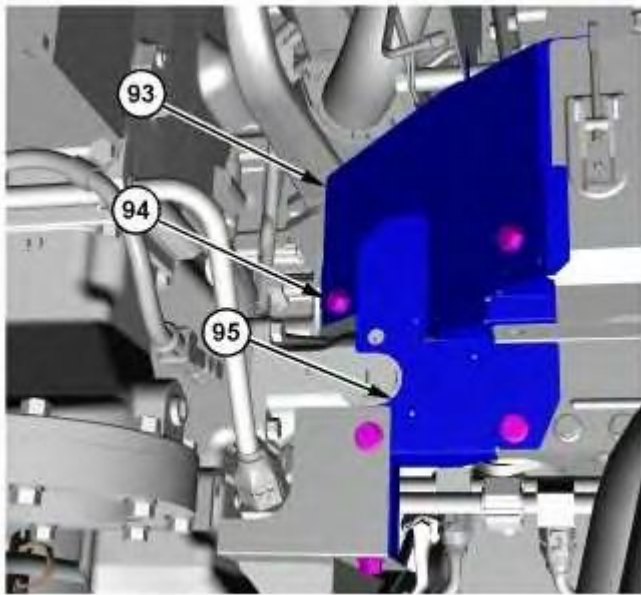

Illustration 35

g06147678

48. Remove five bolts (94) and remove shields (93) and (95).

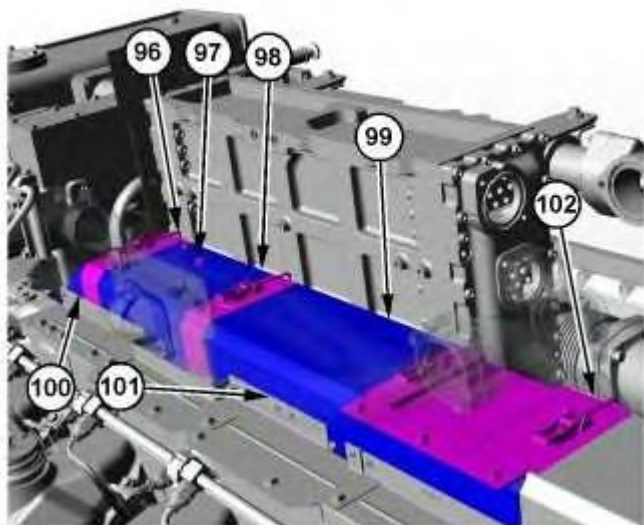

Illustration 36

g06147738

49. Remove five bolts (97) and disconnect four brackets (96).
50. Remove shields (98), (99), (100), and (101).
51. Remove bracket (102).

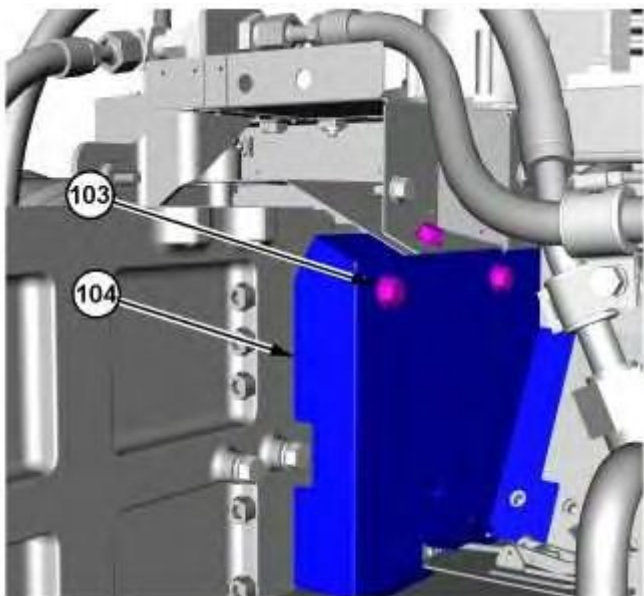

Illustration 37

g06147761

52. Remove three bolts (103) and remove shield (104).

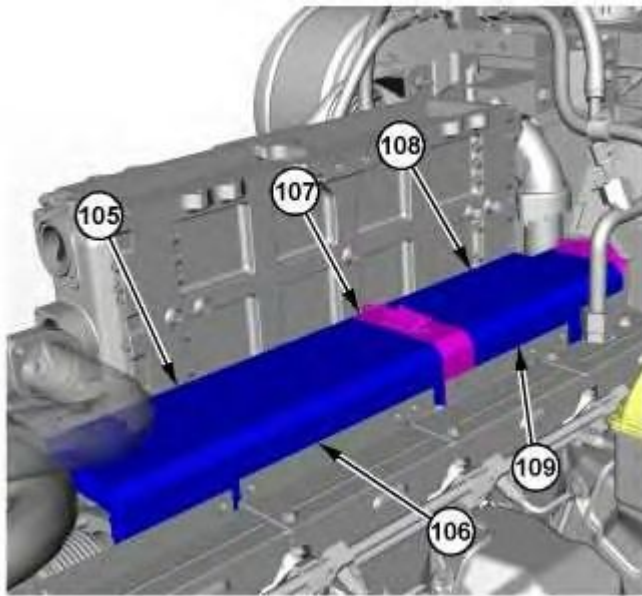

Illustration 38

g06147811

53. Remove two brackets (107) and remove shields (105), (106), (108), and (109).

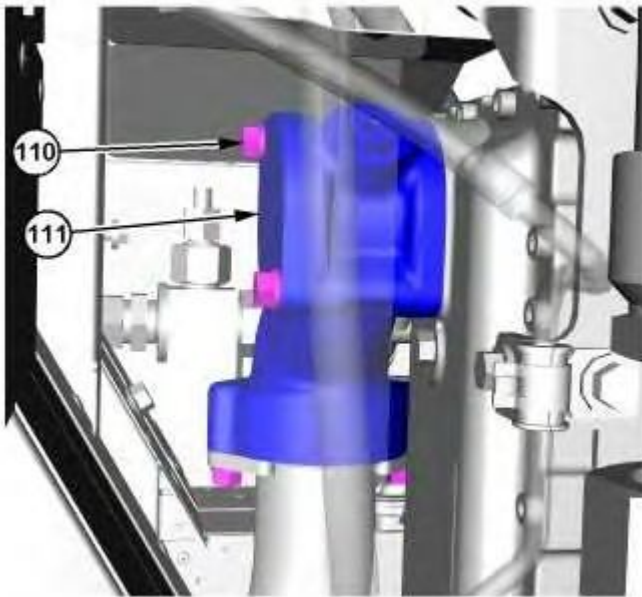

Illustration 39

g06147836

54. Remove four bolts (110) and remove elbow (111).



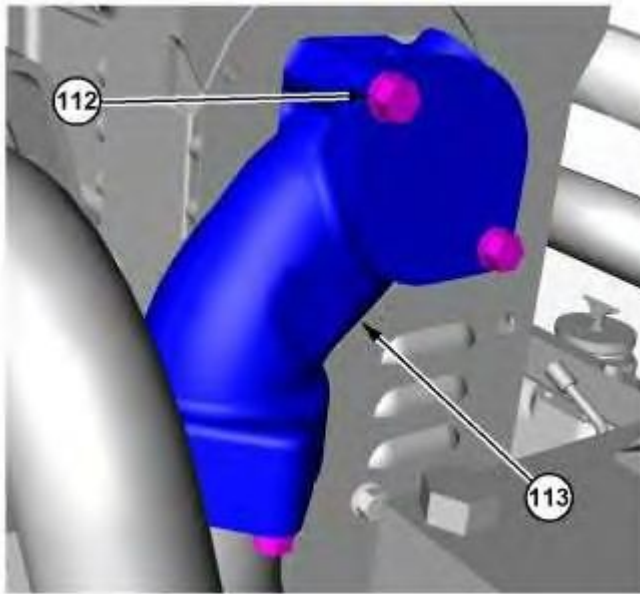

Illustration 40

g06147848

55. Remove four bolts (112) and remove elbow (113).

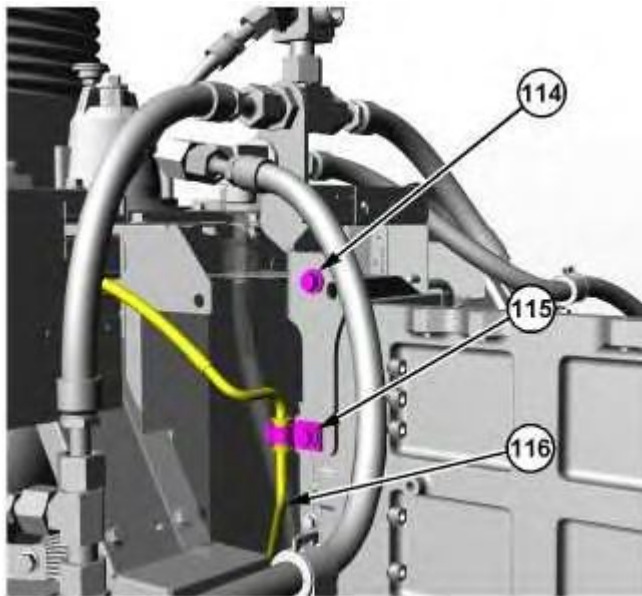

Illustration 41

g06147928

56. Remove 2 bolts (114). One bolt is not shown.
57. Remove bolt and bracket (115) and set tube (116) out of the way.

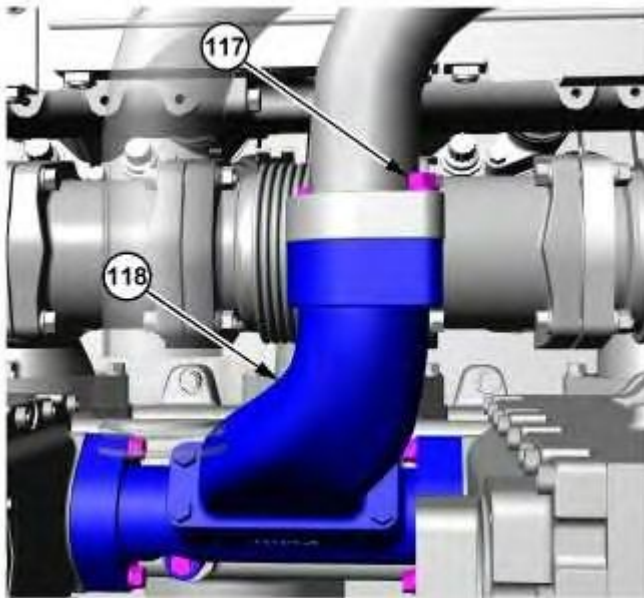

Illustration 42

g06147953

58. Remove seven bolts (117) to remove elbow assembly (118).

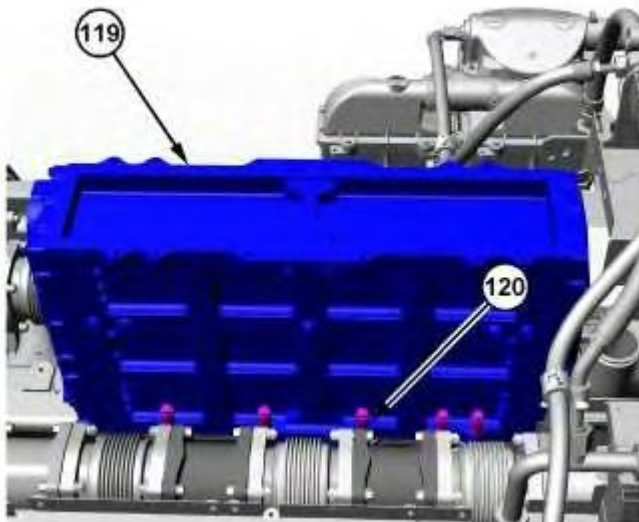

Illustration 43

g06147964

59. Attach a suitable lifting device to the aftercooler (119). The aftercooler weighs approximately 136 kg (300 lb).
60. Remove ten bolts (120) and remove aftercooler (119).

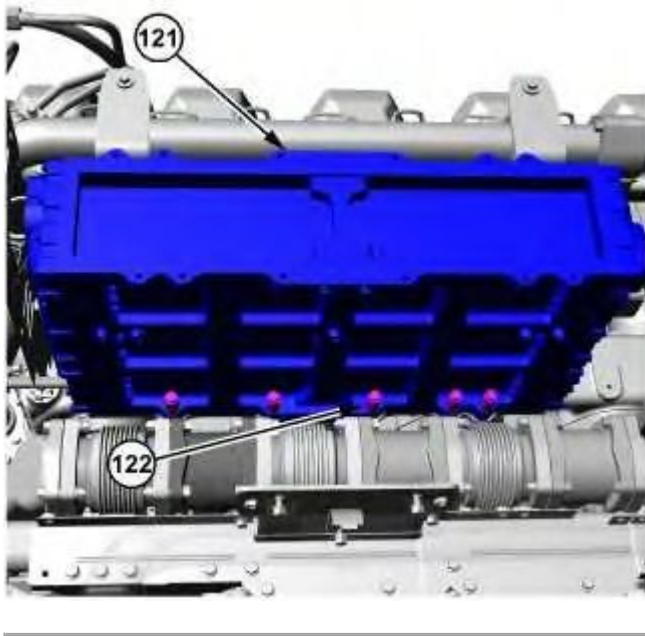

Illustration 44

g06147969

61. Attach a suitable lifting device to the aftercooler (121). The aftercooler weighs approximately 136 kg (300 lb).
62. Remove ten bolts (122) and remove aftercooler (121).

## Installation Procedure

Table 1

Required Tooling			
Tool	Part Number	Part Description	Qty.
A	369-9451	Grease	-
B	5p3931	Anti-Seize Compound	

---

### NOTICE

**Keep all parts clean from contaminants. Contaminants may cause rapid wear and shortened component life.**

---



---

### NOTICE

**Clamp assemblies MUST only be used once. Discard all clamp assemblies after use.**

---



---

## NOTICE

**Bellows assemblies MUST only be used once. Discard all bellows assemblies after use.**

---

---

## NOTICE

**Inspect all seals and O-rings for wear and damage and replace if necessary.**

---

**Note:** Be careful not to damage the fins of the aftercooler cores.

**Note:** Use Tooling (A) to lubricate all seals and O-rings

**Note:** Use Tooling (B) on any bolts with torque specifications. Apply to threads and bearing surfaces.

1. Attach a suitable lifting device to the aftercooler core. The aftercooler core weighs approximately 136 kg (300 lb).

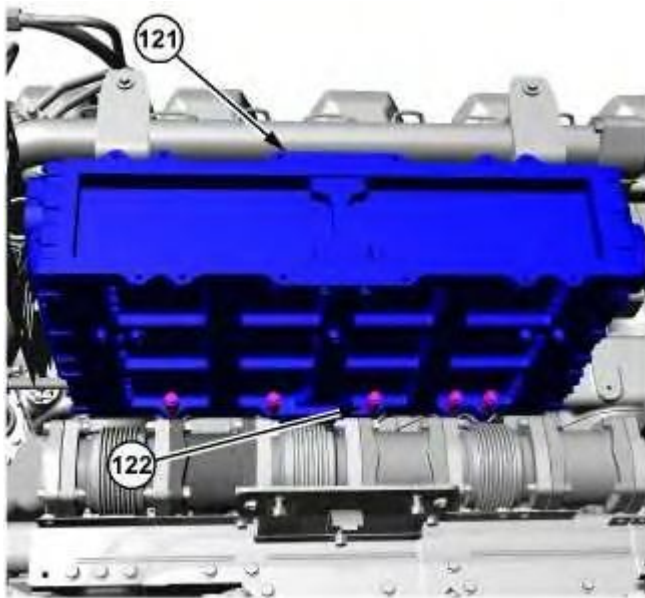

Illustration 45

g06147969

---

Thank you so much for reading.  
Please click the “Buy Now!”  
button below to download the  
complete manual.



After you pay.

You can download the most  
perfect and complete manual in  
the world immediately.

Our support email:

[ebooklibonline@outlook.com](mailto:ebooklibonline@outlook.com)