

Product: BACKHOE LOADER

Model: 416C BACKHOE LOADER 1XR

Configuration: 416C Backhoe Loader Center Pivot, Parallel Lift 1XR00001-02183 (MACHINE) POWERED BY 3054 Engine

## Disassembly and Assembly 3054 Engine for Caterpillar Built Machines

Media Number -SEN6241-13

Publication Date -01/08/2008

Date Updated -04/08/2008

i01605362

# Crankshaft Rear Seal - Install

SMCS - 1161-012

## Installation Procedure

Table 1

Required Tools			
Tool	Part Number	Part Description	Qty
A	9U-6205	Rear Seal Installer	1
	1P-0510	Driver Group	1
B	FT-2806	Alignment Tool	1

---

### NOTICE

**Keep all parts clean from contaminants.**

**Contaminants may cause rapid wear and shortened component life.**

---

## Engines with 14 Bolt Housing Assembly

1. Inspect the condition of the gasket. Replace the gasket, if necessary.
  2. Clean the areas of the parts that will contact each other.
-

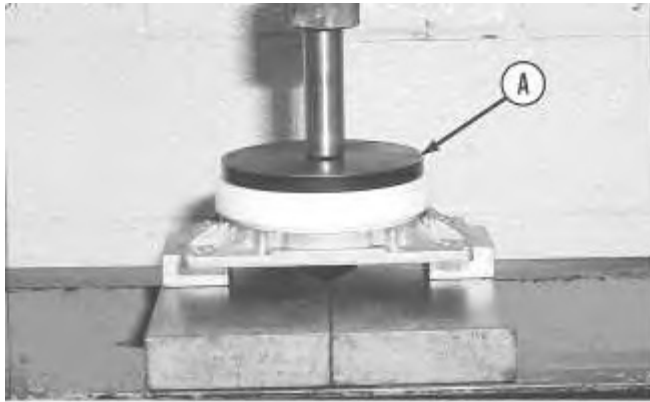

Illustration 1

g00541839

3. Use Tool (A) and a suitable press to install the crankshaft rear seal into the housing. Make sure that you install the seal to the correct depth in the housing. Refer to Specifications, "Crankshaft Seals" for additional information.
4. Lubricate the crankshaft flange and the lip of the crankshaft rear seal with clean engine oil.
5. Install Tool (A) onto the crankshaft flange.
6. Put the new gasket for the housing in position on the dowels in the cylinder block.

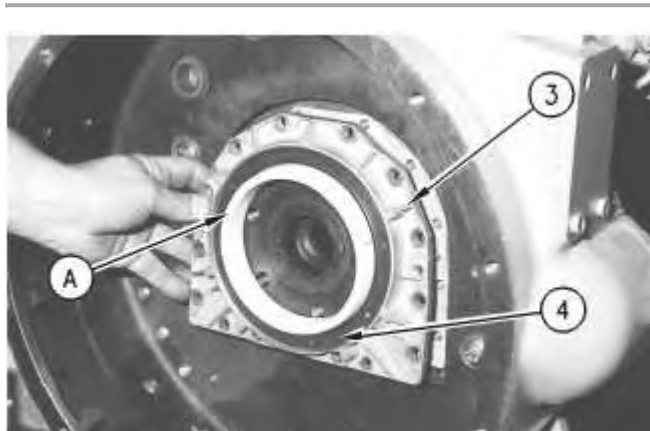

Illustration 2

g00606404

7. Carefully place housing (3) and crankshaft rear seal (4) over Tool (A) .
8. Position housing (3) on the dowels in the cylinder block.
9. Remove Tool (A) .

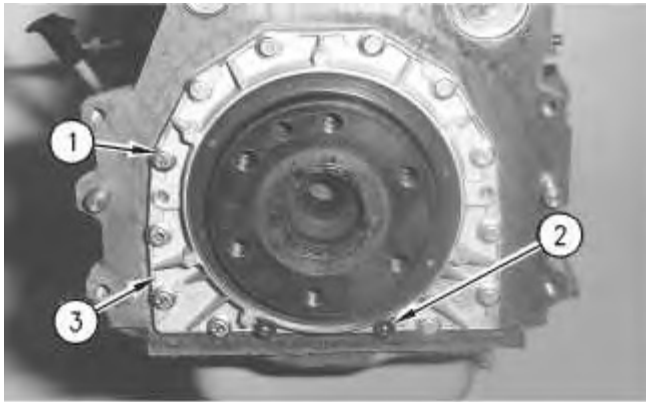

Illustration 3

g00606340

The flywheel housing has been removed for photographic purposes only.

10. Install bolts (1) and socket head bolts (2) that fasten housing (3) to the cylinder block.
11. Tighten all of the bolts to a torque of 22 N·m (16 lb ft).

## Engines with 10 Bolt Housing Assembly

**Note:** The 10 bolt housing assembly is manufactured as a one-piece assembly. The 10 bolt housing assembly is NOT adaptable to engines that have the 14 bolt housing assembly.

1. Ensure that all parts and surfaces of the engine block are clean and free from oil, grease, and dirt.

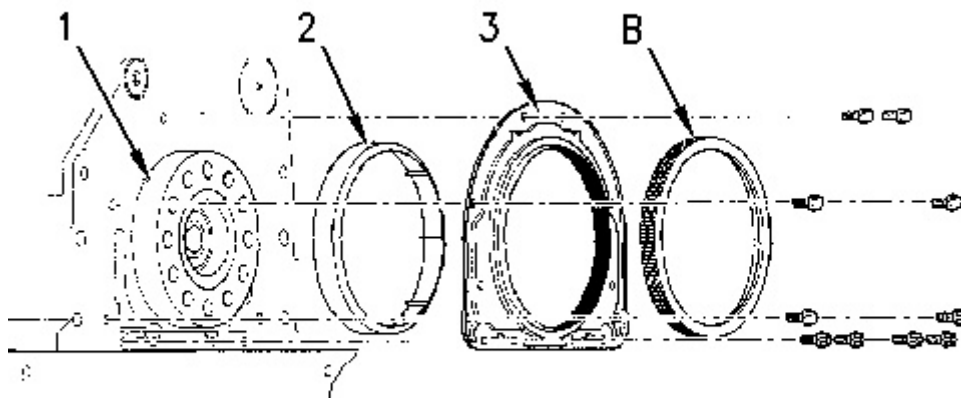

Illustration 4

g00831176

**Note:** The crankshaft rear seal is lubricated. There is no need to lubricate the seal or the crankshaft flange before installation.

2. Place housing assembly (3) on crankshaft flange (1) until the housing assembly contacts the cylinder block face. Plastic sleeve (2) will push out of the housing assembly. Discard the plastic sleeve after the housing assembly is installed.
3. Place Tool (B) over housing assembly (3). This will center the housing assembly onto the crankshaft flange.

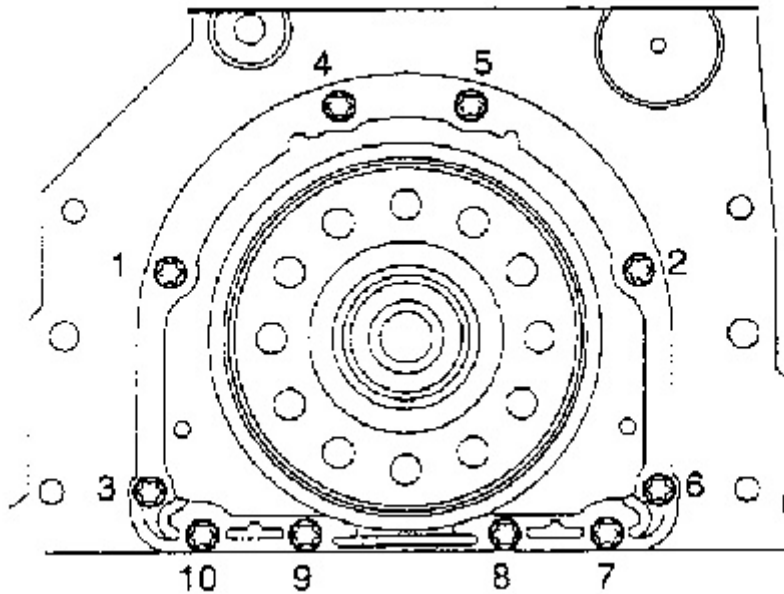

Illustration 5

g00830867

4. Install the bolts with Tool (B) in position in order to fasten housing assembly (3) to the cylinder block. Tighten bolts 1 and 2 to a torque of 22 N·m (16 lb ft).
5. Remove Tool (B). Tighten the remaining bolts in sequence to a torque of 22 N·m (16 lb ft).

**End By:** Install the flywheel. Refer to Disassembly and Assembly, "Flywheel - Install".

---

Thank you so much for reading.  
Please click the “Buy Now!”  
button below to download the  
complete manual.



After you pay.

You can download the most  
perfect and complete manual in  
the world immediately.

Our support email:

[ebooklibonline@outlook.com](mailto:ebooklibonline@outlook.com)