

Product: TRUCK

Model: 789B TRUCK 7EK

Configuration: 789B Off-HighwayTruck 7EK00001-UP (MACHINE) POWERED BY 3516 Engine

## Disassembly and Assembly

### 3500 and 3500B High Displacement Engines for Caterpillar Built Machines

Media Number -SEN1126-33

Publication Date -01/07/2015

Date Updated -14/09/2018

i02517352

## Flywheel Housing - Remove

SMCS - 1157-011

## Removal Procedure

Table 1

Required Tools			
Tool	Part Number	Part Description	Qty
A	8B-7548	Push-Puller Tool Group	1
	8B-7559	Adapter	2
	8H-0684	Ratchet Wrench	1
	8B-7561	Step Plate	3
B	138-7573	Link Bracket	2
C	169-5464	Quick Cure Primer	-

### Start By:

- a. Remove the starting motors. Refer to Disassembly and Assembly, "Air Starting Motor - Remove" or Disassembly and Assembly, "Electric Starting Motor - Remove and Install".
- b. If the exhaust elbow is attached to the flywheel housing, remove the exhaust elbow and remove the bracket for the exhaust elbow. Refer to Disassembly and Assembly, "Exhaust Elbow - Remove and Install".
- c. Remove the engine oil pan. Refer to Disassembly and Assembly, "Engine Oil Pan - Remove".

---

**NOTICE**

**Keep all parts clean from contaminants.**

**Contaminants may cause rapid wear and shortened component life.**

---

1. Use the timing pins in order to properly time the engine. Refer to Testing and Adjusting, "Camshaft Timing". Refer to Testing and Adjusting, "Finding the Top Center Position for the No. 1 Piston".
  2. Remove the crankshaft rear seal and the wear sleeve. Refer to Disassembly and Assembly, "Crankshaft Rear Seal and Wear Sleeve - Remove".
  3. Remove the camshaft covers and gaskets.
  4. Remove the bolts and plates from the camshafts.
- 

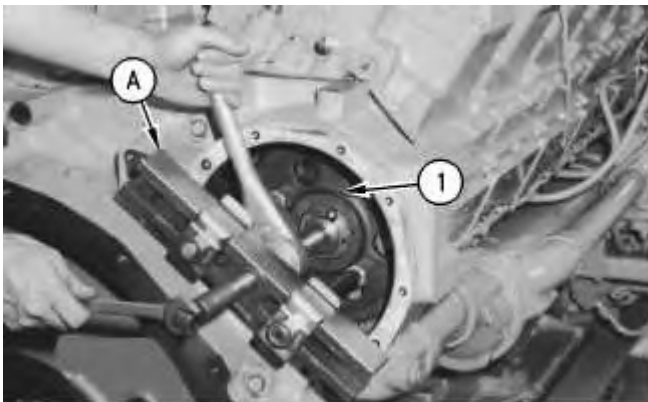

Illustration 1

g00912881

5. Use Tooling (A) in order to remove camshaft drive gears (1).
- 

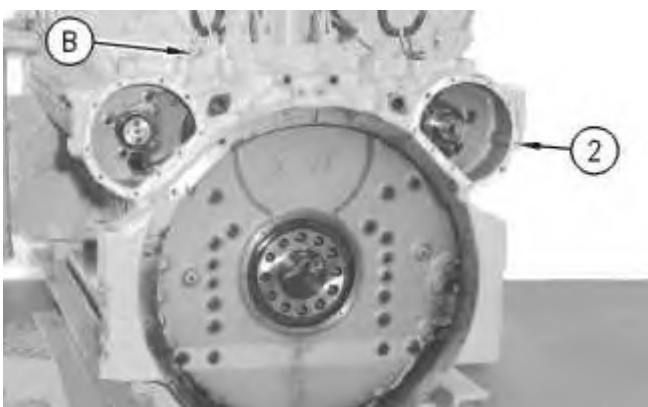

Illustration 2

g00912883

6. Install Tooling (B) into flywheel housing (2). Attach a suitable lifting device to Tooling (B). The weight of flywheel housing (2) is approximately 251 kg (553 lb).
7. Remove the bolts and remove flywheel housing (2) and the gasket.

8. After removing flywheel housing (2), clean the mating surface of the cylinder block and the mating surface of the flywheel housing with Tooling (C). If necessary, use a gasket scraper and a solvent in order to remove any residual gasket material. Both mating surfaces must be clean, dry, and free of any oil before installation.
-

Product: TRUCK

Model: 789B TRUCK 7EK

Configuration: 789B Off-HighwayTruck 7EK00001-UP (MACHINE) POWERED BY 3516 Engine

## Disassembly and Assembly

### 3500 and 3500B High Displacement Engines for Caterpillar Built Machines

Media Number -SEN1126-33

Publication Date -01/07/2015

Date Updated -14/09/2018

i06304711

## Flywheel Housing - Install

SMCS - 1157-012

### Installation Procedure

Table 1

Required Tools			
Tool	Part Number	Part Description	Qty
B	138-7573	Link Bracket	2
D	-	Guide Bolts 5/8 - 11 NC by 8 inch	2
E	- <sup>(1)</sup>	Loctite 5127	-

<sup>(1)</sup> EAME

---

### NOTICE

**Keep all parts clean from contaminants.**

**Contaminants may cause rapid wear and shortened component life.**

---

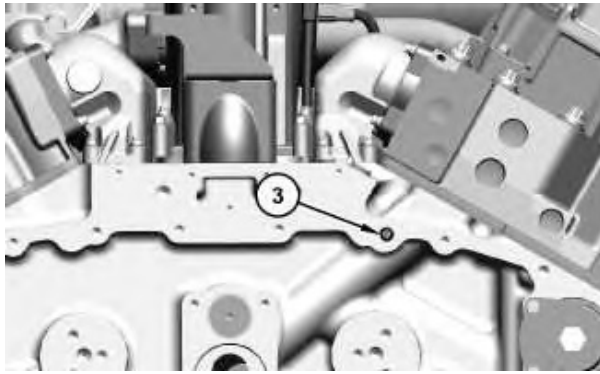

Illustration 1

g03896638

**Note:** Refer to Engine News 27 March 2006, "Sealing and Installing the Flywheel Housing" for more information.

1. Install O-ring seal (3) on the dowel.

**Note:** If the dowel needs to be replaced, the installed height is  $6.0 \pm 0.5$  mm ( $0.24 \pm 0.02$  inch).

2. Ensure that the mating surface of the flywheel housing and the engine block are clean. Both mating surfaces must be clean, dry, and free of any oil before Tooling (E) is applied.

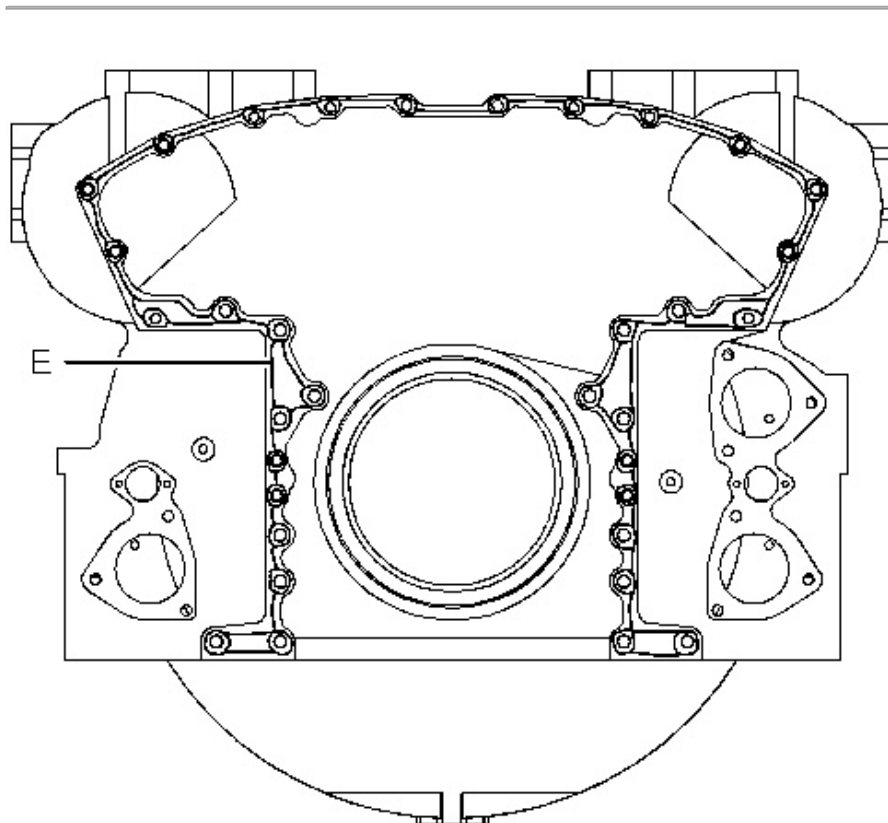

Illustration 2

g01259519

3. Apply a 6.0 mm (0.25 inch) bead of Tooling (E) to the mating surface of the flywheel housing. Refer to Illustration 2.

4. Install Tooling (D) into the cylinder block.

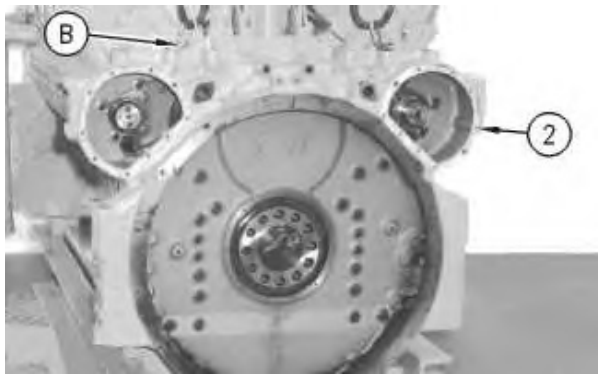

Illustration 3

g00912883

5. Install Tooling (B) onto flywheel housing (2) . Attach a suitable lifting device to Tooling (B) . The weight of flywheel housing (2) is approximately 251 kg (553 lb).
6. Lift flywheel housing (2) into position onto Tooling (D) .

**Note:** For the correct positions of the bolts, see Illustration 4 or Illustration 5.

7. Install the bolts and the hard washers that secure flywheel housing (2) to the cylinder block. Remove Tooling (D) and install the remaining bolts and the remaining hard washers.

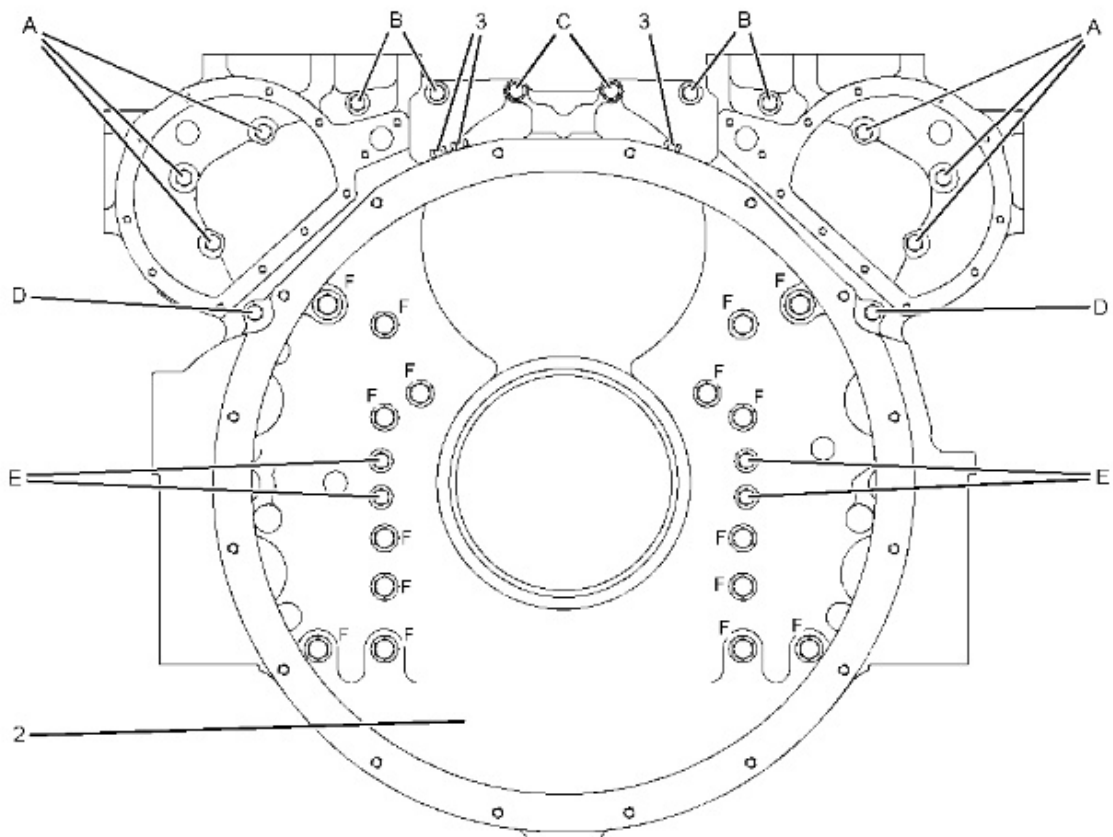

- (A) 1/2 - NC
- (B) 1/2 - NC
- (C) 1/2 - NC
- (D) 1/2 - NC
- (E) 1/2 - NC
- (F) 5/8 - NC

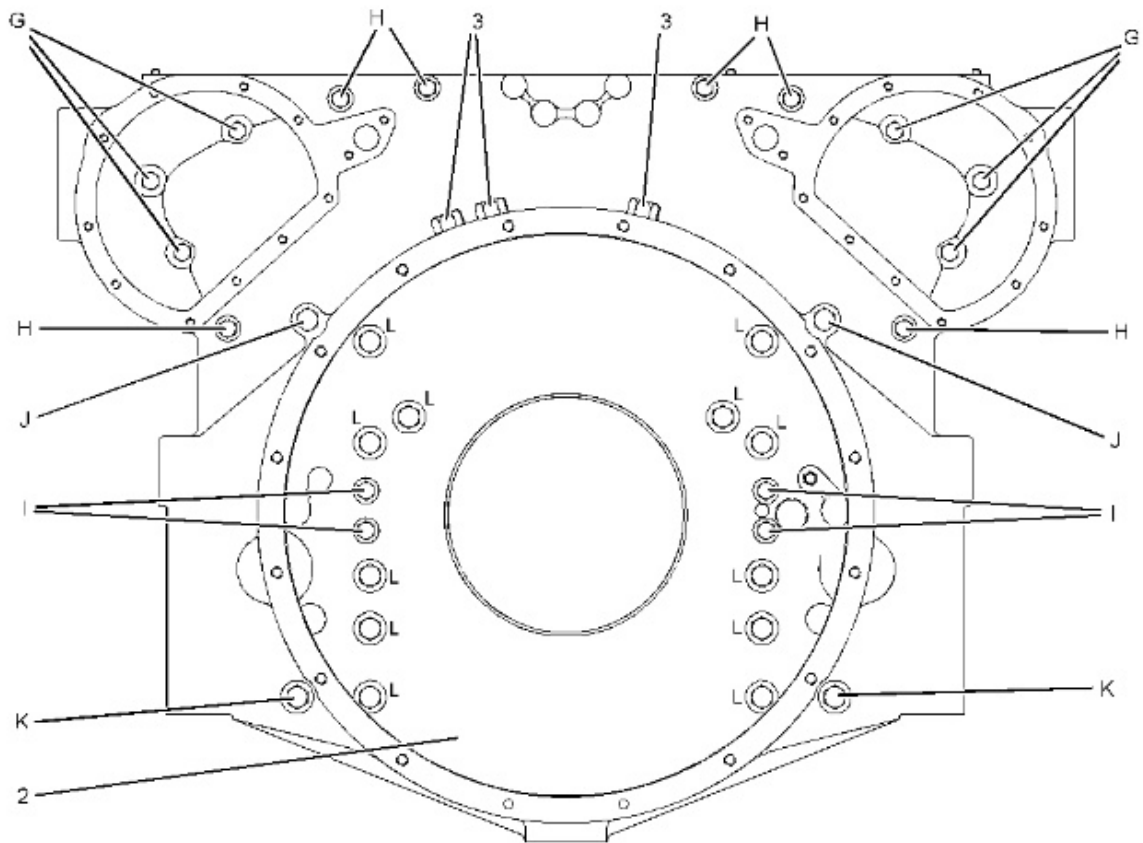

Illustration 5

- (G) 1/2 - NC
- (H) 1/2 - NC
- (I) 1/2 - NC
- (J) 5/8 - NC
- (K) 5/8 - NC
- (L) 5/8 - NC

8. Tighten the bolts in flywheel housing (2) evenly. Tighten the 1/2 - NC bolts to a torque of  $135 \pm 20$  N·m ( $100 \pm 15$  lb ft). Tighten the 5/8 - NC bolts to a torque of  $270 \pm 40$  N·m ( $200 \pm 30$  lb ft). The torque for plugs (3) is  $70 \pm 15$  N·m ( $50 \pm 11$  lb ft).

9. Install the crankshaft rear seal and the wear sleeve. Refer to Disassembly and Assembly, "Crankshaft Rear Seal and Wear Sleeve - Install".
10. Place the camshaft timing pins in position. Place the timing bolt in the flywheel with the No. 1 piston at the top center position on the compression stroke.



Illustration 6

g01226902

11. Use the following procedure in order to install camshaft drive gears (1) .
  - a. Clean the taper of the camshaft and the tapered bore of the camshaft gear with a lint free cloth saturated with solvent to remove oil. Clean the parts again with a lint free alcohol wipe in order to remove any residue. The alcohol wipe will dirty after cleaning the parts. Clean the parts again with a lint free alcohol wipe until no residue is left on the alcohol wipe.

**Note:** The taper of the camshaft and the tapered bore of the camshaft gear must be clean, dry, and free of residue before assembly.
  - b. Ensure that the camshaft timing pins and the timing pin for the flywheel are installed.
  - c. Place camshaft drive gears (1) in position. Remove the backlash by rotating the gears in the opposite direction of camshaft rotation.

**Note:** For "Standard Rotation" engines, turn the camshaft drive gears COUNTERCLOCKWISE. For "Reverse Rotation" engines, turn the camshaft drive gears CLOCKWISE.
  - d. Install the bolt and the plate for the camshafts.
  - e. Install the bolt and the timing ring for the camshafts. Ensure that the hole in the timing ring is properly seated on the locating pin.
  - f. Tighten the bolts to a torque of 360 N·m (265 lb ft).
  - g. Place a Mark on the bolts.
  - h. Place a driver against the retaining plate of the camshaft gear. Strike the driver solidly with a hammer 3 to 4 times.
  - i. Tighten the bolts again to a torque of 360 N·m (265 lb ft).
  - j. Repeat Steps 11.h and 11.i until the Mark has turned at least 90 degrees.
12. Remove the timing pins from the camshafts and the flywheel.



13. Install the gaskets and camshaft covers.

**End By:**

- a. Install the engine oil pan. Refer to Disassembly and Assembly, "Engine Oil Pan - Install".
  - b. If the exhaust elbow was removed, install the exhaust elbow. Refer to Disassembly and Assembly, "Exhaust Elbow - Remove and Install".
  - c. Install the starting motors. Refer to Disassembly and Assembly, "Air Starting Motor - Install" or Disassembly and Assembly, "Electric Starting Motor - Remove and Install".
-

Product: TRUCK

Model: 789B TRUCK 7EK

Configuration: 789B Off-HighwayTruck 7EK00001-UP (MACHINE) POWERED BY 3516 Engine

## **Disassembly and Assembly**

### **3500 and 3500B High Displacement Engines for Caterpillar Built Machines**

Media Number -SEN1126-33

Publication Date -01/07/2015

Date Updated -14/09/2018

i02928334

## **Engine Oil Sequence Valves - Remove and Install**

SMCS - 1332-010

### **Removal Procedure**

#### **Start By:**

- a. Remove the front drive housing. Refer to Disassembly and Assembly, "Front Drive Housing - Remove and Install" or Disassembly and Assembly, "Drive Housing (Front) - Remove and Install".
- b. Remove the flywheel housing. Refer to Disassembly and Assembly, "Flywheel Housing - Remove".

---

#### **NOTICE**

**Keep all parts clean from contaminants.**

**Contaminants may cause rapid wear and shortened component life.**

---

---

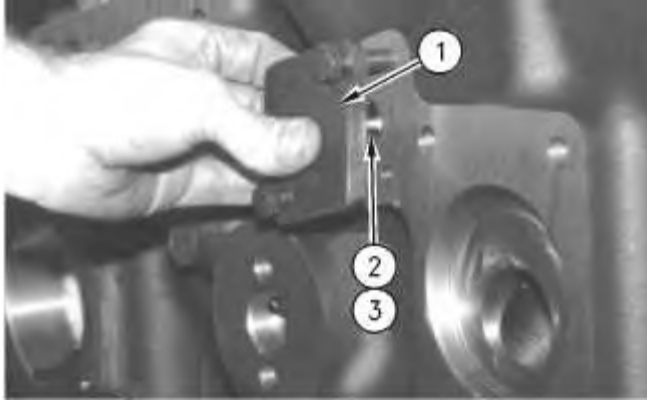

Illustration 1

g00912963

## **WARNING**

**Personal injury can result from parts and/or covers under spring pressure.**

**Spring force will be released when covers are removed.**

**Be prepared to hold spring loaded covers as the bolts are loosened.**

1. Remove cover (1) from the front of the cylinder block.
2. Remove plunger assembly (2) and spring (3) from the front of the cylinder block.

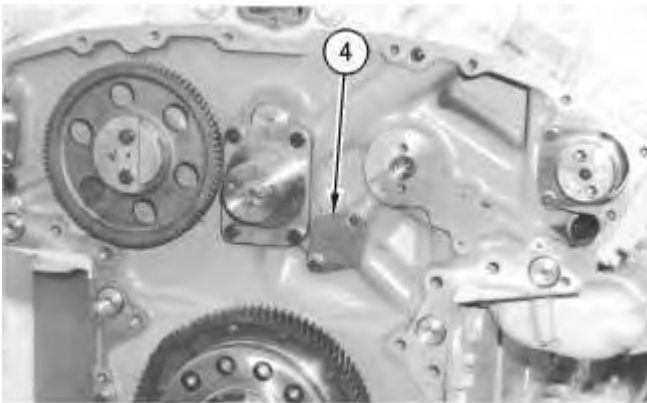

Illustration 2

g00912966

## **WARNING**

**Personal injury can result from parts and/or covers under spring pressure.**

**Spring force will be released when covers are removed.**

**Be prepared to hold spring loaded covers as the bolts are loosened.**

---

3. Remove the idler gear and the shaft. Remove cover (4) on the rear of the cylinder block.

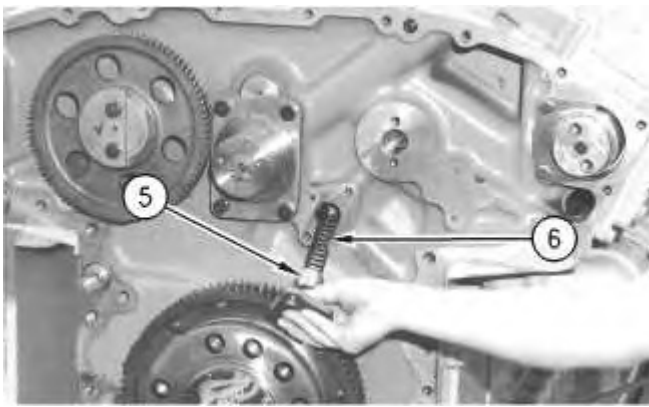

Illustration 3

g00912969

4. Remove plunger assembly (5) and spring (6) from the rear of the cylinder block.

## **Installation Procedure**

---

### **NOTICE**

**Keep all parts clean from contaminants.**

**Contaminants may cause rapid wear and shortened component life.**

---

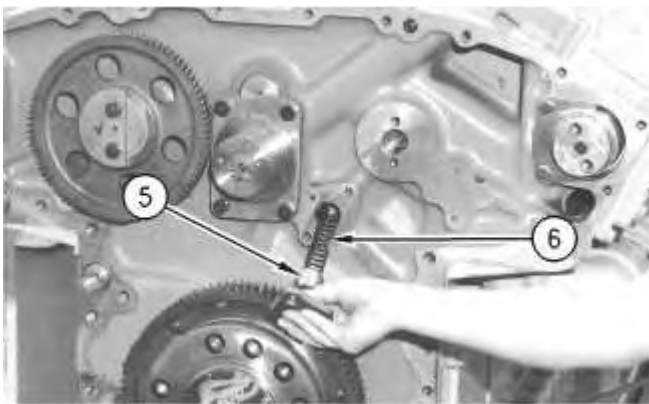

Illustration 4

g00912969

1. Place clean engine oil on spring (6) and plunger assembly (5).
2. Install spring (6) and plunger assembly (5).

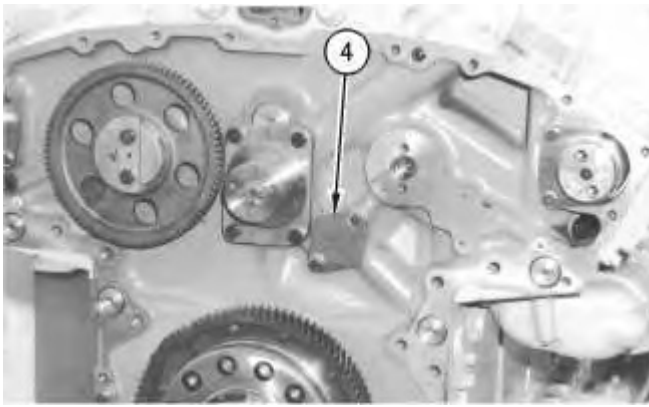

Illustration 5

g00912966

 **WARNING**

**Improper assembly of parts that are spring loaded can cause bodily injury.**

**To prevent possible injury, follow the established assembly procedure and wear protective equipment.**

---

3. Install cover (4) on the rear of the cylinder block. Install the idler gear and the shaft.

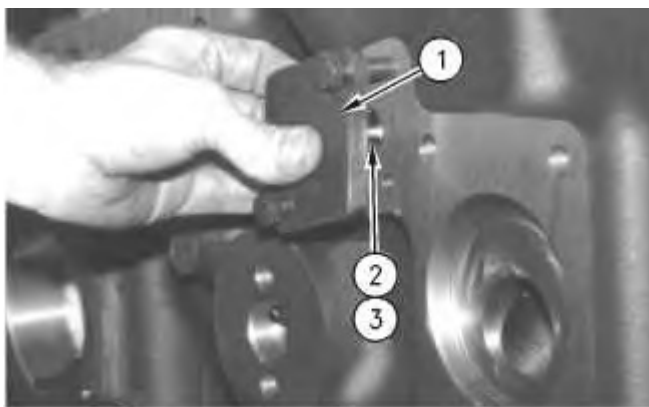

Illustration 6

g00912963

 **WARNING**

**Improper assembly of parts that are spring loaded can cause bodily injury.**

**To prevent possible injury, follow the established assembly procedure and wear protective equipment.**

---

4. Place clean engine oil on spring (3) and plunger assembly (2).
5. Install spring (3) and plunger assembly (2) on the front of the cylinder block.
6. Install cover (1) on the front of the cylinder block.

**End By:**

- a. Install the flywheel housing. Refer to Disassembly and Assembly, "Flywheel Housing - Install".
  - b. Install the front drive housing. Refer to Disassembly and Assembly, "Front Drive Housing - Remove and Install" or Disassembly and Assembly, "Drive Housing (Front) - Remove and Install".
-

Product: TRUCK

Model: 789B TRUCK 7EK

Configuration: 789B Off-HighwayTruck 7EK00001-UP (MACHINE) POWERED BY 3516 Engine

## Disassembly and Assembly

### 3500 and 3500B High Displacement Engines for Caterpillar Built Machines

Media Number -SEN1126-33

Publication Date -01/07/2015

Date Updated -14/09/2018

i07085932

## Gear Group (Rear) - Remove

SMCS - 1206-011; 1212-011

### Removal Procedure

Table 1

Required Tools			
Tool	Part Number	Part Description	Qty
A	1P-0520	Driver Group	1

#### Start By:

- Remove the flywheel housing. Refer to Disassembly and Assembly, "Flywheel Housing - Remove".

---

#### NOTICE

**Keep all parts clean from contaminants.**

**Contaminants may cause rapid wear and shortened component life.**

---

---

#### NOTICE

**Care must be taken to ensure that fluids are contained during performance of inspection, maintenance, testing, adjusting, and repair of the product. Be prepared to collect the fluid with suitable containers before opening any compartment or disassembling any component containing fluids.**

Refer to Special Publication, NENG2500, "Dealer Service Tool Catalog" for tools and supplies suitable to collect and contain fluids on Cat<sup>®</sup> products.

Dispose of all fluids according to local regulations and mandates.

---

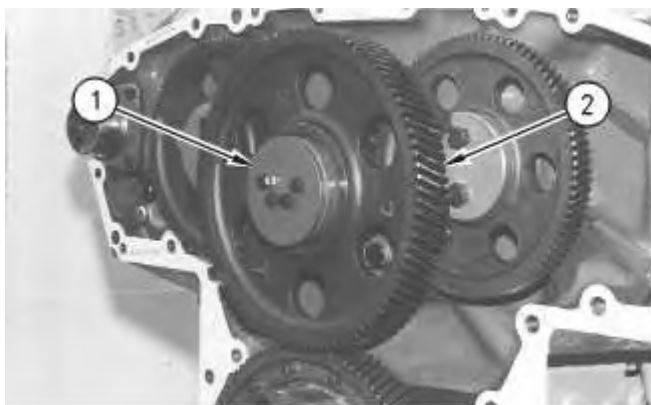

Illustration 1

g00913045

1. Remove plate (1) and gear (2).
- 



Illustration 2

g00913049

2. Use Tooling (A) and a suitable press to remove bearing (3) from gear (2).
-



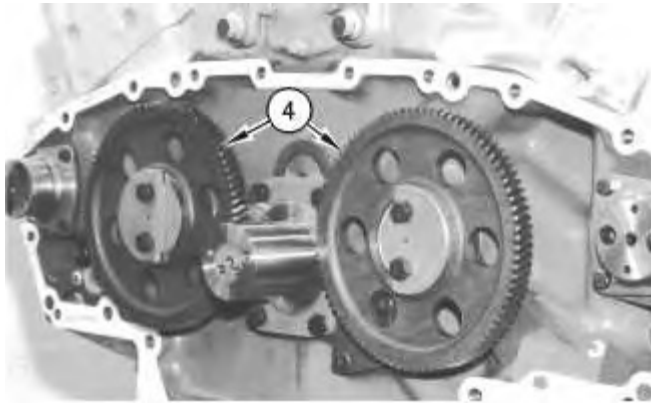

Illustration 3

g00913054

3. Remove the bolts, the washers, and camshaft idler gears (4).

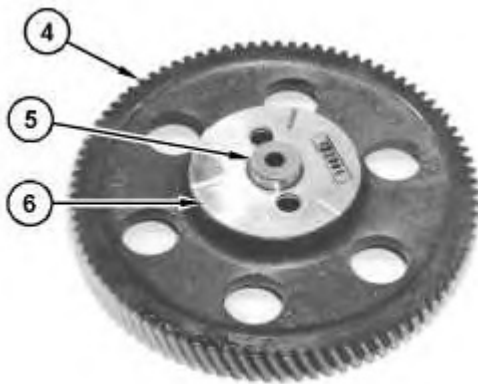

Illustration 4

g01051669

4. Remove washers (6) and shafts (5) from camshaft idler gears (4).
5. Use Tooling (A) and a suitable press to remove bearings from camshaft idler gears (4).



Illustration 5

g00913136

6. Remove the bolts from shaft (7) and remove shaft (7).

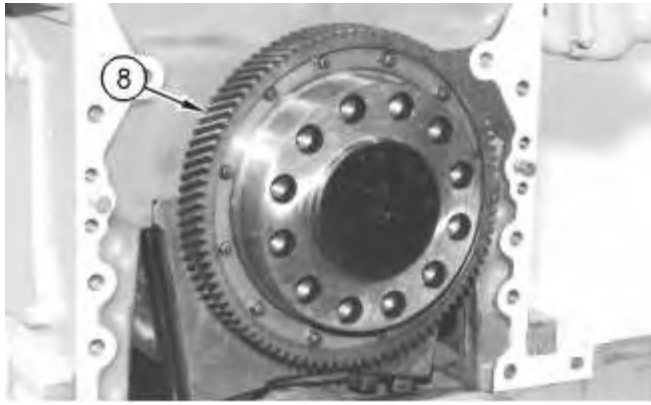

---

Illustration 6

g00913137

7. Remove the bolts and crankshaft gear (8) from the end of the crankshaft.
-

Product: TRUCK

Model: 789B TRUCK 7EK

Configuration: 789B Off-HighwayTruck 7EK00001-UP (MACHINE) POWERED BY 3516 Engine

## Disassembly and Assembly

### 3500 and 3500B High Displacement Engines for Caterpillar Built Machines

Media Number -SEN1126-33

Publication Date -01/07/2015

Date Updated -14/09/2018

i04014109

## Gear Group (Rear) - Install

SMCS - 1206-012; 1212-012

### Installation Procedure

Table 1

Required Tools			
Tool	Part Number	Part Description	Qty
A	1P-0520	Driver Gp	1

---

#### NOTICE

**Keep all parts clean from contaminants.**

**Contaminants may cause rapid wear and shortened component life.**

---

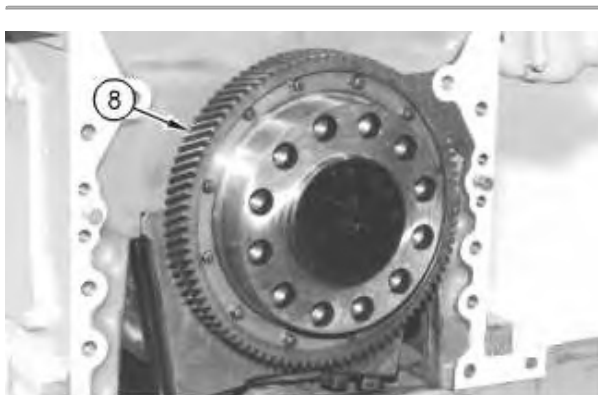

Illustration 1

g00913137

1. Install crankshaft gear (8) and the bolts.

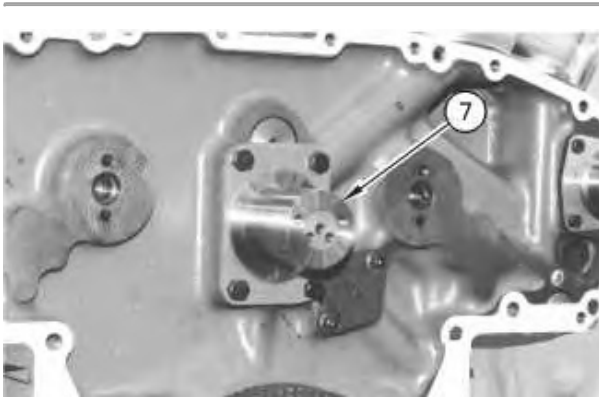

Illustration 2

g00913136

2. Install shaft (7) and the bolts. The torque for the bolts is  $140 \pm 10 \text{ N}\cdot\text{m}$  ( $105 \pm 5 \text{ lb ft}$ ).

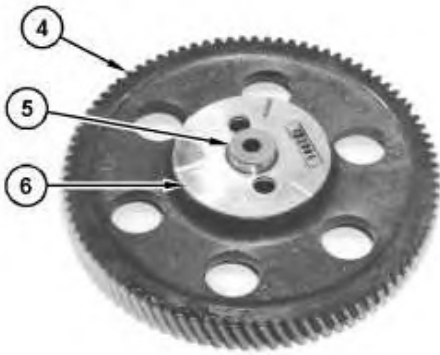

Illustration 3

g01051669

---

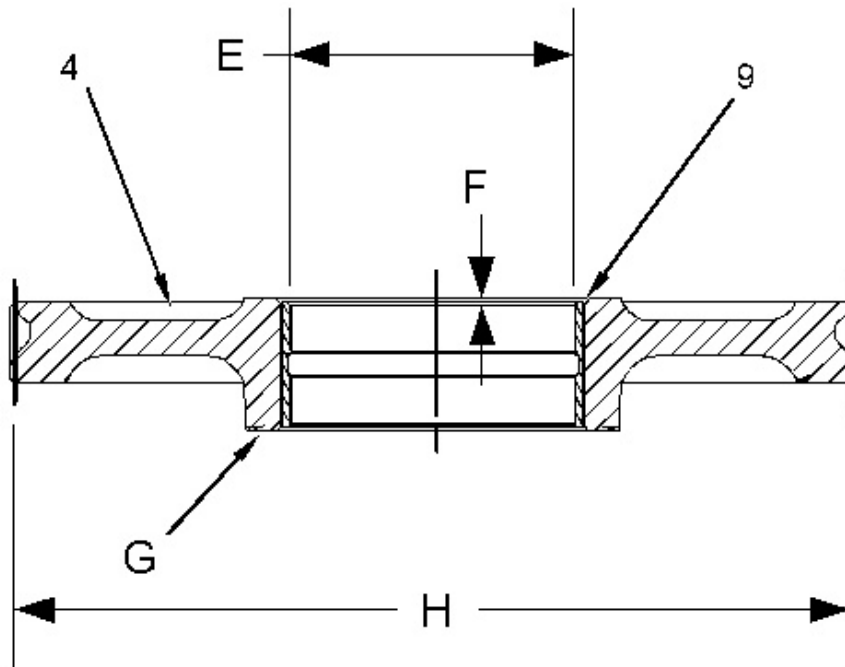

Illustration 4

g01068502

(4) Camshaft Idler Gear. (9) Bearing. (E)  $81.060 \pm 0.010$  mm ( $3.1913 \pm 0.0004$  inch). (F)  $1.00 \pm 0.25$  mm ( $0.040 \pm 0.010$  inch).

3. Use Tooling (A) and a suitable press to install the bearings in camshaft idler gears (4) . Install bearing (9) into gear (4) to Depth (F) , as shown.

4. Machine the inside diameter of bearing (9) to Dimension (E) , as shown.

**Note:** The surface finish of Bore (E) must be 0.8 micrometers. Pitch Diameter (H) must be concentric with a total indicator reading of 0.12 mm (0.005 inch). Surface (G) of gear (4) must be square with Bore (E) within 0.05 mm (0.002 inch).

5. Place clean engine oil on the bearings and install shafts (5) with washers (6) on camshaft idler gears (4) .

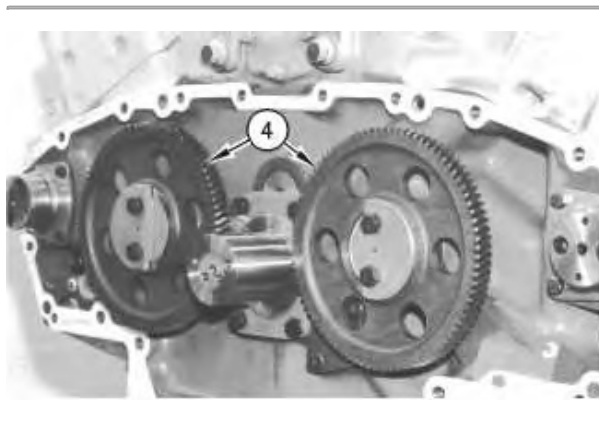

Thank you so much for reading.  
Please click the “Buy Now!”  
button below to download the  
complete manual.



After you pay.

You can download the most  
perfect and complete manual in  
the world immediately.

Our support email:

[ebooklibonline@outlook.com](mailto:ebooklibonline@outlook.com)