

Product: TRUCK

Model: 789D TRUCK SPD

Configuration: 789D Off-Highway Truck SPD00001-UP (MACHINE) POWERED BY 3516 Engine

## Disassembly and Assembly

### 3500 and 3500B High Displacement Engines for Caterpillar Built Machines

Media Number -SEN1126-33

Publication Date -01/07/2015

Date Updated -14/09/2018

i02415328

## Electronic Unit Injector - Remove

SMCS - 1290-011

### Removal Procedure

Table 1

Required Tools			
Tool	Part Number	Part Description	Qty
A	5F-4764	Pry Bar	1

#### Start By:

- a. Remove the rocker shaft assembly and the pushrods. Refer to Disassembly and Assembly, "Rocker Shaft Assembly and Push Rods - Remove".

---

### NOTICE

**Keep all parts clean from contaminants.**

**Contaminants may cause rapid wear and shortened component life.**

---

---

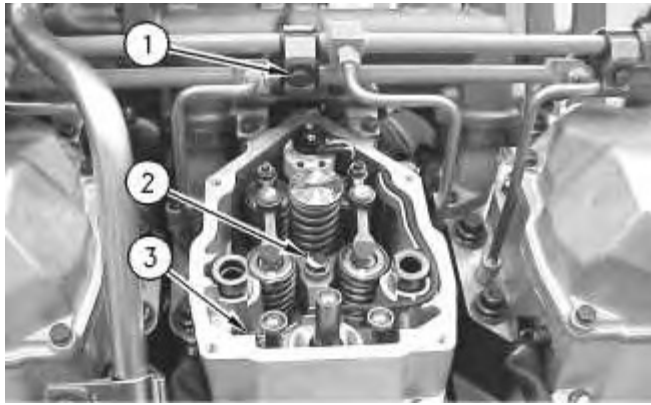

Illustration 1

g00903832

1. Remove bolt (1) and the clamp.
2. Remove bolt (2) and the clamp.
3. Disconnect harness assembly (3).

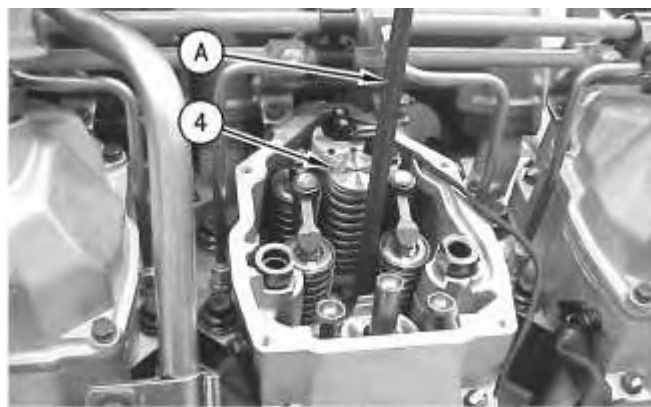

Illustration 2

g00903932

4. Use Tooling (A) to remove electronic unit injector (4).
  5. Remove fuel / fluids from the cylinder. **WARNING!** Turning over (cranking) an engine with an injector removed could result in personal injury or death from fluids escaping at high velocity.
-

Product: TRUCK

Model: 789D TRUCK SPD

Configuration: 789D Off-Highway Truck SPD00001-UP (MACHINE) POWERED BY 3516 Engine

## Disassembly and Assembly

### 3500 and 3500B High Displacement Engines for Caterpillar Built Machines

Media Number -SEN1126-33

Publication Date -01/07/2015

Date Updated -14/09/2018

i02415334

## Electronic Unit Injector - Install

SMCS - 1290-012

### Installation Procedure

Table 1

Required Tools			
Tool	Part Number	Part Description	Qty
B	9U-6862	Tapered Brush	1
C	4C-5027	Tap Wrench	1
D	4C-6774	Vacuum Gun Kit	1
E	1P-0808	Multipurpose Grease	1
F	1U-5512 or 8T-7765	Abrasive Material or Surface Reconditioning Pad	1

---

#### NOTICE

**Keep all parts clean from contaminants.**

**Contaminants may cause rapid wear and shortened component life.**

---

---

#### NOTICE

**Remove all carbon deposits from the angled surface at the bottom of the cylinder head bore for the fuel injection pump. Failure to clean this area may prevent the fuel injection pump from seating properly. This could result in failure of the fuel injection pump due to leakage of exhaust gas into the fuel passage.**

---

1. It is important to clean the cylinder head bore for the electronic unit injector before you install the electronic unit injector. Use the following procedure to clean the bore.

**Note:** A fine grade of Scotch Brite material is recommended for cleaning the cylinder head bore for the electronic unit injector. The product is available as Tooling (F).

- a. Place a 38 mm (1.5 inch) square piece of Scotch Brite material on the end of Tooling (B).

**Note:** It should not be necessary to use a power tool to clean the cylinder head bore for the electronic unit injector.

---

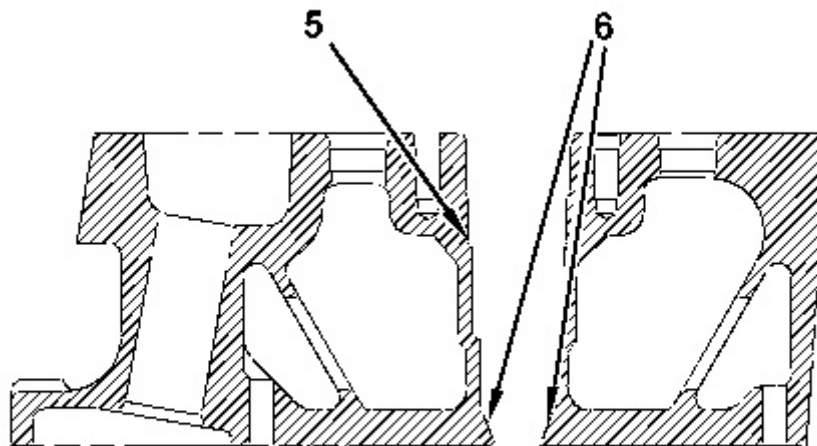

Illustration 1

g01051051

- b. Hold the brush with Tooling (C). Insert the brush into bore (5). Rotate the Scotch Brite material against the lower surface of bore (6). Continue cleaning until the surface is smooth and shiny.

**Note:** Tooling (D) is recommended for cleaning loose particles from the bore. The vacuum is operated with pressurized air.

- c. Remove all loose particles from the bore.

2. Remove any fuel / fluid that may have accumulated before installing the injector.
-

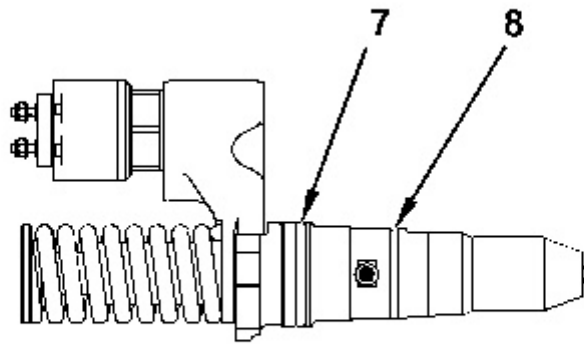

Illustration 2

g01051052

3. Inspect O-ring seals (7) and (8) for good condition. Obtain new O-ring seals, if necessary. Coat the O-ring seals and coat the cylinder head bore for the electronic unit injector with Tooling (E).
4. Press the electronic unit injector into the bore of the cylinder head. Do not strike the electronic unit injector. Center the solenoid between the valve springs.

**Note:** Adjust the height of the electronic unit injector according to the Service Manual, "Specifications".

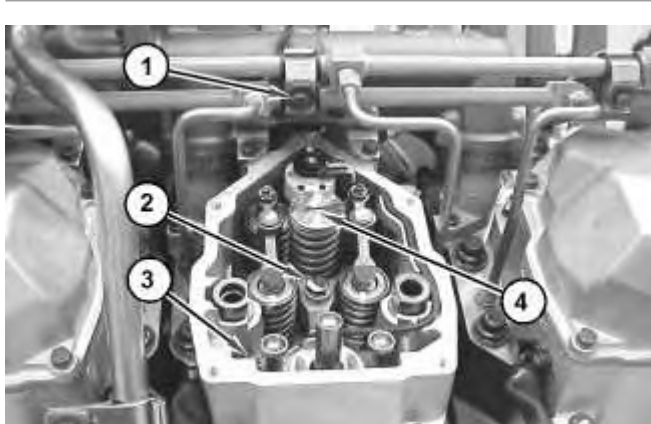

Illustration 3

g01052571

5. To seat electronic unit injector (4) into the bore, install the clamp with bolt (2) and the washer. Tighten the bolt to a torque of  $65 \pm 7$  N·m ( $48 \pm 5$  lb ft).
6. Connect harness assembly (3) to the connector. Tighten the terminal nuts to a torque of  $1.70 \pm 0.25$  N·m ( $15 \pm 2$  lb in).
7. Press the harness assembly into the groove in the valve cover base.

8. Install bolt (1) and the clamp.

**End By:**

- a. Install the rocker shaft assembly and the pushrods. Refer to Disassembly and Assembly, "Rocker Shaft and Push Rods - Install".
-

Product: TRUCK

Model: 789D TRUCK SPD

Configuration: 789D Off-Highway Truck SPD00001-UP (MACHINE) POWERED BY 3516 Engine

## Disassembly and Assembly

### 3500 and 3500B High Displacement Engines for Caterpillar Built Machines

Media Number -SEN1126-33

Publication Date -01/07/2015

Date Updated -14/09/2018

i02414981

## Cylinder Head - Remove

SMCS - 1100-011

### Removal Procedure

Table 1

Required Tools			
Tool	Part Number	Part Description	Qty
A	138-7573	Link Bracket	2

#### Start By:

- Remove the valve cover base. Refer to Disassembly and Assembly, "Valve Cover Base - Remove and Install".

---

#### NOTICE

**Keep all parts clean from contaminants.**

**Contaminants may cause rapid wear and shortened component life.**

---

---

#### NOTICE

**Do not allow dirt to enter the fuel system. Thoroughly clean the area around a fuel system component that will be disconnected. Fit a suitable cover over disconnected fuel system component.**

---

---

## NOTICE

Care must be taken to ensure that fluids are contained during performance of inspection, maintenance, testing, adjusting, and repair of the product. Be prepared to collect the fluid with suitable containers before opening any compartment or disassembling any component containing fluids.

Refer to Special Publication, NENG2500, "Dealer Service Tool Catalog" for tools and supplies suitable to collect and contain fluids on Cat products.

Dispose of all fluids according to local regulations and mandates.

---

1. Drain the coolant from the cooling system. Refer to Operation and Maintenance Manual, "Cooling System Coolant - Change".

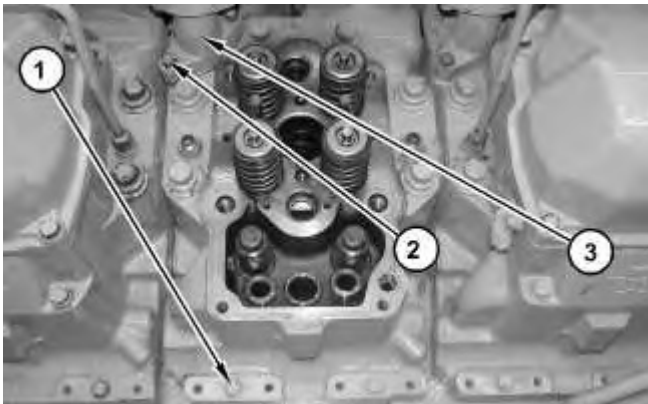

Illustration 1

g01053854

2. Remove bolts (1) and (2). Remove tube (3).

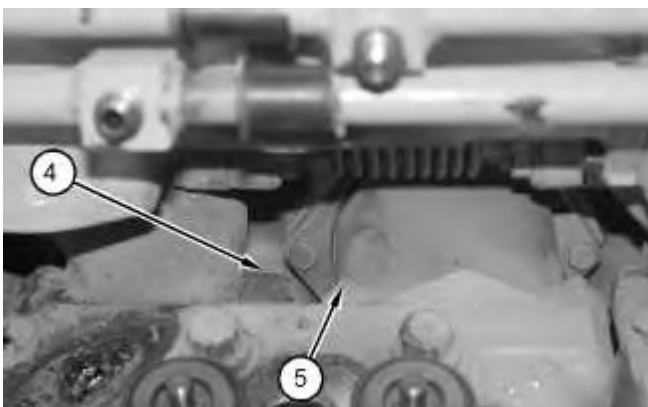

Illustration 2

g01053859



3. Remove four bolts (4) (not shown) from exhaust tube assembly and remove four bolts (5) (not shown) from inlet tube assembly.
- 

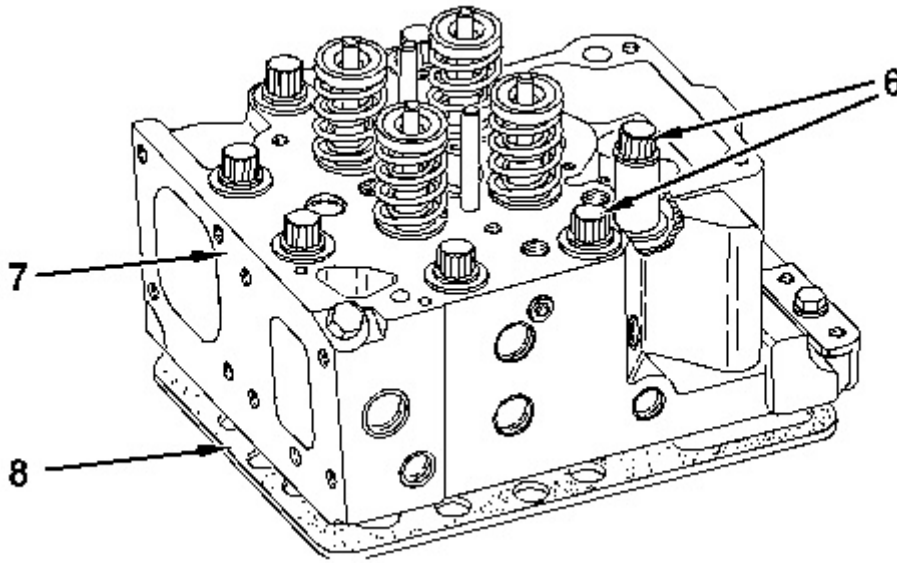

Illustration 3

g01053860

4. Remove bolts (6). Use a suitable lifting device and Tooling (A) in order to remove cylinder head assembly (7). The weight of cylinder head assembly (7) is approximately 47 kg (104 lb). Remove gasket (8).
- 

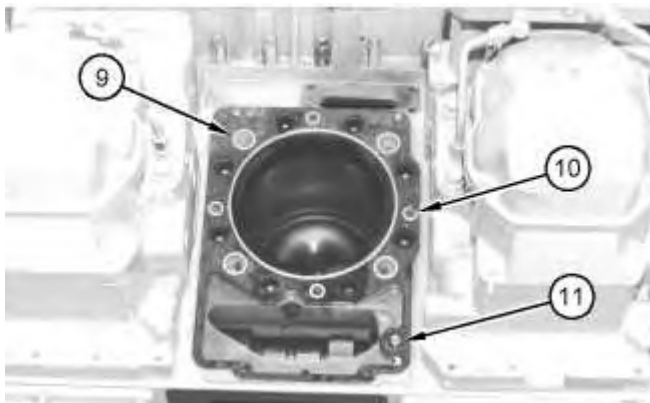

Illustration 4

g01053975

5. Remove seals (9) and (10), and O-ring seal (11) from the spacer plate.
-

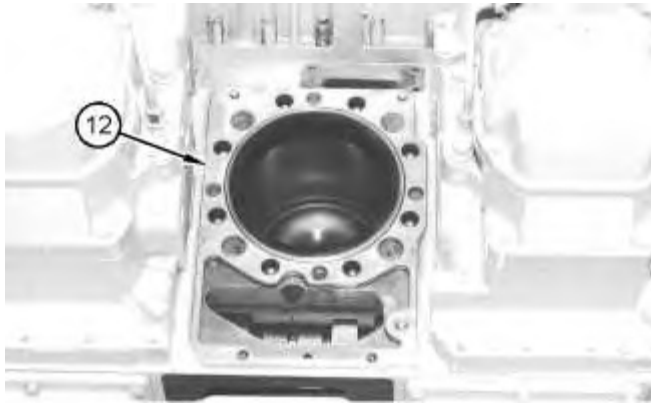

Illustration 5

g01053977

6. Remove spacer plate (12) from the dowels in the cylinder block.



Illustration 6

g01053978

7. Remove gasket (13) from the dowels.

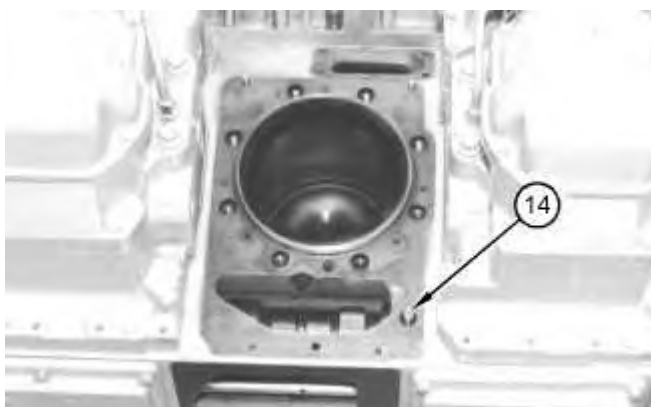

Illustration 7

g01053983

8. Remove the O-ring seal from dowel (14).
-

Product: TRUCK

Model: 789D TRUCK SPD

Configuration: 789D Off-Highway Truck SPD00001-UP (MACHINE) POWERED BY 3516 Engine

## Disassembly and Assembly

### 3500 and 3500B High Displacement Engines for Caterpillar Built Machines

Media Number -SEN1126-33

Publication Date -01/07/2015

Date Updated -14/09/2018

i02048542

## Cylinder Head - Disassemble

SMCS - 1100-015

## Disassembly Procedure

### Start By:

- a. Remove the cylinder head. Refer to Disassembly and Assembly, "Cylinder Head - Remove".

## Inlet and Exhaust Valves

Table 1

Required Tools			
Tool	Part Number	Part Description	Qty
A	5S-1330	Valve Spring Compressor	1
B	8S-2263	Spring Tester	1

---

### NOTICE

**Keep all parts clean from contaminants.**

**Contaminants may cause rapid wear and shortened component life.**

---

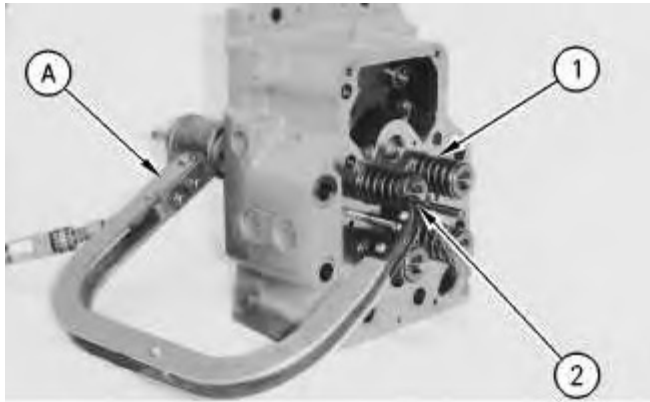

---

Illustration 1

g00905560

## **WARNING**

**Personal injury can result from being struck by parts propelled by a released spring force.**

**Make sure to wear all necessary protective equipment.**

**Follow the recommended procedure and use all recommended tooling to release the spring force.**

---

---

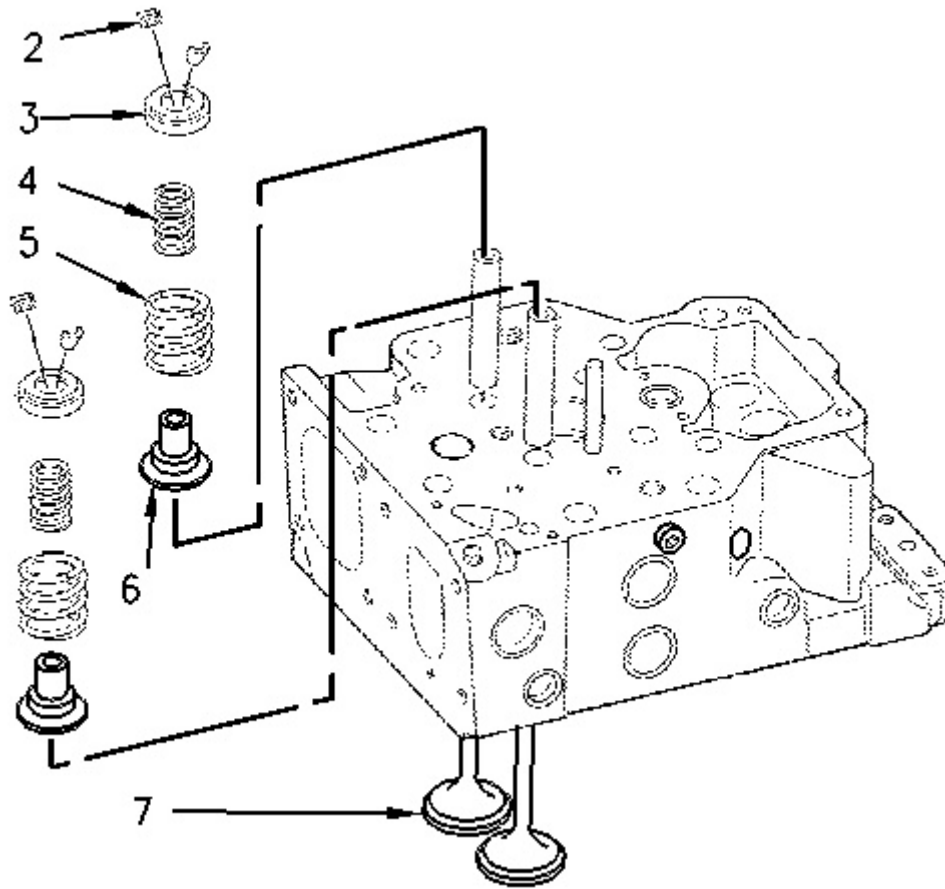

Illustration 2

g00618922

1. Use Tooling (A) to compress valve spring (1).
2. Remove retainer lock (2).
3. Release the tension on Tooling (A). Remove Tooling (A).
4. Remove valve rotator (3), outer spring (5), inner spring (4), and seal (6).

**Note:** If the valves will be reused, mark the valves for identification upon assembly.

5. Remove valve (7) from the cylinder head.
6. Use Tooling (B) to measure the force of the valve springs. Refer to Specifications for the correct spring force.
7. Repeat Steps 1 through 6 for the remaining valves.

## Bridge Dowels

Table 2

Required Tools			
Tool	Part Number	Part Description	Qty
C	5P-0944	Dowel Puller Group	1

---

**NOTICE**

**Keep all parts clean from contaminants.**

**Contaminants may cause rapid wear and shortened component life.**

---

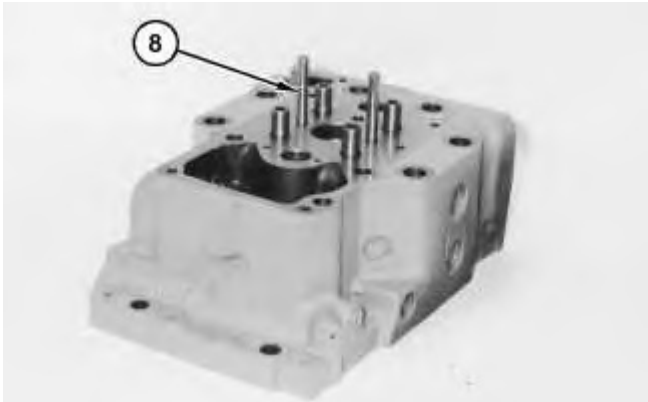

Illustration 3

g01051069

1. If the bridge dowels will be replaced, use Tooling (C) to remove bridge dowel (8) from the cylinder head.

### Inlet and Exhaust Valve Seat Inserts

Table 3

Required Tools			
Tool	Part Number	Part Description	Qty
D	166-7441	Valve Seat Extractor Tool	1

---

**NOTICE**

**Keep all parts clean from contaminants.**

**Contaminants may cause rapid wear and shortened component life.**

---

1. Use Tooling (D) to remove the valve seat inserts from the cylinder head.
2. Thoroughly clean valve seat bores in the cylinder head.

## Inlet and Exhaust Valve Guides

Table 4

Required Tools			
Tool	Part Number	Part Description	Qty
E	7M-3975	Valve Guide Driver	1
	5P-1729	Valve Guide Bushing	1

---

### NOTICE

**Keep all parts clean from contaminants.**

**Contaminants may cause rapid wear and shortened component life.**

---

1. Use Tooling (E) and a hammer to remove the valve guides from the cylinder head.

## Valve Lifters

---

### NOTICE

**Keep all parts clean from contaminants.**

**Contaminants may cause rapid wear and shortened component life.**

---

**Note:** The valve lifters may also be removed with the cylinder head on the engine. Remove the camshaft and use the following steps in order to remove the valve lifters with the cylinder head on the engine.

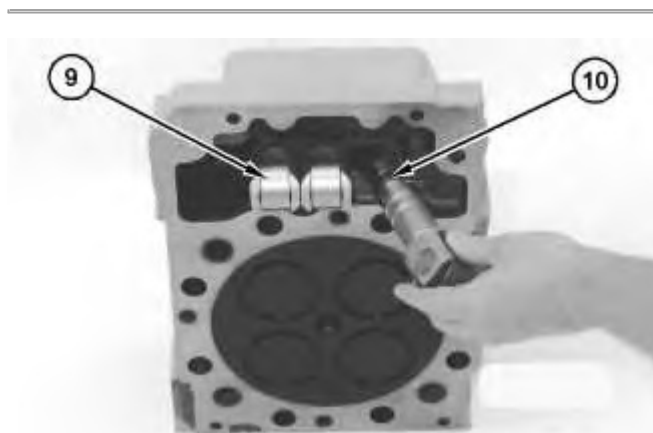
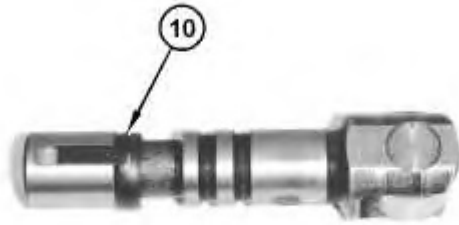

Illustration 4

g01051072



---

Illustration 5

g01051073

 **WARNING**

**Personal injury can result from being struck by parts propelled by a released spring force.**

**Make sure to wear all necessary protective equipment.**

**Follow the recommended procedure and use all recommended tooling to release the spring force.**

- 
1. Pull valve lifter (9) out of the cylinder head.
  2. Remove guide spring (10) from the valve lifter.
-



Product: TRUCK

Model: 789D TRUCK SPD

Configuration: 789D Off-Highway Truck SPD00001-UP (MACHINE) POWERED BY 3516 Engine

## Disassembly and Assembly

### 3500 and 3500B High Displacement Engines for Caterpillar Built Machines

Media Number -SEN1126-33

Publication Date -01/07/2015

Date Updated -14/09/2018

i06795257

## Cylinder Head - Assemble

SMCS - 1100-016

## Assembly Procedure

### Valve Lifters

---

#### NOTICE

**Keep all parts clean from contaminants.**

**Contaminants may cause rapid wear and shortened component life.**

---



---

Illustration 1

g01051073

---

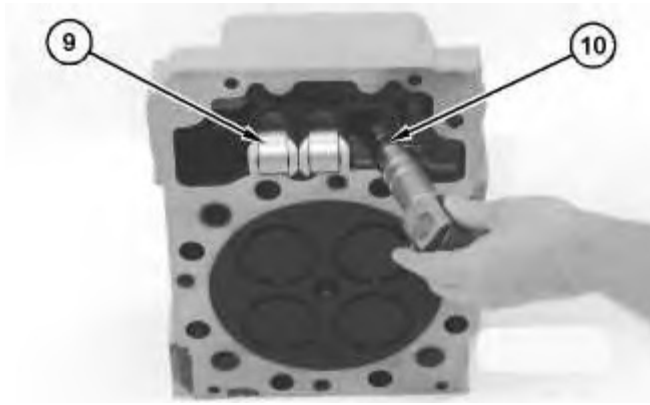

Illustration 2

g01051072

**! WARNING**

**Improper assembly of parts that are spring loaded can cause bodily injury.**

**To prevent possible injury, follow the established assembly procedure and wear protective equipment.**

**Note:** Install the lifter assembly into the cylinder head. Ensure that the word "LEFT" stamped on end of the bronze pin is always oriented to the LEFT as viewed from the side of the engine regardless of left side or right side bank. Immerse the lifter assembly in engine oil before assembled in the cylinder head lifter bore.

1. Install new guide spring (10) for valve lifter (9).
2. Place valve lifter (9) in a container of clean engine oil prior to installation.
3. Install valve lifter (9) into the cylinder head.

**Note:** Refer to Specifications, "Valve Mechanism".

### Inlet and Exhaust Valve Guides

Table 1

Required Tools			
Tool	Part Number	Part Description	Qty
E	7M-3975	Valve Guide Driver	1
	5P-1729	Valve Guide Bushing	1

**NOTICE**

**Keep all parts clean from contaminants.**

**Contaminants may cause rapid wear and shortened component life.**

---

**Note:** Use new valve guides for assembly.

1. Coat the outside of the valve guides with clean engine oil prior to installation.
2. Use Tooling (E) and a suitable press to install the valve guides. The valve guide must extend  $26.0 \pm 0.50$  mm ( $1.02 \pm 0.020$  inch) above the surface of the cylinder head.

## Inlet and Exhaust Valve Seat Inserts

Table 2

Required Tools			
Tool	Part Number	Part Description	Qty
F	1P-0510	Driver Gp	1

---

### NOTICE

**Keep all parts clean from contaminants.**

**Contaminants may cause rapid wear and shortened component life.**

---

**Note:** Use new inserts for assembly.

1. Lower the temperature of the valve seat inserts. Install the valve seat inserts with Tooling (F).

## Bridge Dowels

Table 3

Required Tools			
Tool	Part Number	Part Description	Qty
G	6V-4009	Dowel Driver	1

---

### NOTICE

**Keep all parts clean from contaminants.**

**Contaminants may cause rapid wear and shortened component life.**

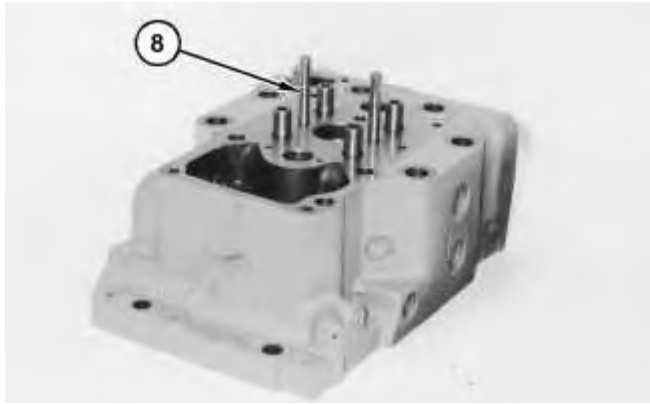

Illustration 3

g01051069

**Note:** Use new dowels for assembly. Refer to Service Magazine, SEPD1825, "New Cylinder Head Groups and Valve Mechanisms" for the correct procedure.

1. Use Tooling (G) with a hammer to install bridge dowels (8). The bridge dowels must extend  $66.5 \pm 0.50$  mm ( $2.62 \pm 0.020$  inch) above the surface of the cylinder head.

## Inlet and Exhaust Valves

Table 4

Required Tools			
Tool	Part Number	Part Description	Qty
A	5S-1330	Valve Spring Compressor	1

---

### NOTICE

**Keep all parts clean from contaminants.**

**Contaminants may cause rapid wear and shortened component life.**

---

---

Thank you so much for reading.  
Please click the “Buy Now!”  
button below to download the  
complete manual.



After you pay.

You can download the most  
perfect and complete manual in  
the world immediately.

Our support email:

[ebooklibonline@outlook.com](mailto:ebooklibonline@outlook.com)