

Product: TRUCK

Model: 793B TRUCK 1HL

Configuration: 793B Off-Highway Truck 1HL00001-UP (MACHINE) POWERED BY 3516 Engine

Disassembly and Assembly 793B OFF-HIGHWAY TRUCK POWER TRAIN

Media Number -SEN5691-02

Publication Date -01/03/2005

Date Updated -17/03/2016

SEN56910018

Transmission Hydraulic Control Valves

SMCS - 3167-010; 3167-015; 3167-016

Remove & Install Transmission Hydraulic Control Valves

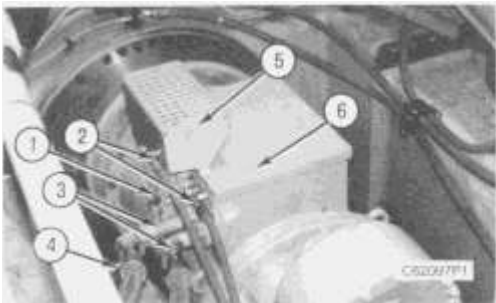

1. Remove guard (5) and the gasket and cover (6) from the top of the transmission.
2. Disconnect the lines from fittings (2) and flanges (3).
3. Disconnect wire harness (4) from the base of solenoid valve (1).

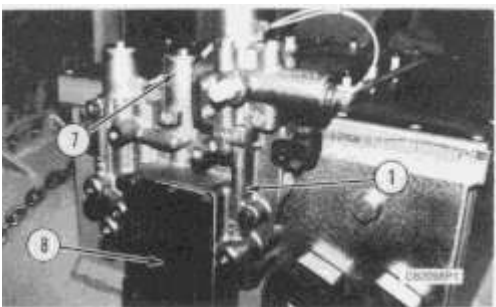

4. Mark for identification purposes and disconnect the wires from three solenoids (7).
5. Remove cover (8) from solenoid valve (1).

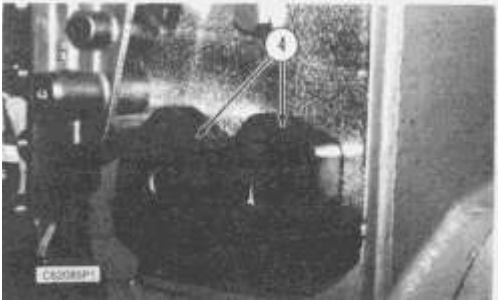
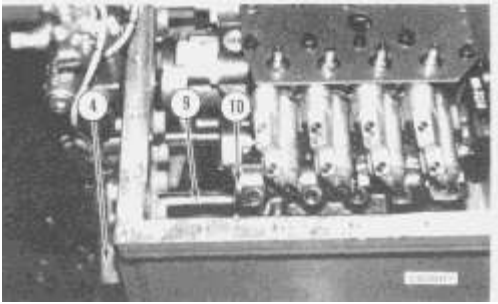

6. Remove the bolt and plate (10) that hold tubes (9) in position in the transmission hydraulic control valve. Remove tubes (9) and flanges (4) from the transmission hydraulic control valve.
7. Separate flanges (4) from tubes (9). Check the condition of the O-ring seals on each end of tubes (9). Use new parts for replacement if the O-ring seals are worn or damaged.

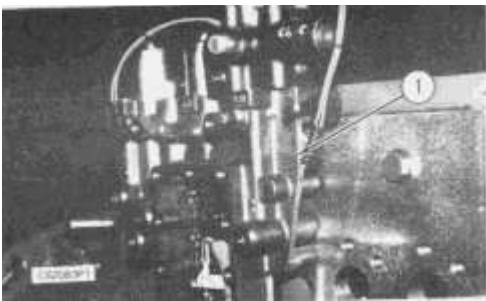

8. Remove the bolts and solenoid valve (1) from the transmission case.

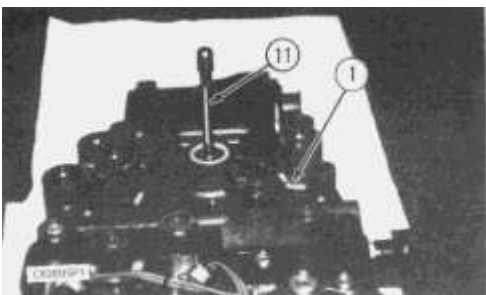

9. Remove coupling assembly (11) from solenoid valve (1).
10. Check the condition of the O-ring seals on the back of valve (1). Use new parts for replacement if the O-ring seals are worn or damaged.

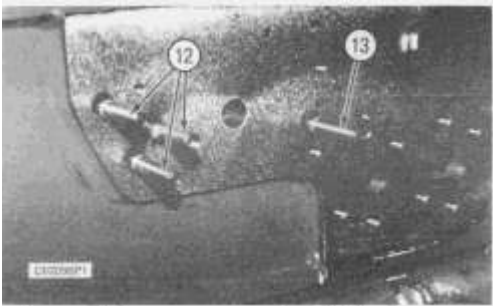

11. Remove three tubes (12) and one tube (13) from the transmission hydraulic control valve and case. Check the condition of the O-ring seals on tubes (12) and (13). Use new parts for replacement if the O-ring seals are worn or damaged.

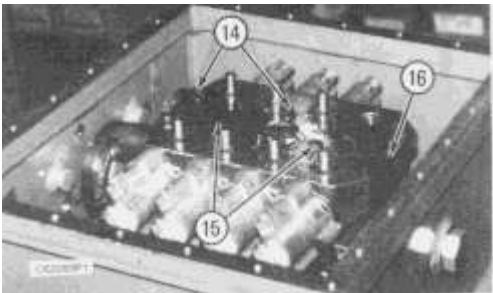

12. Remove two bolts (14) and two bolts (15). For assembly purposes, the torque for bolts (14) and (15) is $48 \pm 4 \text{ N}\cdot\text{m}$ ($35 \pm 3 \text{ lb ft}$).

13. Attach a hoist to transmission hydraulic control valve (16), and remove it from the transmission. The weight of the transmission hydraulic control valve is **61 kg (135 lb)**.

14. Install the transmission control valve in the reverse order of removal.

Disassemble Transmission Hydraulic Control Valves

Tools Needed		A	B
1P1853	Retaining Ring Pliers	1	
1P0510	Driver Group		1

Start By:

a. remove transmission hydraulic control valves.

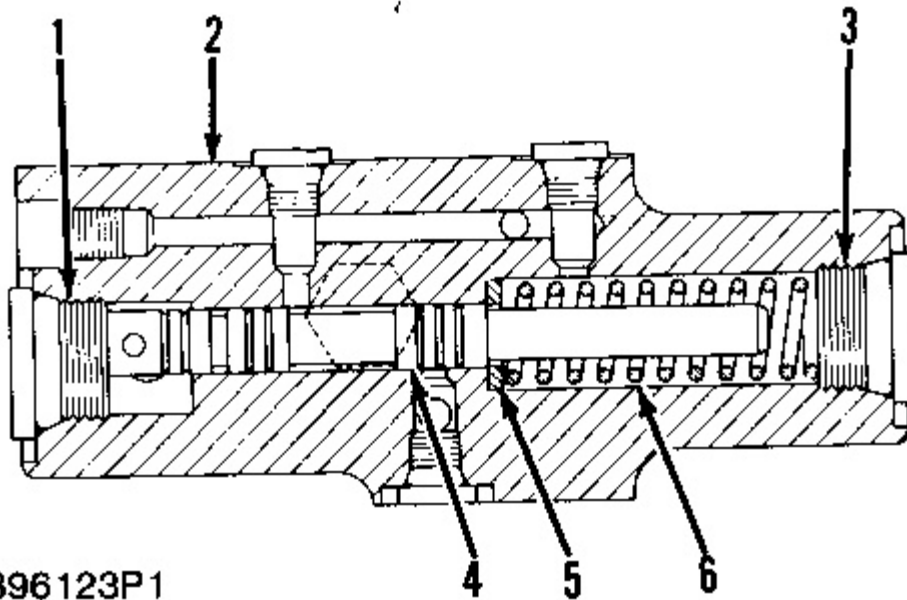

B96123P1

1. Remove plugs (1) and (3) from relay valve body (2).
2. Remove the O-ring seals from the plugs if necessary.
3. Remove spool (4) and spring (6) from body (2).
4. Remove washer (5) from body (2).
5. Remove the remainder of the plugs from body (2) if necessary.

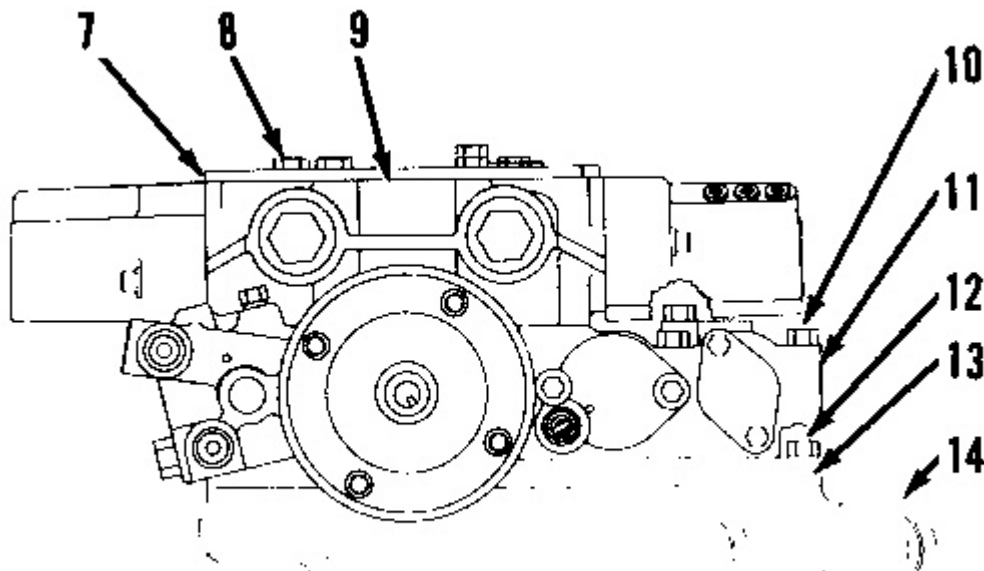

B96124P1

6. Remove bolts (8), and remove cover (7) from pressure control valve group (9).
7. Remove pressure control valve group (9) from selector and pressure valve group (11).
8. Remove bolts (10) and selector and pressure valve group (11).

9. Remove bolts (12) and plate (13) from manifold (14).

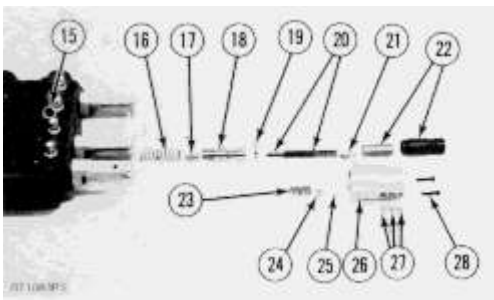
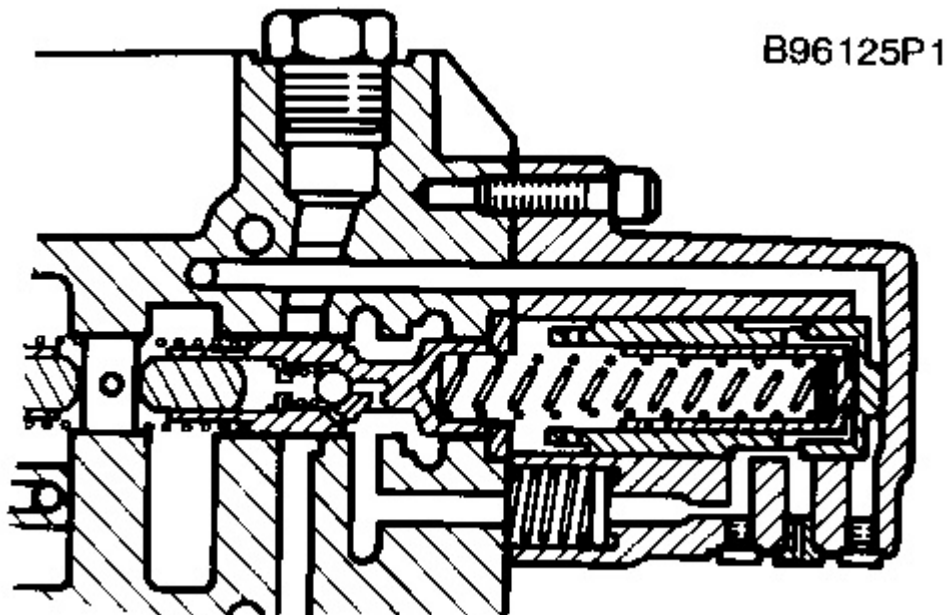

Typical Example

NOTE: The pressure control valve for each clutch is identified on the pressure control valve body by a letter at location (15) on the valve body. The letter is also stamped on body (26).

NOTICE

Do not at any time mix the components between valve groups during disassembly or assembly.

NOTE: Valve group (A) is for clutch No. 2. Valve group (B) is for clutch No. 1. Valve group (C) is for clutch No. 3. Valve group (D) is for the lockup/two stage relief valve. Valve group (E) is for clutch No. 4. Valve group (F) is for clutch No. 5. Valve group (G) is for clutch No. 6.

10. Use the following procedure to disassemble the valve groups.

a. Remove two screws (28) and body (26) from the valve body.

NOTE: On valve groups (B) and (F) there is a pin inside springs (20).

b. Remove two springs (20), shims (21) and two pistons (22) from body (26).

NOTE: On valve groups (A) and (F), the center plug of plugs (27) has a screen on it. On valve group (D) and (G), there is no center plug.

c. Remove spring (23), orifice (24), O-ring seal (25) and three plugs (27) from body (26).

d. Remove stop (19), spool (18) and spring (16) from the valve body.

e. Remove slug (17) from spool (18).

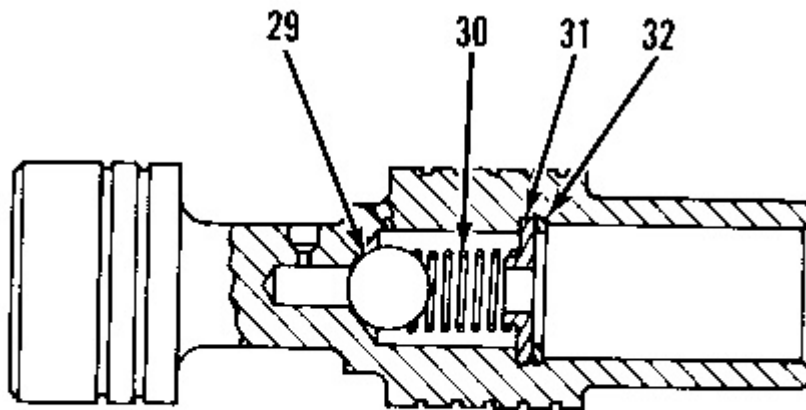

B71086P5

11. Use the following procedure to disassemble spools (18) from the valve groups.

a. Use tool (A) to remove snap ring (32) from the spool.

b. Remove retainer (31), spring (30) and ball (29) from the spool.

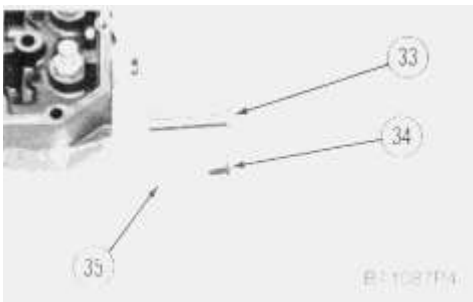

12. Remove bolt (34), washer (35) and piston (33) from the valve body.

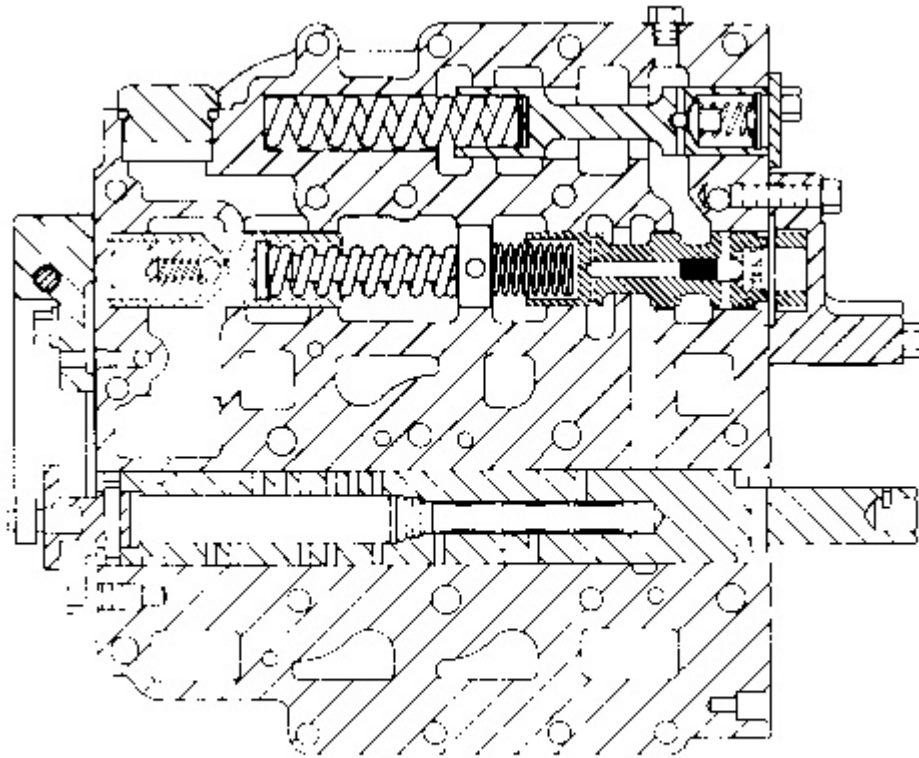

B96126P1

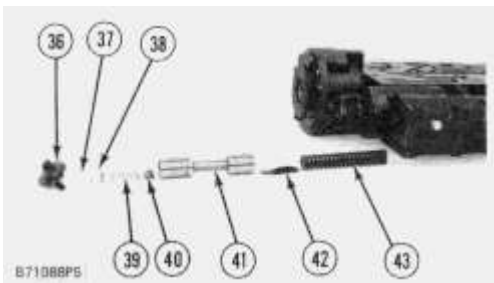

 **WARNING**

There is spring pressure against cover (36). To prevent personal injury, hold cover (36) while the bolts are removed.

13. Remove cover (36), spool (41) and spring (43) from the valve body.
14. Remove spiral ring (37), retainer (38), spring (39) and check valve (40) from spool (41).
15. Remove shims (42) from the end of the spool.

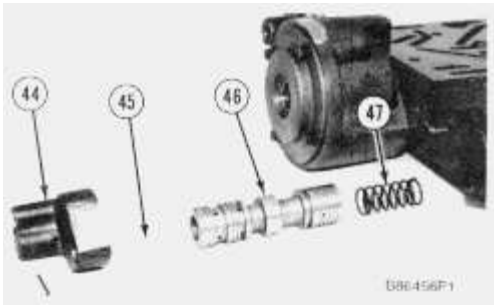

16. Remove cover (44), spool (46) and spring (47) from the valve body.

17. Remove O-ring seal (45) and the pin from cover (44).

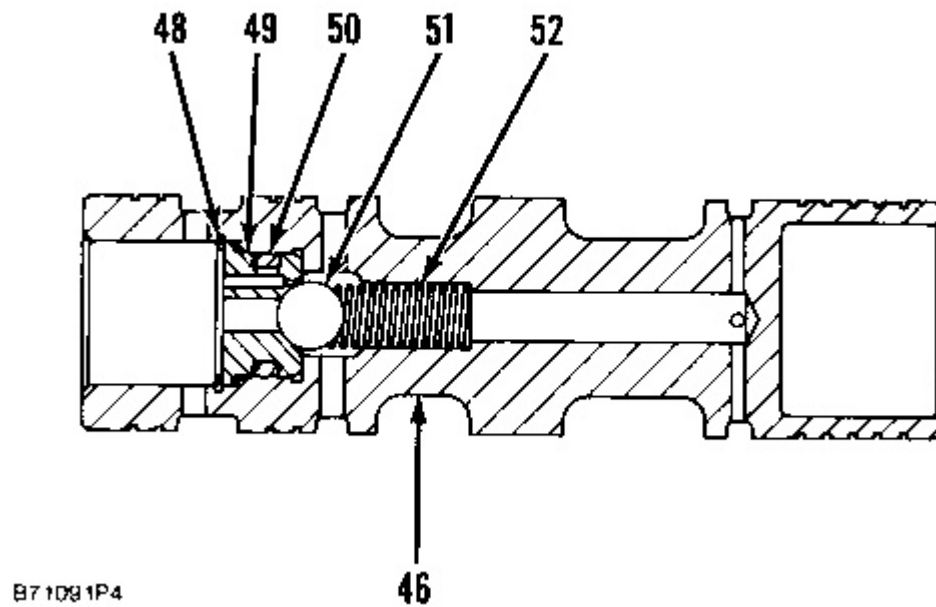

18. Use the following procedure to disassemble spool (46).

a. Use tool (A) to remove snap ring (48) from the spool.

b. Remove seat (49), ball (51) and spring (52).

c. Remove O-ring seal (50) from seat (49).

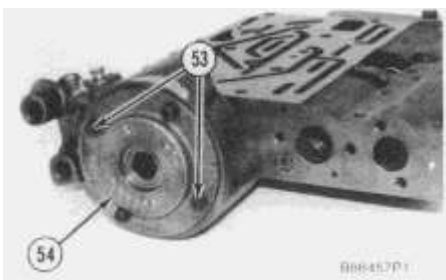

19. Remove two bolts (53) and actuator (54).

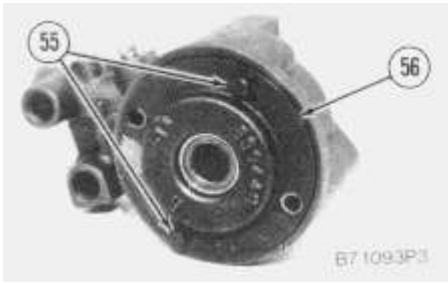

20. Remove two bolts (55) and cover (56).

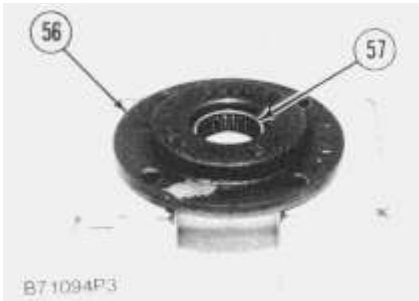

21. Use tooling (B) to remove bearing (57) from cover (56).

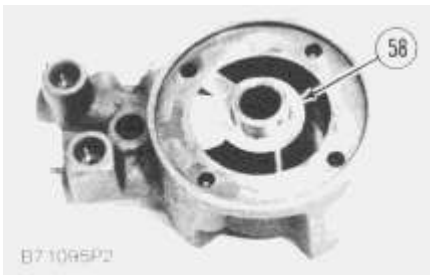

22. Remove rotor (58) from the actuator.

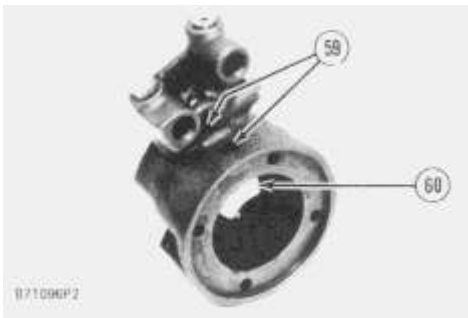

23. Remove two bolts (59) and vane (60).

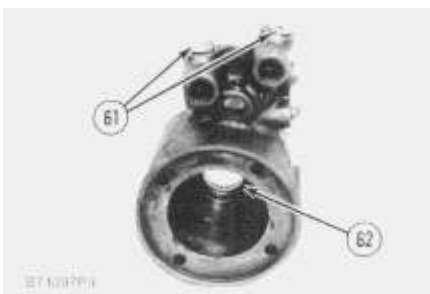

24. Remove two plugs (61) from the actuator. Remove the valve that is under each plug. Remove the O-ring seal from each plug.

25. Use tooling (B) to remove bearing (62) from the actuator.

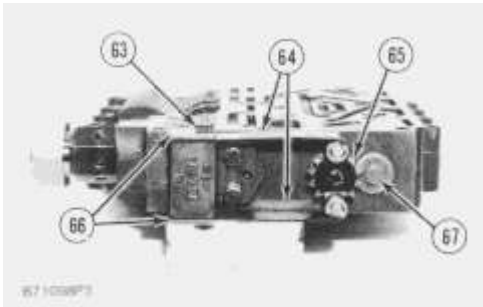

Typical Example

26. Remove two bolts (63). Remove retainers (66) and springs (64).

27. Remove bolt (67), the washer and rotary selector spool (65).

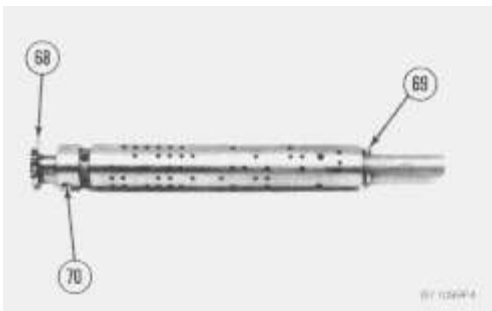

28. Remove pin (70), cam (68) and the screen from the rotary selector spool.

29. Remove pin (69).

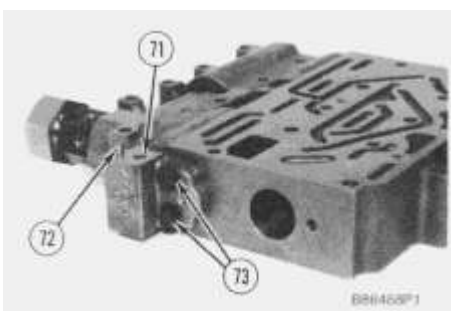

Typical Example



WARNING

Support (71) holds a spring under compression. To prevent personal injury, hold support (71) when bolts (73) are removed.

30. Remove bolts (73) and support (71). Remove two dowels (72) from the support if a replacement is necessary.

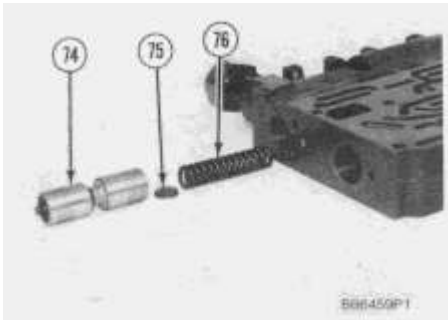

Typical Example

31. Remove spool (74) and spring (76) from the valve body.

32. Remove shims (75) from spool (74).

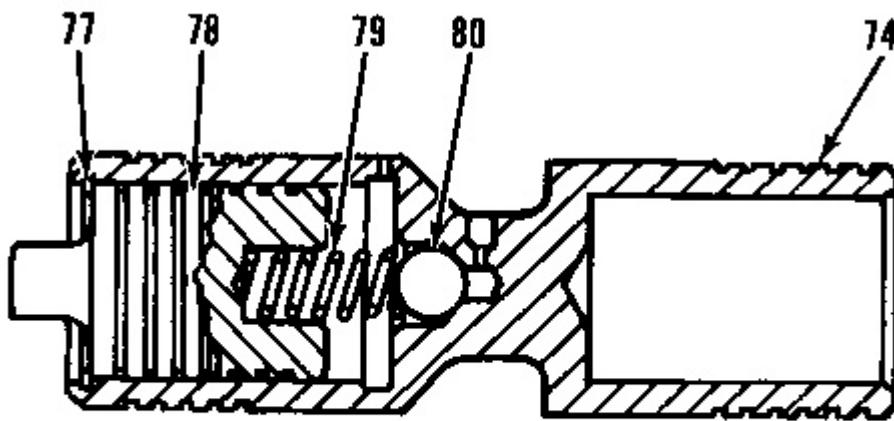

B71089P4

33. Use tool (A) to remove snap ring (77) from spool (74).

34. Remove slug (78), spring (79) and ball (80) from the spool.

Assemble Transmission Hydraulic Control Valves

Tools Needed		A	B
1P1853	Retaining Ring Pliers	1	
1P0510	Driver Group		1

NOTICE

Do not use caustic (corrosive) materials to clean any parts in this valve group. Caustic materials will cause corrosion and damage to parts.

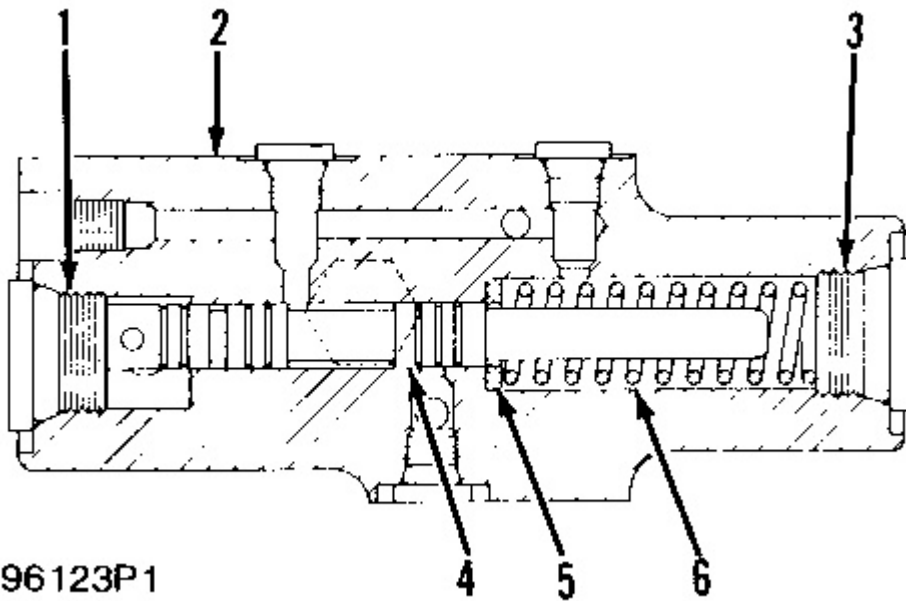

B96123P1

1. Put washer (5), spool (4), and spring (6) in position in relay valve body (2).
2. Put the O-ring seals in position on plugs (1) and (3) and install them in the body to hold the spring and spool.
3. If the rest of the plugs were removed, put the O-ring seals in position on the plugs and install them in relay valve body (2).

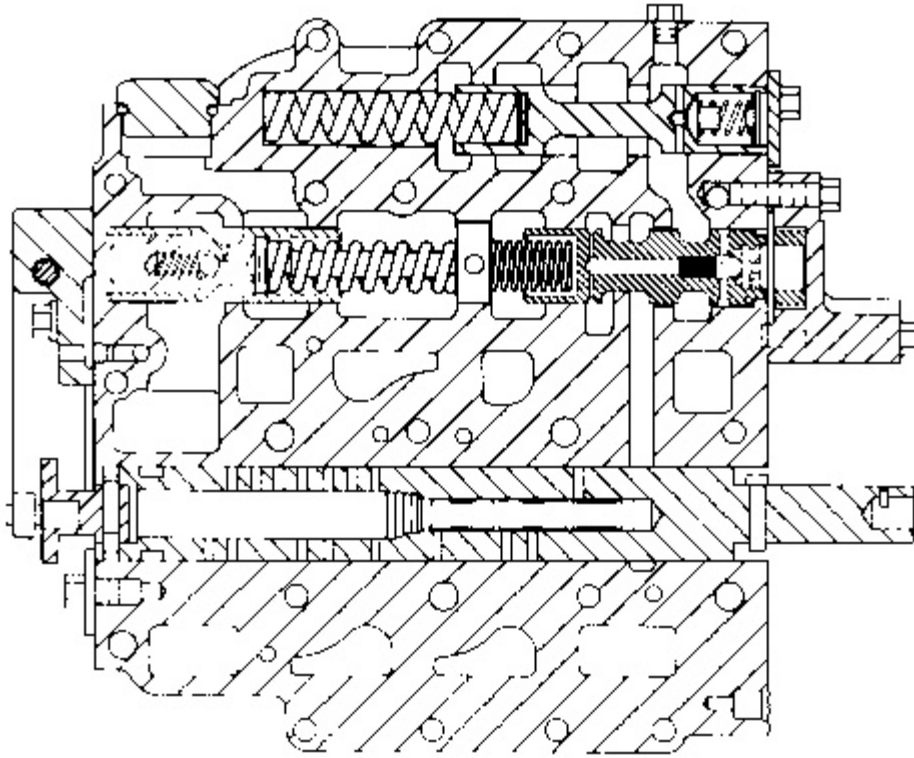

B96126P1

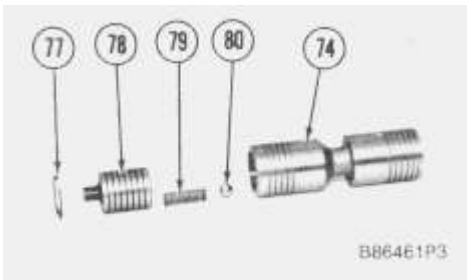

4. Put clean SAE 30 oil on slug (78). Install ball (80), spring (79) and slug (78) in spool (74). Use tool (A) to install snap ring (77).

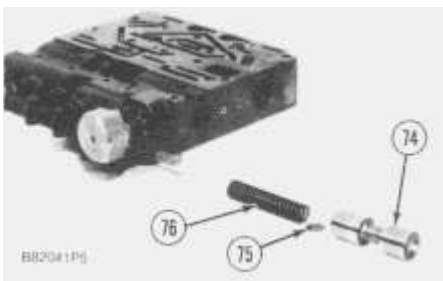

5. Put clean SAE 30 oil on spool (74). Install shims (75) in the end of spool (74).

6. Install spring (76) and spool (74) in the selector valve as shown.

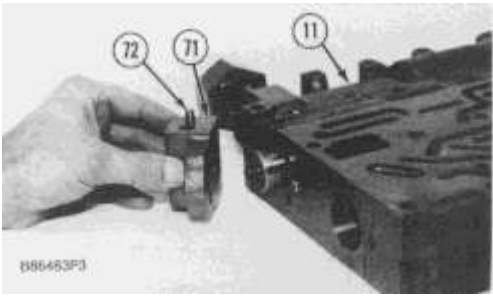

7. Install two dowels (72) on the top and bottom of support (71). Install the dowels so they extend **$6.50 \pm 0.25 \text{ mm}$ ($.256 \pm .010 \text{ in}$)** above the surface.

8. Put support (71) in position on selector valve (11). Install two bolts (73) that hold it in position.

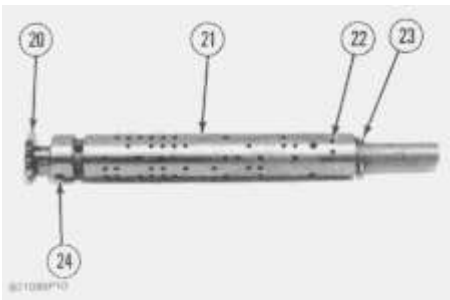

Typical Example

9. Install the screen in rotary selector spool (65). Tighten the screen to a torque of **$6.1 \pm 0.7 \text{ N}\cdot\text{m}$ ($54 \pm 6 \text{ lb in}$)**. Install cam (68) in the rotary selector spool, and install pin (70) that holds the cam in place. Install the pin until it is **$1.0 \pm 0.5 \text{ mm}$ ($.04 \pm .02 \text{ in}$)** below the surface of the rotary selector spool.

10. Install pin (69). Install the pin with the head of the pin up as shown when two holes (81) are in the position shown.

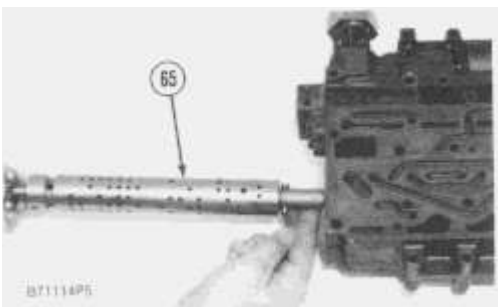

Typical Example

11. Put clean SAE 30 oil on rotary selector spool (65). Install the rotary selector spool in the valve body.

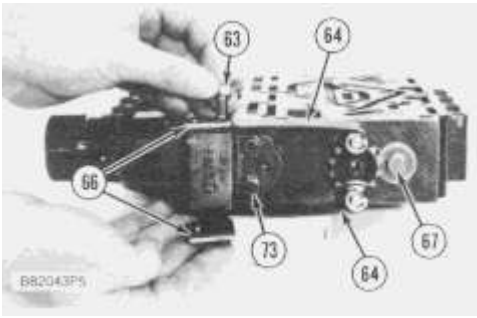

Typical Example

12. Install bolt (67) and the washer that hold the rotary selector spool in position.
13. Install two springs (64), two retainers (66) and bolts (63) that hold the springs in position on the support. Make sure the side of each spring is $4.5 \pm 0.5 \text{ mm}$ ($.18 \pm .02 \text{ in}$) from the side of the selector valve body.
14. Loosen bolts (73) enough to make sure the rollers in springs (64) are in the center of the notches in the cam. Tighten bolts (73).

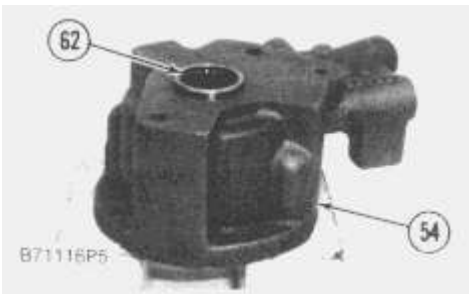

15. Use tooling (B) to install bearing (62) in actuator body (54). Install the bearing so that it extends $3.00 \pm 0.50 \text{ mm}$ ($.118 \pm .020 \text{ in}$) above the surface.

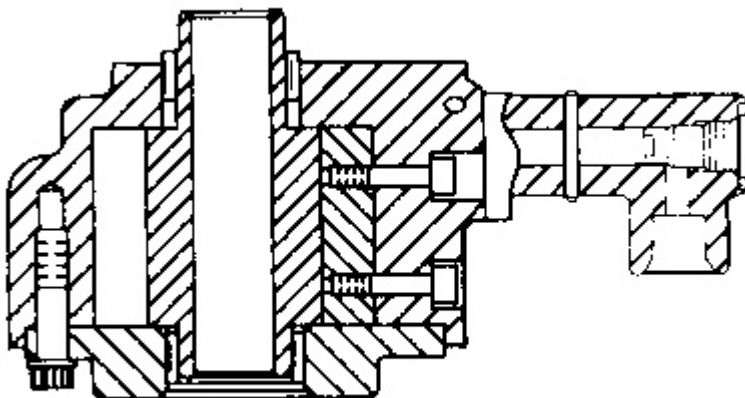

B96128P1

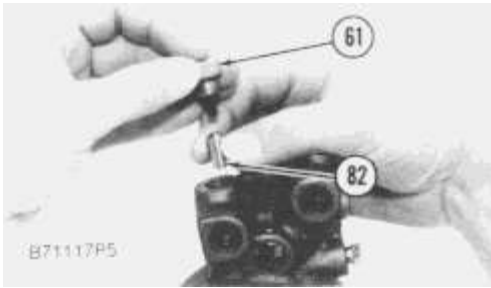

16. Put the O-ring seals in position on plugs (61). Put clean SAE 30 oil on the O-ring seals and on valves (82).

17. Install valves (82) in the actuator body. Make sure the flat end of the valve is installed first. Install plugs (61).

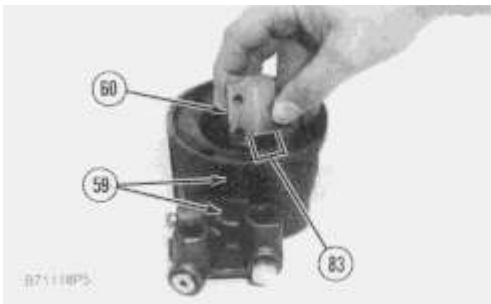

18. Install vane (60) and two bolts (59) in the actuator body. Do not tighten bolts (59) at this time. Make sure notch (83) on the vane is in the position shown.

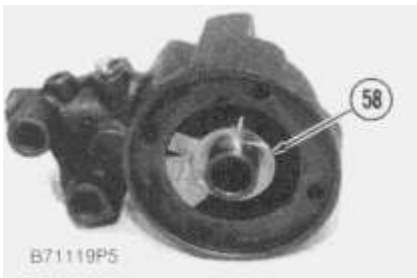

19. Put clean SAE 10 oil on all surfaces of the rotor. Install rotor (58) in the actuator.

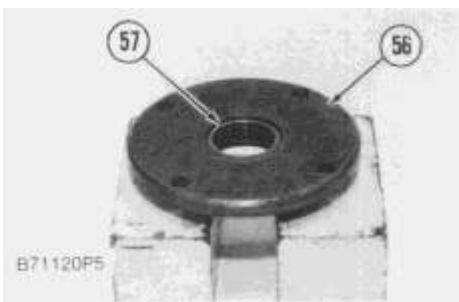

20. Use tooling (B) to install bearing (57) in cover (56). Install the bearing so it is 1.30 ± 0.25 mm ($.051 \pm .010$ in) below the surface.

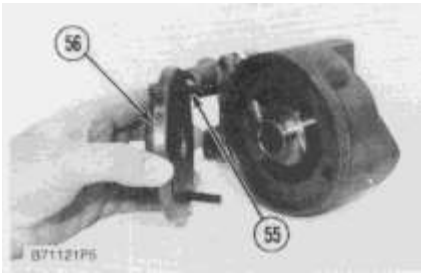

21. Install cover (56) on the actuator body. Install two bolts (55) that hold the cover in position. Tighten bolts (55) to a torque of $30 \pm 4 \text{ N}\cdot\text{m}$ ($22 \pm 3 \text{ lb ft}$).

22. Tighten bolts (59) (see Step 18) to a torque of $15 \pm 3 \text{ N}\cdot\text{m}$ ($11 \pm 2 \text{ lb ft}$).

23. The rotor must turn freely through 300° of rotation.

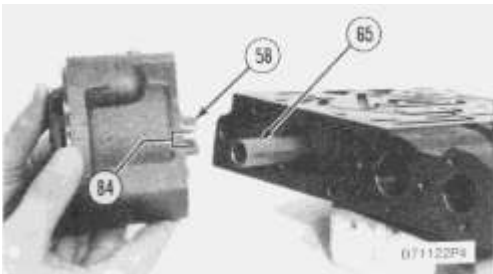

24. Install the actuator on the selector valve body. Make sure the larger groove (slot) (84) in rotor (58) is in alignment with the head on the pin on rotary selector spool (65).

25. Install the two bolts that hold the actuator in position on the selector valve. Tighten the bolts to a torque of $30 \pm 4 \text{ N}\cdot\text{m}$ ($22 \pm 3 \text{ lb ft}$).

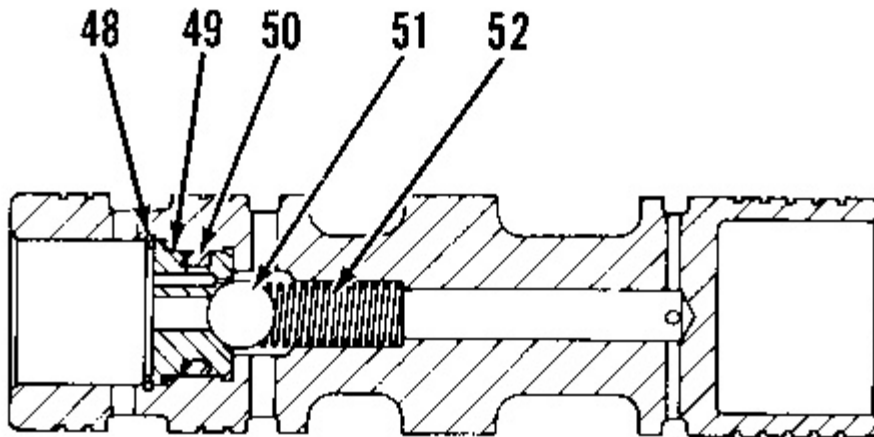

B71091P10

26. Install O-ring seal (50) on seat (49). Put clean SAE 30 oil on the O-ring seal.

27. Install spring (52), ball (51) and seat (49). Use tool (A) to install snap ring (48).

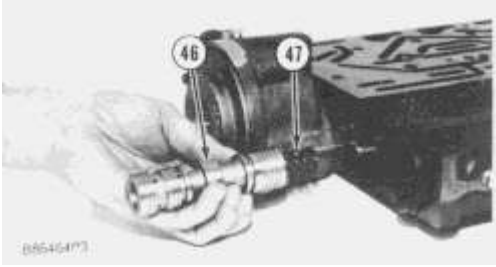

28. Put the shims, spring (47) and neutralizer valve spool (46) in position in the selector valve body. Put the small O-ring seal in position in the selector valve body.

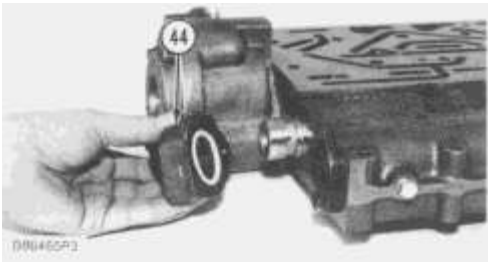

NOTICE

When installing the valve in cover (44), put the end with the ball against the pin.

29. Put the O-ring seal, valve and pin in position in cover (44). Put clean SAE 30 oil on the O-ring seal. Put the cover in position on the selector valve body, and install the bolts that hold it.

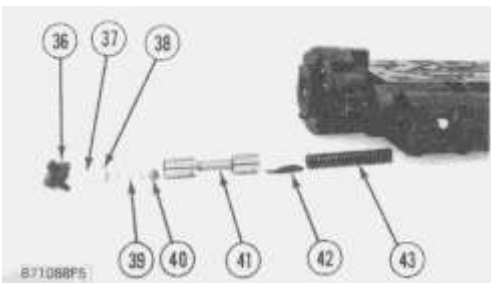

30. Install valve (40), spring (39), retainer (38) and spiral ring (37) in priority reducing valve spool (41).

31. Put shims (42) in position in the end of spool (41). Put clean SAE 30 oil on the outside diameter of spool (41).

32. Install spring (43), spool (41), and cover (36) on the selector control valve.

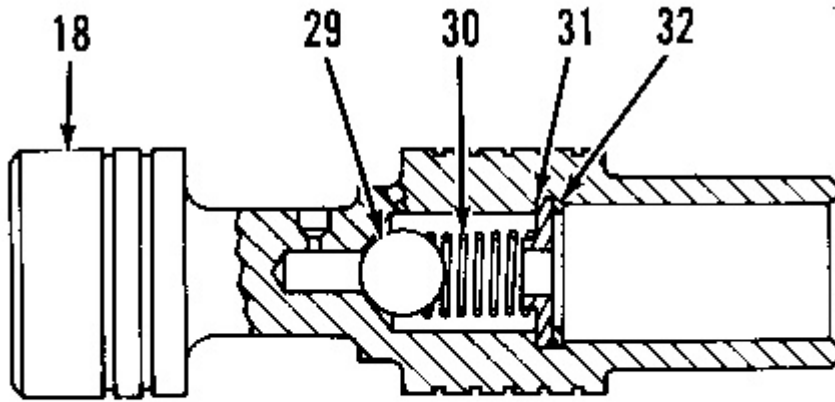

B71086P10

NOTE: Step 33 is the assembly procedure for the spools for valve groups.

33. Install ball (29), spring (30) and retainer (31) in spool (18). Use tool (A) to install snap ring (32) in the end of the spool.

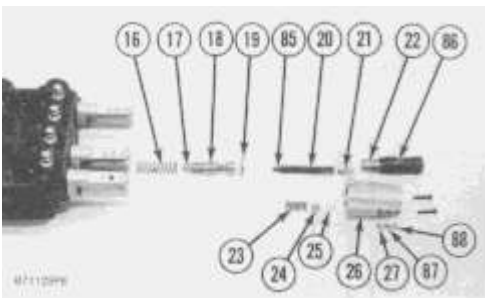

Typical Example

Valve Group	Orifice (24) Thickness	Plug (87) Color	Inner Spring (85) Color	Outer Spring (20) Color
A	4.58 mm .180 in	Yellow	Light Blue	Green
B	2.54 mm .100 in	Green	Blue	Yellow
C	2.54 mm .100 in	Red	Light Blue	Green
D	None	None	Yellow	Blue
E	2.54 mm .100 in	Green	Orange	Green
F	6.60 mm .260 in	Yellow	Yellow	Green
G	6.60 mm .260 in	None	Green	Green
H	None	None	None	None

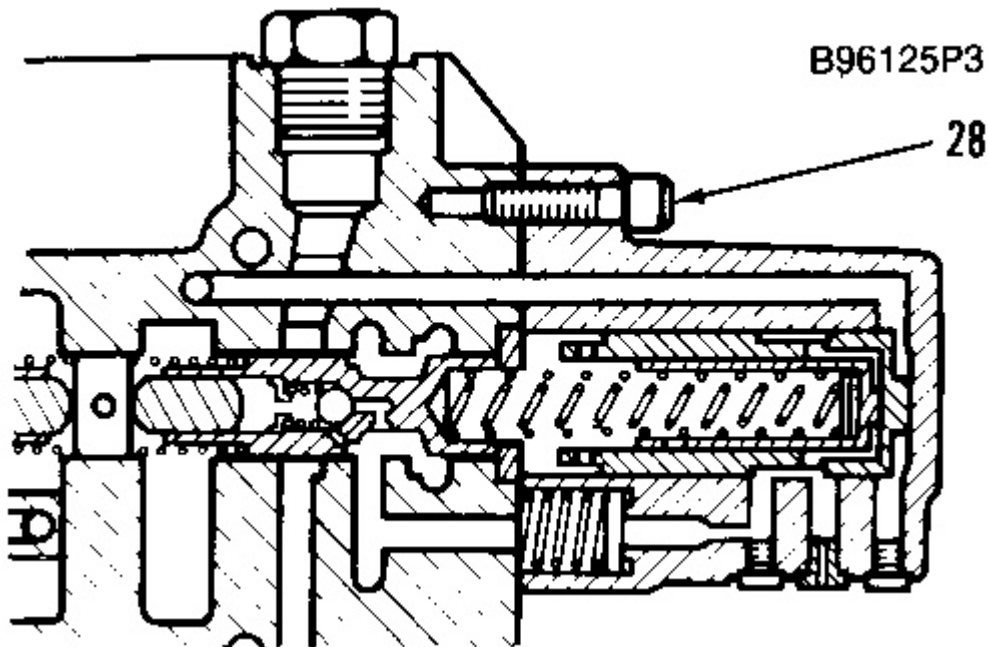

NOTE: The pressure control valve for each clutch is identified on the pressure control valve body by a letter. There is a corresponding letter on each of bodies (26).

NOTICE

Do not at any time mix the components between valve groups during disassembly or assembly.

NOTE: Valve Group A is for clutch No. 2. Valve group B is for clutch No. 1. Valve group C is for clutch No. 3. Valve group D is for the lockup/two stage relief valve. Valve group E is for clutch No. 4. Valve group F is for clutch No. 5. Valve group G is for clutch No. 6.

34. Use the following procedure to assembly the valve groups.

a. Put clean SAE 30 oil on all the surfaces of spool (18) and slug (17). Install slug (17) in the spool as shown.

b. Install spring (16), spool (18) and stop (19) in the pressure control valve.

NOTE: There is no plug (87) in valve group (D) or (G).

c. Make sure the O-ring seals are in position on plugs (27), (87) and (88). Install the plugs in the body.

d. Put clean SAE 30 oil on the O-ring seal (25). Install O-ring seal (25), orifice (24) and spring (23) in body (26).

e. Put clean SAE 30 oil on all the surfaces of pistons (22) and (86). Install piston (22) in piston (86) as shown.

NOTE: On valve groups (A) and (B), a pin goes inside inner spring (85).

f. Install shims (21) and springs (85) and (20) in the end of piston (22).

g. Install piston (86) in body (26). Install body (26) on the pressure control valve. Install two screws (28) that hold the body in position.

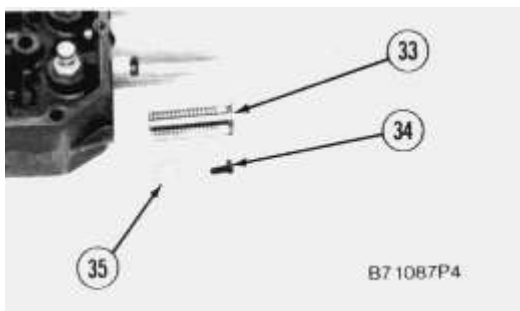

35. Put clean SAE 30 oil on piston (33). Install piston (33) in the pressure control valve. Install the washer and bolt (34) that hold the piston in place.

Thank you so much for reading.
Please click the “Buy Now!”
button below to download the
complete manual.



After you pay.

You can download the most
perfect and complete manual in
the world immediately.

Our support email:

ebooklibonline@outlook.com