

Product: TRUCK

Model: 797F TRUCK LTZ

Configuration: 797F Off-Highway Truck LTZ00001-UP (MACHINE) POWERED BY C175 Engine

Disassembly and Assembly 797F Tier 4 Off-Highway Truck Field Assembly

Media Number -M0090267-00

Publication Date -01/10/2018

Date Updated -18/10/2018

i07552353

Power Train - Install

SMCS - 3000; 4000; 4011; 4050; 7200; 7960

Reference: Special Instruction, "Visual Service Procedures - Colors and Symbols"M0066576

Parts and Specification Information

Note: Verify that all parts are shipped and undamaged for preparation of assembly. Missing or damaged parts can be ordered prior to assembly to avoid delays during assembly.

Table 1

Item	Part Number	Part Description	Qty	Specification	Approximate Weight
272-3349 Drive Shaft Gp, 541-9406 Rear Suspension Ar, or 426-5356 Rear Suspension Ar, 272-3337 Power Train Ar, 446-9392 Transmission Ar, 149-3100 Transmission Mounting Gp, 336-7751 Drive Shaft Guard Gp, 149-3054 Rear Suspension Gp, 379-8150 Sensor Mounting Gp, or 383-1160 Sensor Mounting Gp 320-6868 Camera and Mounting Gp, 351-3820 Sound Suppression Ar					
1	272-3337	Power Train Ar	1		42200 kg (93000 lb)
2	358-1398	Upper Link Gp	2		460 kg (1020 lb)
3	200-0885	Lower Link Gp	2		454 kg (1000 lb)
4	467-2620	O-Ring Seal	16		
5	156-9804	Pin	8	Apply NLG1#0 GREASE	62 kg (137 lb)
6	294-0099	Collet	16		
7	9X-8399	Hard Washers	62		

8	8T-0368	Bolts (M30X3.5X100- MM)	24	Tighten to 1800 ± 200 N·m (1330 ± 150 lb ft) Apply Tooling (B)	
9	446-9392	Transmission Ar	1	.	6677 kg (14720 lb)
10	8C-3236	Bolt	38		
11	7X-4781	O-Ring Seal	1		
12	284-4881	Slip Joint	1		288 kg (635 lb)
13	8T-0670	Bolt	8	Tighten to a torque of 1000 ± 125 N·m (737 ± 92 lb ft) in an alternating (X) pattern.	
14	337-4322	Plate As	1		
15	8T-4136	Bolt	45		
16	7X-7729	Washer	22		
17	293-5510	Plate As	1		
18	8T-4139	Bolt	12		
19	8T-4223	Hard Washer	44		
20	336-7746	Plate As	2		
21	337-4313	Plate As	1		
22	337-4319	Plate	1		
23	337-4316	Plate As	1		
24	363-6311	Plate	1		
25	336-7754	Plate As	1		
26	336-7757	Plate As	1		
27	8T-4121	Hard Washer	52		
28	289-8619	Rear Suspension Gp Right Hand	1		862 kg (1900 lb)
	426-5352	Rear Suspension Gp ⁽¹⁾ Right Hand	1		
28A	289-8620	Rear Suspension Gp Left Hand	1		862 kg (1900 lb)
	459-6749		1		

		Rear Suspension Gp ⁽²⁾ Left Hand			
29	192-4309	O-Ring Seal	8		
30	191-3628	Pin	4	Apply NLG1#0 GREASE	62 kg (137 lb)
31	191-3629	Collet	8		
32	157-0221	Suspension Cover	2		
33	157-0222	Hose Clamp	4		
34	5P-7466	Clip	2		
35	5P-8112	Grommet	2		
36	5P-7467	Clip	2		
37	340-9832	Plate	1		
38	329-3356	Nut	5		
39	1F-1609	Spacer	1		
40	5P-7469	Clip	4		
41	5P-8444	Grommet	4		
42	5P-7468	Clip	4		
43	5P-7465	Clip	1		
44	6V-1249	Grommet	1		
45	5P-7464	Clip	1		
46	8T-6868	Bolt	1		
47	6V-1868	Clip	1		
48	6V-1869	Grommet	1		
49	6V-1867	Clip	1		
50	8T-4956	Bolt	5		
51	5P-7470	Clip	1		
52	204-2281	Cable Strap	38		
53	5P-7703	Grommet	1		
54	5P-7471	Clip	1		
56	8T-6594	Bolt	4		
57	461-3299	Adapter	1		
58	6V-4590	O-Ring Seal	1		

59	8T-4194	Bolt	6		
63	375-3192	Clip	1		
64	370-1480	Grommet	1		
65	375-3193	Clip	1		
66	8T-4183	Bolt	4		
67	415-8650	Plate	1		
68	199-9692	Half Clamp	2		
83	347-7917	Object Detection Box Gp	4		
84	458-2206	Bracket As	4		
85	8T-4195	Bolt	8		
86	349-4915	Bracket	4		
87	8T-4186	Bolt	16		
88	6V-7744	Locknut	16		
89	8T-4195	Bolt	16		
90	265-9596	Hard Washer	16		
91	380-4489	Plate	4		
92	204-8000	Cable Tie Mounting	5		
93	348-9537	Plate As	1		
94	336-6684	Camera Gp	1		
95	324-3352	Wiring Harness	2		
96	130-5301	Clip	4		
97	200-6345	Mount	13		
98	344-5675	Nut	2		
99	8T-4195	Bolt	4		
100	149-0912	Plate	2		
101	286-1876	Position Sensor Gp	2		
102	7W-2033	Clip	1		
103	7W-2034	Clip	1		
104	8T-4648	Bolt	1		

105	5V-9221	Spacer	1		
106	6V-6783	Clip	1		
107	157-6199	Grommet	1		
108	6V-6782	Clip	1		
109	216-7557	Clip	1		
110	218-3258	Grommet	1		
111	216-7558	Clip	1		
112	462-7221	Plate As	1		
113	479-2172	Bolt As	2		
114	230-7732	Cable Tie Mounting	2		
115	8T-4174	Bolt	1		

⁽¹⁾ use with **426-5356** Rear Suspension Ar

⁽²⁾ use with **426-5356** Rear Suspension Ar

Installation Procedure

Table 2

Required Tools			
Tool	Part Number	Part Description	Qty
A	176-6544	Collet Gauge Suspension Link	1
B	-	Loctite C5A Copper Anti-Seize	-
C	384-8916 ⁽¹⁾	Hydraulic Torque Wrench Gp	1
	385-8467	Hydraulic Pump and Motor Gp	1
	385-8471	Wrench Link	1
D	9U-7489	Lift Stand	2
	447-0910	Electric Hydraulic Pump Gp (115V)	2
	447-0911	Electric Hydraulic Pump Gp (230V)	2
E	169-3687	Lifting Bracket Gp	1
F	200-4279	Collet Gauge Suspension Cylinder	1
G	1U-6396	O-Ring Assembly Compound	1
H	1U-9202	Lever Puller Hoist Gp	1
J	189-0408	Shackle As	2

⁽¹⁾ 385-3996 Hydraulic Torque Wrench Gp can be used in place of this tool.

Start By:

- a. Install the cooling system package

Note: Remove all protective shipping covers, flanges, plugs, caps, clamps, cable straps, and material. Retain the bolts, washers, clamps, flanges, and O-ring seals.

Note: Clean all mounting and contact surfaces free of wax, dirt, debris, paint, and grease. Chase all threaded holes with an appropriately sized tap.



Personal injury or death can result from improper lifting or blocking.

When a hoist or jack is used to lift any part or component, stand clear of the area. Be sure the hoist or jack has the correct capacity to lift a component. Install blocks or stands before performance of any work under a heavy component.

Approximate weights of the components are shown. Clean all surfaces where parts are to be installed.



Do not attempt to assemble this machine until you read and you understand the assembly instructions.

Improper assembly procedures could result in injury or death.

Remove the Tie Down Eyes from the Frame



Typical view of the location of the tie down eyes to be removed

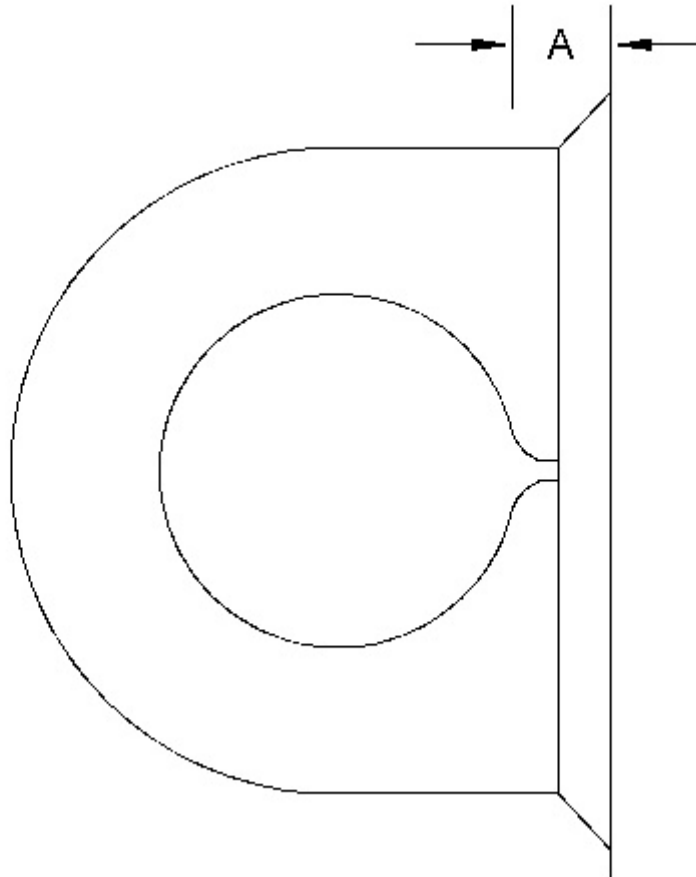

(A) 15 ± 2 mm (0.59055 ± 0.07874 inch)

NOTICE

Do not grind through the weld or the parent material of the frame.

1. Use a torch or a carbon arc method in order to remove the four tie down eyes from the frame. Leave the weld and the parent material to Dimension (A).

Note: there are two tie down eyes on each side of the chassis.

2. Clean all the areas that were affected in Step 1. Paint the affected areas in order to inhibit rust.

Rear Suspension Links Install

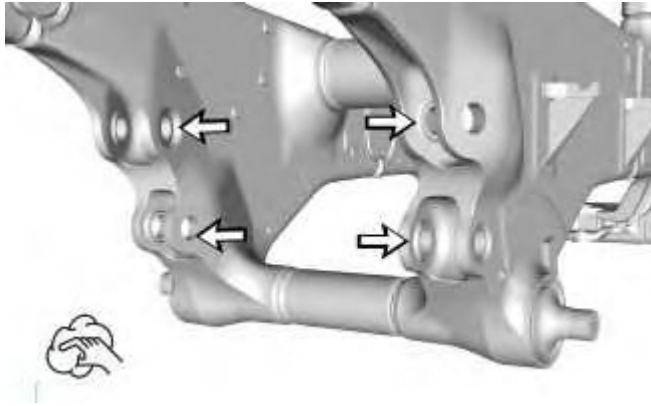

Illustration 3

g03838605

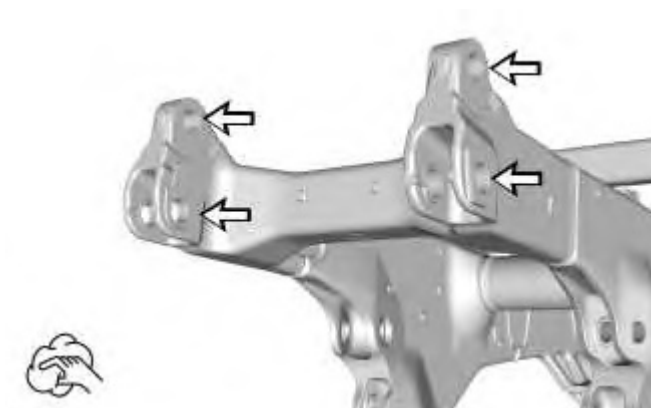

Illustration 4

g03841290

1. Clean the pin bores at the rear of the truck frame free of wax, dirt, debris, paint, and grease.



Illustration 5

g03838599

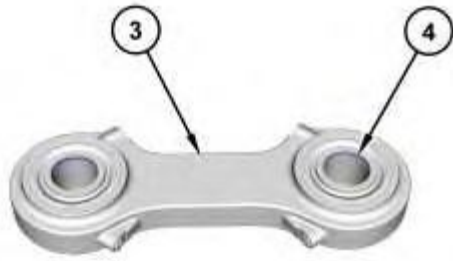

Illustration 6

g03838582

- (3) **200-0885** Lower Link Gp
(4) **467-2620** O-Ring Seal

2. Clean the bearing bores on both ends of lower suspension link assembly (3) free of wax, dirt, debris, paint, and grease. Install four O-ring seals (4) into lower suspension link assembly (3). Repeat this step for the remaining upper and lower suspension link assemblies.
-

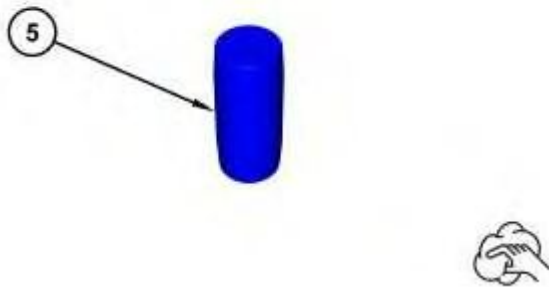
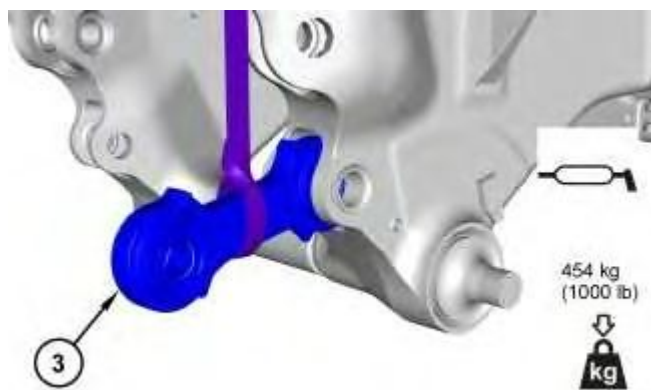

Illustration 7

g03838691

- (5) **156-9804** Pin

3. Clean eight pins (5) free of wax, dirt, debris, paint, and grease. Repeat this step for the remaining suspension link pins.
-



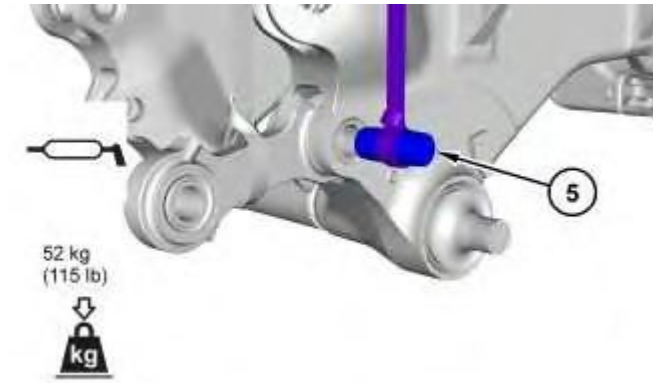

Illustration 9

(3) **200-0885** Lower Link Gp

(5) **156-9804** Pin

4. Apply NLG1#0 GREASE onto the bearing bores. Use a suitable lifting device to position lower suspension link assembly (3) onto the frame. The weight of lower suspension link assembly (3) is approximately 454 kg (1000 lb). Align the pin and bearing bores. Use a suitable lifting device to install one pin (5). The weight of one pin (5) is approximately 52 kg (115 lb).

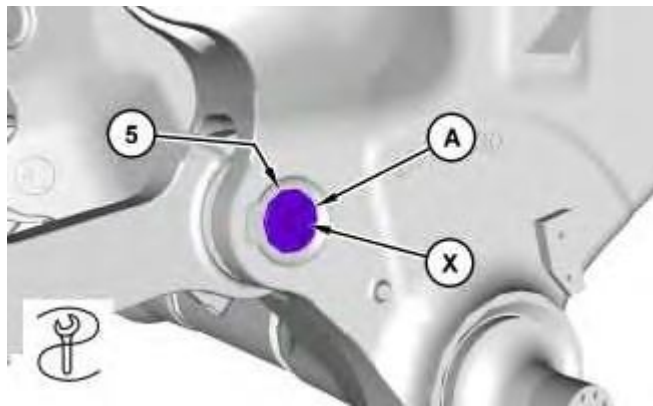
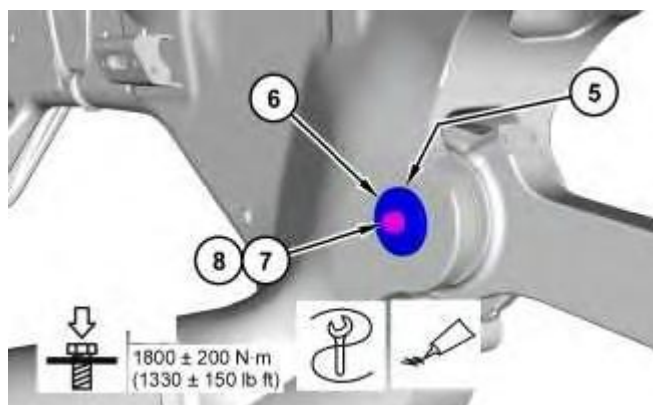

Illustration 10



- (5) **156-9804** Pin
- (6) **294-0099** Collet
- (7) **9X-8399** Washer
- (8) **8T-0368** Bolt

5. Install Tooling (A). Tighten the bolt until pin (5) is fully engaged with Tooling (A).

a. Install one collet (6).

Note: Do not apply Anti-Seize Compound to collet (6).

b. Apply Tooling (B) onto one bolt (8). Install one hard washer (7) and one bolt (8).

c. Use Tooling (C) to tighten bolt (8) to a torque of 1800 ± 200 N·m (1330 ± 150 lb ft).

d. Strike the collet with a hammer to cause the torque to drop to less than 950 N·m (700 lb ft).

e. Use Tooling (C) to tighten bolt (8) to a torque of 1800 ± 200 N·m (1330 ± 150 lb ft).

f. Strike the collet with a hammer to cause the torque to drop to less than 1600 N·m (1180 lb ft).

g. Use Tooling (C) to tighten bolt (8) to a torque of 1800 ± 200 N·m (1330 ± 150 lb ft).

h. Remove Tooling (A).

i. Repeat Step 5.a through Step 5.g for the opposite side of the lower suspension link.

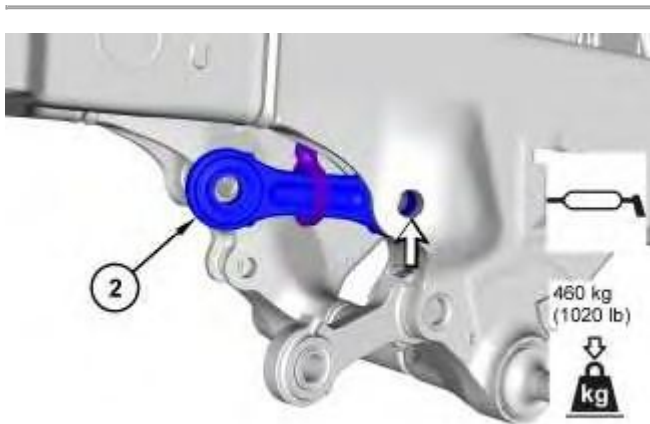



Illustration 13

g03838716

- (2) **358-1398** Upper Link Gp
 (5) **156-9804** Pin

6. Apply NLG1#0 GREASE onto the bearing bores. Use a suitable lifting device to position upper suspension link assembly (2) onto the frame. The weight of upper suspension link assembly (2) is approximately 460 kg (1020 lb). Align the pin and bearing bores. Use a suitable lifting device to install one pin (5). The weight of one pin (5) is approximately 52 kg (115 lb).

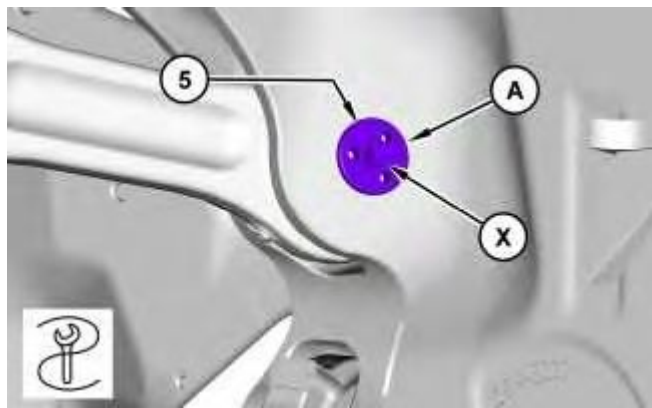

Illustration 14

g03838721

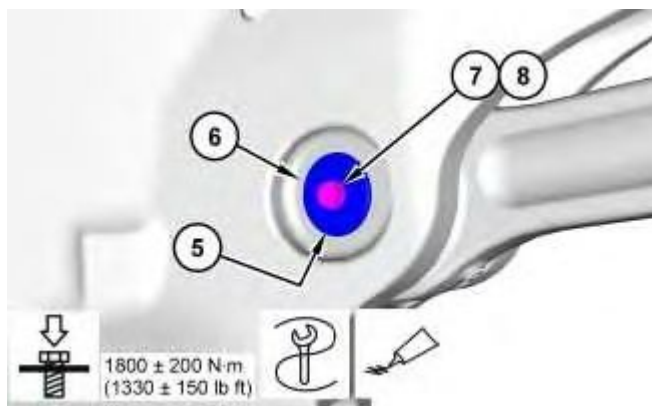

Illustration 15

g03838849

- (5) **156-9804** Pin
- (6) **294-0099** Collet
- (7) **9X-8399** Washer
- (8) **8T-0368** Bolt

7. Install Tooling (A). Tighten the bolt until pin (5) is fully engaged with Tooling (A).

a. Install one collet (6).

Note: Do not apply Anti-Seize Compound to collet (6).

b. Apply Tooling (B) onto one bolt (8). Install one hard washer (7) and one bolt (8).

c. Use Tooling (C) to tighten bolt (8) to a torque of 1800 ± 200 N·m (1330 ± 150 lb ft).

d. Strike the collets with a hammer to cause the torque to drop to less than 950 N·m (700 lb ft).

e. Use Tooling (C) to tighten bolt (8) to a torque of 1800 ± 200 N·m (1330 ± 150 lb ft).

f. Strike the collet with a hammer to cause the torque to drop to less than 1600 N·m (1180 lb ft).

g. Use Tooling (C) to tighten bolt (8) to a torque of 1800 ± 200 N·m (1330 ± 150 lb ft).

h. Remove Tooling (A).

i. Repeat Step 7.a through Step 7.g for the opposite side of the lower suspension link.

8. Repeat Step 4 through Step 7.i for the opposite side of the truck frame.

Rear Axle Install

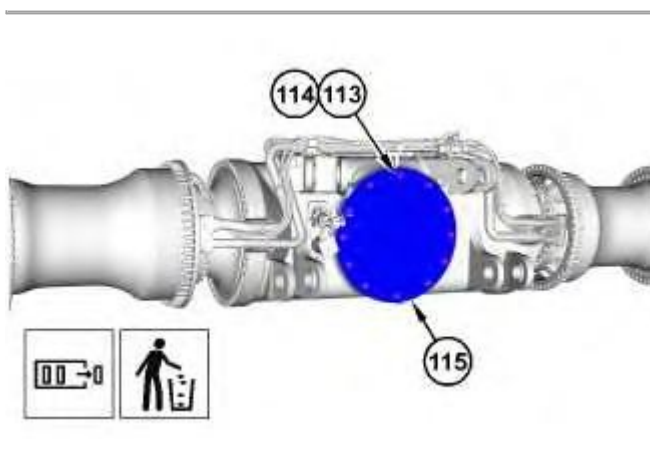

Illustration 16

g03886000

1. Remove twelve bolts (113) and twelve washers (114). Remove cover (115).

Note: To prevent contamination, the transmission shipping cover can be removed after the rear axle is installed and before the transmission is installed.

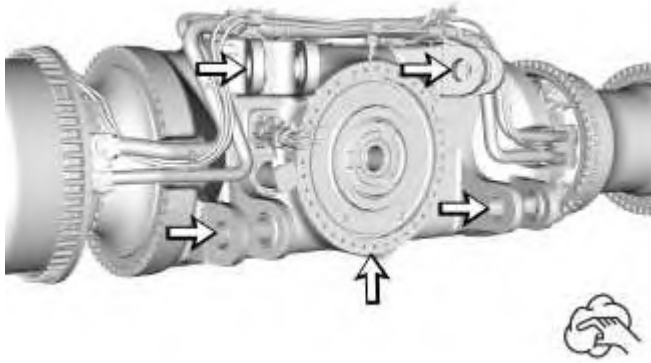

Illustration 17

g03838727

2. Clean the pin bores for the suspension links and the transmission mounting surface of the rear axle free of wax, dirt, debris, paint, and grease.

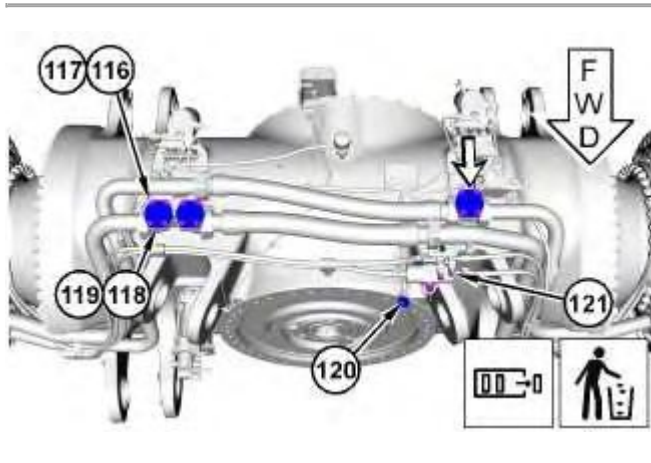
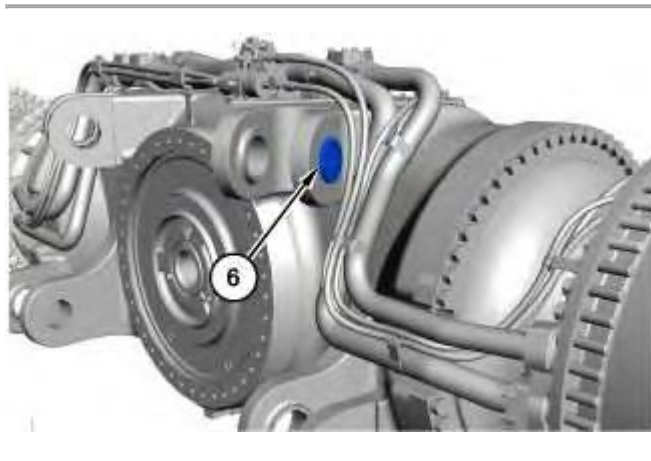

Illustration 18

g03885672

Note: Steep Grade configuration only. Do not remove the cover and hardware from the left-hand side of the brake hydraulic lines for the shallow grade configuration.

3. Remove twelve bolts (116), twelve washers (117), four covers (118), and four O-ring seals (119) from the brake hydraulic lines. Remove one receptacle plug (120) and three caps (121).



4. Install one collet (6) onto the upper left suspension link mounting location.

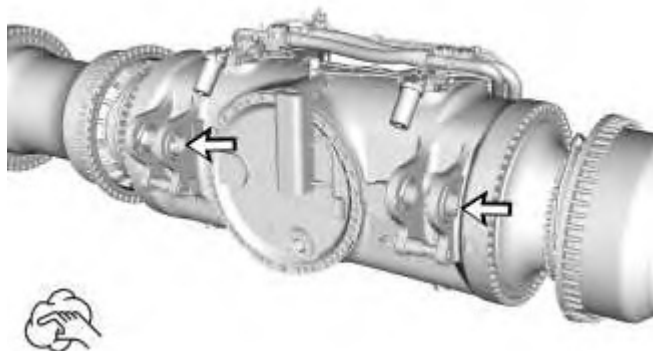

Illustration 20

5. Clean the pin bores for the rear suspension cylinders free of wax, dirt, debris, paint, and grease.

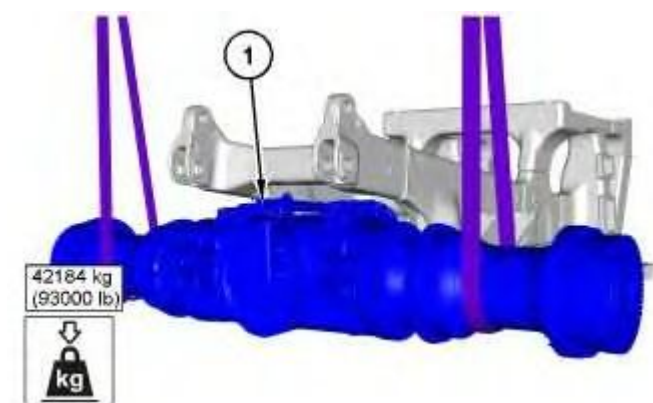

Illustration 21

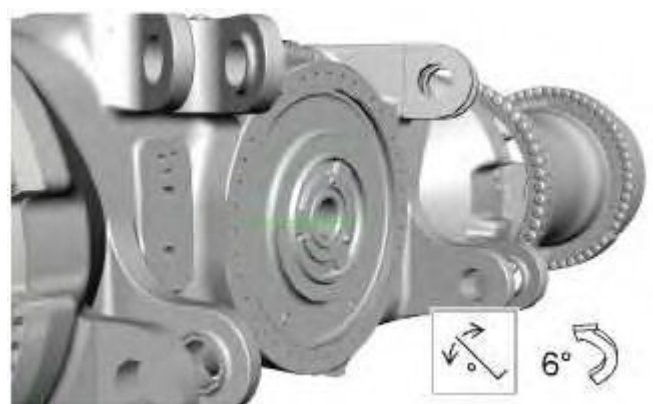

Illustration 22

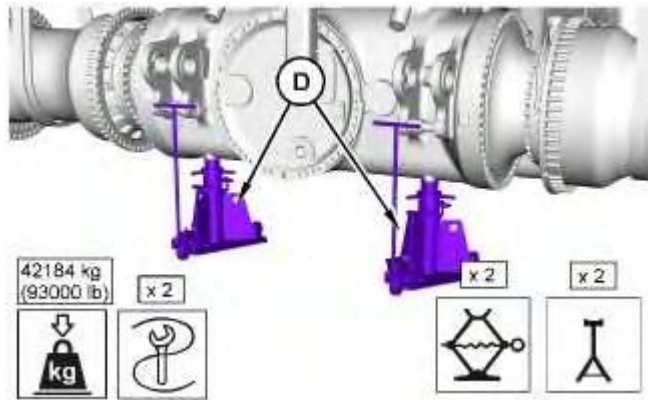

Illustration 23

g03886003

(1) **272-3337** Power Train Ar

6. Attach a suitable lifting device onto rear axle (1). The weight of rear axle (1) is approximately 42184 kg (93000 lb).
7. Use the suitable lifting device to position rear axle (1) at the rear of the truck frame with the transmission mating face at 6 degree angle from vertical (84 degree angle from horizontal). Align the pin bores with the pin bores of the suspension links. Install Tooling (D).

Note:

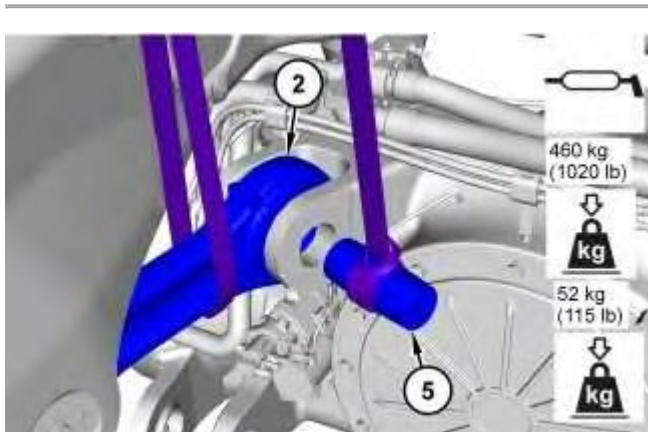

Illustration 24

g03839152

(2) **358-1398** Upper Link Gp

(5) **156-9804** Pin

8. Apply NLG1#0 GREASE onto the bearing bores. Use a suitable lifting device to align the bearing bore of upper suspension link assembly (2) with the pin bore on the rear axle. The weight of upper suspension link assembly (2) is approximately 460 kg (1020 lb). Use a suitable lifting device to install one pin (5). The weight of one pin (5) is approximately 52 kg (115 lb). Repeat this step for the remaining upper suspension link assembly.

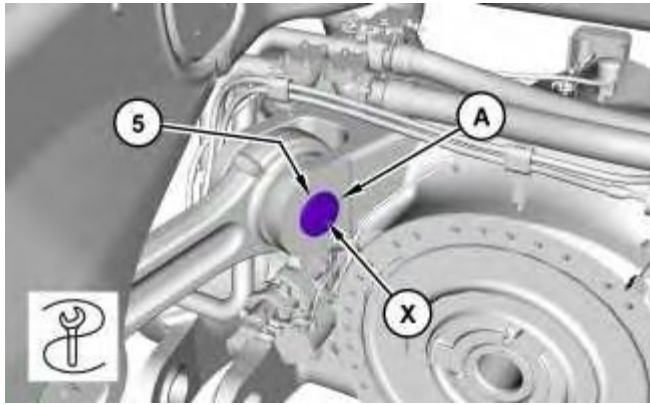

Illustration 25

g03839190

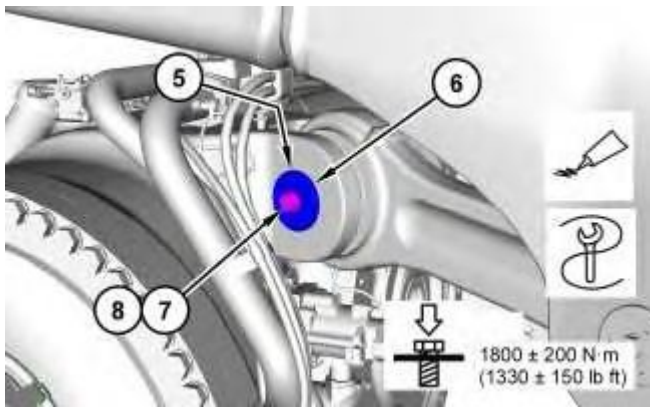

Illustration 26

g03839191

- (5) **156-9804** Pin
- (6) **294-0099** Collet
- (7) **9X-8399** Washer
- (8) **8T-0368** Bolt

9. Install Tooling (A). Tighten the bolt until pin (5) is fully engaged with Tooling (A).
 - a. Install one collet (6).

Note: Do not apply Anti-Seize Compound to collet (6).
 - b. Apply Tooling (B) onto one bolt (8). Install one hard washer (7) and one bolt (8).
 - c. Use Tooling (C) to tighten bolt (8) to a torque of 1800 ± 200 N·m (1330 ± 150 lb ft).
 - d. Strike the collets with a hammer to cause the torque to drop to less than 950 N·m (700 lb ft).
 - e. Use Tooling (C) to tighten bolt (8) to a torque of 1800 ± 200 N·m (1330 ± 150 lb ft).
 - f. Strike the collet with a hammer to cause the torque to drop to less than 1600 N·m (1180 lb ft).
 - g. Use Tooling (C) to tighten bolt (8) to a torque of 1800 ± 200 N·m (1330 ± 150 lb ft).

h. Remove Tooling (A).

i. Repeat Step 9.a through Step 9.g for the opposite side of the upper suspension link.

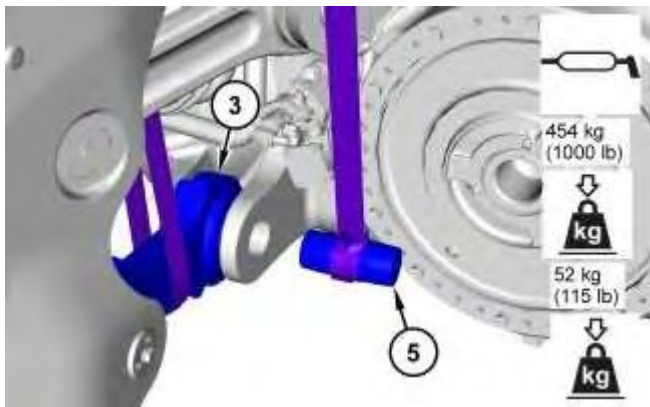

Illustration 27

g03839162

(3) **200-0885** Lower Link Gp

(5) **156-9804** Pin

10. Apply NLG1#0 GREASE onto the bearing bores. Use a suitable lifting device to align the bearing bore of lower suspension link assembly (3) with the pin bore on the rear axle. The weight of lower suspension link assembly (3) is approximately 454 kg (1000 lb). Use a suitable lifting device to install one pin (5). The weight of one pin (5) is approximately 52 kg (115 lb). Repeat this step for the remaining lower suspension link assembly.

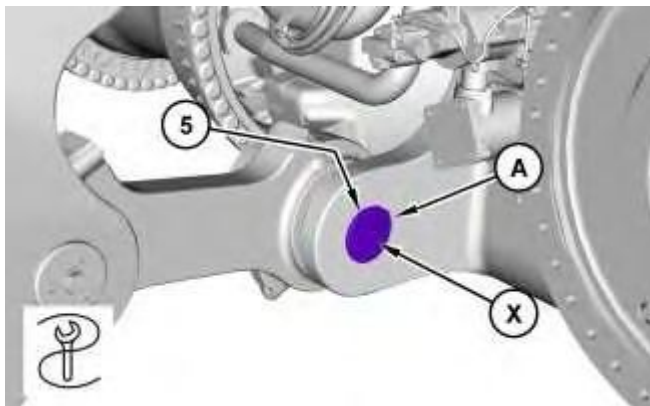

Illustration 28

g03839192

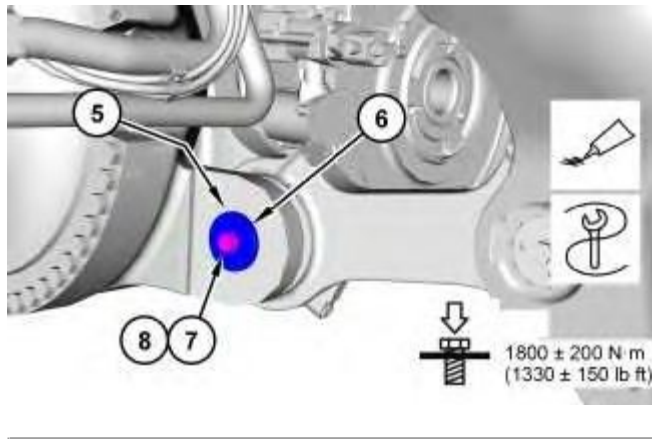

Illustration 29

g03839193

- (5) **156-9804** Pin
- (6) **294-0099** Collet
- (7) **9X-8399** Washer
- (8) **8T-0368** Bolt

11. Install Tooling (A). Tighten the bolt until pin (5) is fully engaged with Tooling (A).
 - a. Install one collet (6).

Note: Do not apply Anti-Seize Compound to collet (6).
 - b. Apply Tooling (B) onto one bolt (8). Install one hard washer (7) and one bolt (8).
 - c. Use Tooling (C) to tighten bolt (8) to a torque of 1800 ± 200 N·m (1330 ± 150 lb ft).
 - d. Strike the collets with a hammer to cause the torque to drop to less than 950 N·m (700 lb ft).
 - e. Use Tooling (C) to tighten bolt (8) to a torque of 1800 ± 200 N·m (1330 ± 150 lb ft).
 - f. Strike the collet with a hammer to cause the torque to drop to less than 1600 N·m (1180 lb ft).
 - g. Use Tooling (C) to tighten bolt (8) to a torque of 1800 ± 200 N·m (1330 ± 150 lb ft).
 - h. Remove Tooling (A).
 - i. Repeat Step 11.a through Step 11.g for the opposite side of the lower suspension link.
12. Repeat Step 8 through Step 11.i for the opposite side of the truck frame.
13. Fill the joints for the suspension links with 80W - 90 Gear Oil by removing the plugs from the links. Add gear oil through the grease fitting until oil comes out of the first vent hole. Plug the first vent hole and continue adding oil until oil comes out of the second vent hole. Remove the plug from the first vent hole in order to burp the joint. Do not overfill as excess oil may force the seals out of position resulting in failure.

Note: Under arctic conditions fill suspension link joints with EMGARD EP75W-90 Oil.

14. After 50 hours of operation, refill the suspension link with 80W - 90 Gear Oil and tighten the collet bolts to a torque of 1800 ± 200 N·m (1328 ± 148 lb ft). Refer to Operation and Maintenance Manual, "Link and Rear Cylinder (Suspension) - Check".

Transmission Install

1. Use the following steps to remove the **272-3461** Rear Axle Oil Cooler Ar, if equipped.

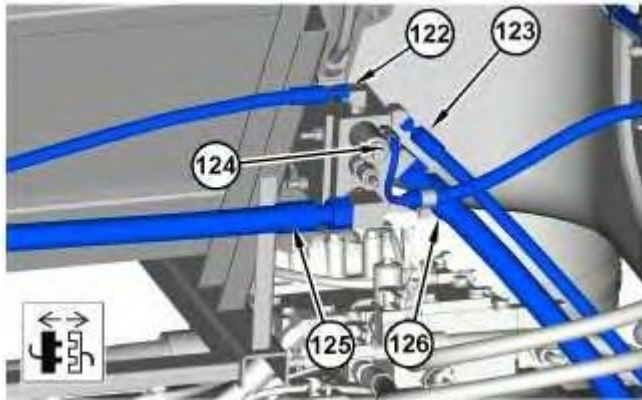

Illustration 30

g06018595

- (122) **188-2762** Hose As
- (123) **348-9154** Hose As
- (124) **422-6729** Rear Chassis Harness As
- (125) **432-2149** Hose As
- (126) **422-1069** Hose As

- a. Disconnect one hose assembly (122), one hose assembly (123), one harness assembly (124), one hose assembly (125), and one hose assembly (126).

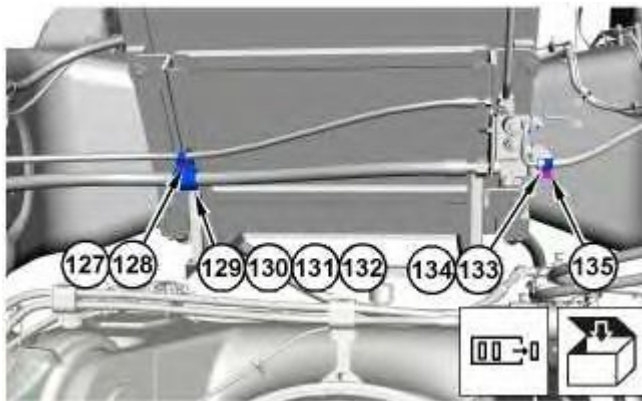

Illustration 31

g06018618

- (127) **8T-4136** Bolt
- (128) **8T-4121** Hard Washer
- (129) **5P-7469** Clip
- (130) **5P-7468** Clip
- (131) **5P-8444** Grommet
- (132) **6D-4246** Clip
- (133) **8T-4185** Bolt

Thank you so much for reading.
Please click the “Buy Now!”
button below to download the
complete manual.



After you pay.

You can download the most
perfect and complete manual in
the world immediately.

Our support email:

ebooklibonline@outlook.com