

Product: COMPACT WHEEL LOADER

Model: 907H COMPACT WHEEL LOADER MJF

Configuration: 907H Wheel Loader MJF00001-UP (MACHINE) POWERED BY 3044C Engine

Disassembly and Assembly 906, 907 and 908 Compact Wheel Loaders Power Train

Media Number -KENR5211-04

Publication Date -01/06/2012

Date Updated -26/04/2017

i06893674

Transfer Drive Group (Hydrostatic) (High Speed) - Disassemble

SMCS - 3159-015-H7; 4350-015-HZ

Disassembly Procedure

Table 1

Required Tools			
Tool	Part Number	Part Description	Qty
A	439-3940	Bracket As	2
B	8B-7554	Puller Gp	1
	6V-1819	Bolt	1
	8T-0292	Bolt	1
C	1P-0469	Drive Plate	1
D	1P-0471	Drive Plate	1

Start By:

- a. Remove the Drive Shaft. Refer to Disassembly and Assembly Manual, "Drive Shaft - Remove and Install".
- b. Remove the Piston Motor. Refer to Disassembly and Assembly Manual, "Piston Motor (Hydrostatic) - Remove".

NOTICE

Care must be taken to ensure that fluids are contained during performance of inspection, maintenance, testing, adjusting, and repair of the product. Be prepared to collect the fluid with suitable containers before opening any compartment or disassembling any component containing fluids.

Refer to Special Publication, NENG2500, "Dealer Service Tool Catalog" for tools and supplies suitable to collect and contain fluids on Cat® products.

Dispose of all fluids according to local regulations and mandates.



Personal injury can result from hydraulic oil pressure and hot oil.

Hydraulic oil pressure can remain in the hydraulic system after the engine has been stopped. Serious injury can be caused if this pressure is not released before any service is done on the hydraulic system.

Make sure all of the work tools have been lowered to the ground, and the oil is cool before removing any components or lines. Remove the oil filler cap only when the engine is stopped, and the filler cap is cool enough to touch with your bare hand.

1. Drain the transfer drive oil into a suitable container. The capacity of the transfer drive is 1.3 L (0.3 US gal).

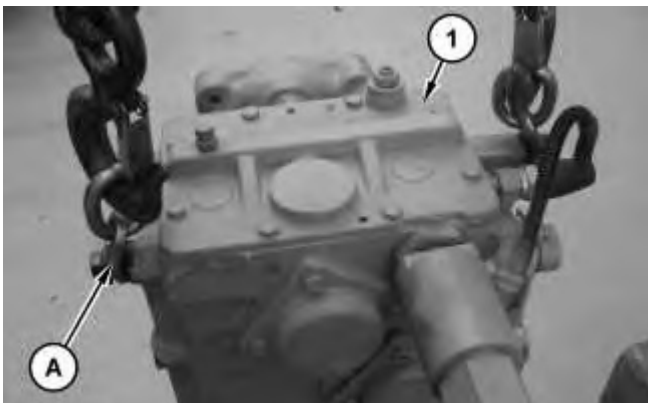

Illustration 1

g01620410

2. Install Tooling (A) to transfer drive group (1).
-

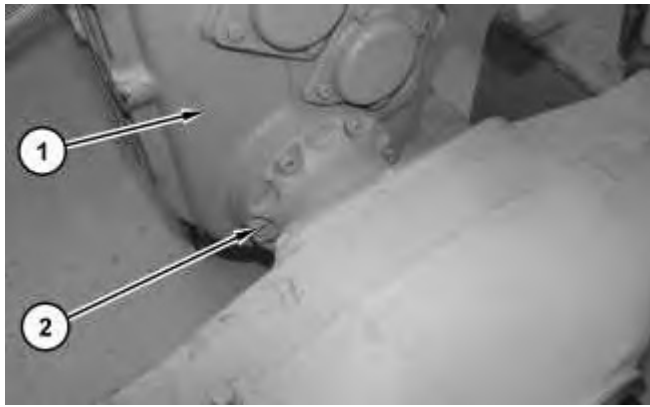

Illustration 2

g01620418

3. Remove bolts (2) to remove transfer drive group (1).

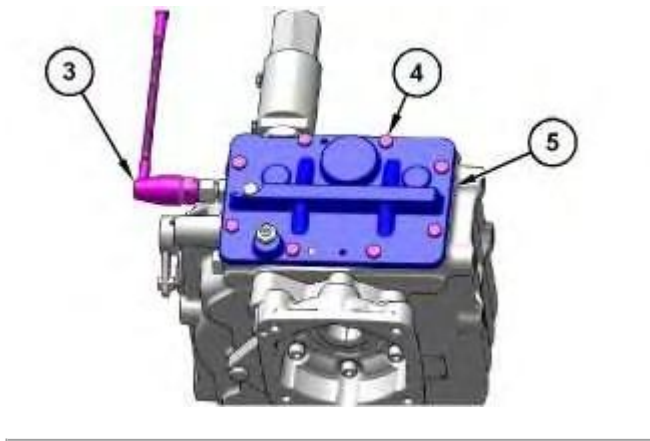

Illustration 3

g06158367

4. Remove switch assembly (3). Remove bolts (4). Use bolts (4) in pusher holes to remove cover (5).



Illustration 4

g01662853

5. Remove bolts (6). Remove flange (7).

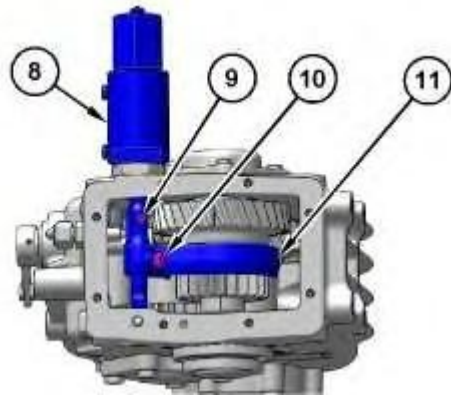

Illustration 5

g06158377

6. Remove bolt (9) and the bushing. Remove bolt (10). Remove shift cylinder (8). Remove fork (11).
-

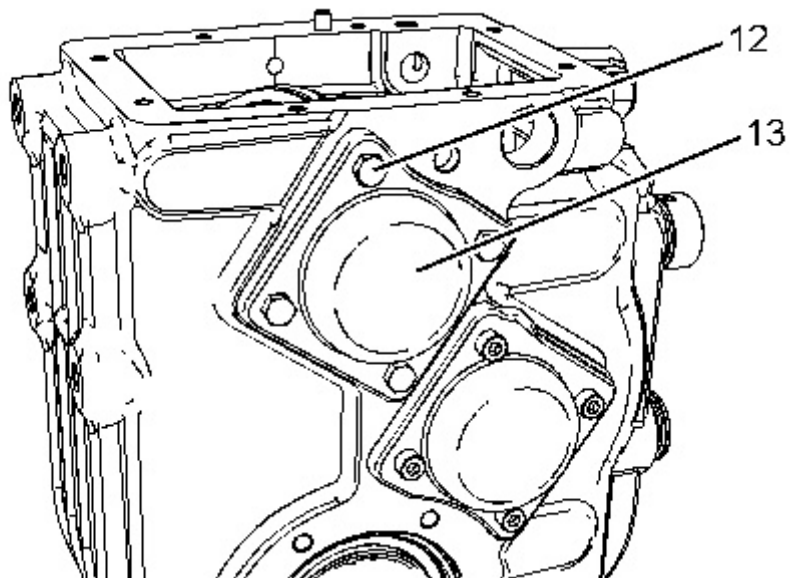

Illustration 6

g01662913

7. Remove bolts (12). Remove cover (13).
-

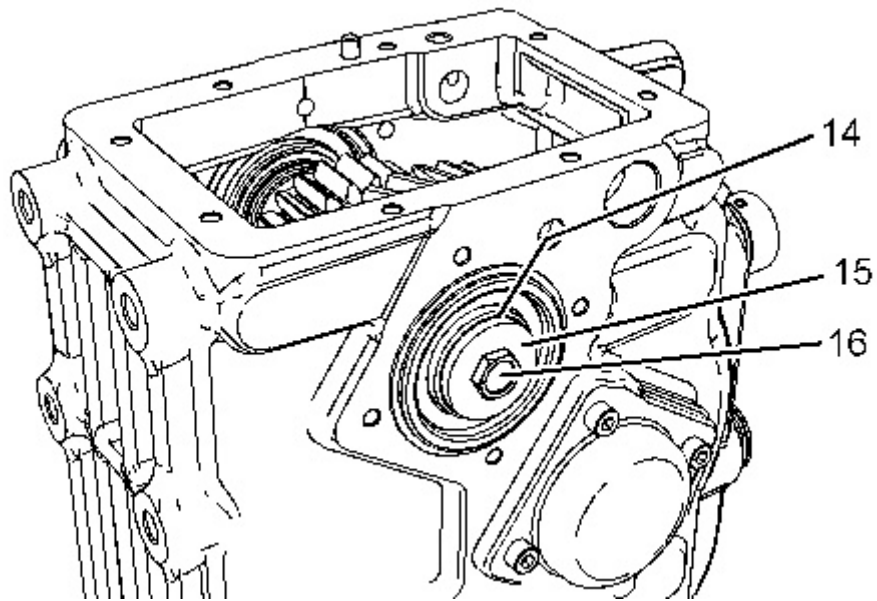

Illustration 7

g01662873

8. Remove bolt (16). Remove washer (15). Remove shims (14).

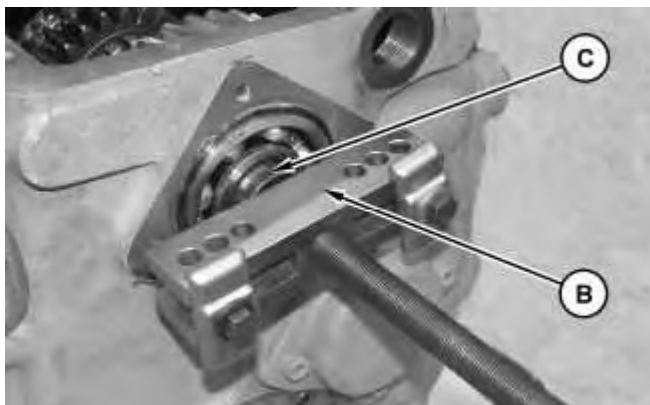

Illustration 8

g01621043

9. Install Tooling (C) and Tooling (B).

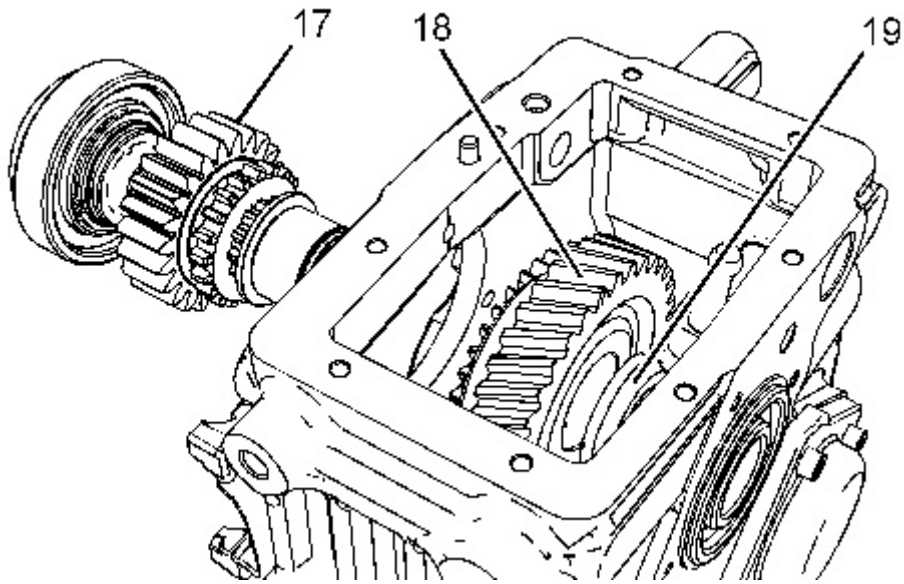

Illustration 9

g01662914

10. Remove shaft assembly (17). Remove gear (18) and spacer (19).

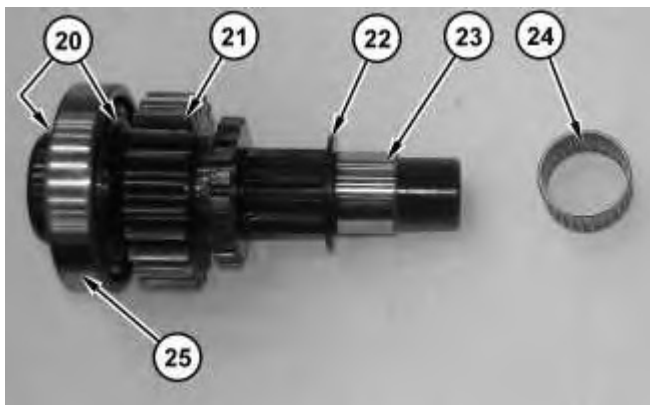

Illustration 10

g01662915

11. Remove needle bearing (24). Remove bearing race (23). Remove washer (22). Remove gear (21). Remove retaining rings (20). Remove bearing (25).

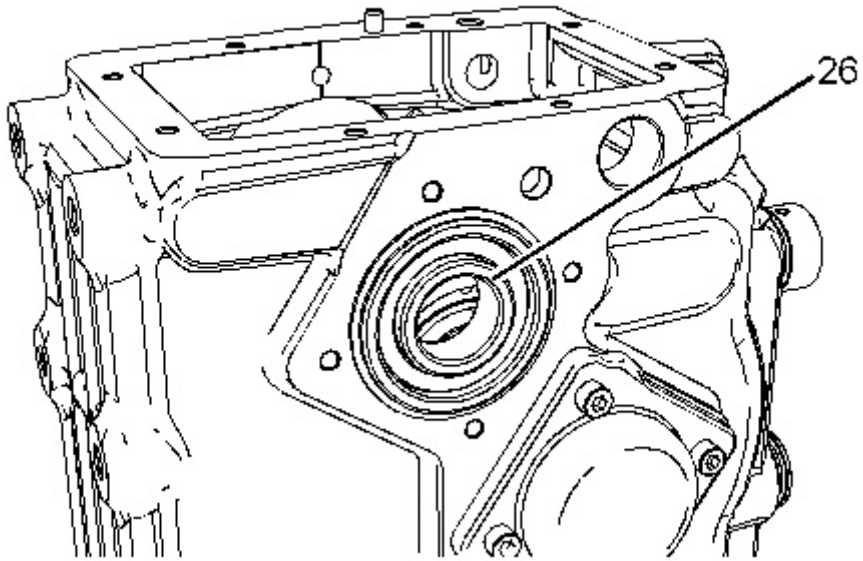

Illustration 11

g01662916

12. Remove bearing (26).

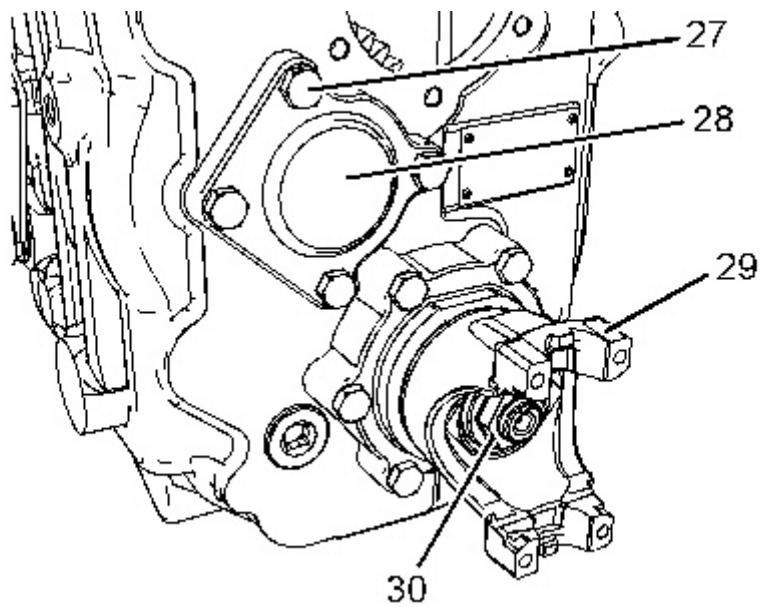

Illustration 12

g01662917

13. Remove bolts (27). Remove cover (28). Remove the nut and centering ring (30). Remove yoke (29).

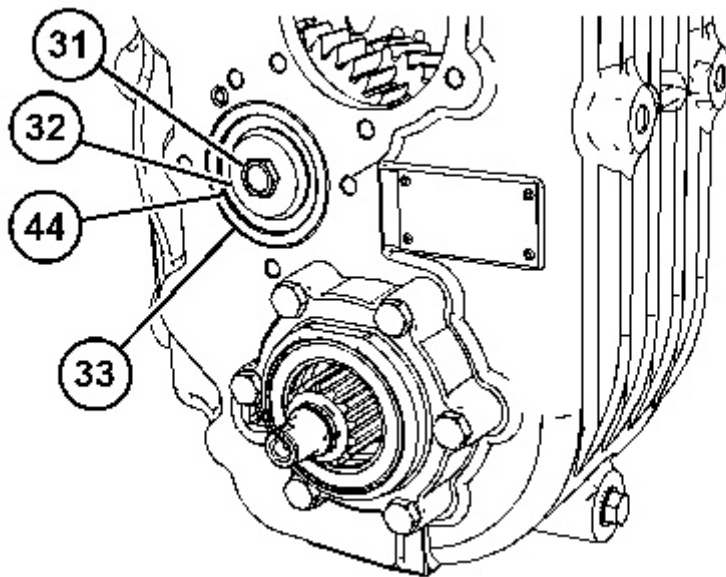

Illustration 13

g06160489

14. Remove bolt (31). Remove washer (32). Remove race (33). Bearing (44) is not removed at this time.

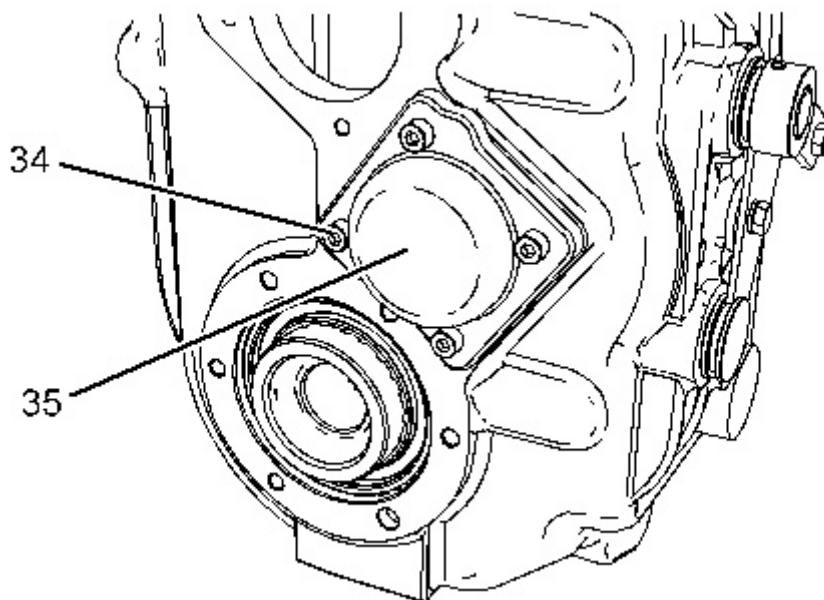

Illustration 14

g01662920

15. Remove bolts (34). Remove cover (35).
-

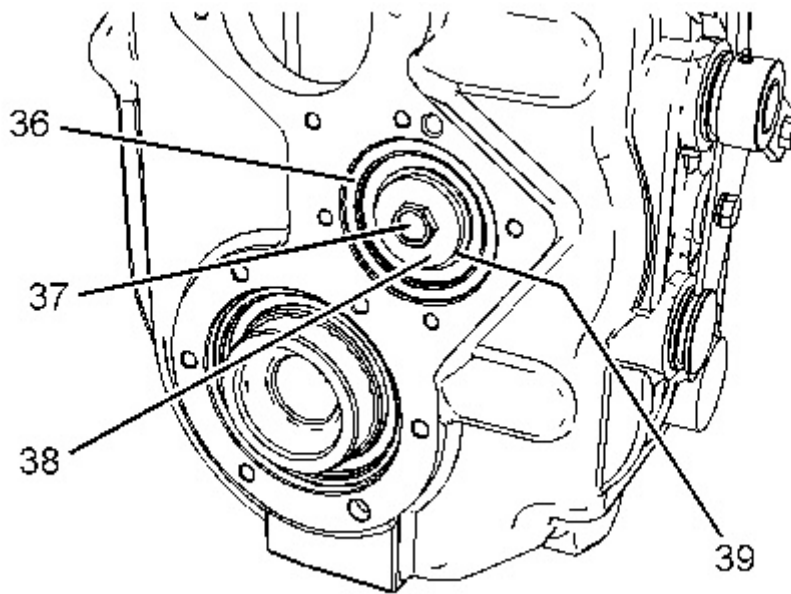

Illustration 15

g01662921

16. Remove shim (36). Remove bolt (37). Remove washer (38) and shims (39).

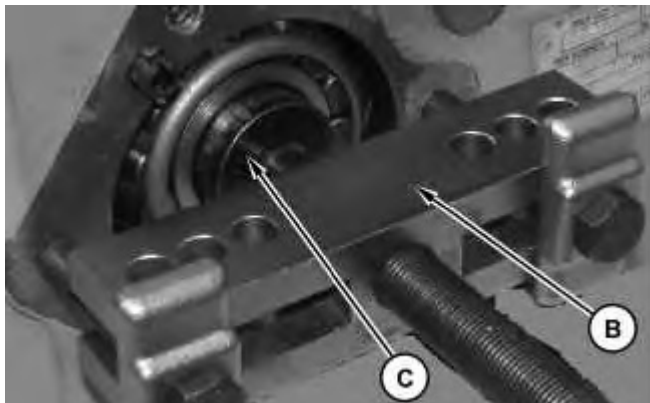

Illustration 16

g01622388

17. Attach Tooling (C) and Tooling (B) to remove the shaft. As you remove the shaft, bearing (44) may drop into the housing. Remove bearing (44).
-

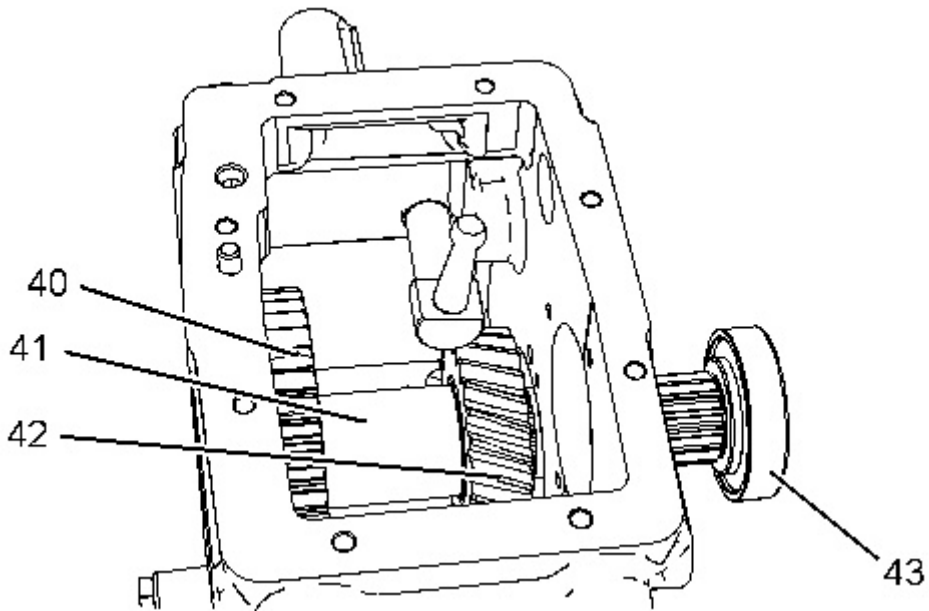

Illustration 17

g01662923

18. Remove shaft assembly (43). Remove gear (40) and gear (42). Remove spacer (41).

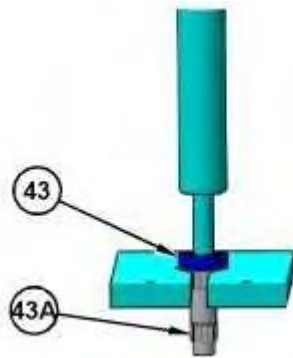

Illustration 18

g06160460

19. Use a suitable press to remove shaft assembly (43A) from bearing (43) .

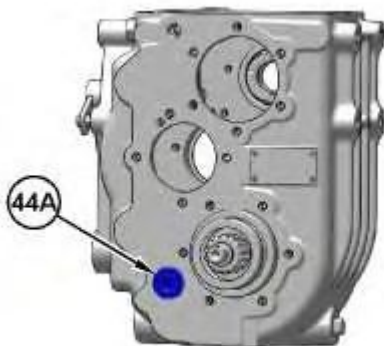

Illustration 19

g06160431

20. Remove plug (44A).



Illustration 20

g01662927

21. Remove bolts (46). Remove cover (45).

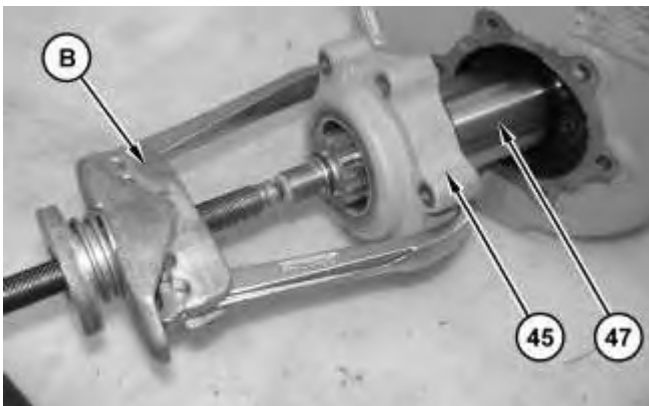

Illustration 21

g01667457

22. Use Tooling (B) to remove cover (45) from shaft assembly (47).



Illustration 22

g06159305



Illustration 23

g06159323

23. Remove seal (45A) from cover (45). Remove bearing (45B) from cover (45).
-

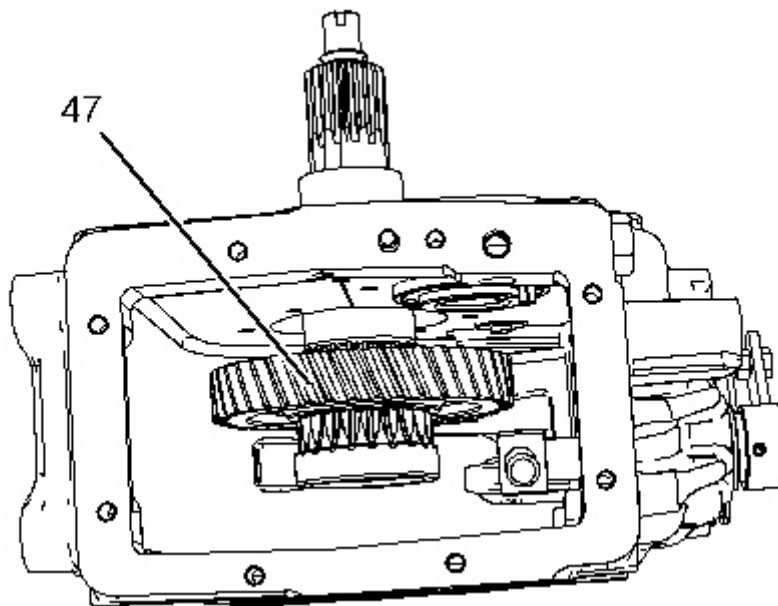

Illustration 24

g01662929

24. Remove shaft assembly (47).
-

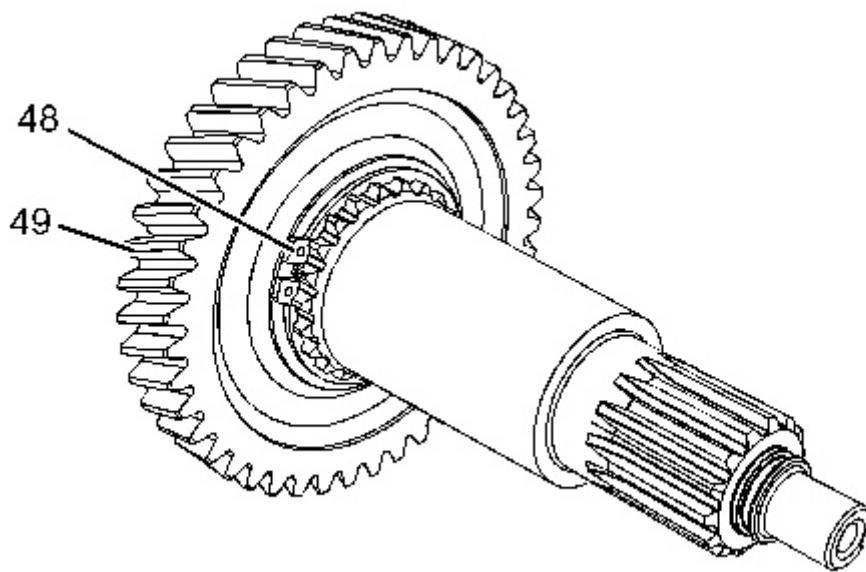

Illustration 25

g01662932

25. Remove retaining ring (48). Remove gear (49).

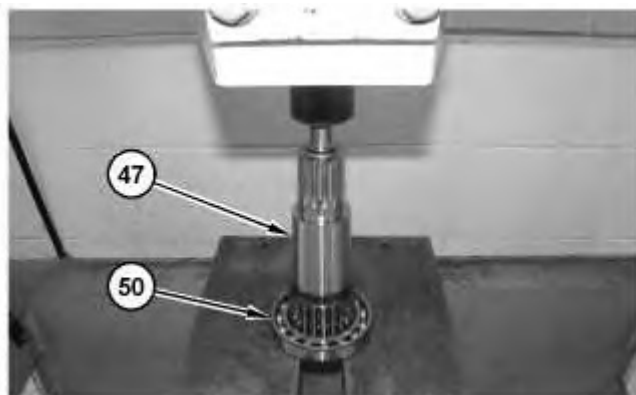

Illustration 26

g06159911

26. Use a suitable press to remove bearing (50) from shaft assembly (47).
-

Product: COMPACT WHEEL LOADER

Model: 907H COMPACT WHEEL LOADER MJF

Configuration: 907H Wheel Loader MJF00001-UP (MACHINE) POWERED BY 3044C Engine

Disassembly and Assembly 906, 907 and 908 Compact Wheel Loaders Power Train

Media Number -KENR5211-04

Publication Date -01/06/2012

Date Updated -26/04/2017

i06904640

Transfer Drive Group (Hydrostatic) (High Speed) - Assemble

SMCS - 3159-016-H7; 4350-016-HZ

Assembly Procedure

Table 1

Required Tools			
Tools	Part Number	Part Description	Qty
A	439-3940	Bracket As	2
E	154-9731	Thread Lock Compound	1
F	4C-9506	Retaining Compound	1
G	-	Loctite 401 Bonder Adhesive	-
H	6V-2012	Depth Micrometer	1
J	6V-6640	Sealant	1
K	1P-0510	Driver Gp	1
M	-	Loctite 567	1



Illustration 1

g06159976

1. Raise the temperature of bearing (50) and install bearing (50) on shaft assembly (47).

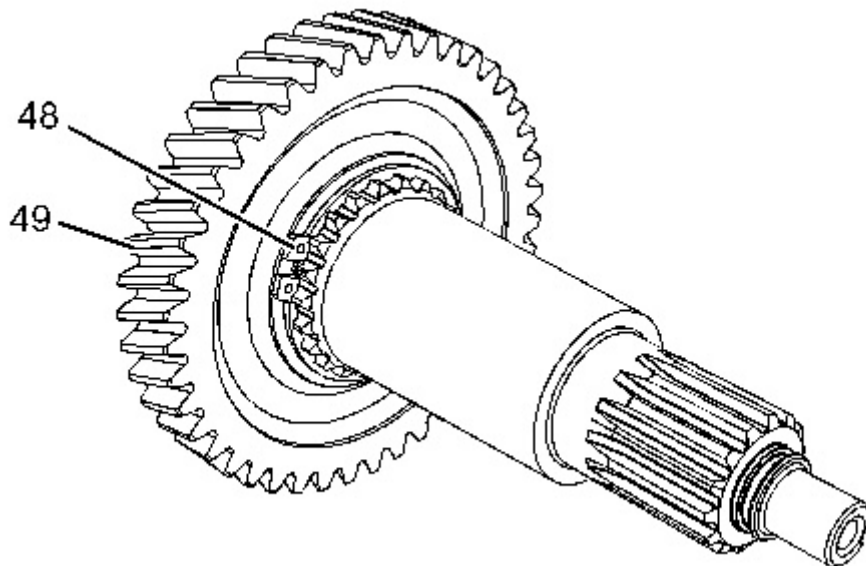

Illustration 2

g01662932

2. Install gear (49) and retaining ring (48).

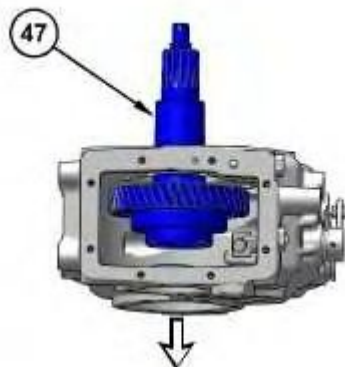

Illustration 3

g06159993

3. Install shaft assembly (47) through the top of the housing and position the bearing end through the correct opening.



Illustration 4

g06159323

4. Install bearing (45B) in cover (45).



Illustration 5

g06159305

5. Use Tooling (K) to install seal (45A) in cover (45).



Illustration 6

g01662927

6. Apply Tooling (J) to cover (45). Apply Tooling (M) to bolts (46). Position cover (45). Install bolts (46). Tighten bolts (46) to a torque of 50 N·m (37 lb ft).
-

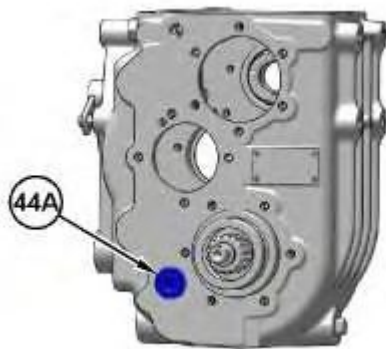

Illustration 7

g06160431

7. Install plug (44A). Tighten plug (44A) to a torque of 60 N·m (44 lb ft).
-

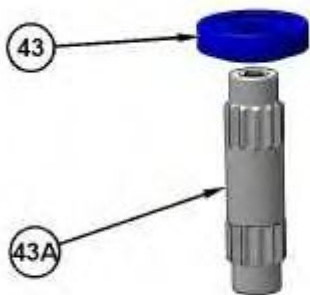

Illustration 8

g06160420

8. Raise the temperature of bearing (43) and install bearing (43) on shaft assembly (43A).
-

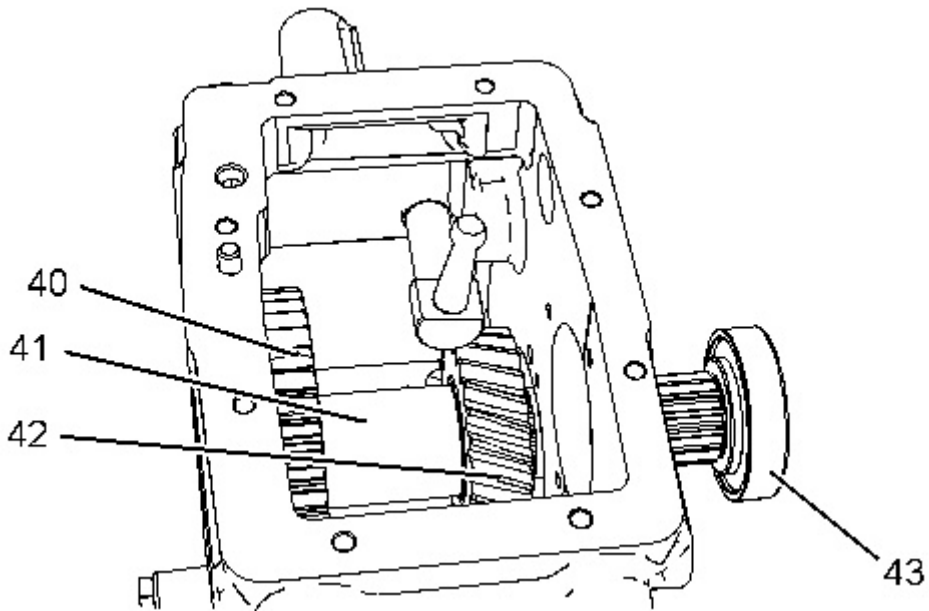

Illustration 9

g01662923

9. As you install shaft assembly (43), install gear (42), spacer (41), gear (40) onto shaft assembly (43).

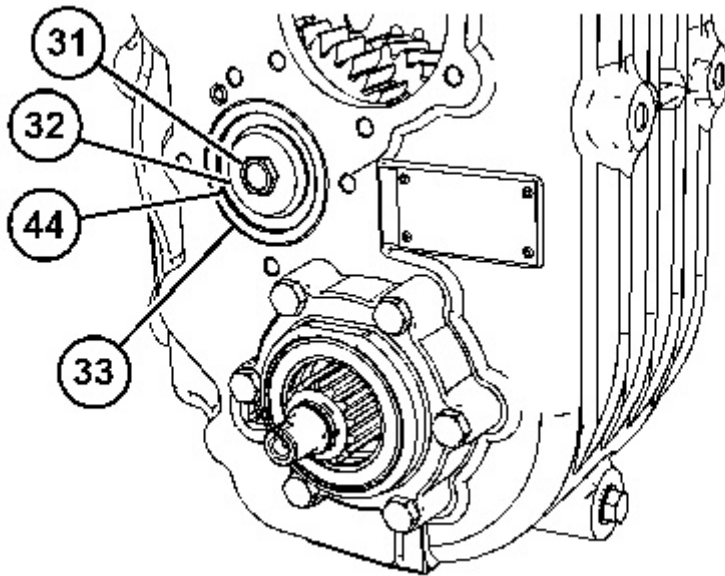

Illustration 10

g06160489

10. Raise the temperature of bearing (44) and install bearing (44). Install race (33). Apply Tooling (E) to bolt (31). Install washer (32) and bolt (31). Tighten bolt (31) to a torque of 139 N·m (103 lb ft).

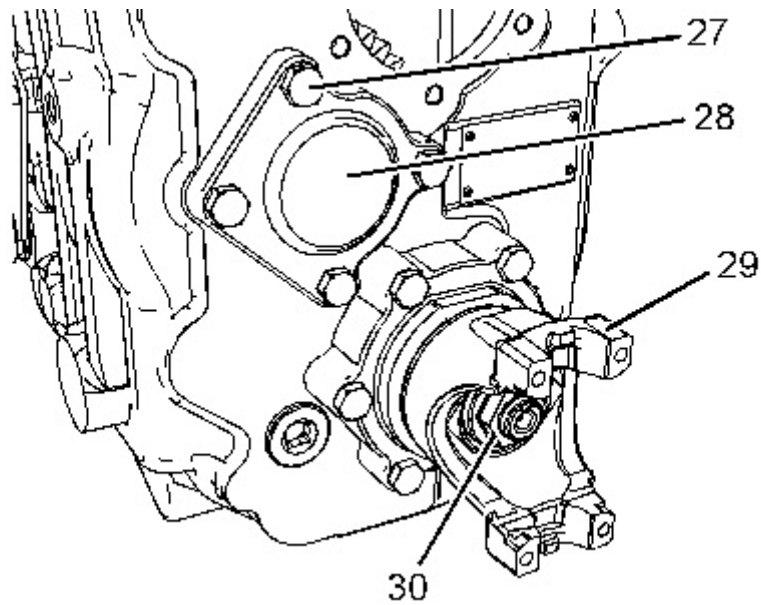

Illustration 11

g01662917

11. Apply Tooling (J) to cover (28). Apply Tooling (M) to bolts (27). Position cover (28) and install bolts (27). Tighten bolts (27) to a torque of 50 N·m (37 lb ft). Install yoke (29). Install the O-ring seals that are on the centering ring. Install the centering ring and ring nut (30). Tighten ring nut (30) to a torque of 190 N·m (140 lb ft).

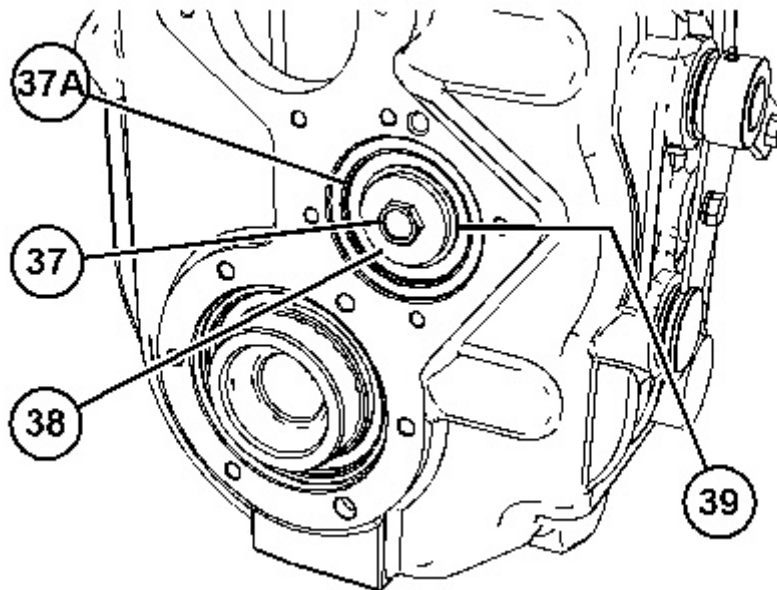

Illustration 12

g06160765

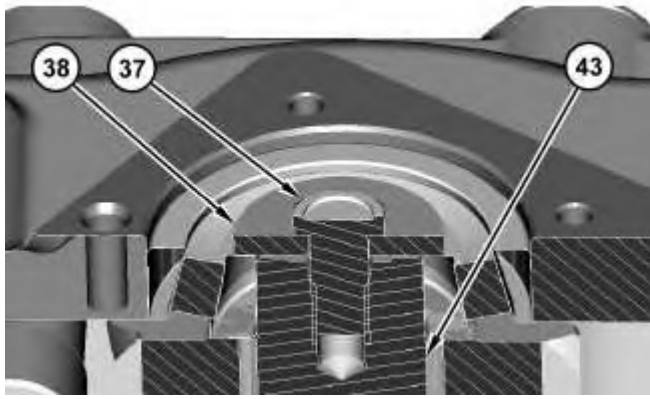

Illustration 13

g02364559

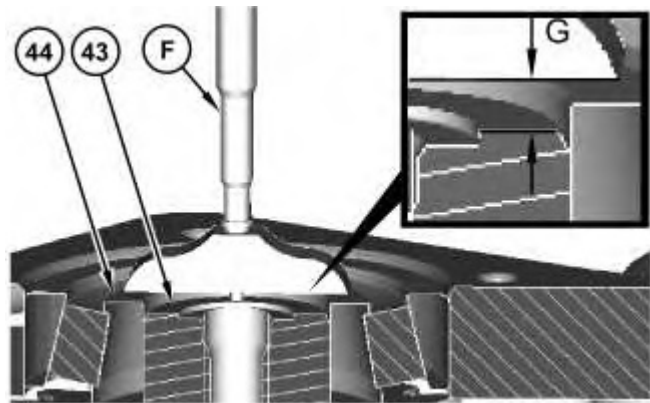

Illustration 14

g02364636

Cutaway view showing Distance (G).

12. Install race (37A). Install bolt (37) and washer (38). Tighten bolt (37) to a torque of 139 N·m (103 lb ft).
13. Remove bolt (37) and washer (38).
14. This step determines the correct shaft preload adjustment for shaft assembly (43). Use Tooling (H) to measure Distance (G). Distance (G) is the measurement from the face of the inner bearing race (44) to the face of shaft assembly (43). The correct shim thickness is determined by subtracting 0.1 mm (0.004 inch) from Distance (G).
15. Apply Tooling (E) to bolt (37). Position shims (39) (not shown), washer (38), and install bolt (37). Tighten bolt (37) to a torque of 139 N·m (103 lb ft).

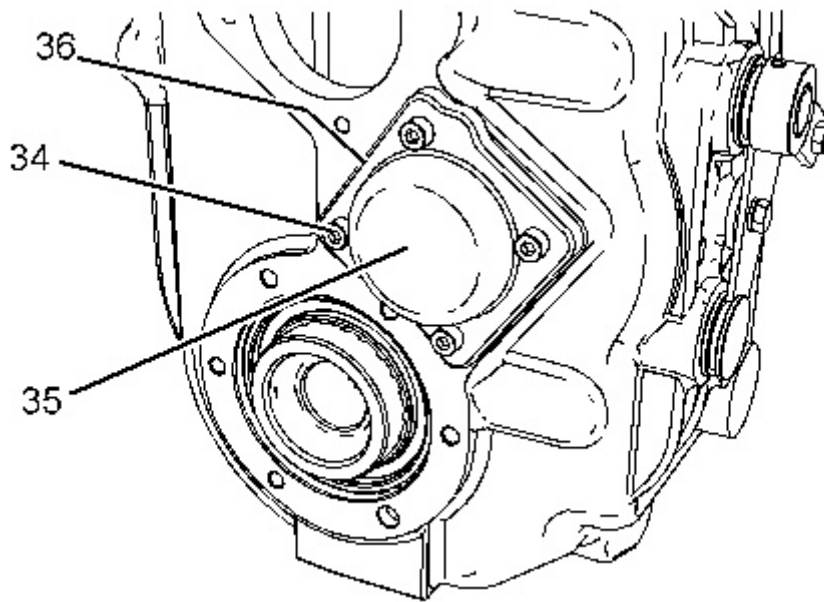

Illustration 15

g02366796

16. Install shims (36) as required to achieve an end play of 0.0508 mm (0.002 inch) on the shaft assembly.
17. Apply Tooling (J) to cover (35). Apply Tooling (M) to bolts (34). Install bolts (34). Tighten bolts (34) to a torque of 23 N·m (16 lb ft).

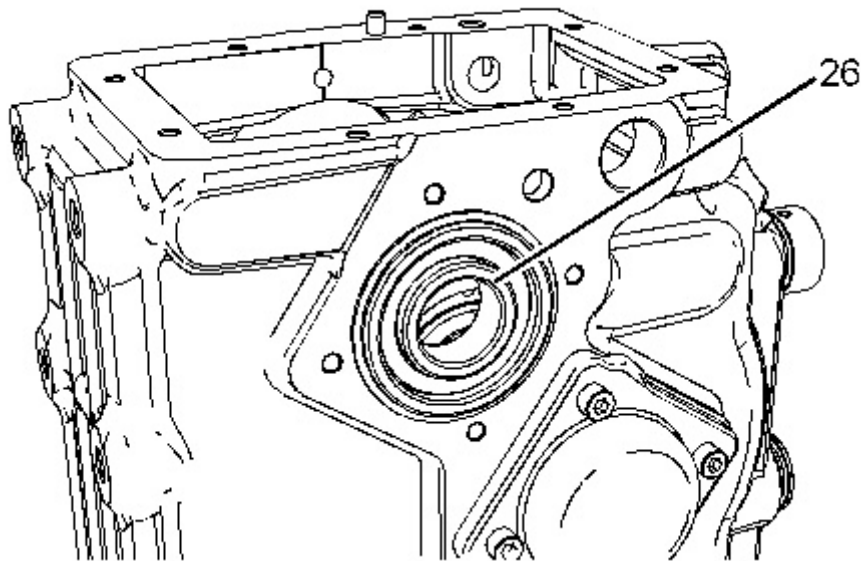

Illustration 16

g01662916

18. Install bearing (26).
-

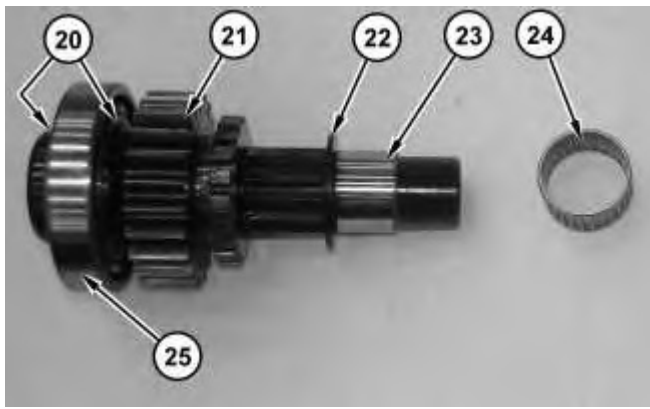

Illustration 17

g01662915

19. Install bearing (25). Install retaining rings (20). Install gear (21). Install washer (22). Install bearing race (23). Install needle bearing (24).

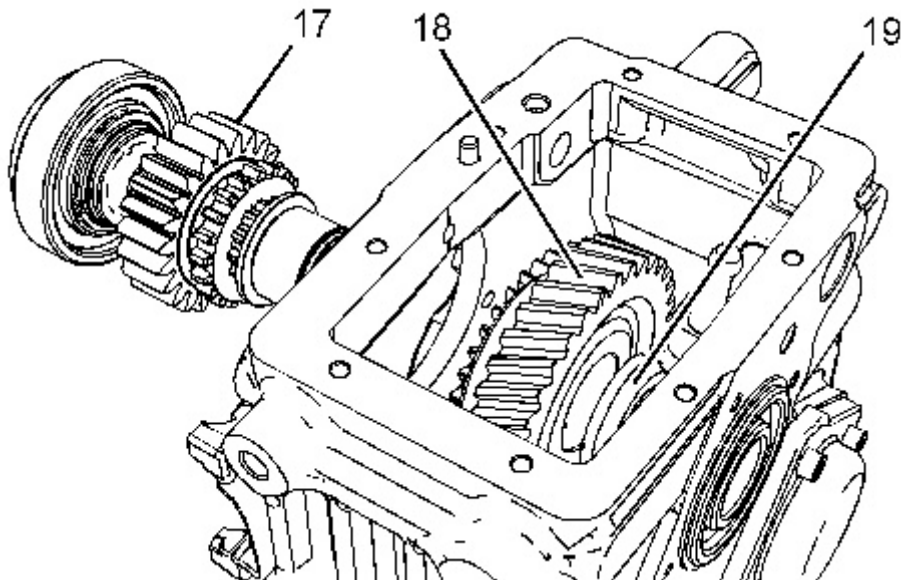

Illustration 18

g01662914

20. Install gear (18) and spacer (19). Install shaft assembly (17).

Thank you so much for reading.
Please click the “Buy Now!”
button below to download the
complete manual.



After you pay.

You can download the most
perfect and complete manual in
the world immediately.

Our support email:

ebooklibonline@outlook.com