

Product: COMPACT WHEEL LOADER

Model: 914K COMPACT WHEEL LOADER L24

Configuration: 914K Compact Wheel Loader L2400001-UP (MACHINE) POWERED BY C4.4 Engine

Disassembly and Assembly C4.4 (Mech) Engines for Caterpillar Built Machines

Media Number -KENR9210-10

Publication Date -01/12/2014

Date Updated -08/08/2018

i02764060

Gear Group (Front) - Remove and Install

SMCS - 1206-010

Removal Procedure

Table 1

Required Tools			
Tool	Part Number	Part Description	Qty
A ⁽¹⁾	9U-6198	Crankshaft Turning Tool	1
A ⁽²⁾	9U-7336	Housing	1
	5P-7305	Engine Turning Tool	1
B	230-6284	Timing Pin (Camshaft)	1
C	230-6283	Timing Pin (Crankshaft)	1

⁽¹⁾ The Crankshaft Turning Tool is used on the front pulley.

⁽²⁾ This Tool is used in the aperture for the electric starting motor.

Start By:

- If the engine is equipped with an air compressor, remove the air compressor. Refer to Disassembly and Assembly, "Air Compressor - Remove and Install".
- If the engine is equipped with a vacuum pump, remove the vacuum pump. Refer to Disassembly and Assembly, "Vacuum Pump - Remove and Install".
- If the engine is equipped with an accessory drive, remove the accessory drive. Refer to Disassembly and Assembly, "Accessory Drive - Remove and Install".
- Remove the front cover. Refer to Disassembly and Assembly, "Front Cover - Remove and Install".

- e. Remove the valve mechanism cover. Refer to Disassembly and Assembly, "Valve Mechanism Cover - Remove and Install".

Note: Either Tooling (A) can be used. Use the Tooling that is most suitable.

NOTICE

Keep all parts clean from contaminants.

Contaminants may cause rapid wear and shortened component life.

NOTICE

Care must be taken to ensure that fluids are contained during performance of inspection, maintenance, testing, adjusting and repair of the product. Be prepared to collect the fluid with suitable containers before opening any compartment or disassembling any component containing fluids.

Dispose of all fluids according to local regulations and mandates.

Note: Care must be taken in order to ensure that the fuel injection pump timing is not lost during the removal of the front gear group. Carefully follow the procedure in order to remove the gear group.

1. Use Tooling (A) in order to rotate the crankshaft so that number one piston is at the top center position on the compression stroke. Refer to Systems Operation, Testing and Adjusting, "Finding Top Centre Position for No.1 Piston".
-

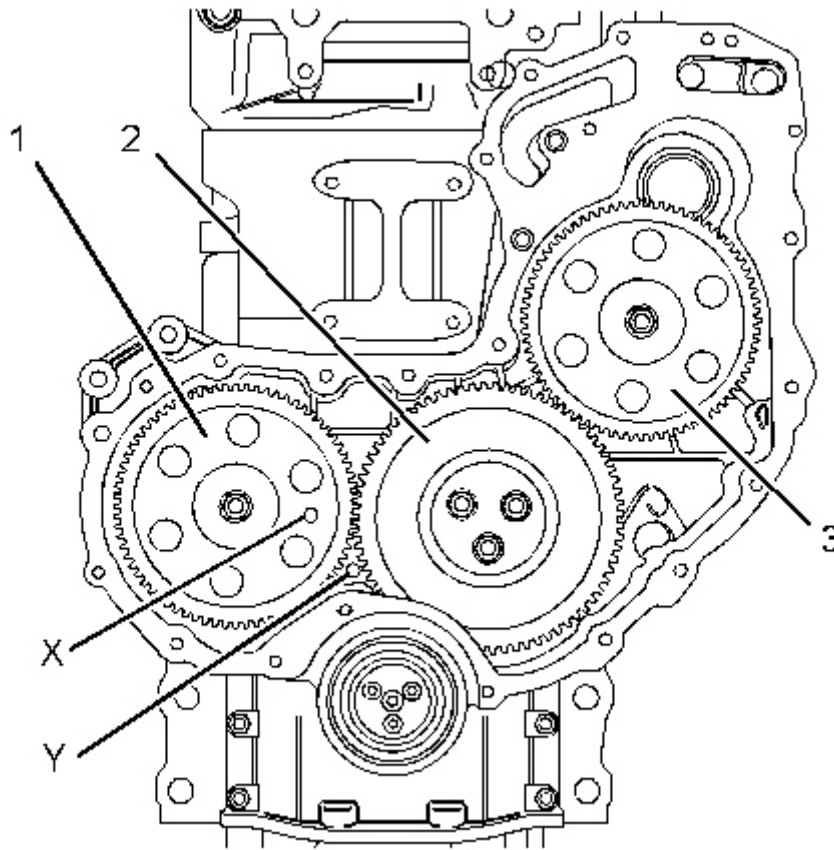

Illustration 1
Typical example

g01247433

2. Install Tooling (B) through hole (X) in camshaft gear (1) into the front housing. Use Tooling (B) in order to lock the camshaft in the correct position. Install Tooling (C) into hole (Y) in the front housing. Use Tooling (C) in order to lock the crankshaft in the correct position. Refer to Systems Operation, Testing and Adjusting, "Finding Top Centre Position for No.1 Piston".

Note: Do not use excessive force to install Tooling (C). Do not use Tooling (C) to hold the crankshaft during repairs.

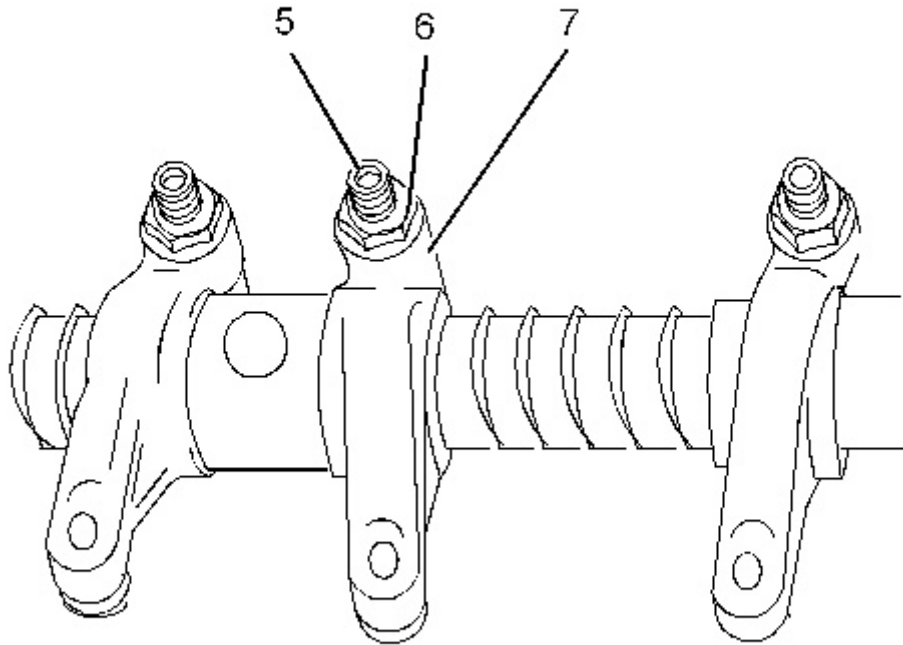

Illustration 2

g01322693

Typical example

3. Loosen nuts (6) on all rocker arms (7). Unscrew adjusters (5) on all rocker arms (7) until all valves are fully closed.

Note: Failure to ensure that ALL adjusters are fully unscrewed can result in contact between the valves and pistons.

4. Apply sufficient pressure to fuel injection pump gear (3) in a counterclockwise direction in order to remove the backlash. Lock the fuel injection pump in this position. Refer to Disassembly and Assembly, "Fuel Pump Gear - Remove" for the correct procedure.
-

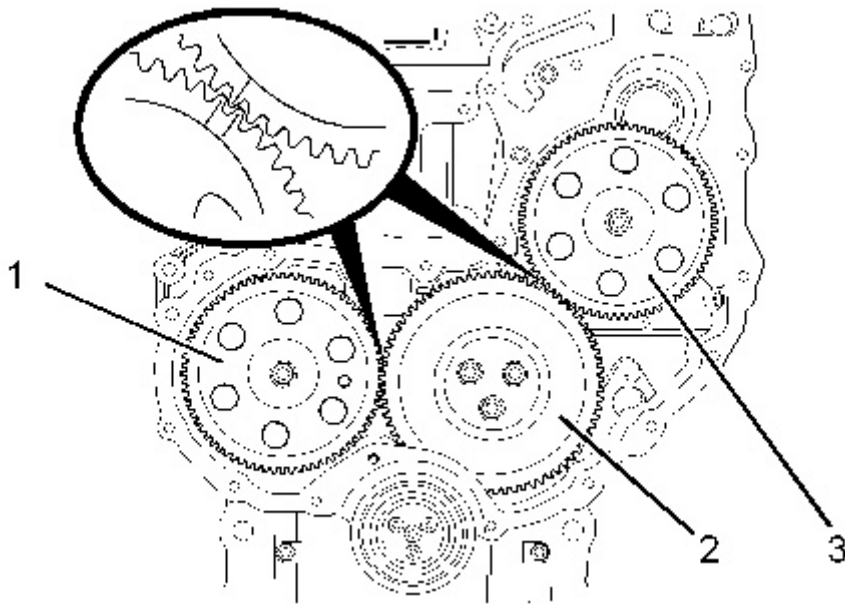

Illustration 3
Typical example

g01335384

5. Mark gears (1), (2) and (3) in order to show alignment. Refer to Illustration 3.

Note: Identification will ensure that the gears can be installed in the original alignment.

6. Remove fuel pump gear (3). Refer to Disassembly and Assembly, "Fuel Pump Gear - Remove" for the correct procedure.
7. Remove camshaft gear (1). Refer to Disassembly and Assembly, "Camshaft Gear - Remove and Install".
8. Remove idler gear (2). Refer to Disassembly and Assembly, "Idler Gear - Remove and Install".

Installation Procedure

Table 2

Required Tools			
Tool	Part Number	Part Description	Qty
B	230-6284	Timing Pin (Camshaft)	1
C	230-6283	Timing Pin (Crankshaft)	1
D	9U-7324	Indicator Bracket	
	7H-1942	Dial Indicator	
	3S-3268	Indicator Contact Point	
	7H-1940	Universal Attachment	

NOTICE

Keep all parts clean from contaminants.

Contaminants may cause rapid wear and shortened component life.

Note: The fuel injection pump must remain locked until the procedure instructs you to unlock the fuel injection pump.

1. Ensure that number one piston is at the top center position on the compression stroke. Refer to Systems Operation, Testing and Adjusting, "Finding Top Center Position for No. 1 Piston".
-

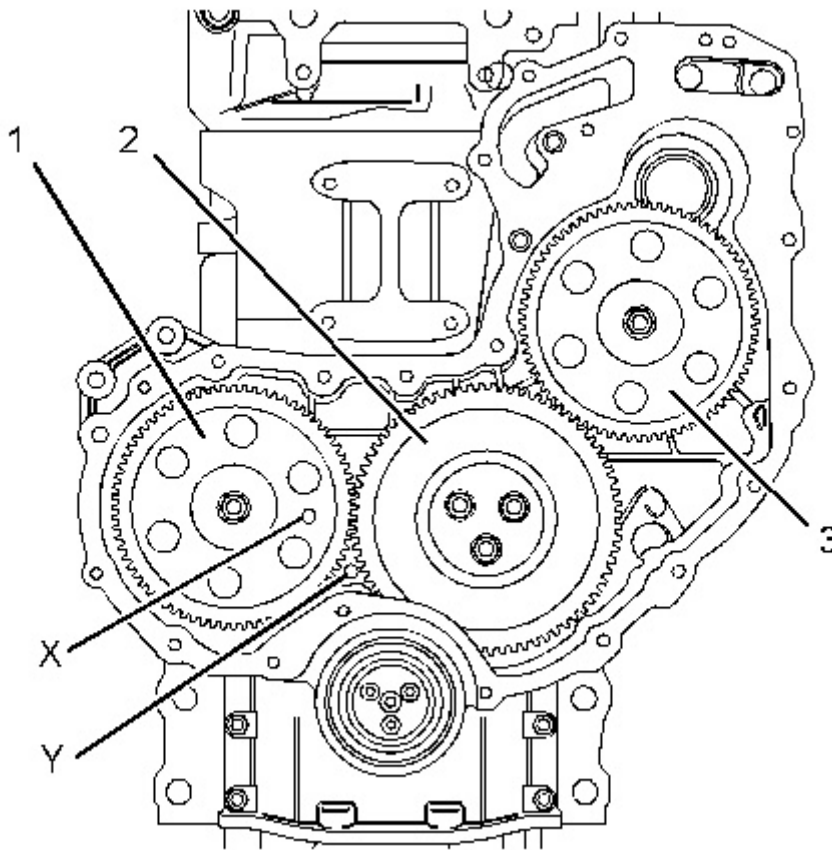

Illustration 4

g01247433

Typical example

2. If necessary, install Tooling (C) into hole (Y) in the front housing. Use Tooling (C) in order to lock the crankshaft in the correct position. Refer to Systems Operation, Testing and Adjusting, "Finding Top Centre Position for No.1 Piston".

Note: Do not use excessive force to install Tooling (C). Do not use Tooling (C) to hold the crankshaft during repairs.

3. Ensure that all of the components of the front gear group are clean and free from wear or damage. If necessary, replace any components that are worn or damaged.

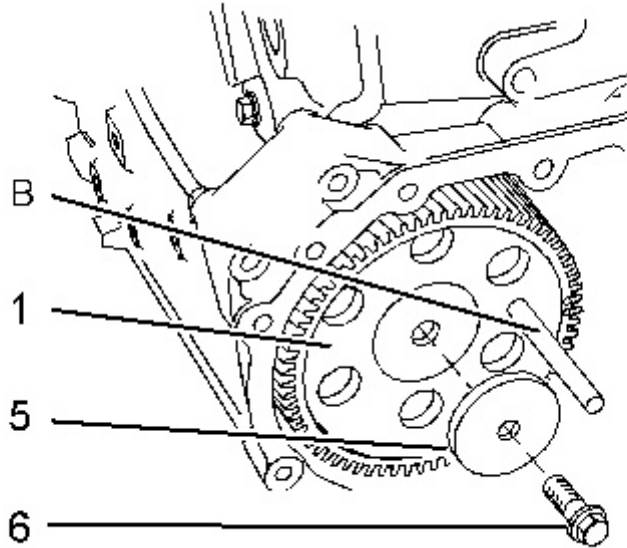

Illustration 5

g01269928

Typical example

4. Install camshaft gear (1). Loosely install bolt (6) and washer (5). Refer to Disassembly and Assembly, "Camshaft Gear - Remove and Install" for more information.
5. Install Tooling (B) through hole (X) in camshaft gear (1) into the front housing.

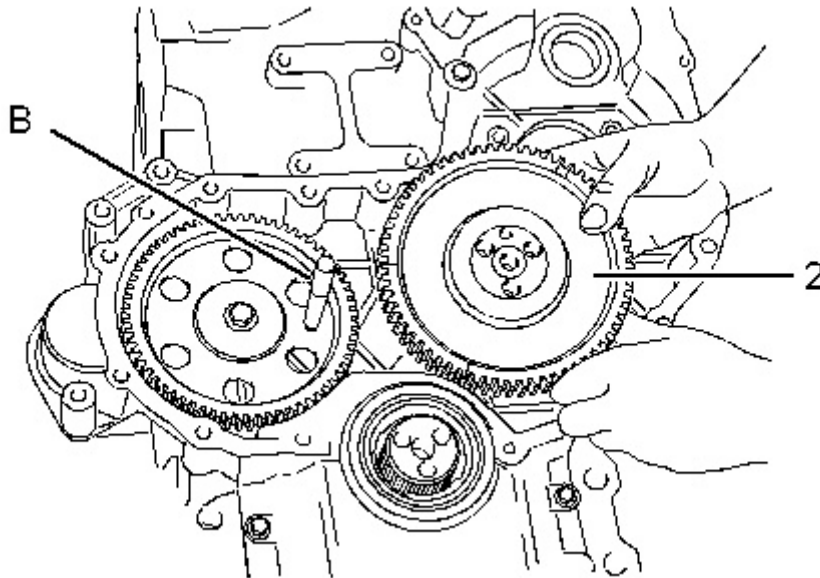

Illustration 6

g01269927

Typical example

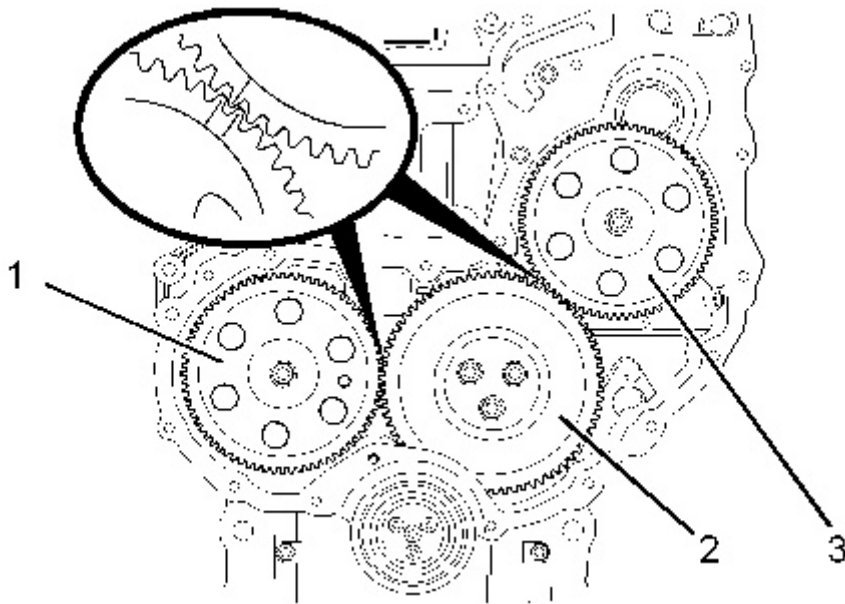

Illustration 7

g01335384

Alignment of timing marks

6. Install idler gear (2). Ensure that the timing marks on gears (1) and (2) are in alignment and that the mesh of the gears is correct. Refer to Disassembly and Assembly, "Idler Gear - Remove and Install". Check the end play of the idler gear. Refer to Specifications, "Gear Group (Front)" and refer to Disassembly and Assembly, "Idler Gear - Remove and Install" for further information.
7. Remove Tooling (B) and (C). Tighten bolt (6) for the camshaft gear to a torque of 95 N·m (70 lb ft). Check the end play of the camshaft gear. Refer to Specifications, "Camshaft" for more information.

Install Tooling (B) through hole (X) in camshaft gear (1) into the front housing and install Tooling (C) into hole (Y) in the front housing.
8. Ensure that the fuel injection pump is locked in the correct position. Refer to Disassembly and Assembly, "Fuel Injection Pump - Install".
9. Install fuel injection pump gear (3). Refer to Disassembly and Assembly, "Fuel Injection Pump Gear - Install" for the correct procedure. Ensure that timing marks on gears (2) and (3) are in alignment. See Illustration 7. Ensure that the mesh of the gears is correct.
10. Remove Tooling (B) and (C).
11. Use Tooling (D) in order to measure the backlash for gears (1), (2) and (3). Ensure that the backlash for the gears is within specified values. Refer to Specifications, "Gear Group (Front)" for further information.
12. Lubricate each gear with clean engine oil.
13. Adjust the engine valve lash. Refer to Systems Operation, Testing and Adjusting, "Engine Valve Lash - Inspect/Adjust".

End By:

- a. Install the front cover. Refer to Disassembly and Assembly, "Front Cover - Remove and Install".
 - b. Install the valve mechanism cover. Refer to Disassembly and Assembly, "Valve Mechanism Cover - Remove and Install".
 - c. If the engine is equipped with an air compressor, install the air compressor. Refer to Disassembly and Assembly, "Air Compressor - Remove and Install".
 - d. If the engine is equipped with a vacuum pump, install the vacuum pump. Refer to Disassembly and Assembly, "Vacuum Pump - Remove and Install".
 - e. If the engine is equipped with an accessory drive, install the accessory drive. Refer to Disassembly and Assembly, "Accessory Drive - Remove and Install".
-

Product: COMPACT WHEEL LOADER

Model: 914K COMPACT WHEEL LOADER L24

Configuration: 914K Compact Wheel Loader L2400001-UP (MACHINE) POWERED BY C4.4 Engine

Disassembly and Assembly C4.4 (Mech) Engines for Caterpillar Built Machines

Media Number -KENR9210-10

Publication Date -01/12/2014

Date Updated -08/08/2018

i02763435

Idler Gear - Remove

SMCS - 1206-011

Removal Procedure (Standard Idler Gear)

Table 1

Required Tools			
Tool	Part Number	Part Description	Qty
A	230-6284	Timing Pin (Camshaft)	1
B	230-6283	Timing Pin (Crankshaft)	1

Start By:

- a. If the engine is equipped with an air compressor, remove the air compressor. Refer to Disassembly and Assembly, "Air Compressor - Remove and Install".
- b. If the engine is equipped with a vacuum pump, remove the vacuum pump. Refer to Disassembly and Assembly, "Vacuum Pump - Remove and Install".
- c. If the engine is equipped with an accessory drive, remove the accessory drive. Refer to Disassembly and Assembly, "Accessory Drive - Remove and Install".
- d. Remove the fuel injection pump gear. Refer to Disassembly and Assembly, "Fuel Pump Gear - Remove".
- e. Remove the valve mechanism cover. Refer to Disassembly and Assembly, "Valve Mechanism Cover - Remove and Install".

Note: Care must be taken in order to ensure that the fuel injection pump timing is not lost during the removal of the fuel pump gear. Carefully follow the procedure in order to remove the fuel pump gear.

NOTICE

Keep all parts clean from contaminants.

Contaminants may cause rapid wear and shortened component life.

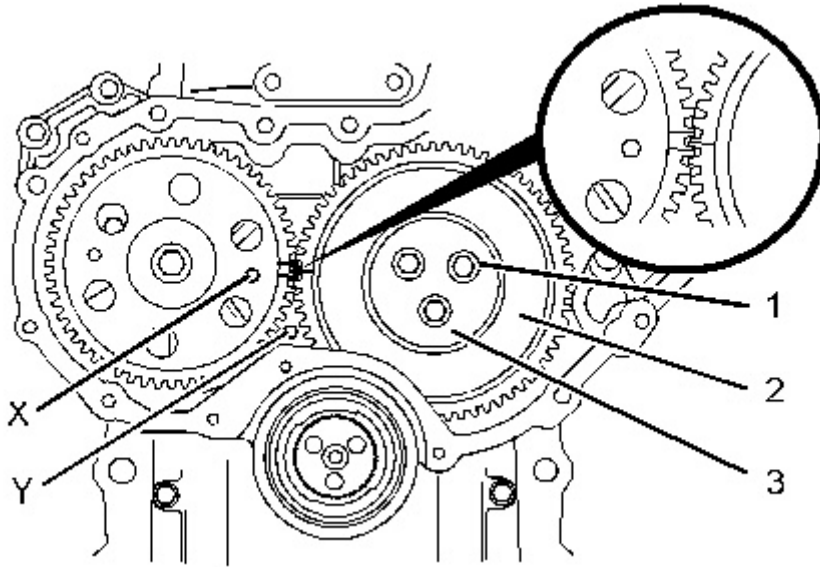

Illustration 1

g01343975

Alignment of timing marks

1. Ensure that Tooling (A) is installed into hole (X) in the camshaft gear. Use Tooling (A) in order to lock the camshaft in the correct position.
Note: Ensure that the gears are marked in order to show alignment. Refer to Illustration 1.
 2. Ensure that Tooling (B) is installed in hole (Y) in the front housing. Use Tooling (B) in order to lock the crankshaft in the correct position.
-

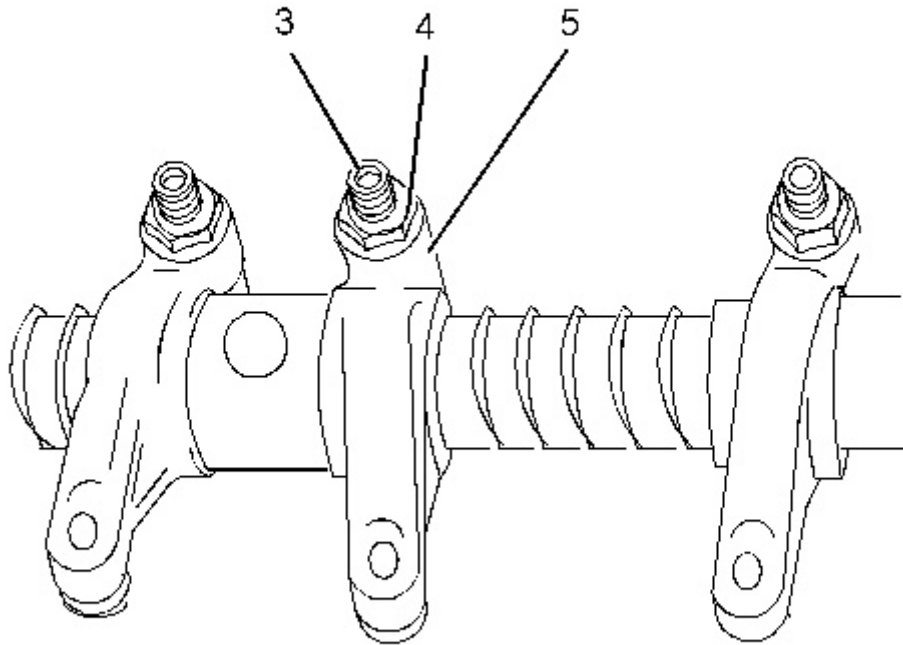

Illustration 2

g01348926

Typical example

3. Loosen nuts (4) on all rocker arms (5). Unscrew adjusters (3) on all rocker arms (5) until all valves are fully closed.

Note: Failure to ensure that ALL adjusters are fully unscrewed can result in contact between the valves and pistons.

4. Mark plate (3) in order to show orientation. Refer to Illustration 1.

Note: Identification will ensure that the plate can be installed in the original orientation.

5. Remove bolts (1). Refer to Illustration 1.
 6. Remove plate (3).
-

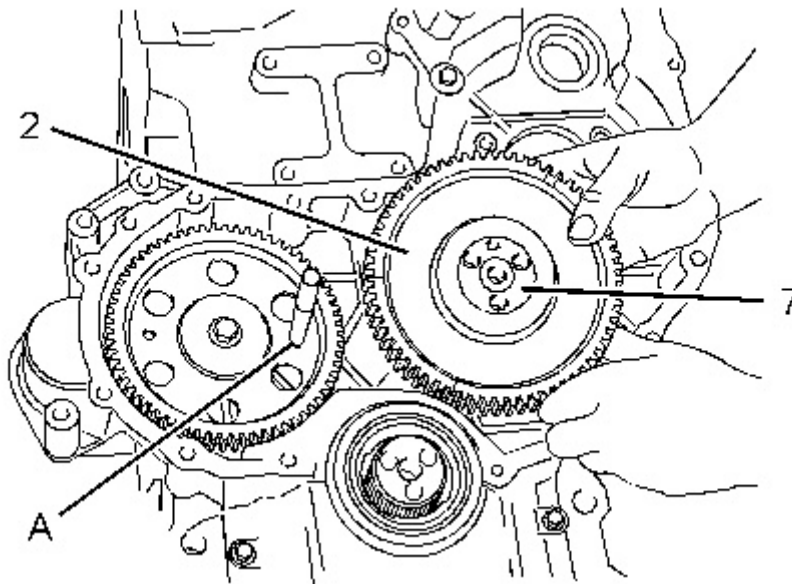

Illustration 3
Typical example

g01269930

7. Remove the assembly of idler gear (2) and hub (7) from the recess in the front housing.

Note: The idler gear must be tilted during removal.

8. Remove hub (7) from idler gear (2).

Removal Procedure (Heavy-Duty Idler Gear)

Table 2

Required Tools			
Tool	Part Number	Part Description	Qty
A	230-6284	Timing Pin (Camshaft)	1
B	230-6283	Timing Pin (Crankshaft)	1
C	-	Bolt (M8x80mm)	1

Start By:

- a. If the engine is equipped with an air compressor, remove the air compressor. Refer to Disassembly and Assembly, "Air Compressor - Remove and Install".
- b. If the engine is equipped with a vacuum pump, remove the vacuum pump. Refer to Disassembly and Assembly, "Vacuum Pump - Remove and Install".
- c. If the engine is equipped with an accessory drive, remove the accessory drive. Refer to Disassembly and Assembly, "Accessory Drive - Remove and Install".

- d. Remove the fuel injection pump gear. Refer to Disassembly and Assembly, "Fuel Pump Gear - Remove".
- e. Remove the valve mechanism cover. Refer to Disassembly and Assembly, "Valve Mechanism Cover - Remove and Install".

Note: Care must be taken in order to ensure that the fuel injection pump timing is not lost during the removal of the fuel pump gear. Carefully follow the procedure in order to remove the fuel pump gear.

NOTICE

Keep all parts clean from contaminants.

Contaminants may cause rapid wear and shortened component life.

Note: The assembly of heavy-duty idler gear is not serviceable. Do not disassemble the heavy-duty idler gear.

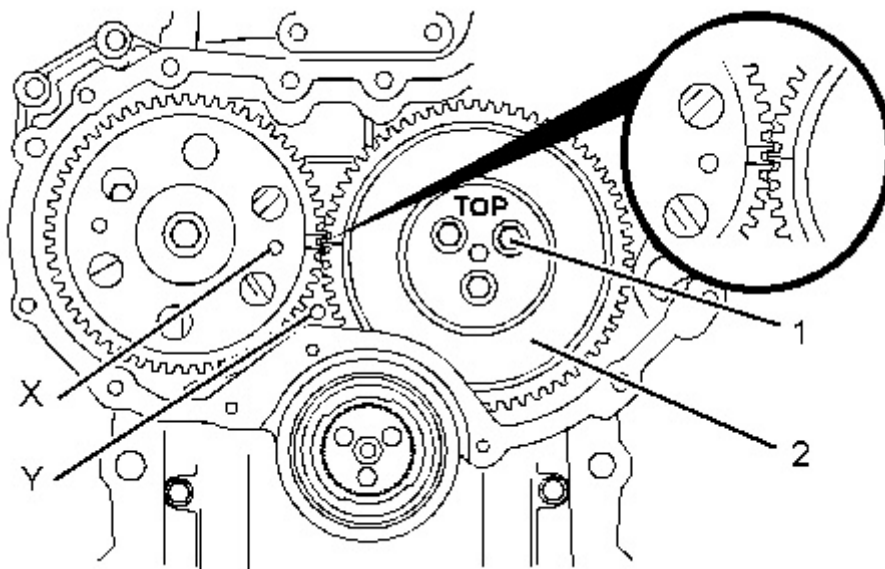

Illustration 4

g01343977

Alignment of timing marks

1. Ensure that Tooling (A) is installed into hole (X) in the camshaft gear. Use Tooling (A) in order to lock the camshaft in the correct position.

Note: Ensure that the gears are marked in order to show alignment. Refer to Illustration 4.

2. Ensure that Tooling (B) is installed in hole (Y) in the front housing. Use Tooling (B) in order to lock the crankshaft in the correct position.
-

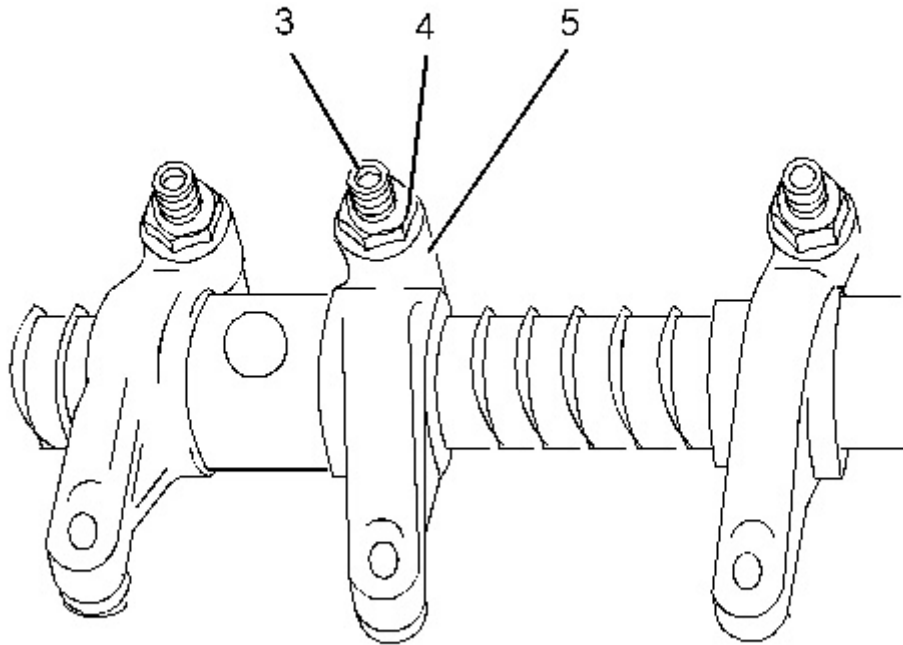

Illustration 5
Typical example

g01348930

3. Loosen nuts (4) on all rocker arms (5). Unscrew adjusters (3) on all rocker arms (5) until all valves are fully closed.

Note: Failure to ensure that ALL adjusters are fully unscrewed can result in contact between the valves and pistons.

4. Remove bolts (1) from the assembly of heavy-duty idler gear (2). Refer to Illustration 4.
-

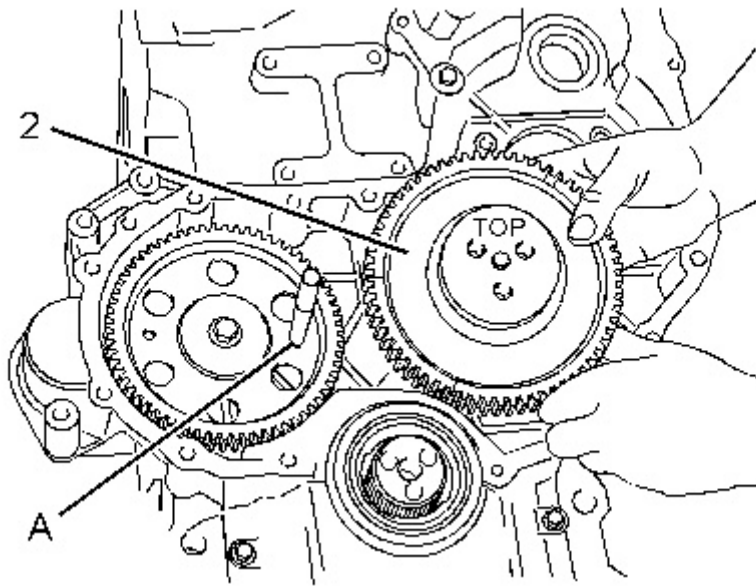
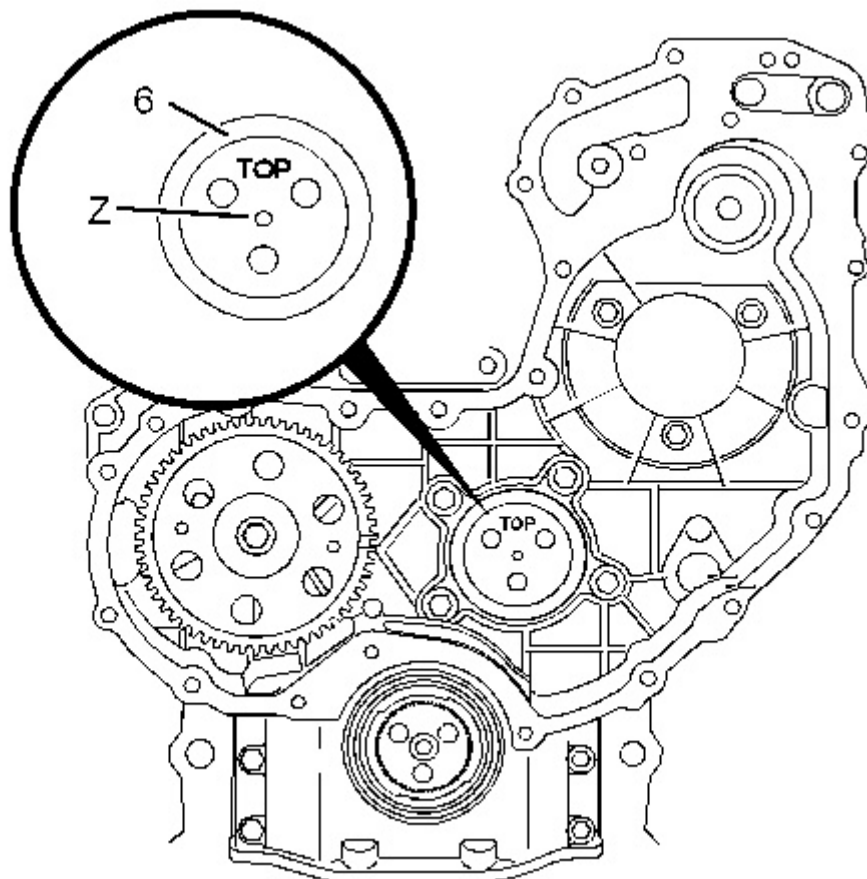

Illustration 6
Typical example

g01269933

5. Remove the assembly of idler gear (2) from the recess in the front housing.

Note: The idler gear must be tilted during removal.



Typical example

6. If necessary, remove plate (6). Install Tooling (C) into threaded hole (Z) in order to remove plate (6).
-

Product: COMPACT WHEEL LOADER

Model: 914K COMPACT WHEEL LOADER L24

Configuration: 914K Compact Wheel Loader L2400001-UP (MACHINE) POWERED BY C4.4 Engine

Disassembly and Assembly C4.4 (Mech) Engines for Caterpillar Built Machines

Media Number -KENR9210-10

Publication Date -01/12/2014

Date Updated -08/08/2018

i02763436

Idler Gear - Install

SMCS - 1206-012

Installation Procedure (Standard Idler Gear)

Table 1

Required Tools			
Tool	Part Number	Part Description	Qty
A	230-6284	Timing Pin (Camshaft)	1
B	230-6283	Timing Pin (Crankshaft)	1
C	9U-7324	Indicator Bracket	1
	7H-1942	Dial Indicator	1
	3S-3268	Indicator Contact Point	1
	7H-1940	Universal Attachment	1

NOTICE

Keep all parts clean from contaminants.

Contaminants may cause rapid wear and shortened component life.

1. Ensure that number one piston is at the top center position on the compression stroke. Refer to the Systems Operation, Testing and Adjusting, "Finding Top Center Position for No. 1 Piston".
-

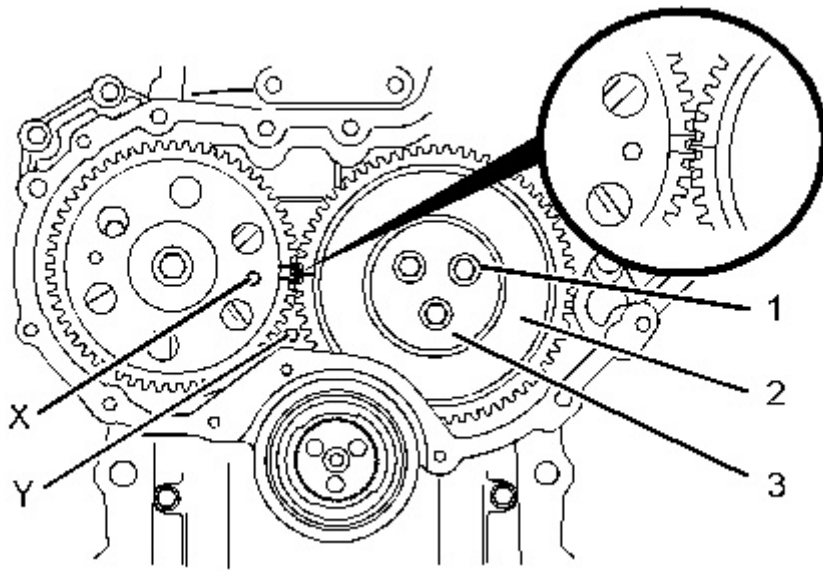

Illustration 1

g01343975

Alignment of timing marks

2. Ensure that Tooling (A) is installed into hole (X) in camshaft gear (1).
3. Ensure that Tooling (B) is installed in hole (Y) in the front housing. Use Tooling (B) in order to lock the crankshaft in the correct position. Refer to Systems Operation, Testing and Adjusting, "Finding Top Centre Position for No.1 Piston".

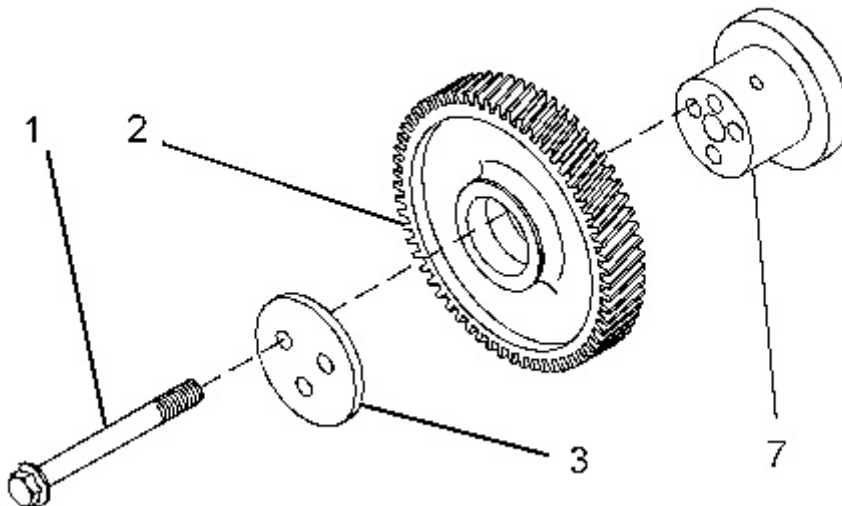

Illustration 2

g01269934

4. Clean idler gear (2) and inspect the idler gear for wear or damage. Refer to Specifications, "Gear Group (Front)" for more information. If necessary, replace the idler gear.
5. Clean hub (7) and inspect the hub for wear or damage. Refer to Specifications, "Gear Group (Front)" for more information. If necessary, replace the hub.

- Lubricate hub (7) with clean engine oil. Slide the hub into idler gear (2). Ensure that the timing marks are toward the front of the idler gear.
-

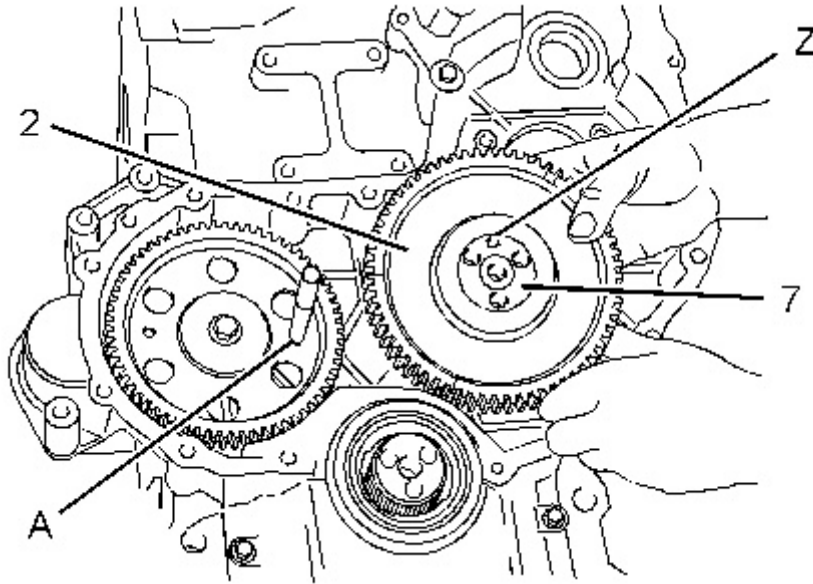

Illustration 3

g01269935

Typical example

- Align the timing mark on idler gear (2) with the timing mark on the camshaft gear. Refer to the Illustration 1. Install the assembly of idler gear (2) and hub (7) into the recess in the timing case. Ensure that oil hole (Z) is to the top of the hub.
- Note:** The idler gear must be tilted during installation. Ensure that the holes in the hub are aligned with the holes in the cylinder block.
- Clean plate (3) and inspect the plate for wear or damage. If necessary, replace the plate.
 - Lubricate plate (3) with clean engine oil. A used plate should be installed in the original orientation. If a new plate is installed, ensure that the holes in plate (3) are aligned with the holes in hub (7). Install plate (3) to hub (7).
 - Install bolts (1). Tighten bolts (1) to a torque of 44 N·m (32 lb ft).
-

Thank you so much for reading.
Please click the “Buy Now!”
button below to download the
complete manual.



After you pay.

You can download the most
perfect and complete manual in
the world immediately.

Our support email:

ebooklibonline@outlook.com