

Product: WHEEL LOADER

Model: 928G WHEEL LOADER DJD

Configuration: 928G Wheel Loader IT28G Integrated Toolcarrier DJD00001-02977 (MACHINE) POWERED BY 3056E Engine

## Disassembly and Assembly

### IT28G Integrated Toolcarrier and 924G, 924GZ and 928G Wheel Loaders Power Train

Media Number -REN6422-07

Publication Date -01/10/2017

Date Updated -09/10/2017

i02247494

## Transmission and Torque Converter - Disassemble

SMCS - 3001-015

### Disassembly Procedure

Table 1

Required Tools			
Tool	Part Number	Part Description	Qty
A	1P-2420	Transmission Repair Stand	1
B	180-3033	Repair Stand Set	1
C	138-7574	Link Bracket	2
D	4C-6136	Lifting Bracket	1
E	4C-6399	Compressor Assembly (Clutch Spring)	1
F	FT-2343	Plexiglass Cover	1
G	1P-2321	Combination Puller	1
H	4C-3652	Compressor Assembly (Clutch Spring)	1

#### Start By:

- Remove the transmission. Refer to Disassembly and Assembly, "Transmission and Torque Converter - Remove".

**Note:** Cleanliness is an important factor. Before you begin the disassembly procedure, the exterior of the components should be thoroughly cleaned. This will help to prevent dirt from entering the internal mechanism.

---

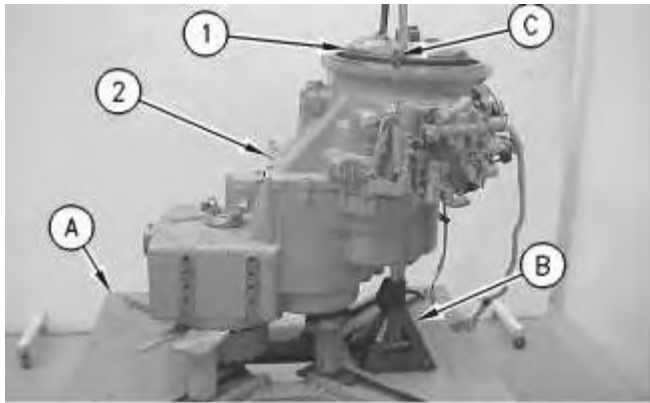

Illustration 1

g00653680

1. Use Tooling (C) and a suitable lifting device in order to position transmission (2) on Tooling (A) and (B), as shown. The weight of transmission (2) is approximately 500 kg (1100 lb).
2. Remove torque converter (1).



Illustration 2

g00671890

3. Remove bolts (3) and flex plate (4) from torque converter (1).

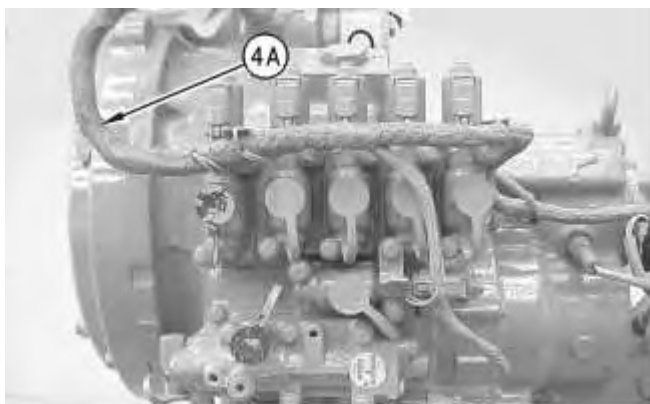

Illustration 3

g01005185

4. Disconnect harness assembly (4A) from the valve assembly.

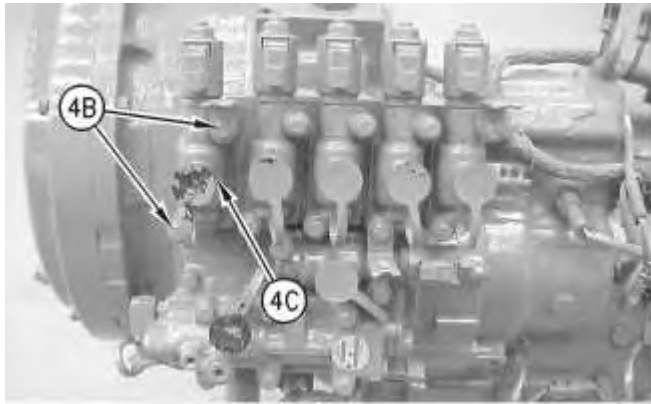

Illustration 4

g01005186

**Note:** Mark each valve group for installation purposes.

5. Remove bolts (4B) and remove valve assembly (4C).
6. Repeat Step 5 for the remaining valve assemblies.

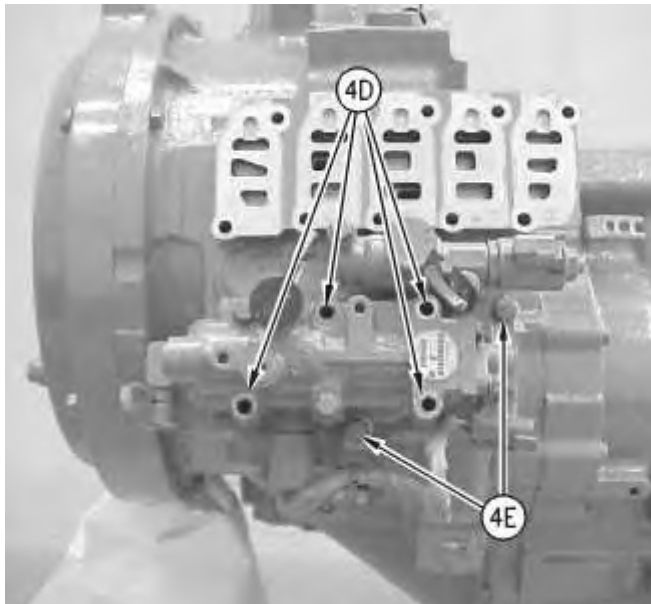

Illustration 5

g01005187

7. Remove bolts (4D) from the relief valve. Remove bolts (4E) and remove the manifold assembly.
-



Illustration 6

g00653775

8. Remove bolts (5) and plate (6).



Illustration 7

g00653801

9. Remove lip seal (7) and seal (8).

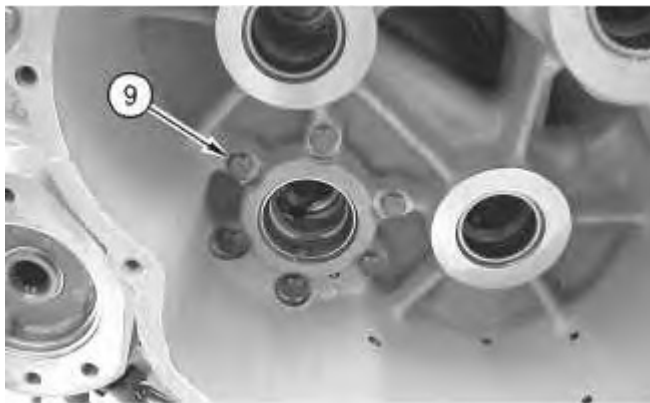

Illustration 8

g00653806

10. Remove bolts (9).



Illustration 9

g00653808

11. Remove gear assembly (10).
12. Remove O-ring seals (11).



Illustration 10

g00653825

13. Remove bolts (12) and gear (13).

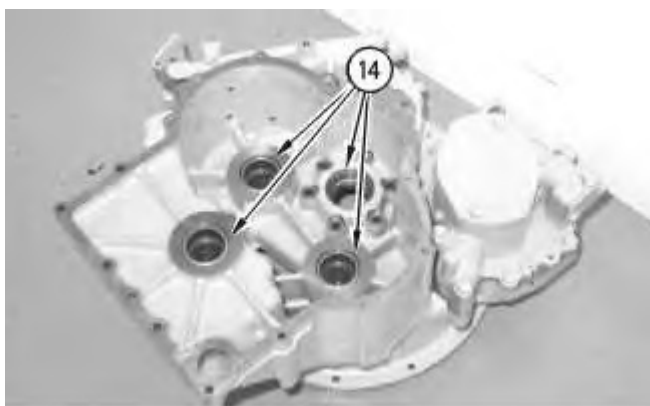

Illustration 11

g00653848

14. Remove bearing cups (14).

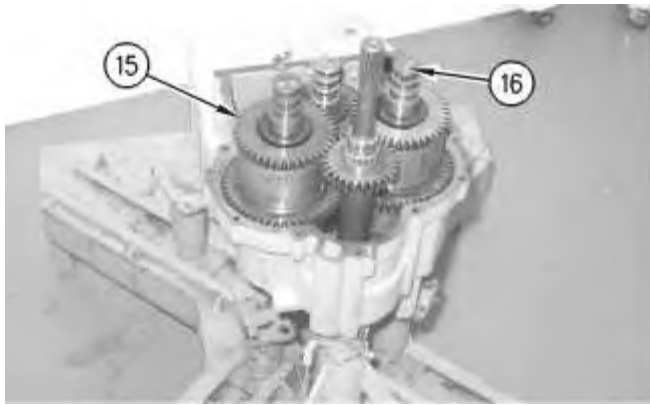

Illustration 12

g00653858

- Using Tooling (D) to remove the forward low and the forward high clutch group (15). The weight of the forward low and the forward high clutch group (15) is approximately 27 kg (60 lb).

**Note:** When the clutch groups are disassembled, remove shaft plugs (16) in order to clean the oil passages. Use a punch to drive the plug into the shaft. Drill the remainder of the aluminum plug out of the bore. Be careful not to drill any portion of the walls of the bore. Use shop air or a cleaning solution in order to clean the shafts.

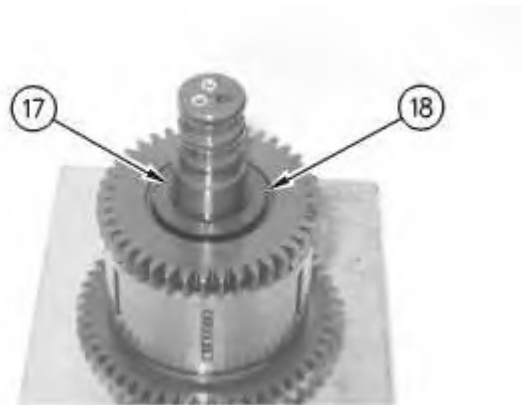

Illustration 13

g00653893

- Remove retaining ring (17) and washer (18).



17. Remove retaining ring (19).
18. Use a suitable press in order to remove gear (20).



19. Remove retaining ring (22). Remove hub (21). Remove plates and discs (23).

**Note:** Take note of the number and order of plates and discs for assembly purposes.



20. Remove washer (24).

**Note:** The retainer may stick to the inside of hub (21) when the hub is removed.

---

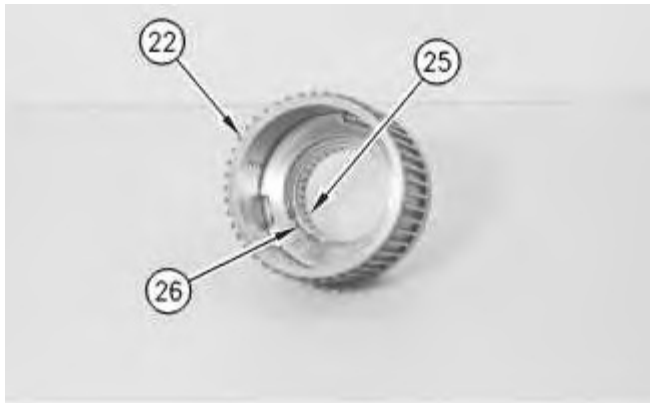

Illustration 17

g00890608

21. Remove retaining ring (26). Press bearing (25) from hub (22).

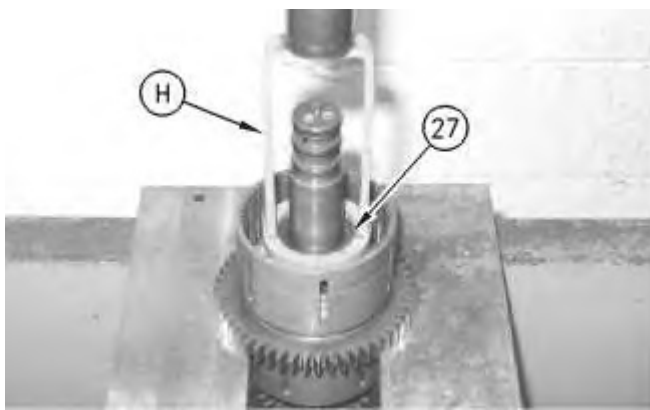

Illustration 18

g00654018



**Personal injury can result from being struck by parts propelled by a released spring force.**

**Make sure to wear all necessary protective equipment.**

**Follow the recommended procedure and use all recommended tooling to release the spring force.**

22. Put the forward low clutch group in a suitable press. Use Tooling (H) in order to compress the spring. Remove retaining ring (27).





Illustration 19

g00654029

23. Remove retainer (28) and spring (29).

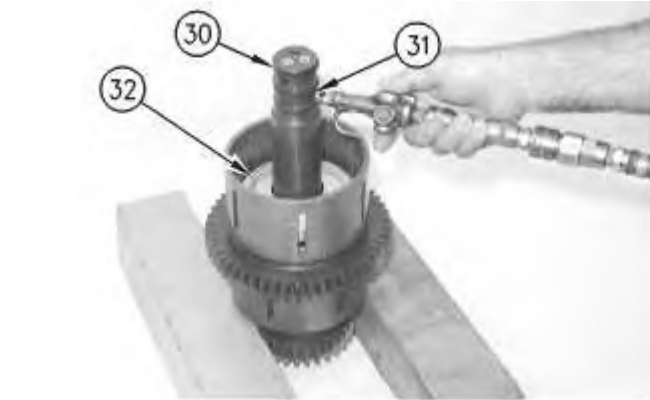

Illustration 20

g00890609

24. Blow shop air 276 kPa to 414 kPa (40 psi to 60 psi) into lube passage (31) in order to remove piston (32).
25. Remove seals (30).



Illustration 21

g00654063

26. Remove O-ring seals (33).

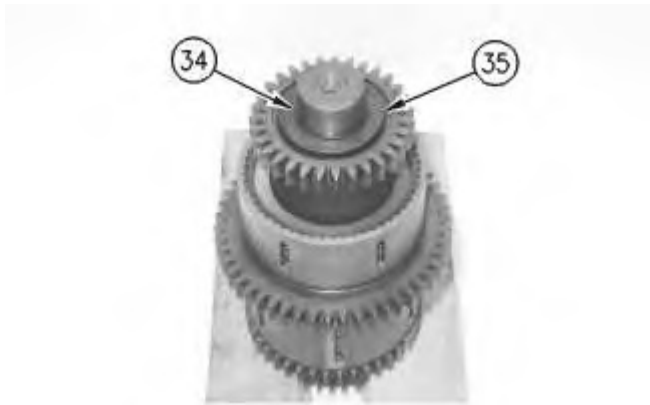

---

Illustration 22

g00654078

27. Disassemble the forward high clutch group by removing retaining ring (34). Remove washer (35).



---

Illustration 23

g00654253

28. Remove ring (36). Remove gear (37).

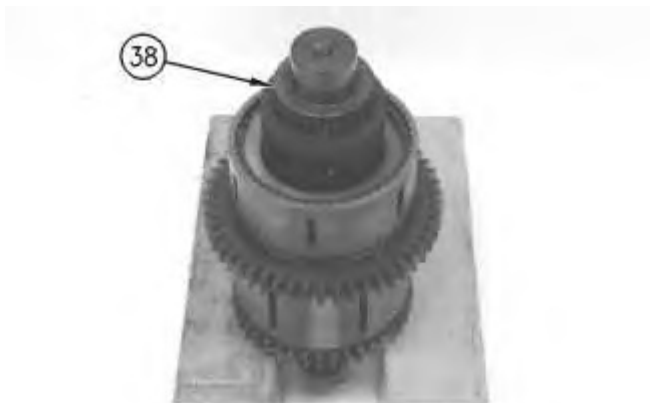

---

Illustration 24

g00654261

29. Remove hub (38).
-

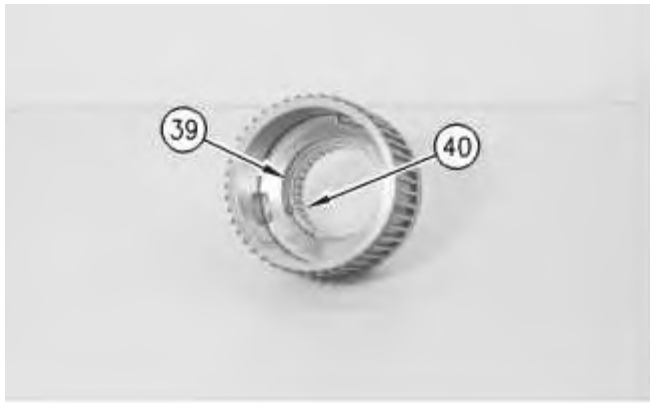

Illustration 25

g00654263

30. Remove retaining ring (39). Use a suitable press in order to remove bearing (40).

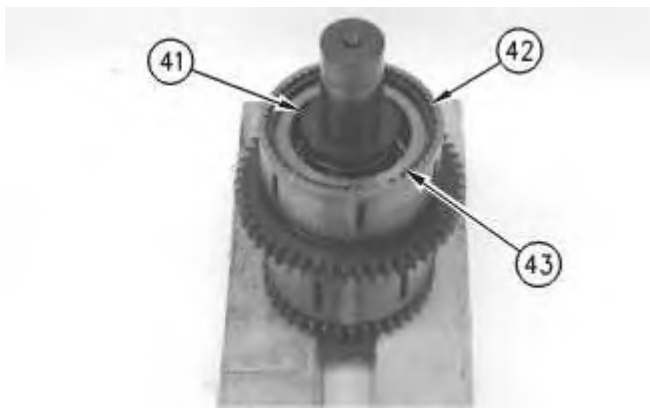

Illustration 26

g00654274

31. Remove washer (41). Remove retaining ring (42). Remove the plate and discs (43).

**Note:** Take note of the number and order of plates and discs for assembly purposes.

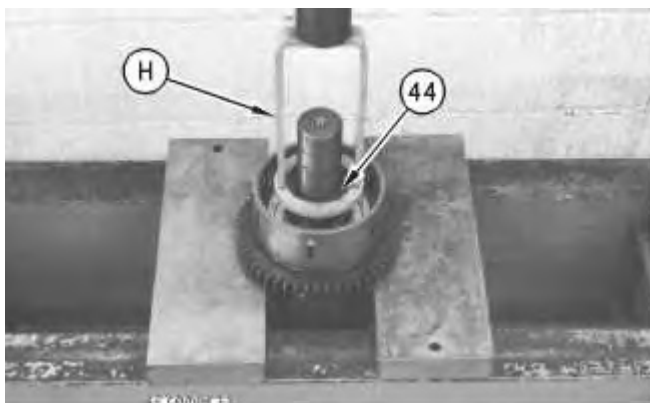

Illustration 27

g00654276

## **WARNING**

**Personal injury can result from being struck by parts propelled by a released spring force.**

**Make sure to wear all necessary protective equipment.**

**Follow the recommended procedure and use all recommended tooling to release the spring force.**

---

32. Put the forward high clutch group in a suitable press. Use Tooling (H) in order to remove retaining ring (44).
- 

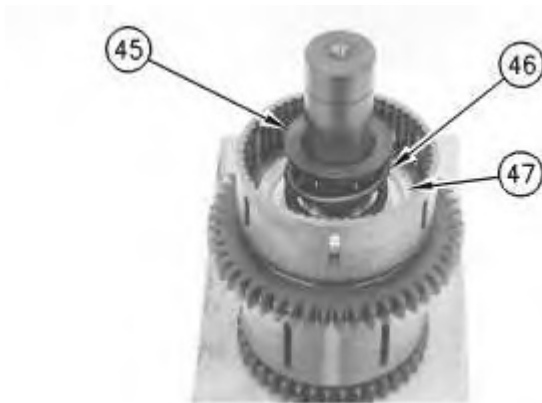

Illustration 28

g00654280

---



Illustration 29

g00654282

---

33. Remove retainer (45) and spring (46).
34. Blow shop air 276 kPa to 414 kPa (40 psi to 60 psi) into lube passage (48) in order to remove piston (47).
-

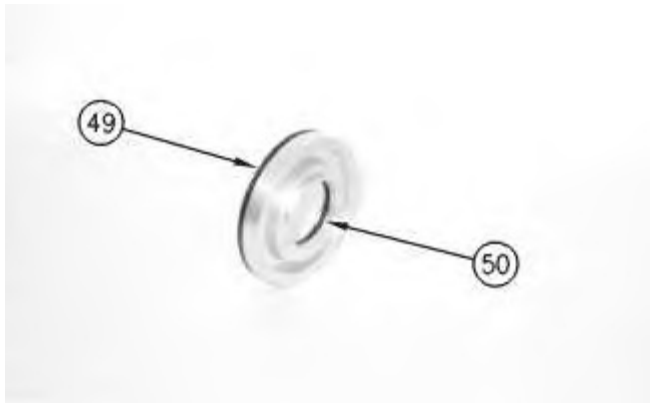

Illustration 30

g00654292

35. Remove O-ring seals (49) and (50).

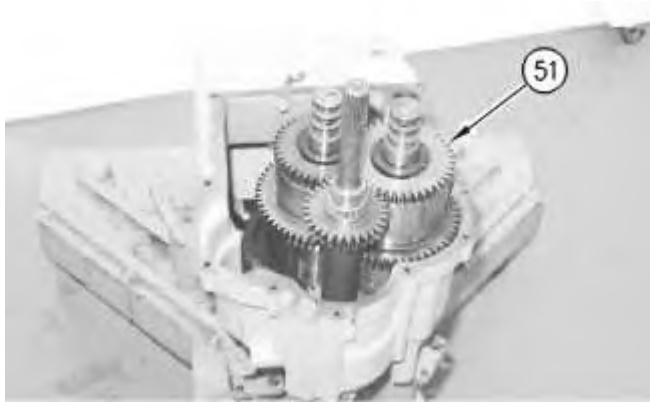

Illustration 31

g00654301

36. Use Tooling (D) in order to remove reverse second gear clutch group (51). The weight of reverse second gear clutch group (51) is approximately 32 kg (70 lb).



Illustration 32

g00654339

37. Remove retaining ring (52) and washer (53).

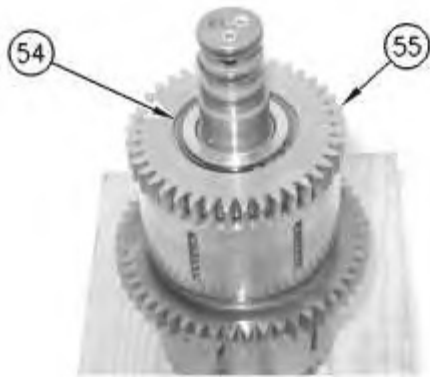

Illustration 33

g00654328

38. Remove retaining ring (54) and gear (55).

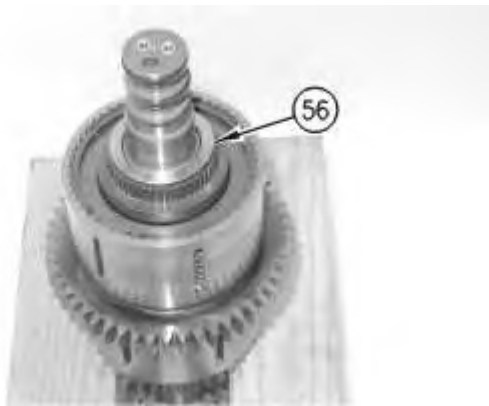

Illustration 34

g00654347

39. Remove hub assembly (56).



Illustration 35

g00890610

40. Remove washer (58).
41. Remove retaining ring (57). Remove plates and discs (59).

**Note:** Take note of the number and order of the plates and discs for assembly purposes.

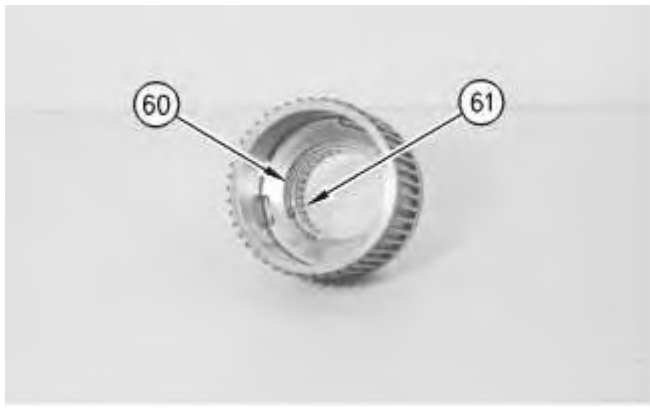

Illustration 36

g00890611

42. Remove retaining ring (60). Use a suitable press in order to remove bearing (61).

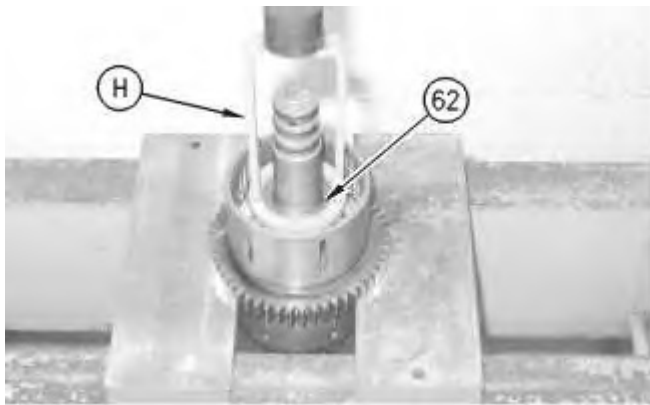

Illustration 37

g00654360



**Personal injury can result from being struck by parts propelled by a released spring force.**

**Make sure to wear all necessary protective equipment.**

**Follow the recommended procedure and use all recommended tooling to release the spring force.**

- 
43. Put the reverse clutch group in a suitable press. Use Tooling (H) in order to remove retaining ring (62).
-

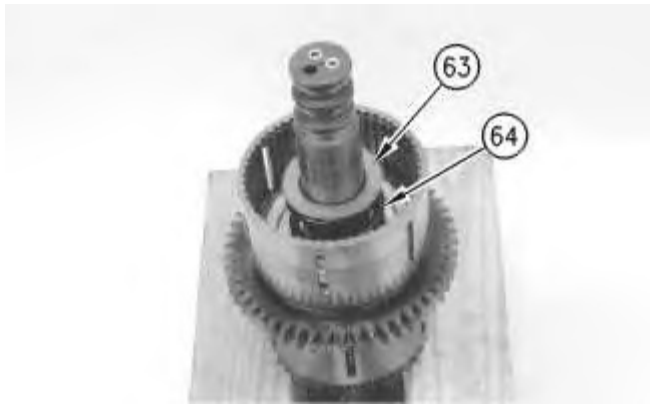

Illustration 38

g00654364

44. Remove retainer (63) and spring (64).



Illustration 39

g00654372

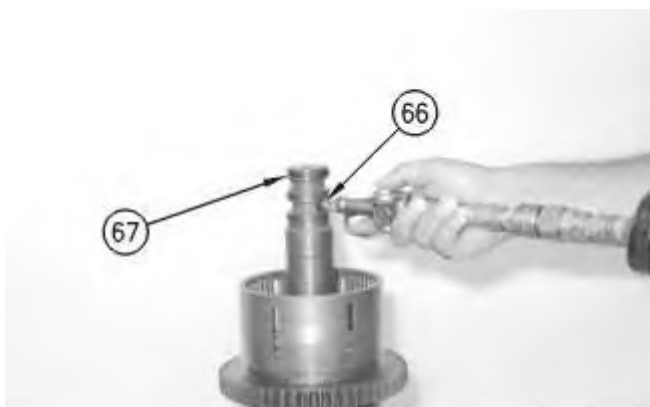

Illustration 40

g00654378

45. Blow shop air 276 kPa to 414 kPa (40 psi to 60 psi) into lube passage (66) in order to remove piston (65).
46. Remove seals (67).





Illustration 41

g00654403

47. Remove O-ring seals (68) and (69).

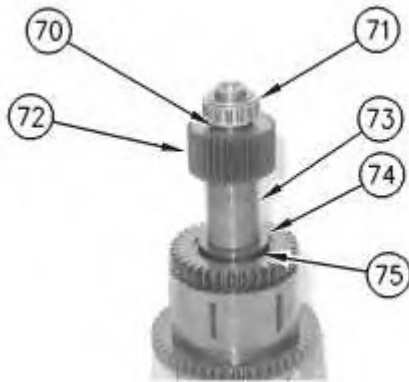

Illustration 42

g00890612

48. Install a suitable puller under gear (72). Pull gear (72), spacer (70), and bearing cone (71).  
49. Remove spacer (73). Remove washer (74) and (75).

**Note:** Use Steps 38 through 47 for the remaining disassembly of the second gear clutch group. In Step 43, use Tooling (E) instead of Tooling (H).

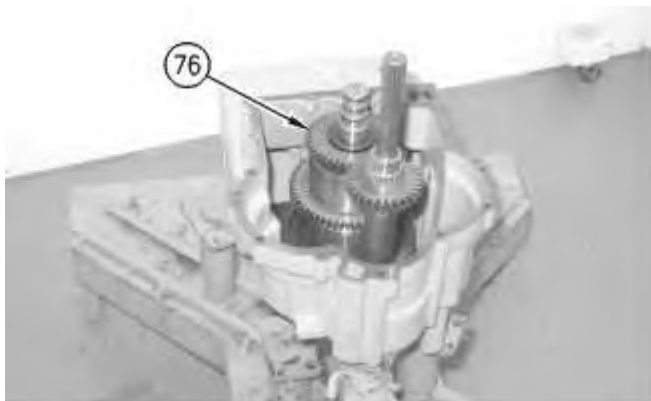

Illustration 43

g00654494

50. Use Tooling (D) in order to remove first third gear clutch group (76). The weight of first third gear clutch group (76) is approximately 50 kg (110 lb).



---

Illustration 44

g00654497

51. Remove retaining ring (77) and washer (78).



---

Illustration 45

g00654507

52. Remove retaining ring (79) and gear (80).



---

Illustration 46

g00654512

53. Remove hub assembly (81).



Illustration 47

g00890613

54. Remove retaining ring (82). Use a suitable press in order to remove bearing (83).



Illustration 48

g00654519

55. Remove washer (84).
56. Remove retaining ring (85). Remove plates and discs (86).

**Note:** Take note of the number and order of the plates and discs for assembly purposes.



Illustration 49

g00654525

## **WARNING**

**Personal injury can result from being struck by parts propelled by a released spring force.**

**Make sure to wear all necessary protective equipment.**

**Follow the recommended procedure and use all recommended tooling to release the spring force.**

---

57. Put the third gear clutch group in a suitable press. Use Tooling (H) in order to remove ring (87).



Illustration 50

g00654534

58. Remove retainer (88) and spring (89).



Illustration 51

g00890615

59. Blow shop air 276 kPa to 414 kPa (40 psi to 60 psi) into lube passage (91) in order to remove piston (90).
60. Remove seals (92).



Illustration 52

g00654638

61. Remove O-ring seals (93) and (94).

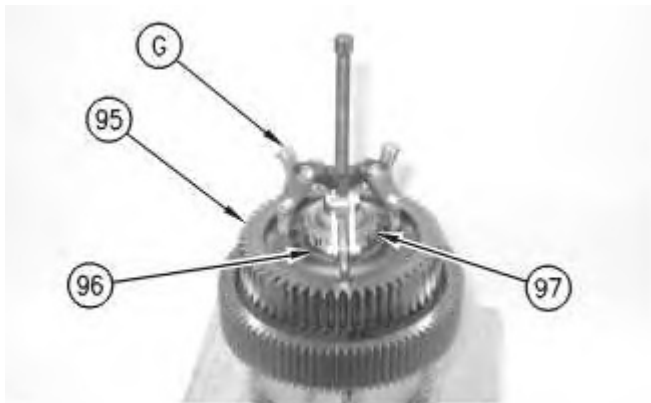

Illustration 53

g00890617

62. Disassemble the first gear clutch by installing Tooling (G) through the holes in gear (95). Pull gear (95), washer (96), and bearing (97) together.

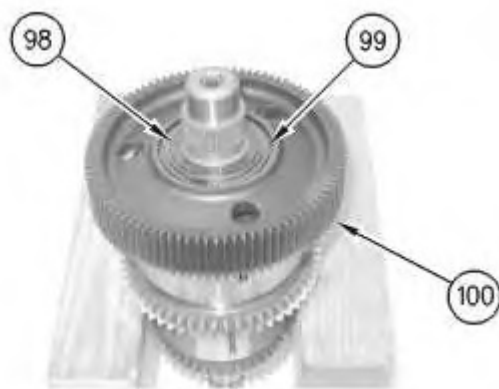

Illustration 54

g00654719

63. Remove washer (98). Remove retaining ring (99) and gear (100).
-

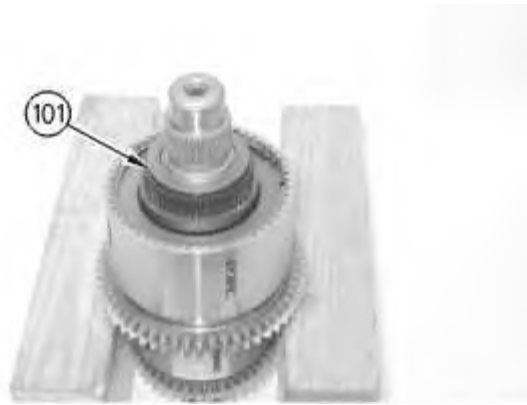

Illustration 55

g00654724

64. Remove hub assembly (101).

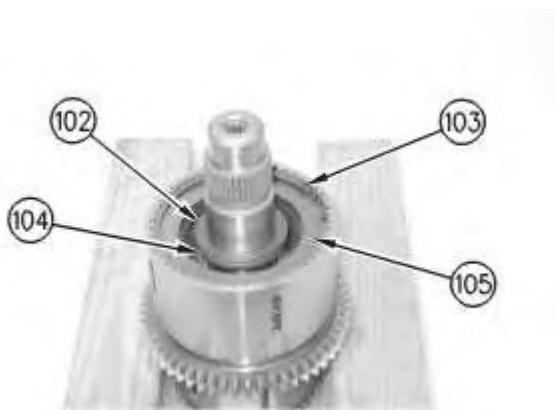

Illustration 56

g00890619

65. Remove washers (102) and (104). Remove retaining ring (103). Remove plates and discs (105).

**Note:** Take note of the number and order of the plates and discs for assembly purposes.

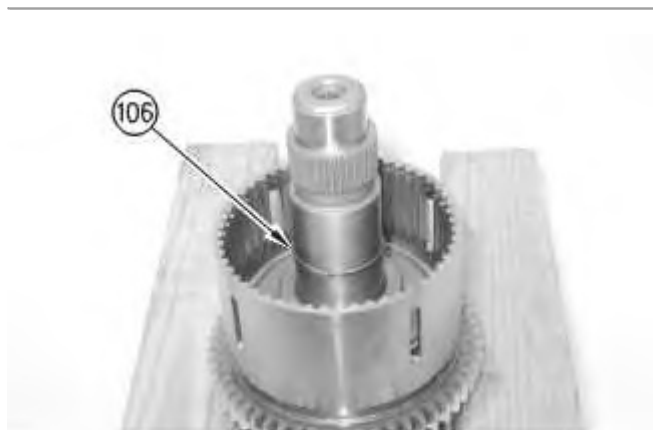

Illustration 57

g00654818

66. Remove ring (106).



Illustration 58

g00654824

67. Remove bearing assembly (107).

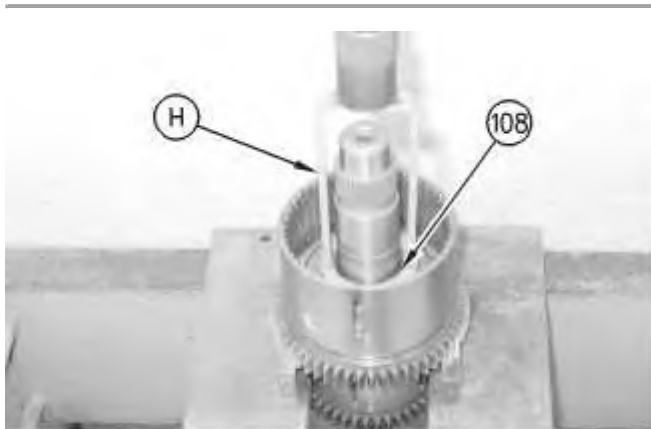

Illustration 59

g00654833



**WARNING**

**Personal injury can result from being struck by parts propelled by a released spring force.**

**Make sure to wear all necessary protective equipment.**

**Follow the recommended procedure and use all recommended tooling to release the spring force.**

- 
68. Put the clutch group in a suitable press. Use Tooling (H) in order to remove retaining ring (108).
-

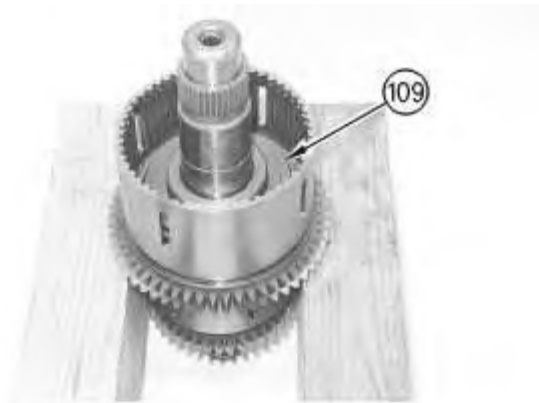

Illustration 60

g00654837

69. Remove the retainer and seal assembly (109).



Illustration 61

g00654842

70. Remove spring (110).

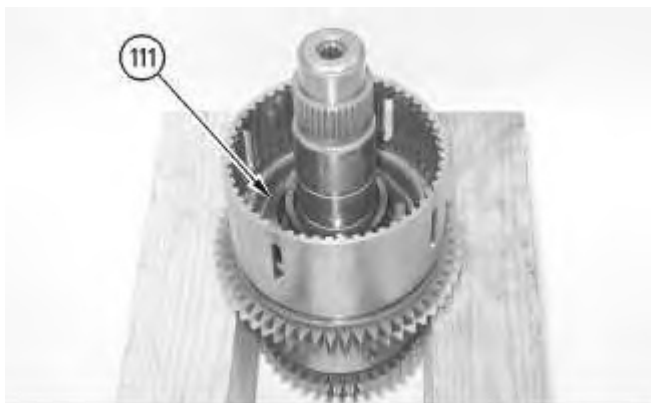

Illustration 62

g00654966

71. Blow shop air 276 kPa to 414 kPa (40 psi to 60 psi) into the lube passage in order to remove piston (111).



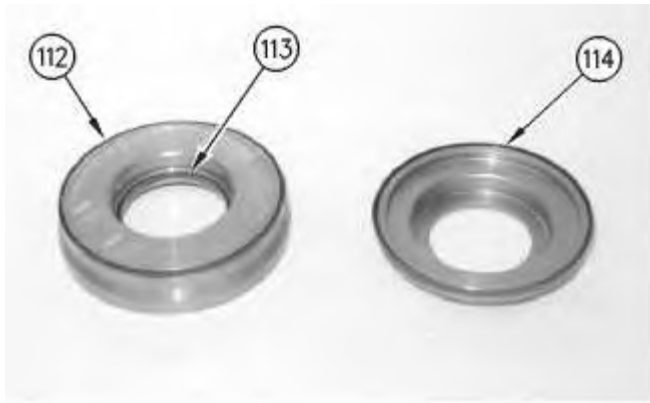

Illustration 63

g00654969

72. Remove seals (112), (113), and (114).

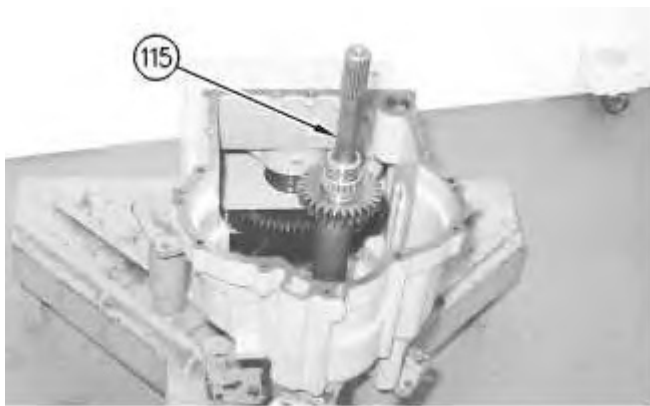

Illustration 64

g00655016

73. Remove input shaft assembly (115).

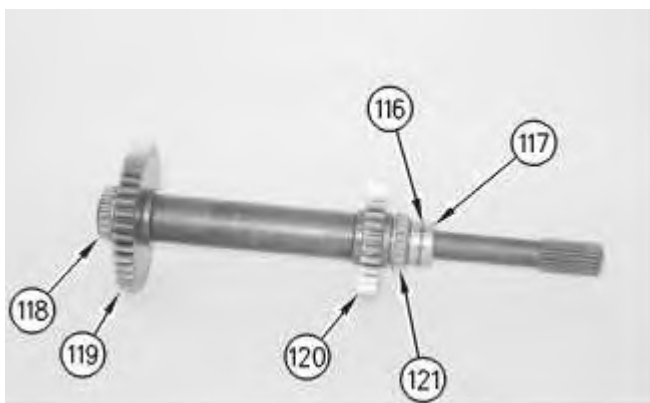

Illustration 65

g00890621

74. Remove carrier (117) and seal (116). Remove bearing cone (121) and gear (120).

75. Remove bearing cone (118) and gear (119).

Thank you so much for reading.  
Please click the “Buy Now!”  
button below to download the  
complete manual.



After you pay.

You can download the most  
perfect and complete manual in  
the world immediately.

Our support email:

[ebooklibonline@outlook.com](mailto:ebooklibonline@outlook.com)