

Product: WHEEL LOADER

Model: 928HZ WHEEL LOADER CXK

Configuration: 928HZ 930H Wheel Loader CXK00001-02021 (MACHINE) POWERED BY C6.6 Engine

Disassembly and Assembly 924H, 924HZ, 928HZ and 930H Wheel Loaders Power Train

Media Number -KENR7606-09

Publication Date -01/03/2015

Date Updated -09/10/2017

i07376985

Transmission and Torque Converter - Disassemble

SMCS - 3001-015

Disassembly Procedure

Table 1

Required Tools			
Tool	Part Number	Part Description	Qty
A	1U-9200	Lever Puller Hoist	1
	138-7575	Link Bracket	3
B	8T-0372	Bolt M12 - 1.75 by 90mm	3
	180-3033	Jack Stand Gp	2
	180-3032	Jack Stand Gp	1
	189-0410	Shackle As	2
C	8T-0644	Bolt M10 - 1.5 by 90mm	2
D	1U-9200	Lever Puller Hoist	1
	138-7575	Link Bracket	4
	189-0409	Shackle As	1
E	154-6181	Forcing Screw	2
F	136-1452	Retaining Ring Pliers As	1
G	1P-0074	Slide Hammer Puller Gp	1
	4C-5653	Threaded Adapter	1

H	1P-1863	Retaining Ring Pliers	1
J	4C-6136	Lifting Bracket	1
K	1P-1861	Retaining Ring Pliers	1
L	1P-0510	Driver Gp	1
M	4C-3652	Compressor Assembly	1
N	1P-1857	Retaining Ring Pliers	1
P	1P-2322	Combination Puller	1
	1P-0510	Driver Gp	1
	1U-9889	Crossblock	1
	3H-0469	Leg	2
Q	3H-0468	Puller Plate	4
	1A-1935	Full Nut	2
	1U-7540	Hydraulic Cylinder	1
	1U-5230	Hand Hydraulic Pump	1
	1H-3110	Bearing Puller Gp	1
R	4C-6399	Compressor Assembly	1

Start By:

- a. Remove the transmission oil pump. Refer to Disassembly and Assembly, "Transmission Oil Pump - Remove".
- b. Remove the transmission and the torque converter. Refer to Disassembly and Assembly, "Transmission and Torque Converter - Remove".

Note: Put identification marks on all hoses, on all hose assemblies, on all harness assemblies, and on all tube assemblies for installation purposes. Plug all hose assemblies and all tube assemblies. This helps to prevent fluid loss, and this helps to keep contaminants from entering the system.

Note: Cleanliness is an important factor. Before you begin the disassembly procedure, the exterior of the components should be thoroughly cleaned. This will help to prevent dirt from entering the internal mechanism. Precision components can be damaged by contaminants or by dirt. Perform disassembly procedures on a clean work surface. Keep components covered and protected at all times.

NOTICE

Care must be taken to ensure that fluids are contained during performance of inspection, maintenance, testing, adjusting, and repair of the product. Be prepared to collect the fluid with suitable containers

before opening any compartment or disassembling any component containing fluids.

Refer to Special Publication, NENG2500, "Dealer Service Tool Catalog" for tools and supplies suitable to collect and contain fluids on Cat[®] products.

Dispose of all fluids according to local regulations and mandates.



Illustration 1

g01392601

1. Attach Tooling (A) and a suitable lifting device to the transmission and the torque converter. The weight of the transmission and torque converter is approximately 476 kg (1050 lb).

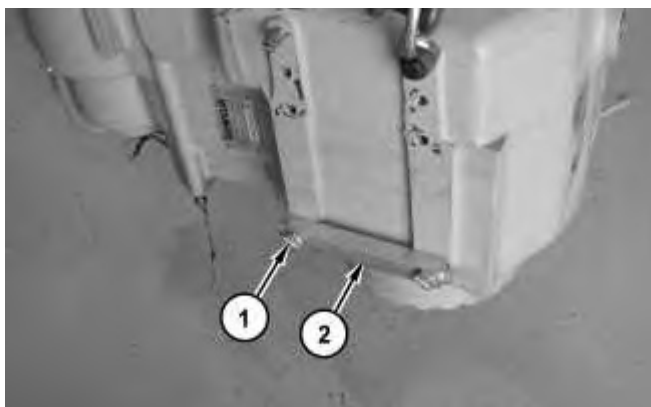

Illustration 2

g01392602

2. Remove bolts (1) and sight gauge (2).
-

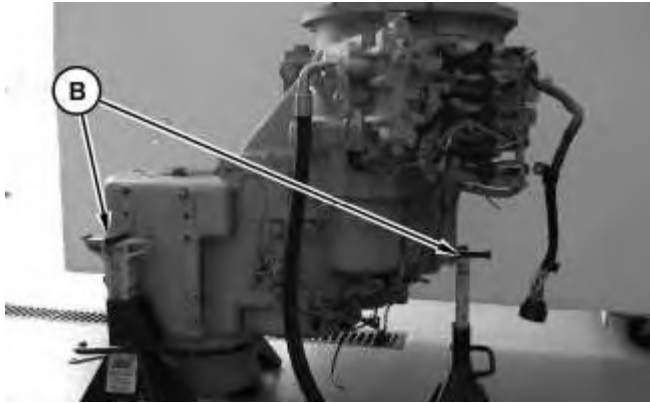

Illustration 3

g01392621

3. Position the transmission and the torque converter onto Tooling (B), as shown.

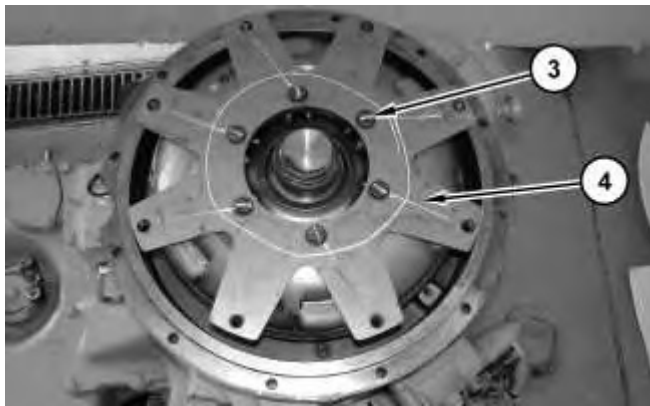

Illustration 4

g01392620

4. Remove bolts (3) and coupling (4).



Illustration 5

g01392597

5. Remove torque converter (5).

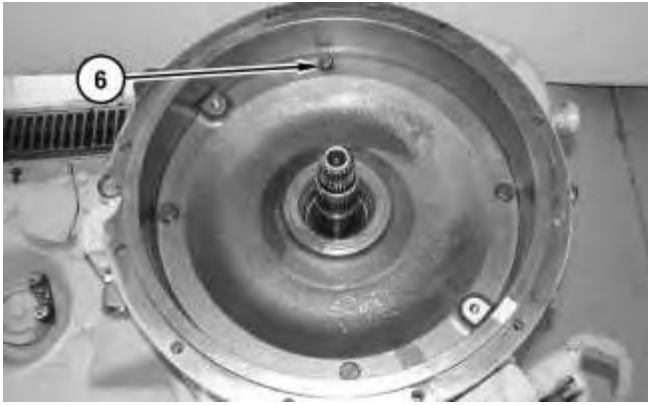

Illustration 6

g01392622

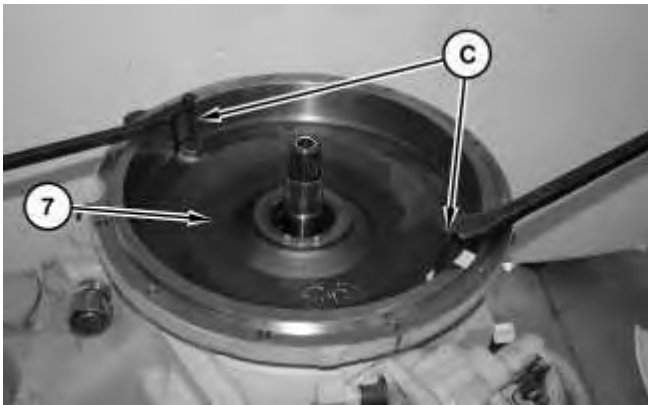

Illustration 7

g01392630

6. Remove bolts (6). Use Tooling (C) and suitable prybars to remove plate (7).



Illustration 8

g01392632

7. Remove O-ring seal (8) from plate (7).



Illustration 9

g01392635

8. Remove O-ring seals (9).

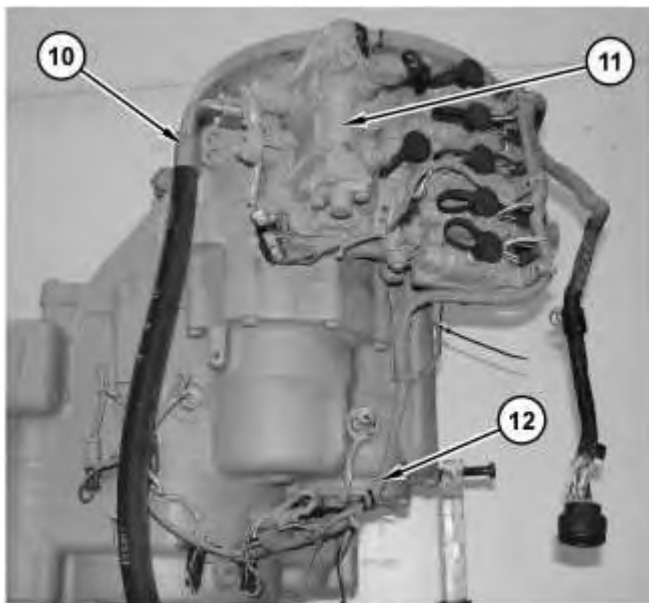

Illustration 10

g01392639

9. Remove hose assembly (10). Disconnect the lower half harness assembly (12) and secure the harness assembly to control valve (11).

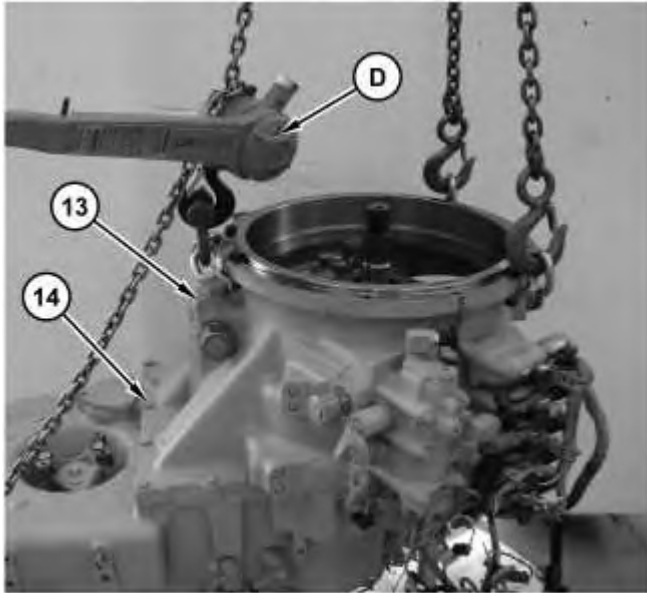

Illustration 11

g01393407

10. Attach Tooling (D) and a suitable lifting device to housing assembly (13). The weight of housing assembly (13) is approximately 141 kg (310 lb).

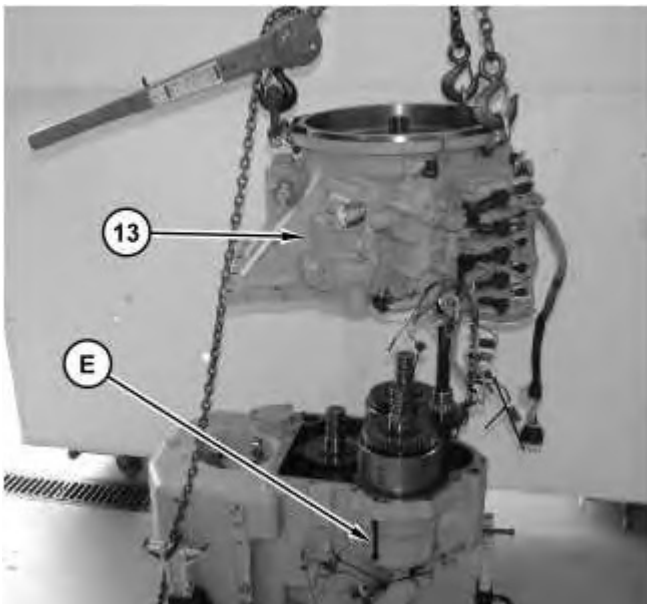

Illustration 12

g01393411

11. Use Tooling (E) to separate the housings. Remove housing assembly (13).

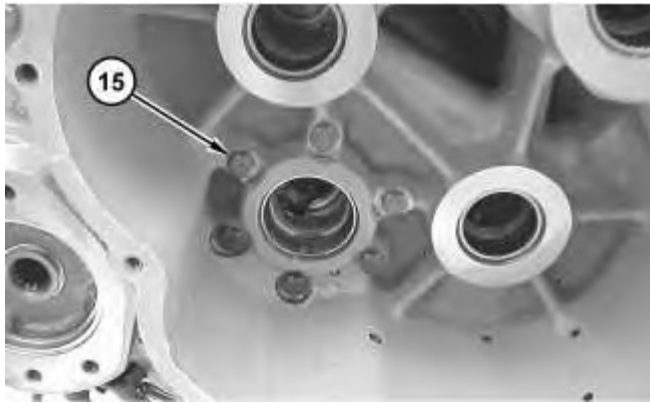

Illustration 13

g01395994



Illustration 14

g01393451

12. Remove bolts (15) and gear assembly (16).



Illustration 15

g01396199

13. Remove bolts (17) and gear (18).

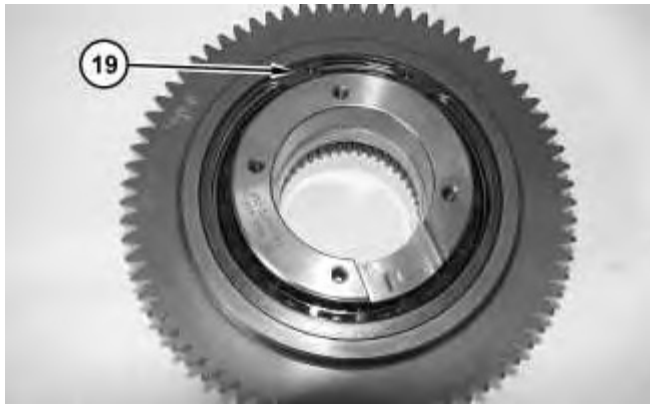

Illustration 16

g01395864

14. Use Tooling (F) to remove retaining ring (19).



Illustration 17

g01396011

15. Use Tooling (G) in a rotating pattern to remove bearing assembly (20).



Illustration 18

g01396014

16. Use Tooling (H) to remove retaining ring (23). Remove bearing support (21). Remove bearing (22) from bearing support (21).

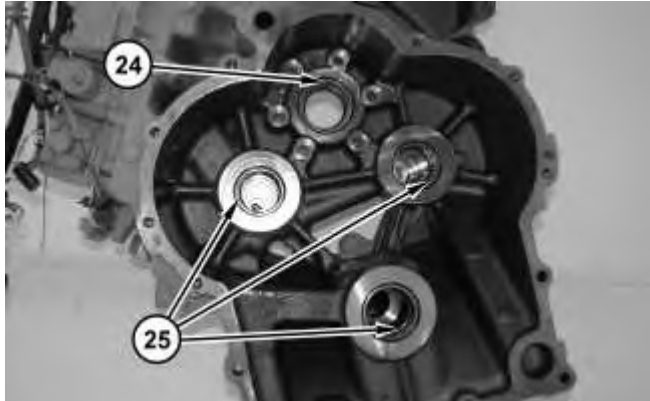

Illustration 19

g01396015

17. Remove bearing cup (24) and bearings (25).

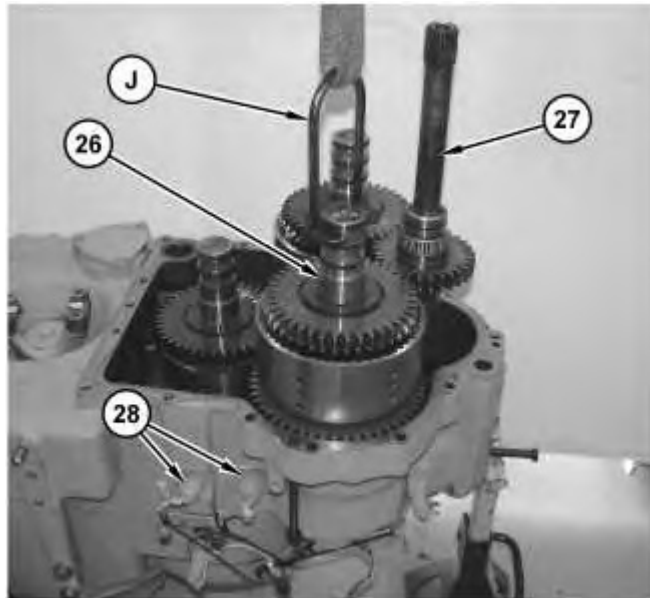

Illustration 20

g01396258

18. Remove sensors (28).
19. Use Tooling (J) and a suitable lifting device to remove the forward low and the forward high clutch group (26). The weight of clutch group (26) is approximately 27 kg (60 lb). Position shaft assembly (27) out of the way and remove clutch group (26).

Note: When the clutch groups are disassembled, remove the plugs in the shaft to clean the oil passages. Use a punch to drive the plug into the shaft. Drill the remainder of the aluminum plug out of the bore. Be careful not to drill any portion of the walls of the bore. Use shop air or a cleaning solution to clean the shafts.

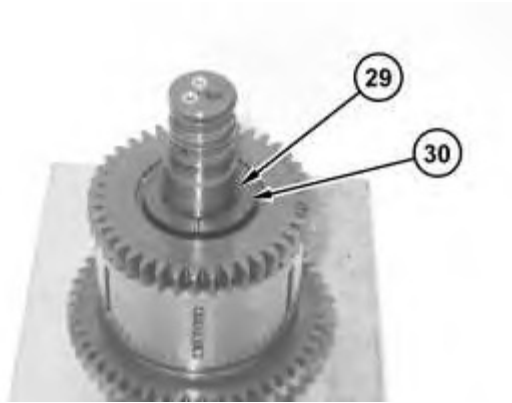

Illustration 21

g01397406

20. Remove retaining ring (29) and thrust disc (30).



Illustration 22

g01397412

21. Remove gear assembly (31).



Illustration 23

g01396271

22. Use Tooling (H) to remove retaining ring (33). Use Tooling (L) to remove hub (32) from gear assembly (31).

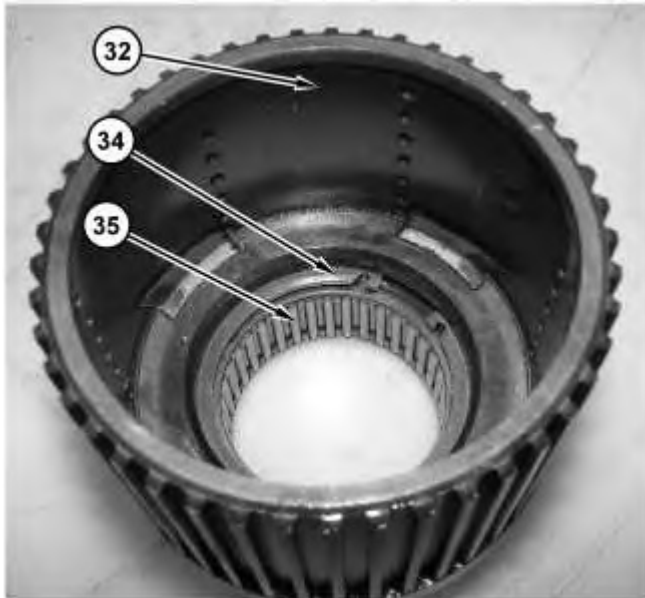

Illustration 24

g01396539

23. Use Tooling (K) to remove retaining ring (34). Use Tooling (L) to remove bearing (35) from hub (32).



Illustration 25

g01396540

24. Remove thrust disc (36).

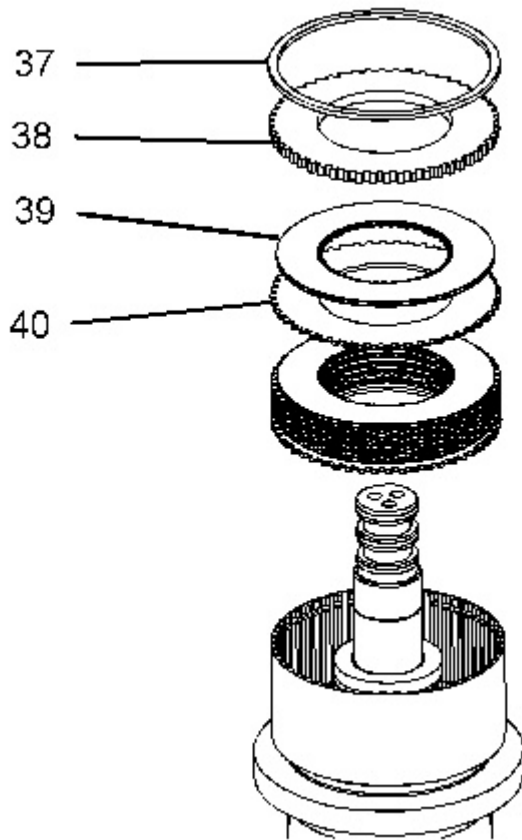

Illustration 26

g01397401

25. Remove retaining ring (37) and plate (38). Remove discs (39) and plates (40).

Note: Note the location of plates and discs for assembly purposes.

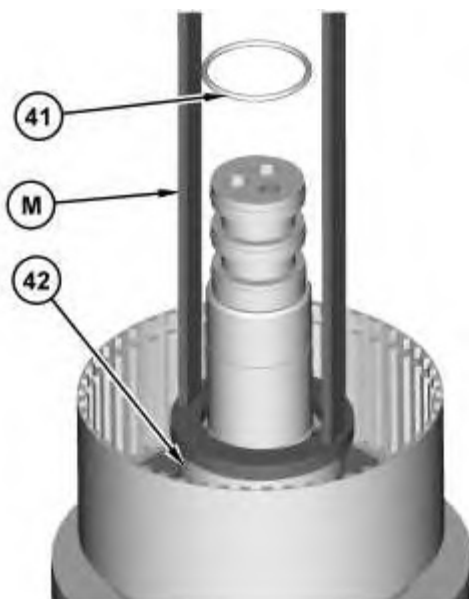

Illustration 27

g01397484

 **WARNING**

Personal injury can result from being struck by parts propelled by a released spring force.

Make sure to wear all necessary protective equipment.

Follow the recommended procedure and use all recommended tooling to release the spring force.

26. Install Tooling (M) onto retainer (42). Use Tooling (M) and a suitable press to compress the clutch spring. Remove retaining ring (41). Slowly release the spring tension.
-

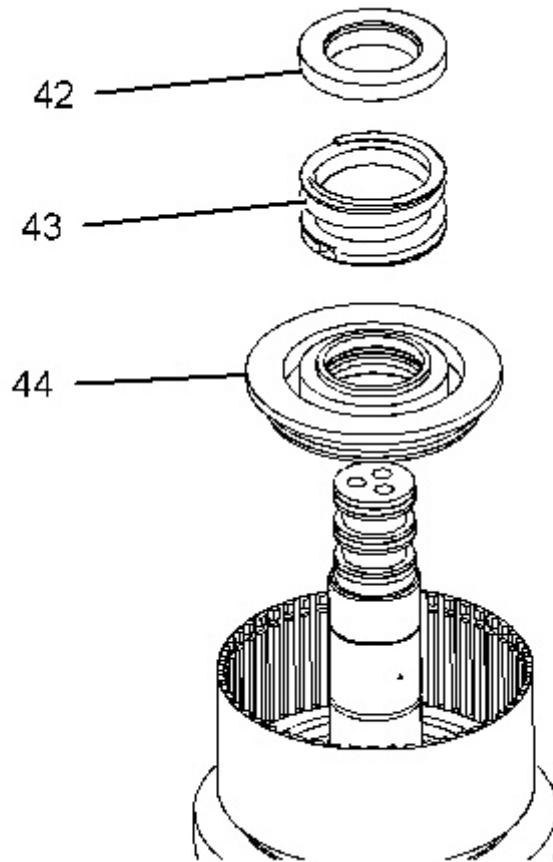

Illustration 28

g01397502

27. Remove retainer (42) and spring (43).
28. Remove piston (44).
-



Illustration 29

g01397562

29. Remove seals (45) from piston (44).

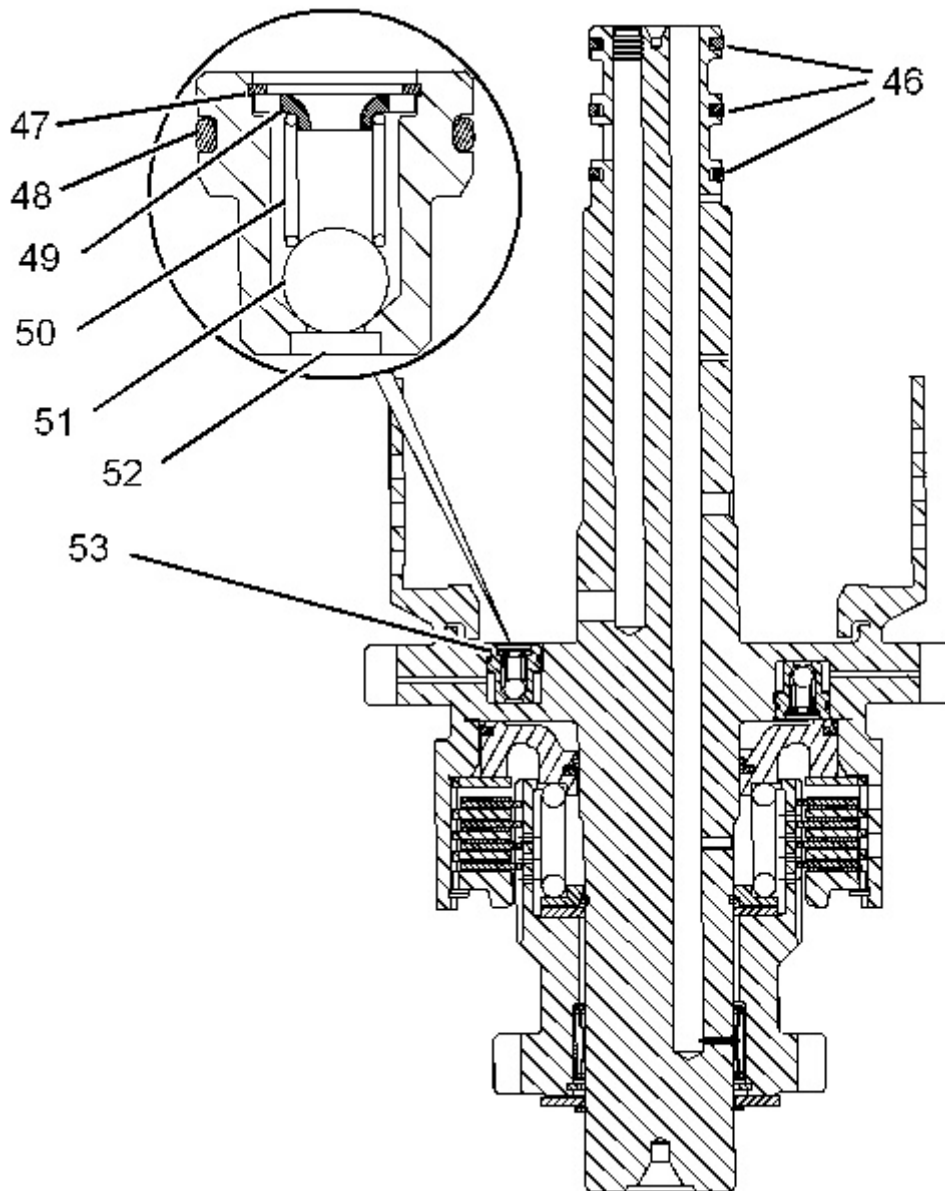

Illustration 30

g01397564

WARNING

Personal injury can result from being struck by parts propelled by a released spring force.

Make sure to wear all necessary protective equipment.

Follow the recommended procedure and use all recommended tooling to release the spring force.

30. If equipped, remove valve assembly (53). Remove seal (48), retaining ring (47), retainer (49), spring (50), and ball (51) from body (52).
31. Remove rings (46).

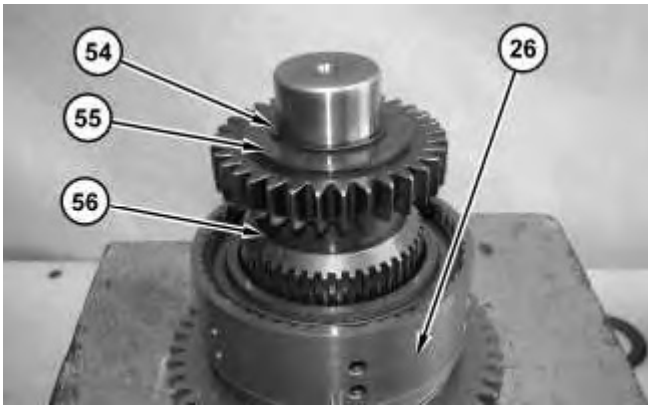

Illustration 31

g01397884

32. Reposition clutch group (26), as shown. Remove retaining ring (54), thrust disc (55), and hub (56).



Illustration 32

g01397964

33. Use Tooling (K) to remove retaining ring (57) from hub (56). Remove bearing (58).

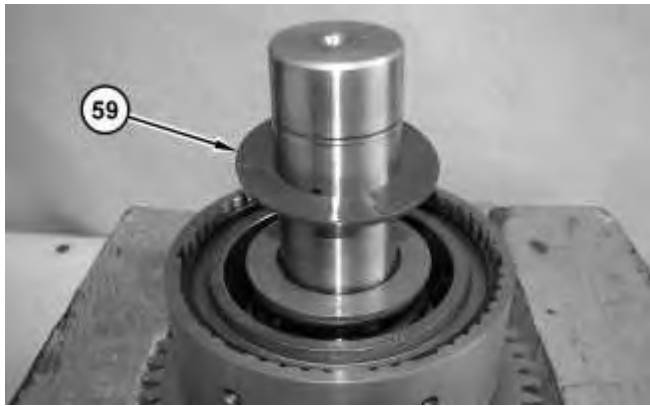

Illustration 33

g01397953

34. Remove thrust disc (59).
35. Repeat Steps 25 through 30 to disassemble the clutch pack.

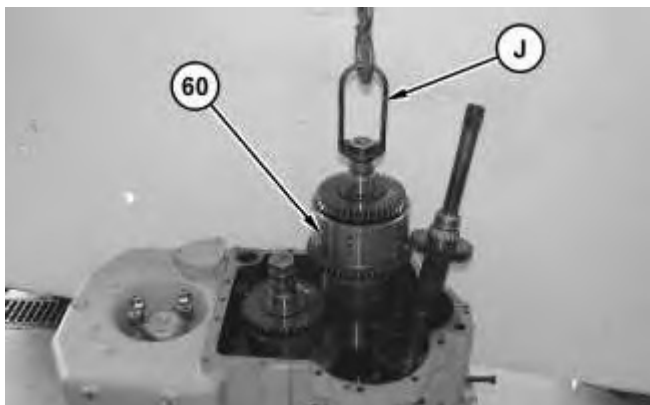

Illustration 34

g01397984

36. Attach Tooling (J) and a suitable lifting device to the reverse and second clutch group (60). The weight of clutch group (60) is approximately 32 kg (70 lb). Position clutch group (60) onto suitable blocking.



Illustration 35

g01397987

37. Remove retaining ring (61), thrust disc (62), and gear (63).



Illustration 36

g01398268

38. Use Tooling (H) to remove retaining ring (65). Use Tooling (L) to remove hub (64) from gear (63).

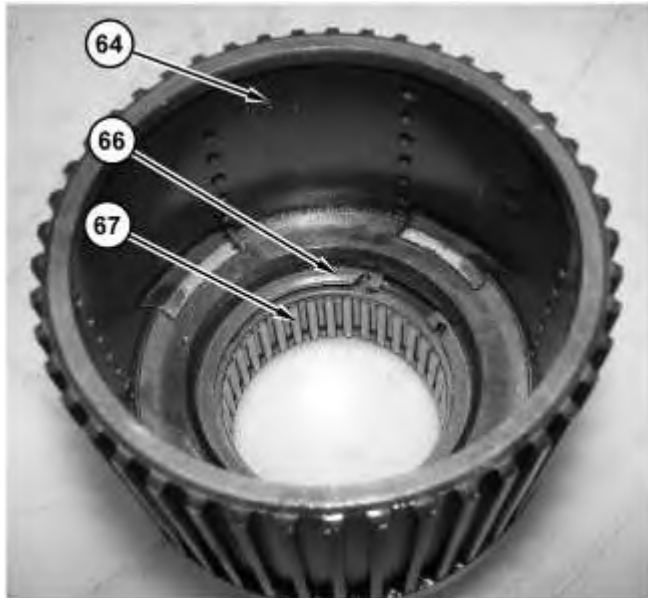

Illustration 37

g01398270

39. Use Tooling (K) to remove retaining ring (66). Use Tooling (L) to remove bearing (67) from hub (64).



Illustration 38

g01398284

40. Remove thrust disc (68).
41. Repeat Steps 25 through 30 for the disassembly of the clutch pack.

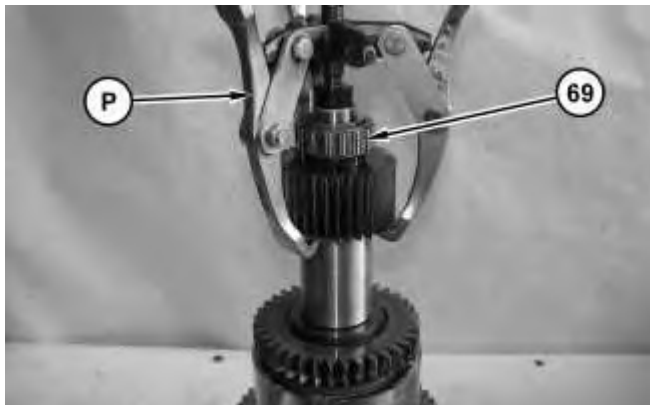

Illustration 39

g01398178

42. Use Tooling (P) to remove bearing (69).
-

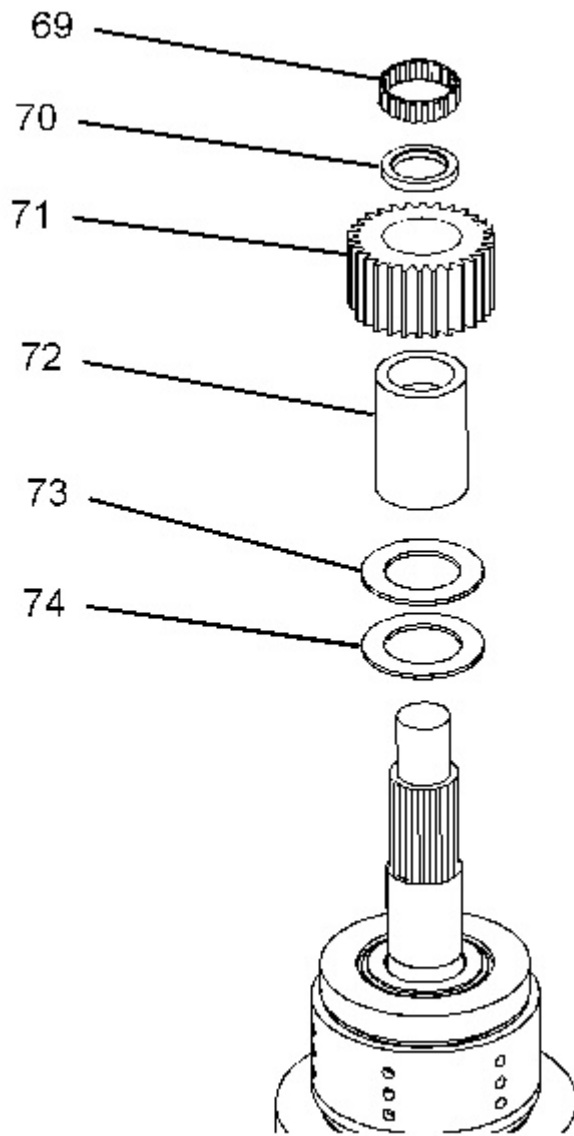

Illustration 40

g01398180

43. Remove bearing (69), spacer (70), gear (71), spacer (72), thrust disc (73), and thrust disc (74).



Illustration 41

g01398280

44. Remove gear (75).

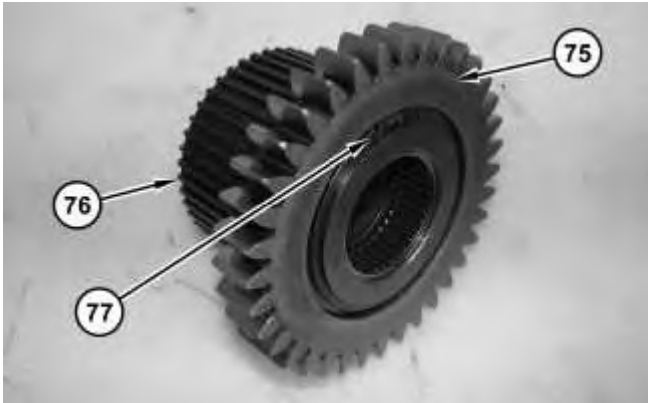

Illustration 42

g01398437

45. Use Tooling (H) to remove retaining ring (77). Use Tooling (L) to remove hub (76) from gear (75).

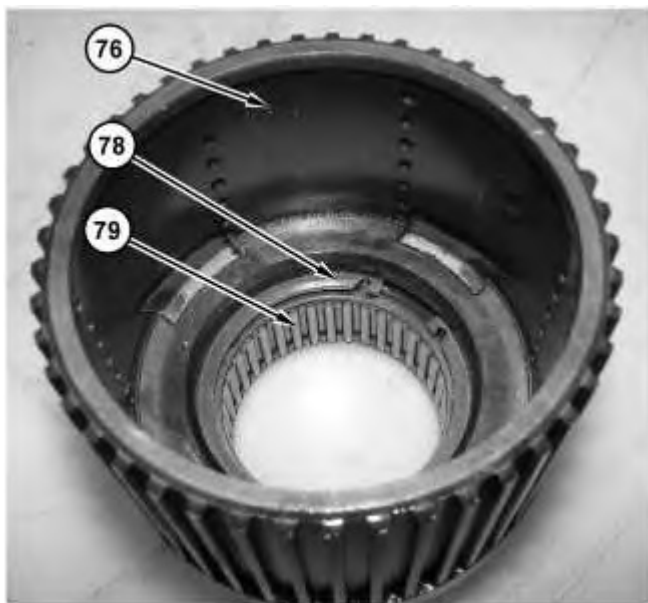

Illustration 43

g01398456

46. Use Tooling (K) to remove retaining ring (78). Use Tooling (L) to remove bearing (79) from hub (76).

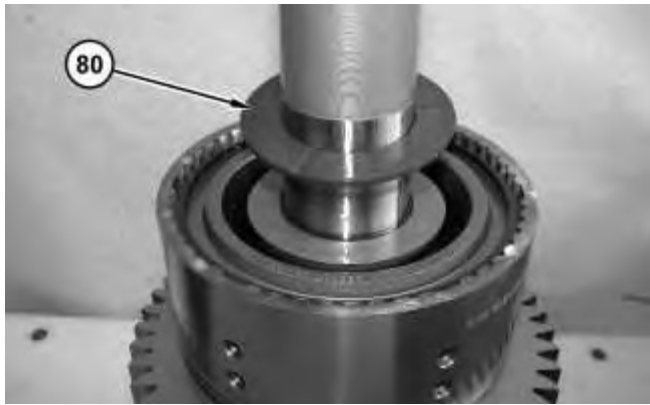

Illustration 44

g01398438

47. Remove thrust disc (80).
48. Repeat Steps 25 through 30 for the disassembly of the clutch pack.

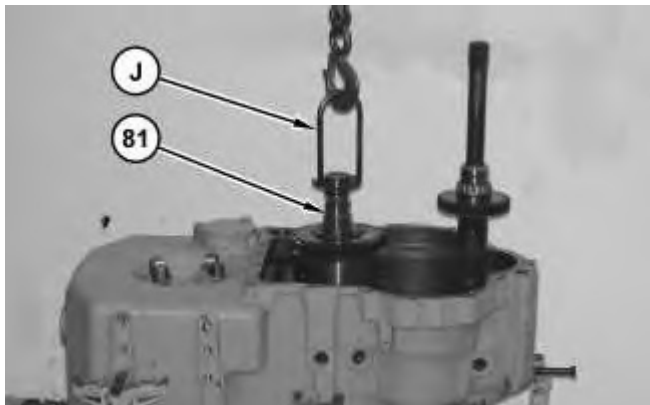

Illustration 45

g01398560

49. Attach Tooling (J) and a suitable lifting device to first gear and third gear clutch group (81). The weight of clutch group (81) is approximately 45 kg (100 lb). Remove clutch group (81).

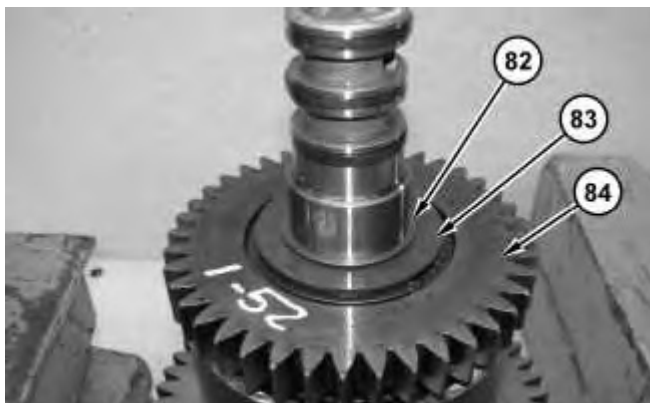

Illustration 46

g01398561

50. Remove retaining ring (82), thrust disc (83), and gear (84).

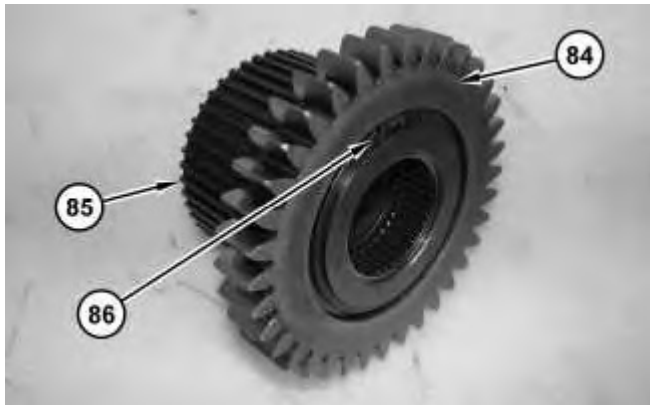

Illustration 47

g01398645

51. Use Tooling (H) to remove retaining ring (86). Use Tooling (L) to remove hub (85) from gear (84).

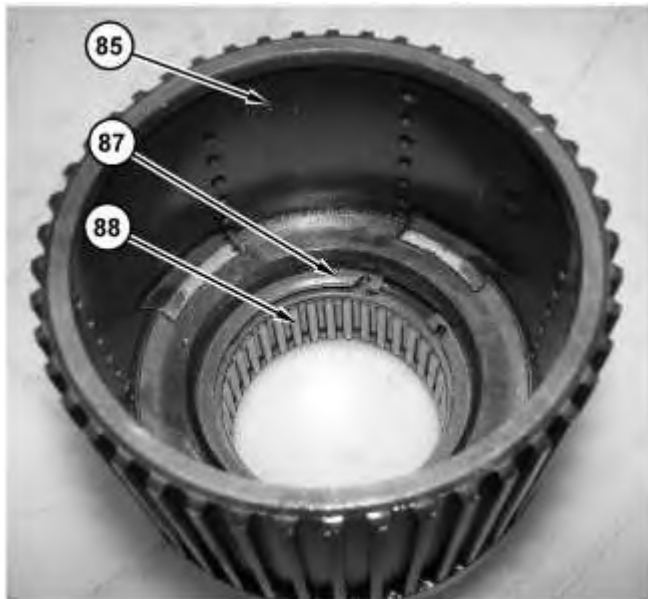

Illustration 48

g01398657

52. Use Tooling (K) to remove retaining ring (87). Use Tooling (L) to remove bearing (88) from hub (85).



- 53. Remove thrust disc (89).
- 54. Repeat Steps 25 through 30 for the disassembly of the clutch pack.



Illustration 50



Illustration 51

- 55. Install Tooling (Q), as shown. Use Tooling (Q) to remove bearing (90). Extend the cylinder several times to remove bearing (90). Use spacers, as needed.



56. Remove spacer (91) and gear (92).

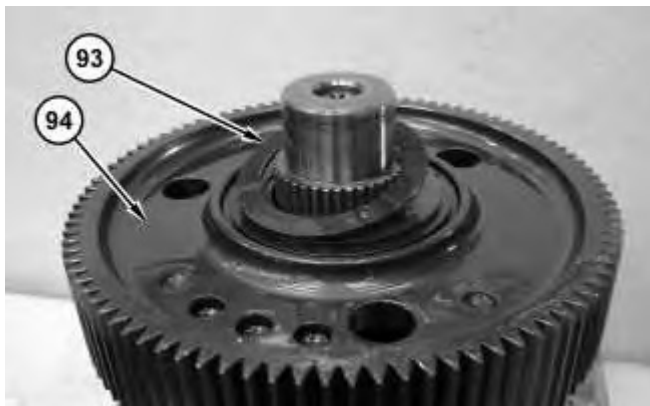

Illustration 53

57. Remove thrust disc (93) and gear (94).



Illustration 54

58. Use Tooling (H) to remove retaining ring (95). Remove hub (96) from gear (94). Use Tooling (L) to remove bearing (97).

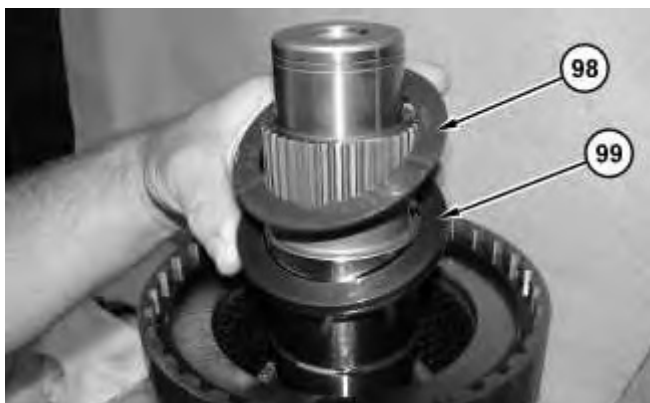

Illustration 55

Thank you so much for reading.
Please click the “Buy Now!”
button below to download the
complete manual.



After you pay.

You can download the most
perfect and complete manual in
the world immediately.

Our support email:

ebooklibonline@outlook.com