

Product: TRACK LOADER
Model: 941 TRACK LOADER 70H
Configuration: 941B TRAXCAVATOR 70H02942-04263 (MACHINE)

Disassembly and Assembly SLEEVE METERING FUEL SYSTEM FOR FOUR AND SIX CYLINDER 4.75"

Media Number -REG01400-01

Publication Date -01/03/1974

Date Updated -17/03/2010

REG01400006

Fuel Injection Pump Housing And Governor

SMCS - 1268-11; 1268-12

Separation Of Governor From Fuel Injection Pump Housing

Tools Needed		A	B
2P8315	Bracket Assembly	1	
5P302	Bar		1

1. Put the fuel injection pump housing on tool (A).

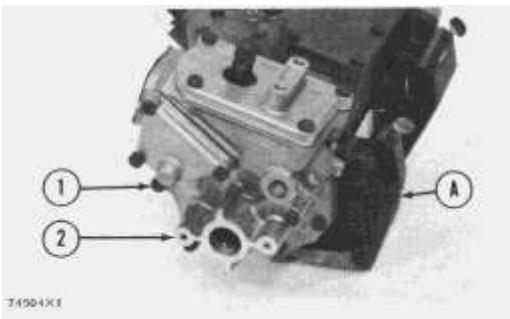

2. Remove bolts (1) that hold the governor housing (2) to the fuel injection pump housing.

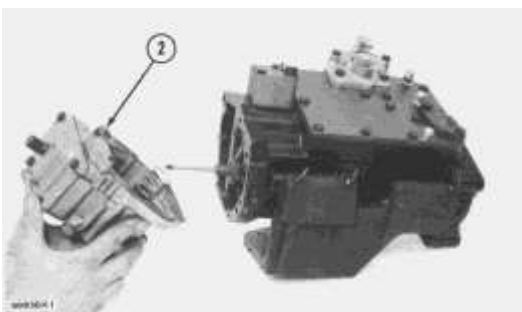

3. Remove governor housing (2) from pump housing.

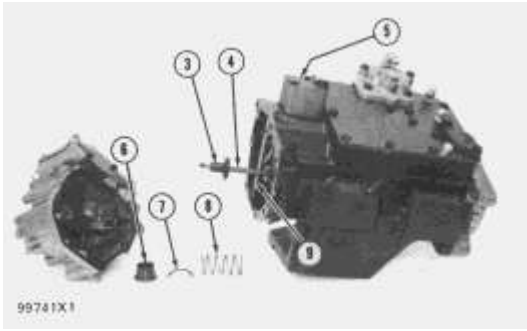

4. Remove cover (5) over the torque spring.

5. Remove spring (8), (wave) washer (7) and guide (6) from governor housing.

6. Remove seat (3) and over fueling spring (4).

7. Pull shaft (9) up and remove shaft and lever from the housing.

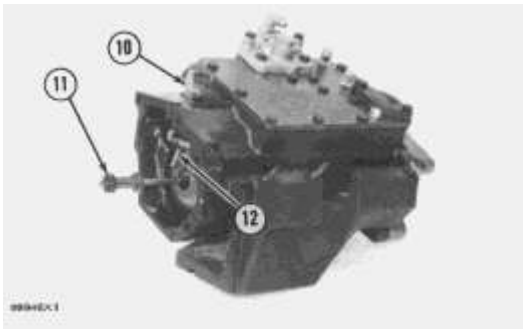

8. Remove torque spring assembly (10) and pin.

NOTE: Some fuel systems do not have a torque spring. They have only a stop.

9. Remove riser (follower) (11) from the shaft.

10. Remove ring and lever (12) from the dowel.

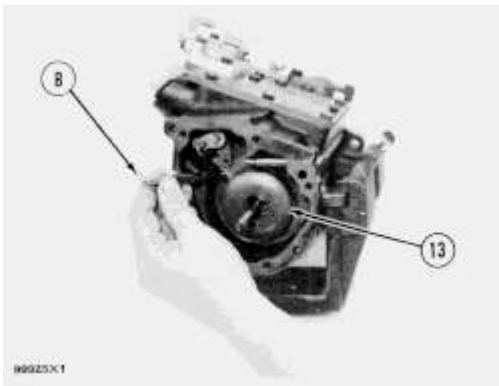

11. Remove cover (13) for the flyweights with tool (B).

NOTE: Tool (B) can cause damage to the cover. Always inspect cover and install a new cover if needed.

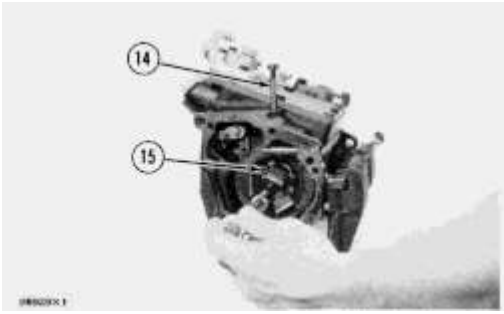

12. Install timing pin (14) to hold the camshaft from turning.
13. Remove bolts (15) that hold flyweight assembly to camshaft.

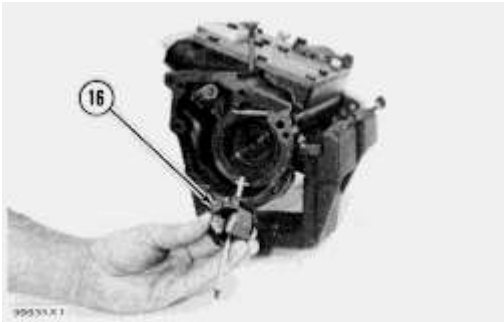

14. Remove the flyweight assembly (16) from the fuel injection pump housing.
15. Remove the timing pin from the housing.

Connection Of Governor To Fuel Injection Pump Housing

Tools Needed		A	B
2P8315	Bracket Assembly	1	
5P301	Driver		1

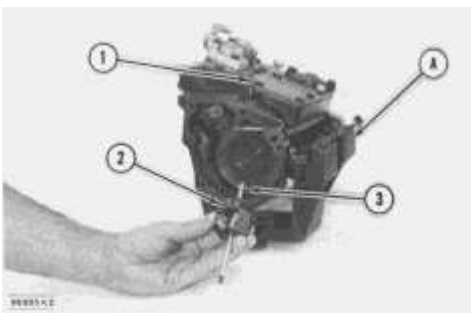

1. Put the fuel injection pump housing on tool (A).
 2. Install timing pin (1) to keep the camshaft from turning.
 3. Put flyweight assembly (2) in position on the camshaft.
-

NOTICE

Be sure pin (3) that holds shaft is in the correct position on back of the flyweight assembly.

4. Install new bolts for the flyweight assembly.

NOTE: The bolts for the flyweight assembly have a locking material on the threads and must not be used more than one time.



5. Install cover over the flyweight assembly with tool (B).

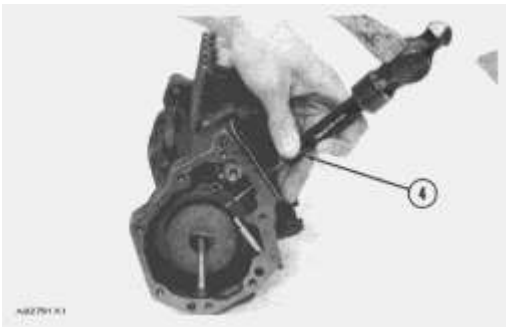

6. Grind a taper on the bottom edge of a 1/8" screwdriver (4). Install the screwdriver through the bolt hole in the governor housing. The screwdriver must fit evenly against the flyweight assembly cover. Make a mark (stake) in four places around the cover in line with the groove in the camshaft.

NOTICE

Never install a used flyweight cover that is bent.

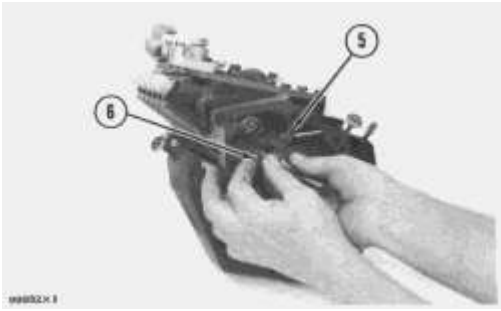

7. Install lever (5) on the dowel. Install ring (6) that holds lever on dowel.

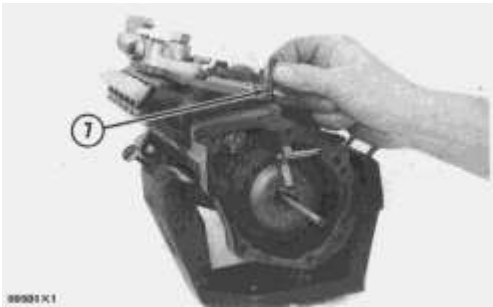

8. Install pin (7) in the housing with the round end down.

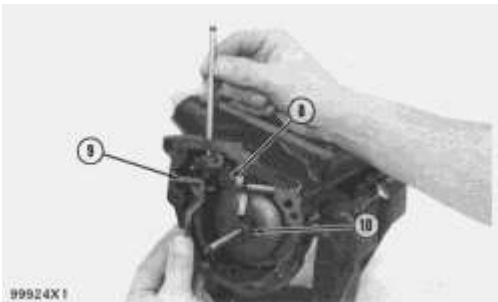

9. Put riser (follower) (10) in position between the flyweights. Lift the flyweight up with a piece of wire and push riser (follower) forward.

10. Put lever (9) into position in groove of riser (follower) (10) and ball end engaged in the sleeve shaft lever (8). Install shaft to hold lever in place.

NOTICE

If lever (9) is not installed correctly, the governor cannot operate and can cause the engine to over speed.

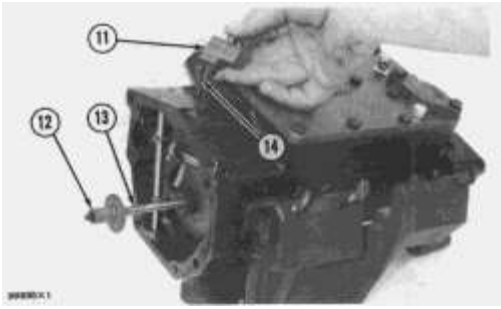

11. Install over fueling spring (13) and seat (12) on shaft.
12. Install stud (14) and torque spring or stop bar (11) on the housing.

NOTICE

The screw that holds the torque spring must not go beyond the inner surface of the governor housing.

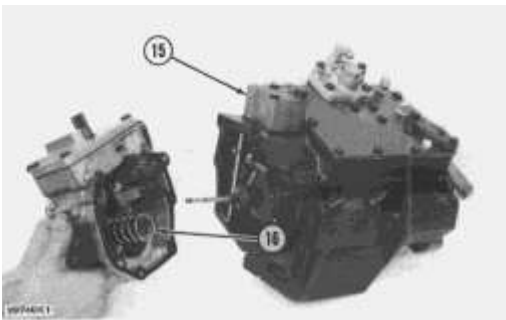

13. Install cover (15) over torque spring after adjustment has been made.
14. Install guide, (wave) washer and spring (16) in the governor housing.
15. Put the governor housing on the fuel injection pump housing and install the bolts.

end by:

- a) make adjustment of fuel system setting (See Fuel System Setting in Testing and Adjusting)
-

Product: TRACK LOADER
Model: 941 TRACK LOADER 70H
Configuration: 941B TRAXCAVATOR 70H02942-04263 (MACHINE)

Disassembly and Assembly SLEEVE METERING FUEL SYSTEM FOR FOUR AND SIX CYLINDER 4.75"

Media Number -REG01400-01

Publication Date -01/03/1974

Date Updated -17/03/2010

REG01400007

Governor

SMCS - 1264-15; 1264-16

Disassemble Governor

start by:

a) separation of governor from fuel injection pump housing

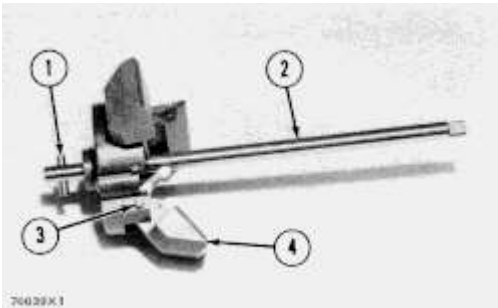

1. Remove shaft (2). Remove pin (1) from shaft.
2. Remove pins (3) from the flyweights. Remove flyweights (4).

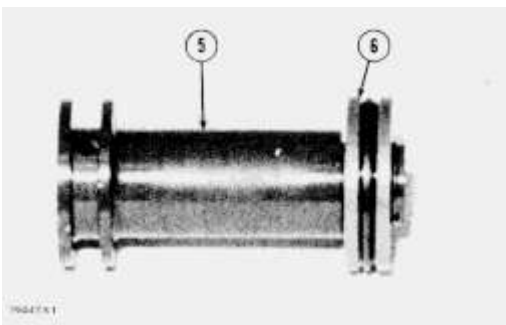

3. Remove ring, races (6) and bearing from the riser (follower) (5).

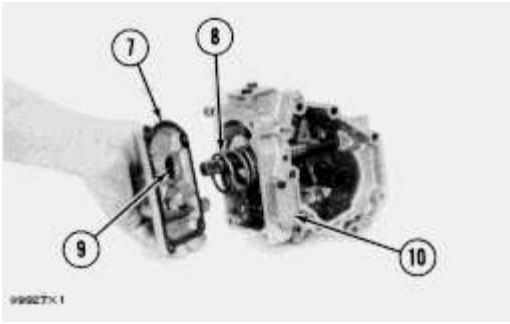

4. Remove cover (7) and spring (8) from governor housing.

NOTE: There is force on the cover from the spring.

5. Remove seal (9) from cover.

6. Remove cover (10) for the low and high idle adjustment.

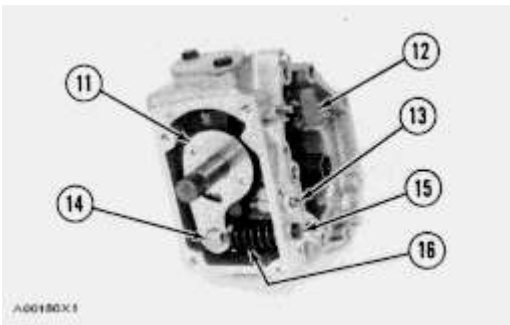

7. Remove locknut and screw (13) for the high idle adjustment.

8. Remove bolt (15) and washers for the low idle adjustment.

9. Remove spring (16) and guide.

10. Remove pin (14) and plate (11).

11. Remove shaft (12) from the housing.

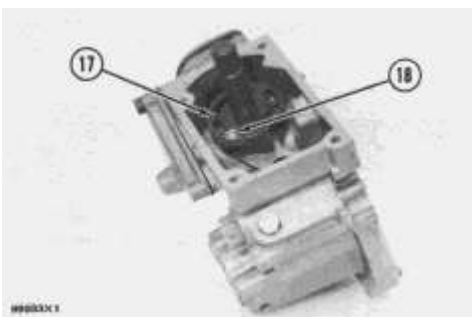

12. Remove pin (18) and two spacers (17) from shaft.

NOTE: Earlier fuel systems have a ball in place of spacers (17) and pin (18).

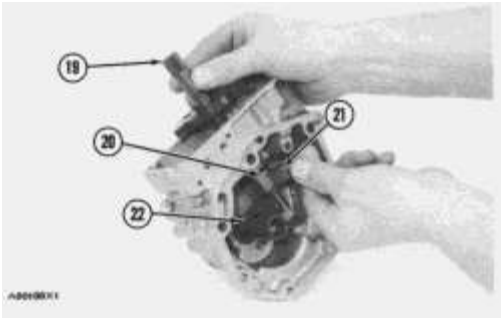

13. Remove shaft (19) from the governor housing.

14. Remove washer (20) and levers (21) and (22) from governor housing.

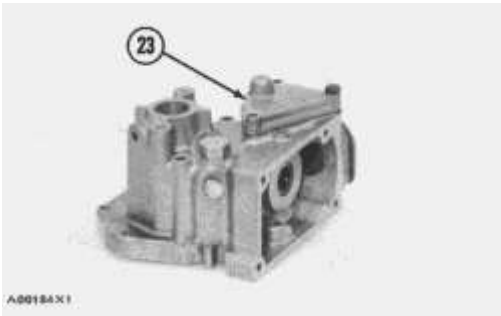

15. Remove cover (23) from governor housing.

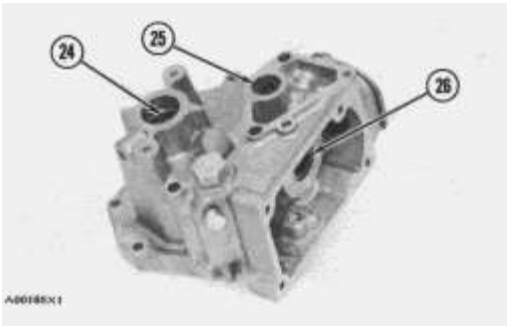

16. Remove seal (25) and bearing.

17. Remove seals (24) and (26) from governor housing.

Assemble Governor

Tools Needed		A	B
1P529	Handle	1	1
1P457	Drive Plate		1
1P471	Drive Plate		1

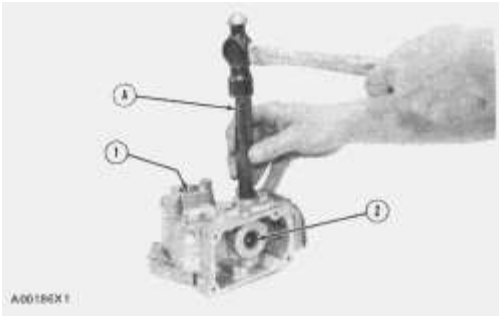

1. Install bearing and seal in the housing with tool (A). The lip of the seal must be toward the bearing.
2. Install seal (1) in housing with tool (A). The lip of seal must be toward inside of housing.
3. Install seal (2) in housing with tooling (B). The lip of seal must be toward the inside of housing.

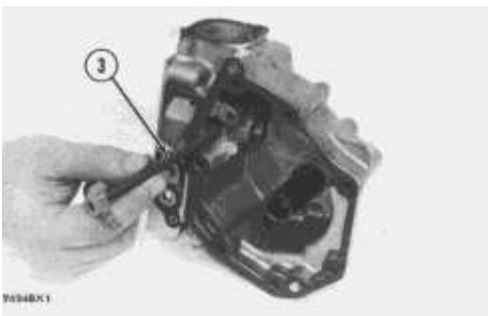

4. Install shaft (3) in the housing.

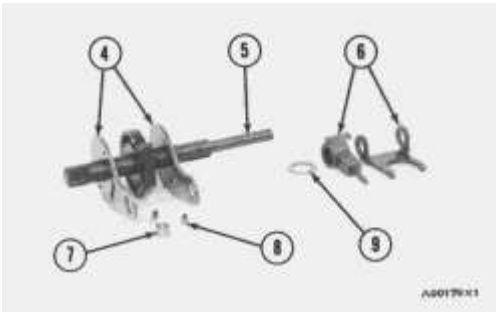

5. Install plates (4), spacers (8) and pin (7) on shaft.
6. Install shaft (5) in housing and through washer (9) and levers (6).

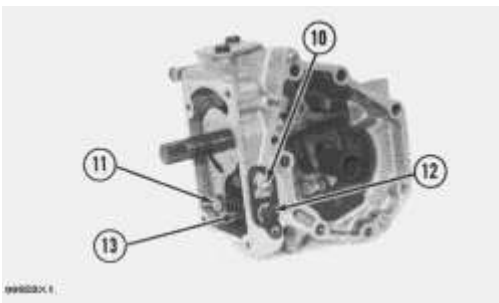

7. Install pin (11) in holes of the plates.
8. Install screw (10) and locknut for high idle adjustment.

9. Install spring (13) and guide.

10. Install bolts (12) and washer for low idle adjustment.

11. Push plate and pin (11) over toward the bolt (12) and tighten the bolt.

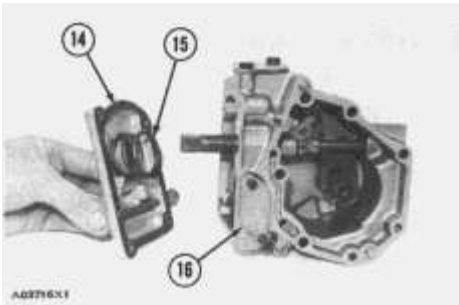

12. Install seal in cover with tooling (B). The lip of seal must be toward the inside.

13. Install spring (15) in the cover. Install cover (14) on housing.

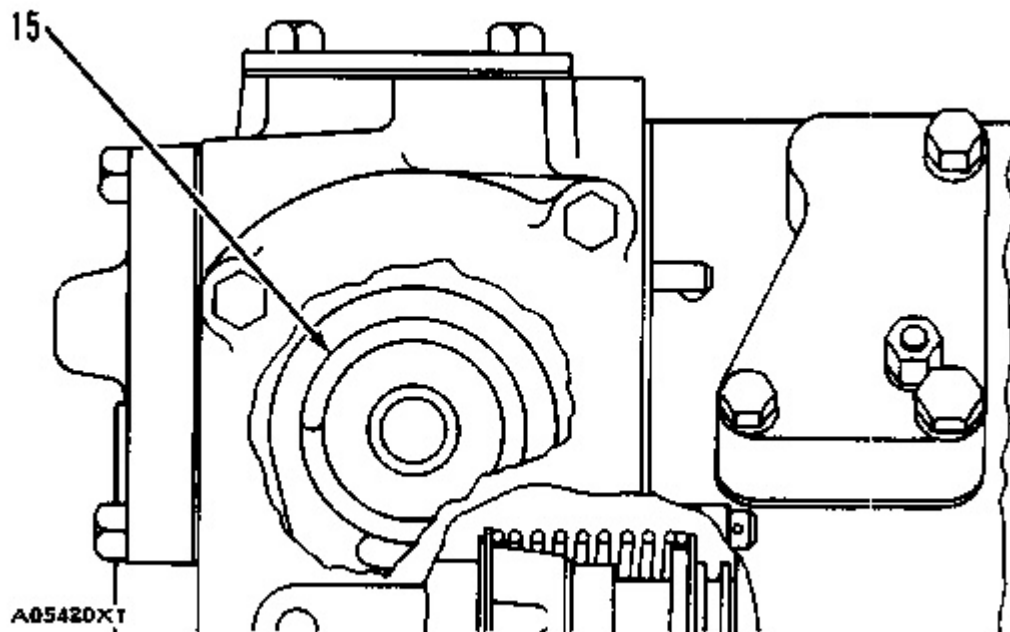

NOTICE

The spring (15) must be installed with the end of spring as shown.

14. Install cover (16) for the idle adjustment screws.

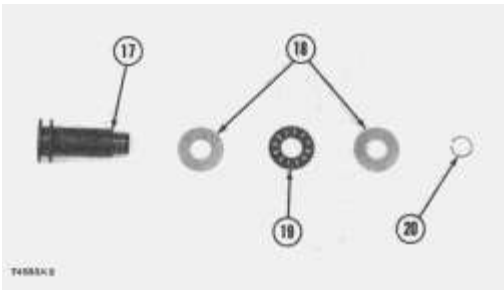

15. Install bearing (19) between the races (18) on riser (follower) (17). Install ring (20) that holds the washers on the riser (follower).

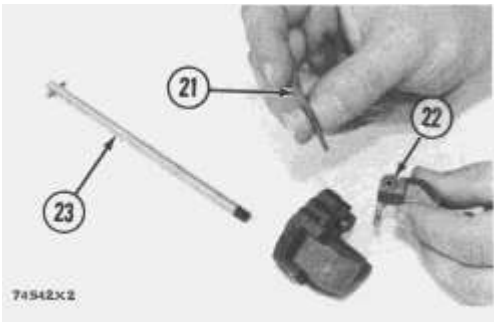

16. Install pin in shaft (23).

17. Install flyweights (22) and pin (21).

18. Install shaft (23) in the flyweight assembly.

end by:

a) connection of governor to fuel injection pump housing

Product: TRACK LOADER
Model: 941 TRACK LOADER 70H
Configuration: 941B TRAXCAVATOR 70H02942-04263 (MACHINE)

Disassembly and Assembly SLEEVE METERING FUEL SYSTEM FOR FOUR AND SIX CYLINDER 4.75"

Media Number -REG01400-01

Publication Date -01/03/1974

Date Updated -17/03/2010

REG01400008

Fuel Check Valve And Bypass Valve

SMCS - 1264-15; 1264-16

Remove Fuel Check Valve And Bypass Valve

Tools Needed		A
2P8315	Bracket Assembly	1

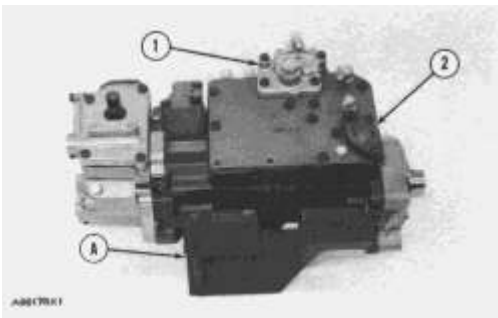

1. Remove fuel from the pump housing and install on tool (A).
2. Remove cover (2) from top cover.
3. Remove fuel inlet and return housing (1) from top cover.

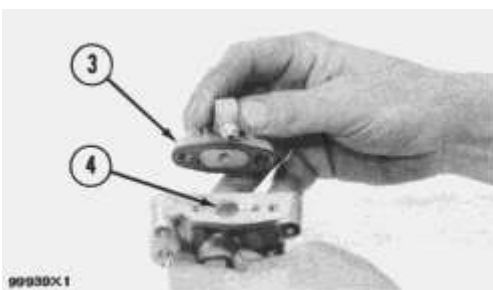

4. Remove elbow (3) and disc (4) from fuel inlet and return housing.

NOTE: The function of the disc (4) is to keep the fuel in the pump housing from returning to the tank when the engine is not in operation. If the fuel tank is higher than the fuel pump housing, disc and housing is not needed.

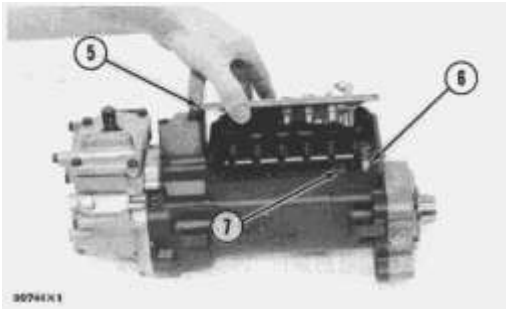

5. Remove cover (5) and fuel channel from pump housing.

6. Remove spring and bypass valve (6) from housing.

7. Remove check valve (7).

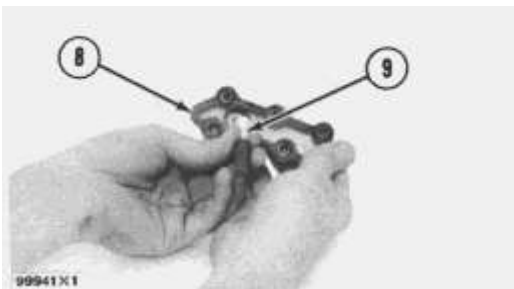

8. Remove fuel channel (8) and check valve from cover.

9. Remove check valve (9) and spring from fuel channel.

NOTE: Earlier fuel systems have two check valves (7) and (9). Check valve (9) is not needed. Remove check valve (9) and fill the hole in fuel channel with weld or replace channel.

Install Fuel Check Valve And Bypass Valve

Tools Needed		A
2P8315	Bracket Assembly	1

1. Install fuel channel (1) on cover (2).

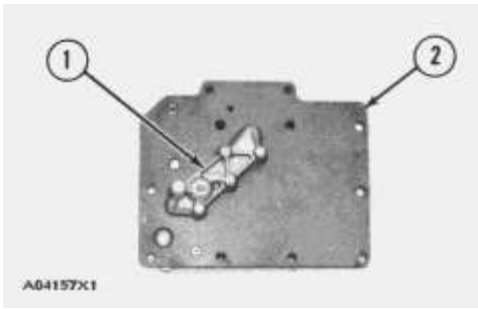

2. Install spring and bypass valve (4) in housing with the rounded end up.

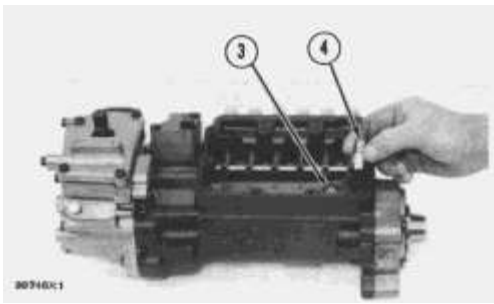

3. Install check valve (3) evenly in pump housing.

NOTE: Do not install a check valve that is bent.

4. Install cover on pump housing. Be sure the bypass valve spring is in the groove in the cover.

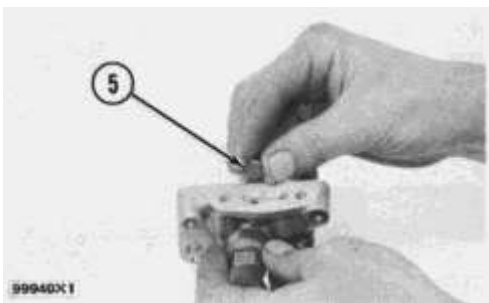

5. Install disc (5) and elbow on fuel inlet and return housing.

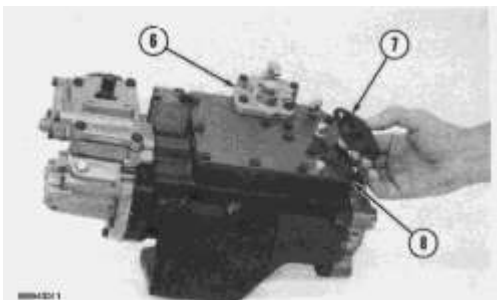

6. Install fuel inlet and return housing (6) on cover (8).

7. Install cover (7) on cover (8).

8. Remove fuel injection pump housing and governor from tool (A).

Product: TRACK LOADER

Model: 941 TRACK LOADER 70H

Configuration: 941B TRAXCAVATOR 70H02942-04263 (MACHINE)

Disassembly and Assembly

SLEEVE METERING FUEL SYSTEM FOR FOUR AND SIX CYLINDER 4.75"

Media Number -REG01400-01

Publication Date -01/03/1974

Date Updated -17/03/2010

REG01400009

Fuel Injection Pumps

SMCS - 1251-11; 1251-12; 1251-15; 1251-16

Fuel Injection Pump And Housing

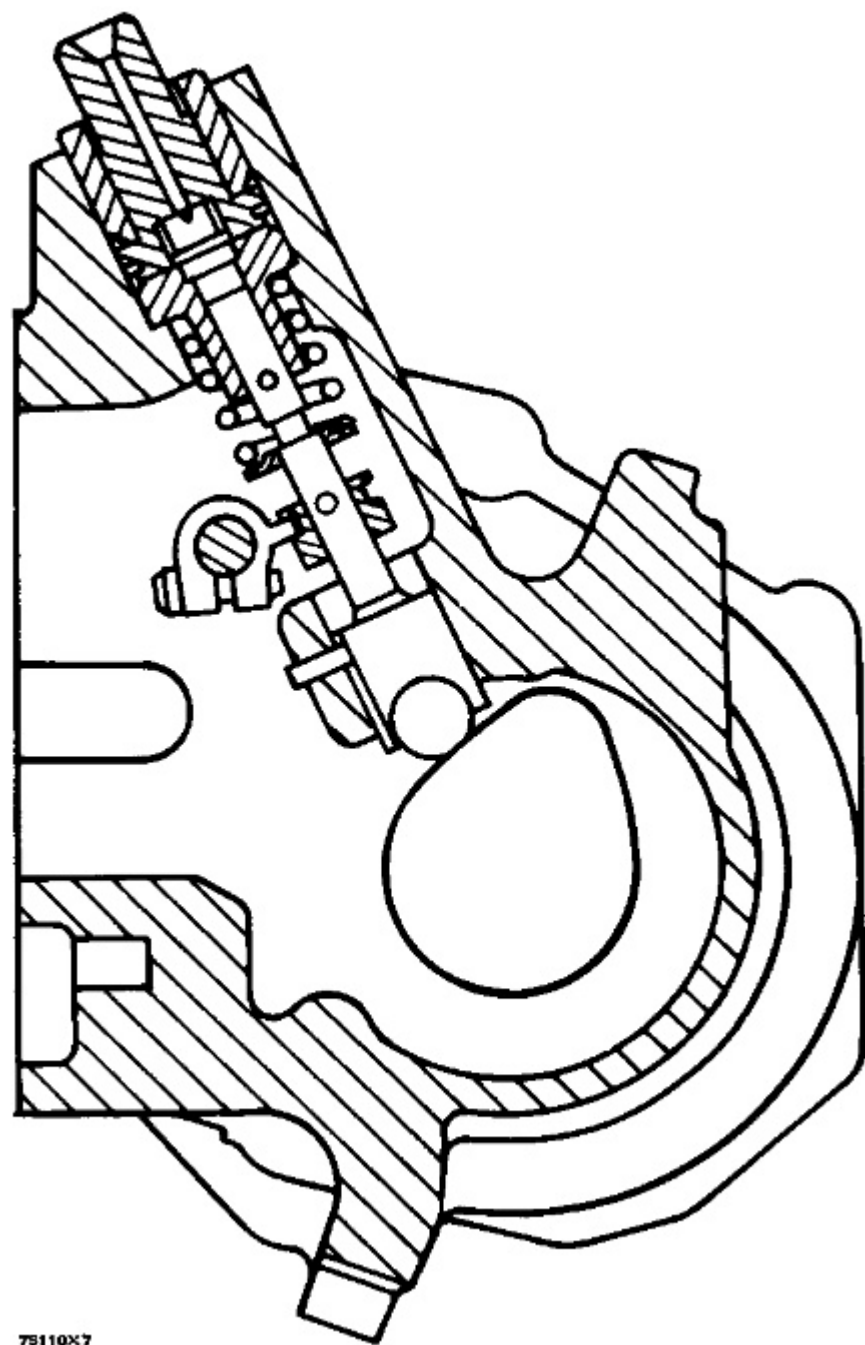

75110X7

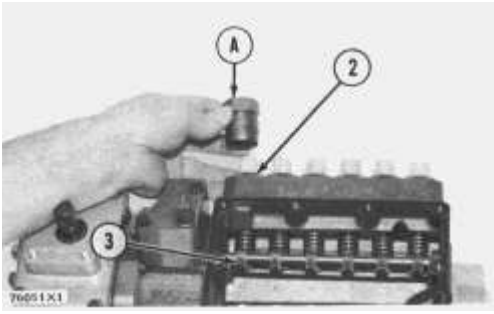

2. Loosen the bushing (2) from the pump housing with tool (A).

NOTE: Do not loosen the screws (3) that hold levers to shaft when removing or installing pumps. If levers are moved, fuel pump adjustment will be changed.

3. Remove the fuel injection pump from the pump housing. The sleeve on the plunger will slide off the lever as the pump is removed.

Install Fuel Injection Pumps

Tools Needed		A
8S2243	Wrench	1

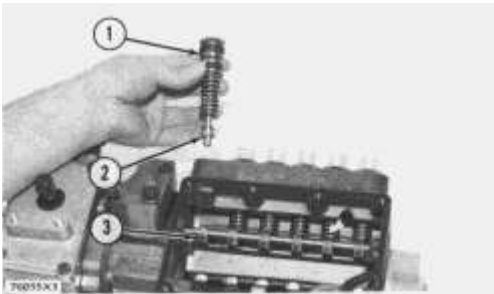

1. Put the fuel injection pump (1) in the bore of pump housing.

2. The sleeve (2) will be engaged with lever when installed correctly.

NOTICE

If levers have been moved on the shaft, fuel pump adjustment must be made. (See TESTING AND ADJUSTING).

3. Tighten the bushing with wrench (A) to a torque of 70 ± 5 lb.ft. (9.7 ± 0.7 mkg).

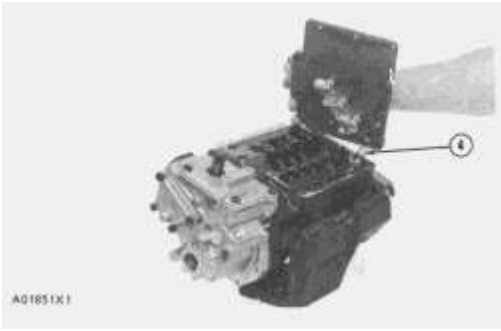

4. Put the spring on the bypass valve. Install the cover assembly on the pump housing. Be sure the spring (4) is in position in the cover.

Disassemble Fuel Injection Pumps

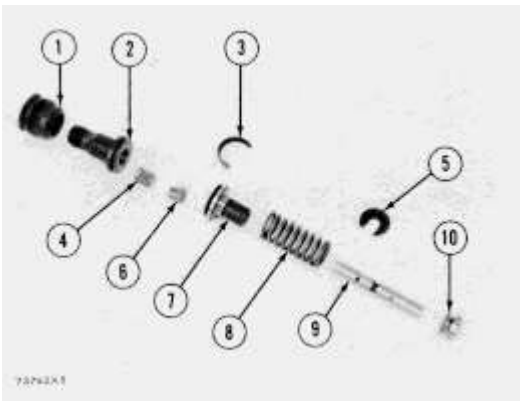

start by:

a) remove fuel injection pumps

1. Remove the bushing (1) from the bonnet (2).

2. Remove the ring (3) from the bonnet and barrel (7). Remove the check valve (6) and spring (4) from the bonnet.

3. Remove the spring (8) and washer (5). Remove the plunger (9) and sleeve (10).

NOTE: Keep the plunger and sleeve with their respective barrel for installation. Do not use plungers, sleeves, and barrels with other plungers, sleeves, and barrels.

Assemble Fuel Injection Pumps

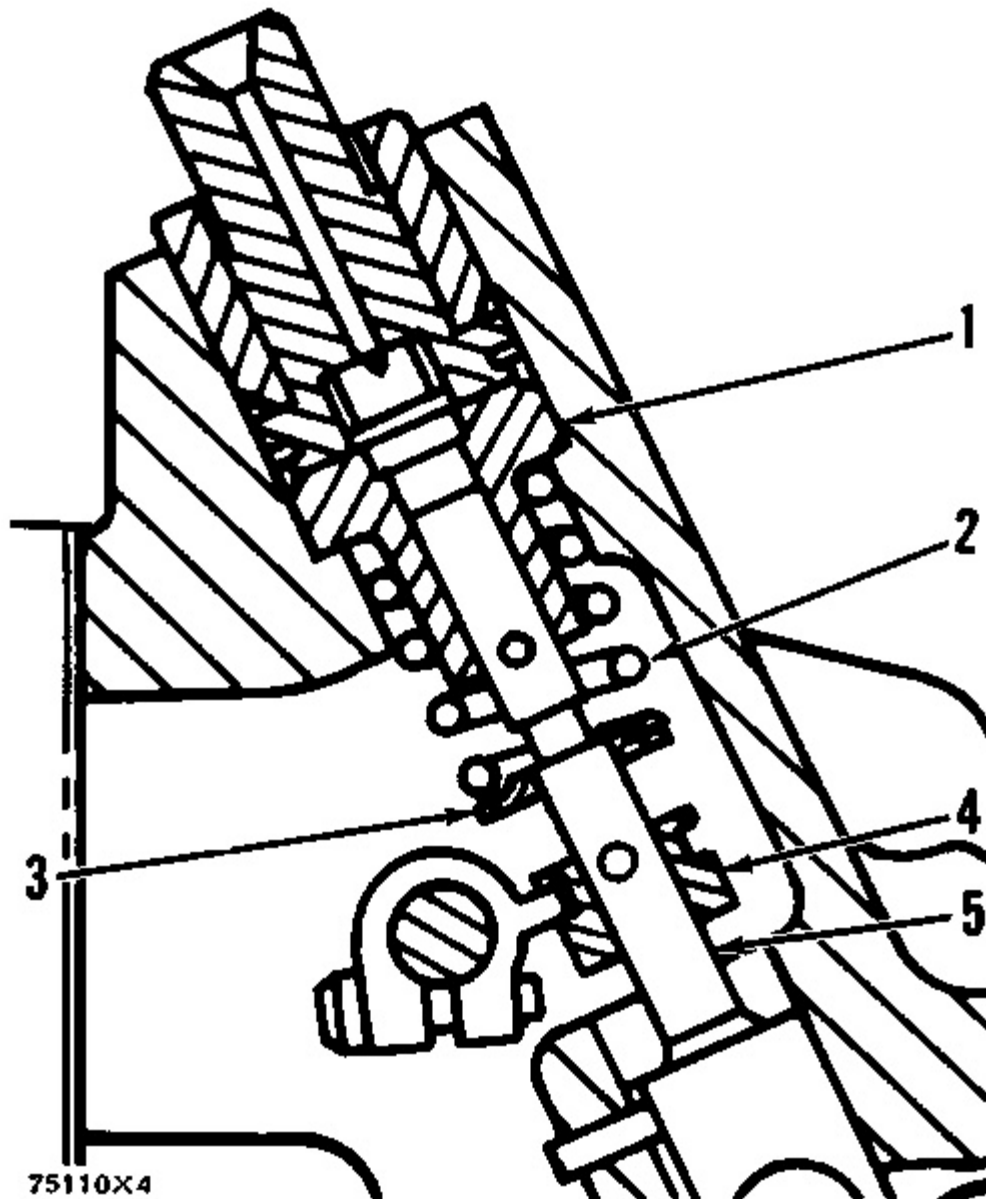

1. Install the sleeve (4), plunger (5), spring (2), and washer (3) on the barrel (1).

NOTE: Be sure sleeve and plunger are installed in original barrel, and large hole in plunger is up.

2. Install check valve and spring in bonnet. Connect the barrel and bonnet and install the ring. Install the bushing on the bonnet.

end by:

a) install fuel injection pumps

Thank you so much for reading.
Please click the “Buy Now!”
button below to download the
complete manual.



After you pay.

You can download the most
perfect and complete manual in
the world immediately.

Our support email:

ebooklibonline@outlook.com