

Product: WHEEL LOADER

Model: 950F II WHEEL LOADER 8TK

Configuration: 950F Series II Wheel Loader 8TK00001-UP (MACHINE) POWERED BY 3116 Engine

## Disassembly and Assembly

### 446 and 446B Backhoe Loaders, Lexion 450 Combine, 3114 and 3116 Engines, IT18F Integrated Toolcarrier, D6M Track-Type Tractor and 928F, 950F and 950G Wheel Loaders

Media Number -SEN3611-18

Publication Date -01/05/2009

Date Updated -27/05/2009

i03706818

## Crankshaft Main Bearings - Remove

SMCS - 1203-011

### Removal Procedure

Table 1

Required Tools			
Tool	Part Number	Part Description	Qty
A	2P-5518	Bearing Tool	1

#### Start By:

- a. Remove the engine balancer shaft on 3114 engines. Refer to Disassembly and Assembly, "Engine Balancer Shaft - Remove and Install".
- b. Remove the engine oil pump. Refer to Disassembly and Assembly, "Engine Oil Pump - Remove".

---

### NOTICE

**Keep all parts clean from contaminants.**

**Contaminants may cause rapid wear and shortened component life.**

---

---

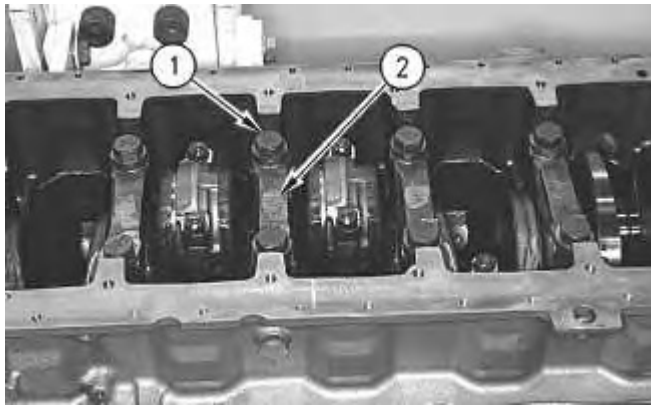

Illustration 1

g00610152

1. Remove bolts (1) that hold crankshaft main bearing cap (2). Remove crankshaft main bearing cap (2).
2. Remove the lower half of the crankshaft main bearing from crankshaft main bearing cap (2).

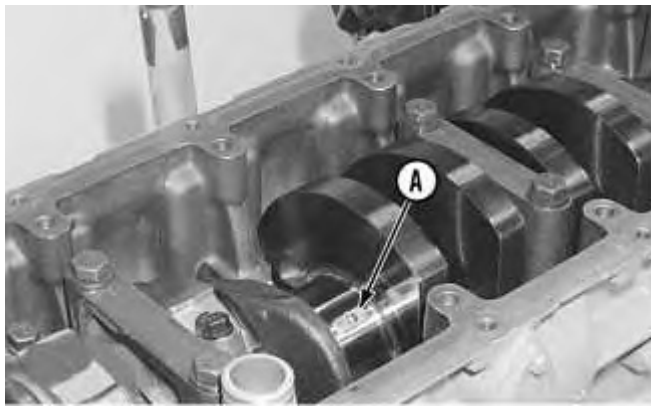

Illustration 2

g00516920

---

## NOTICE

**If the crankshaft is turned in the wrong direction, the tab of the crankshaft main bearing will be pushed between the crankshaft and the cylinder block. this can cause damage to either or both the crankshaft and the cylinder block.**

---

**Note:** Some crankshaft main bearing journals do not have an oil hole. Place a thin piece of soft material that will not damage the journal against the end of the bearing. Ensure that the material is on the opposite side of the bearing tab. Hit the bearing with the soft material until the bearing tab is free from the bearing tab groove in the cylinder block.

3. Use the following steps in order to remove the upper half of crankshaft main bearings:

- a. Turn the crankshaft until Tooling (A) can be installed in the crankshaft journal. Install Tooling (A).
  - b. Turn the crankshaft in order to remove the upper half of the crankshaft main bearing. In order to get the tab out first, the crankshaft must be turned in the correct direction.
  - c. Check the condition of the crankshaft main bearings. Refer to the Guideline For Reusable Parts, SEBF8009, "Main and Connecting Rod Bearings" and Guideline For Reusable Parts, SEBV0544, "Engine Bearings and Crankshafts".
-

Product: WHEEL LOADER

Model: 950F II WHEEL LOADER 8TK

Configuration: 950F Series II Wheel Loader 8TK00001-UP (MACHINE) POWERED BY 3116 Engine

## Disassembly and Assembly

**446 and 446B Backhoe Loaders, Lexion 450 Combine, 3114 and 3116 Engines, IT18F Integrated Toolcarrier, D6M Track-Type Tractor and 928F, 950F and 950G Wheel Loaders**

Media Number -SEN3611-18

Publication Date -01/05/2009

Date Updated -27/05/2009

i06542070

# Crankshaft Main Bearings - Install

SMCS - 1203-012

## Installation Procedure

Table 1

Required Tools			
Tool	Part Number	Part Description	Qty
A	2P-5518	Bearing Tool	1
B	8T-5096	Dial Indicator Group	1

---

### NOTICE

**Keep all parts clean from contaminants.**

**Contaminants may cause rapid wear and shortened component life.**

---

**Note:** For information on the reusability of the crankshaft main bearings, refer to the Guideline For Reusable Parts And Salvage Operations, SEBF8009, "Main and Connecting Rod Bearings".

**Note:** Place clean engine oil on the crankshaft main bearings prior to assembly. The tabs on the back side of the crankshaft main bearings must fit in the grooves of main bearing caps and the cylinder block.

---

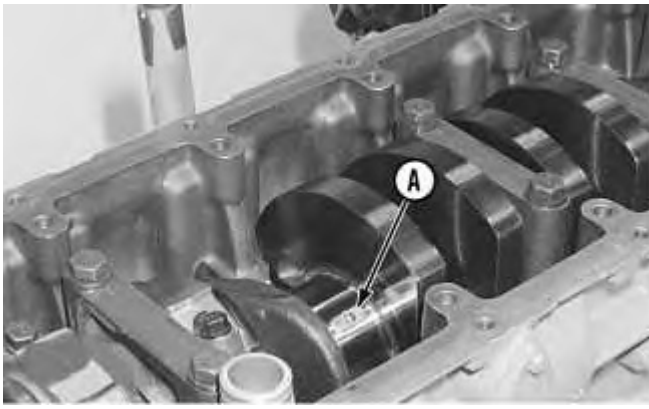

Illustration 1

g00516920

1. Use Tooling (A) and install the upper halves of the crankshaft main bearings in the cylinder block. Do not put oil on the back of the crankshaft main bearing.

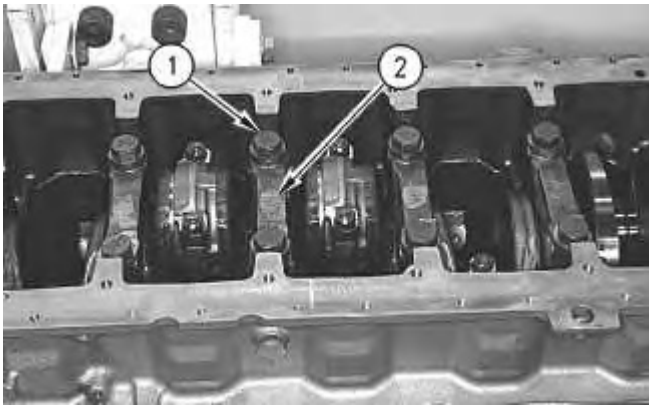
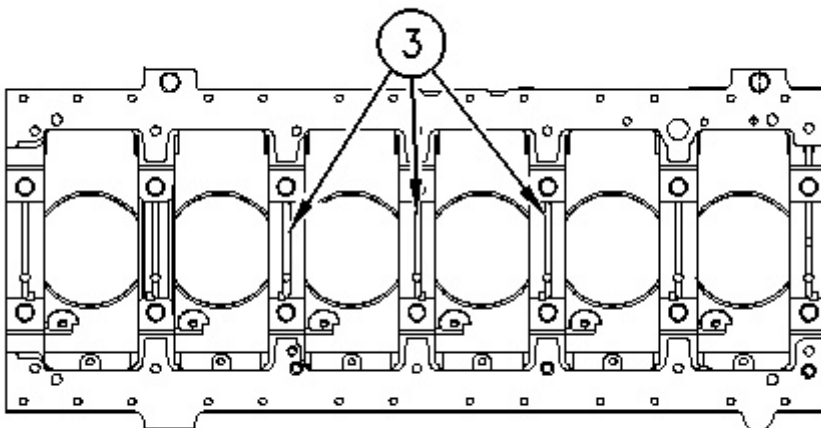

Illustration 2

g00610152

2. Install the lower halves of the crankshaft main bearings in crankshaft main bearing caps (2). Do not put oil on the back of the crankshaft main bearing.



Six-cylinder engine with oil grooves in the cylinder block

---

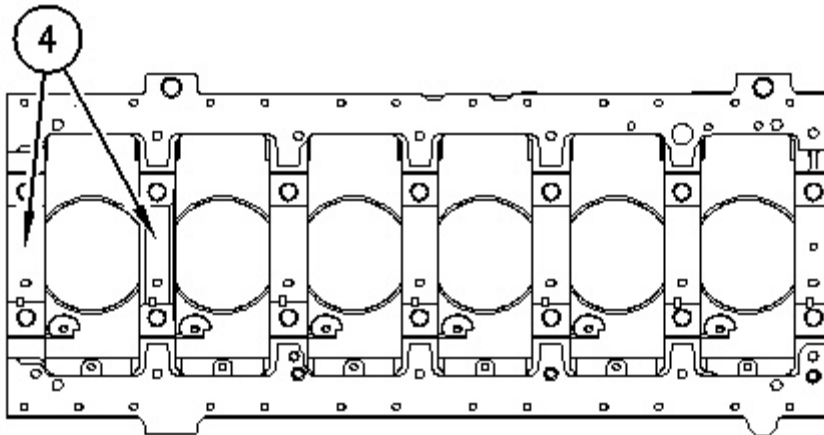

Illustration 4

g00639623

Six-cylinder engine with no oil grooves in the cylinder block

---

### NOTICE

**Crankshaft main bearing caps should be installed with the part number toward the right side of the engine. Crankshaft main bearing caps are to be identified by stamped numbers 1 through 7 located on the bottom surface. The thrust plate is to be installed in the original position on the crankshaft main bearing.**

---

- Oil grooves are machined in the saddles of the cylinder blocks of all 3114 engines and earlier 3116 engines. No oil grooves are machined in the saddles of the cylinder block on later 3116 engines and all 3126 engines.
  - Install the bearing caps with the bearing tabs on the same side. A six cylinder engine has an order of 1 through 7 (front to rear). A four cylinder engine has an order of 1 through 5 (front to rear). Place crankshaft main bearing caps (2) in position on the cylinder block. Place clean engine oil or Molylube on the bolt threads and the washer face. Install bolts (1).
  - Tighten bolts (1) to a torque of  $54 \pm 7$  N·m ( $40 \pm 5$  lb ft). Tighten each bolt (1) for an additional  $90 \pm 5$  degrees (1/4 turn).
-

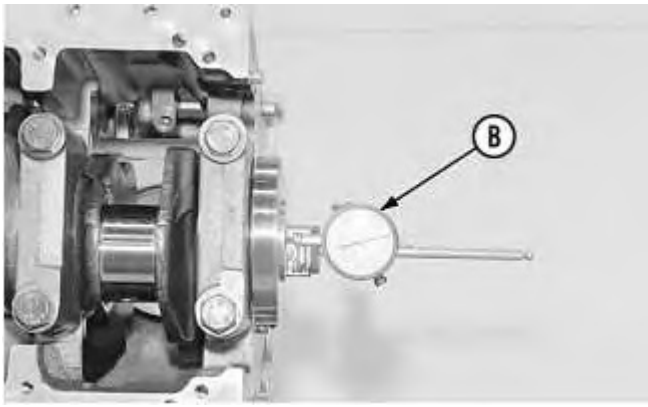

---

Illustration 5

g00517003

6. Check the end play of the crankshaft with Tooling (B). The end play must be 0.07 mm (0.003 inch) to 0.32 mm (0.013 inch).

**End By:**

- a. Install the engine oil pump. Refer to Disassembly and Assembly, "Engine Oil Pump - Install".
  - b. Install the engine balancer shaft on 3114 engines. Refer to Disassembly and Assembly, "Engine Balancer Shaft - Remove and Install".
-

Product: WHEEL LOADER

Model: 950F II WHEEL LOADER 8TK

Configuration: 950F Series II Wheel Loader 8TK00001-UP (MACHINE) POWERED BY 3116 Engine

## Disassembly and Assembly

### 446 and 446B Backhoe Loaders, Lexion 450 Combine, 3114 and 3116 Engines, IT18F Integrated Toolcarrier, D6M Track-Type Tractor and 928F, 950F and 950G Wheel Loaders

Media Number -SEN3611-18

Publication Date -01/05/2009

Date Updated -27/05/2009

i01935937

## Crankshaft - Remove

SMCS - 1202-011

### Removal Procedure

#### Start By:

- a. Remove the cylinder head. Refer to Disassembly and Assembly, "Cylinder Head - Remove".
- b. Remove the crankshaft seal carrier. Refer to Disassembly and Assembly, "Crankshaft Rear Seal Carrier - Remove and Install".
- c. Remove the front gear group. Refer to Disassembly and Assembly, "Gear Group (Front) - Remove".
- d. Remove the piston and the connecting rods. Refer to Disassembly and Assembly, "Piston and Connecting Rods-Remove".

---

#### NOTICE

**Keep all parts clean from contaminants.**

**Contaminants may cause rapid wear and shortened component life.**

---

---

#### NOTICE



**Care must be taken to ensure that fluids are contained during performance of inspection, maintenance, testing, adjusting, and repair of the product. Be prepared to collect the fluid with suitable containers before opening any compartment or disassembling any component containing fluids.**

**Refer to Special Publication, NENG2500, "Dealer Service Tool Catalog" for tools and supplies suitable to collect and contain fluids on Cat products.**

**Dispose of all fluids according to local regulations and mandates.**

---

**Note:** For information on reusability of the crankshaft, refer to the following list.

- Guideline For Reusable Parts And Salvage Operations, SEBF8041, "Crankshaft Measurement"
- Guideline For Reusable Parts And Salvage Operations, SEBF8054, "Procedure to Measure and Straighten Bent Crankshafts"
- Guideline For Reusable Parts And Salvage Operations, SEBF8094, "Procedure to Grind Crankshafts"
- Guideline For Reusable Parts And Salvage Operations, SEBF8043, "Visual Inspection of Crankshafts"
- Guideline For Reusable Parts And Salvage Operations, SEBF8039, "Inspection of Crankshafts for Cracks"
- Guideline For Reusable Parts And Salvage Operations, SEBF8042, "Procedure to Polish Crankshafts"

**Note:** For information on reusability of the crankshaft main bearings, refer to Guideline For Reusable Parts And Salvage Operations, SEBF8009, "Main and Connecting Rod Bearings".

**Note:** For information on reusability of the cylinder block and salvage procedures, refer to the following list.

- Guideline For Reusable Parts And Salvage Operations, SEBF8192, "Specifications and Salvage for Cylinder Blocks on 3114, 3116, and 3126 Engines"
- Guideline For Reusable Parts And Salvage Operations, SEBF8261, "Installing a 7C-6208 Cylinder Sleeve in 3114, 3116 Engines and a 107-7604 Cylinder Sleeve in 3126 Engines"
- Special Instruction, SEHS8869, "Cylinder Block Salvage Procedure Using Belzona Ceramic R Metal"
- Special Instruction, GMG00981, "Using 1P-3537 Dial Bore Gauge Group to Check Cylinder Bore Size"
- Special Instruction, SMHS7606, " Use of 1P-4000 Line Boring Tool Group"
- Special Instruction, SEHS8841, " Using the Ironstitch Procedure for Casting Salvage"

- Special Instruction, SEHS8919, "Salvage Weld Procedure for Cast Iron Cylinder Blocks"
- Guideline For Reusable Parts And Salvage Operations, SEBF8076, "Specifications to Salvage Cylinder Block Contact Surfaces"

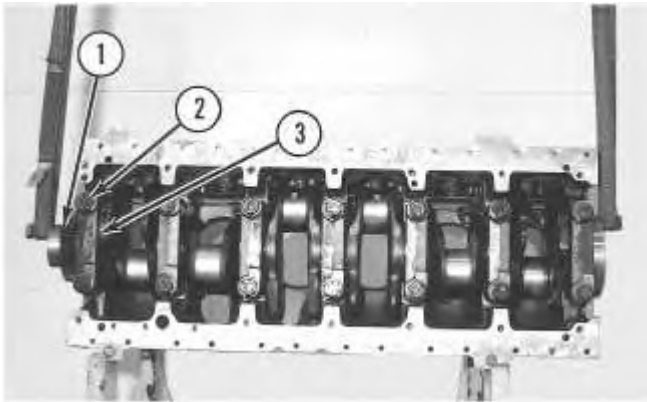

Illustration 1

g00625767

**Note:** The weight of the crankshaft for the 3114 Engine is 37 kg (82 lb). The weight of the crankshaft for 3116 and 3126 Engines is 62 kg (137 lb).

1. Use a suitable lifting device. Remove bolts (2), the washers and main bearing caps (3). Carefully remove crankshaft (1) from the cylinder block.



Illustration 2

g00625782

2. Remove upper main bearing (4) from the cylinder block.
  3. Remove the main bearings from the main bearing caps.
-

Product: WHEEL LOADER

Model: 950F II WHEEL LOADER 8TK

Configuration: 950F Series II Wheel Loader 8TK00001-UP (MACHINE) POWERED BY 3116 Engine

## Disassembly and Assembly

**446 and 446B Backhoe Loaders, Lexion 450 Combine, 3114 and 3116 Engines, IT18F Integrated Toolcarrier, D6M Track-Type Tractor and 928F, 950F and 950G Wheel Loaders**

Media Number -SEN3611-18

Publication Date -01/05/2009

Date Updated -27/05/2009

i06249742

## Crankshaft - Install

SMCS - 1202-012

## Installation Procedure

Table 1

Required Tools			
Tool	Part Number	Part Description	Qty
A	8T-5096	Dial Indicator Group	1

---

### NOTICE

**Keep all parts clean from contaminants.**

**Contaminants may cause rapid wear and shortened component life.**

---

### NOTICE

**Ensure that the crankshaft main bearing tabs engage with the grooves in the block and the crankshaft main bearing cap.**

---

**Note:** For information on reusability of the crankshaft, refer to the following list.

- Guideline For Reusable Parts And Salvage Operations, SEBF8041, "Crankshaft Measurement"
- Guideline For Reusable Parts And Salvage Operations, SEBF8054, "Procedure to Measure and Straighten Bent Crankshafts"
- Guideline For Reusable Parts And Salvage Operations, SEBF8094, "Procedure to Grind Crankshafts"
- Guideline For Reusable Parts And Salvage Operations, SEBF8043, "Visual Inspection of Crankshafts"
- Guideline For Reusable Parts And Salvage Operations, SEBF8039, "Inspection of Crankshafts for Cracks"
- Guideline For Reusable Parts And Salvage Operations, SEBF8042, "Procedure to Polish Crankshafts"

**Note:** For information on reusability of the cylinder block and salvage procedures, refer to the following list.

- Guideline For Reusable Parts And Salvage Operations, SEBF8192, "Specifications and Salvage for Cylinder Blocks on 3114, 3116, and 3126 Engines"
  - Guideline For Reusable Parts And Salvage Operations, SEBF8261, "Installing a 7C-6208 Cylinder Sleeve in 3114, 3116 Engines and a 107-7604 Cylinder Sleeve in 3126 Engines"
  - Special Instruction, SEHS8869, "Cylinder Block Salvage Procedure Using Belzona Ceramic R Metal"
  - Special Instruction, GMG00981, "Using 1P-3537 Dial Bore Gauge Group to Check Cylinder Bore Size"
  - Special Instruction, SMHS7606, " Use of 1P-4000 Line Boring Tool Group"
  - Special Instruction, SEHS8841, " Using the Ironstitch Procedure for Casting Salvage"
  - Special Instruction, SEHS8919, "Salvage Weld Procedure for Cast Iron Cylinder Blocks"
  - Guideline For Reusable Parts And Salvage Operations, SEBF8076, "Specifications to Salvage Cylinder Block Contact Surfaces"
1. Check the condition of the crankshaft main bearings. Refer to the Guideline For Reusable Parts, SEBF8009, "Main and Connecting Rod Bearings" and Guideline For Reusable Parts, SEBV0544, "Engine Bearings and Crankshafts".

**Note:** The number four main bearing in 3114 Engines is the thrust bearing. The number six main bearing in the six cylinder engines is the thrust bearing.

2. Clean the bearing surfaces in the cylinder block for the main bearings.
-

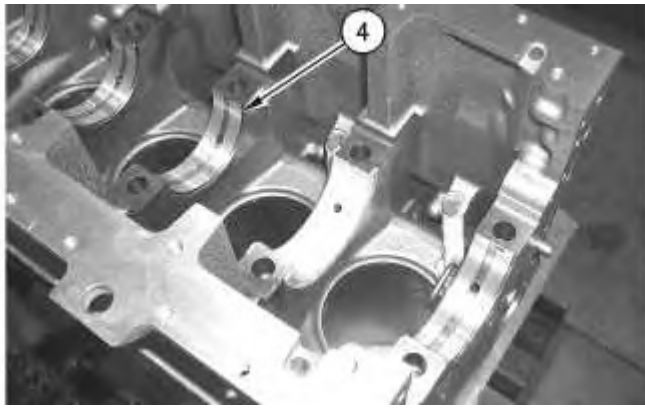

---

Illustration 1

g00678393

3. Install the upper main bearings (4) in the cylinder block. Ensure that the tab on the back side of the bearing engages with the groove in the cylinder block. Apply clean engine oil on the upper main bearing. Do not put engine oil on the back side of the bearing surfaces.

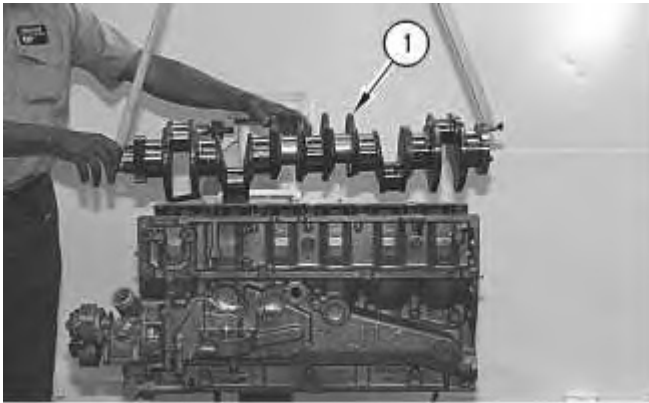

---

Illustration 2

g00610100

Typical example

4. Put clean engine oil on the journals of the crankshaft bearing. Fasten lifting straps and a hoist to crankshaft (1) . Carefully install the crankshaft in the cylinder block.
  5. Clean the bearing surface of the main bearing caps.
-



Illustration 3

g00678394

6. Install the lower main bearings (5) in the crankshaft main bearing caps (3) . Ensure that the tab on the back side of the bearing engages with the groove in the main bearing cap. Apply clean engine oil on the lower main bearing. Do not put engine oil on the back side of the bearing surfaces.
7. Install crankshaft main bearing caps with the bearing tabs on the same side. Ensure that crankshaft main bearing caps have numbers 1 through 7. The numbers should start at the front of the engine. Place clean engine oil or Molylube on the bolt threads and the washers.

**Note:** When the bolts for the rear main bearing cap are tightened, slide the main bearing cap as far forward as possible until the cap is against the bolts. Hold the main bearing cap in this position and tighten the bolts.

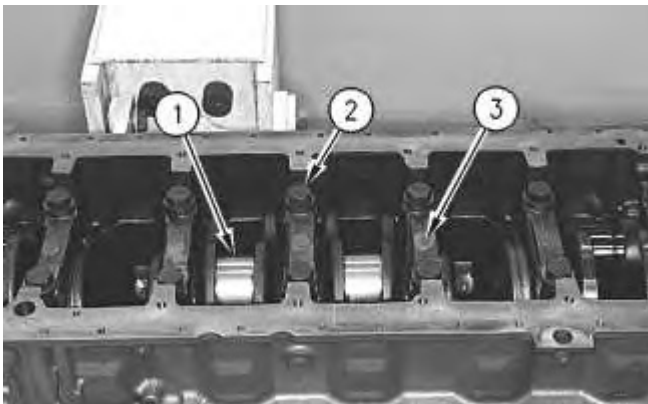
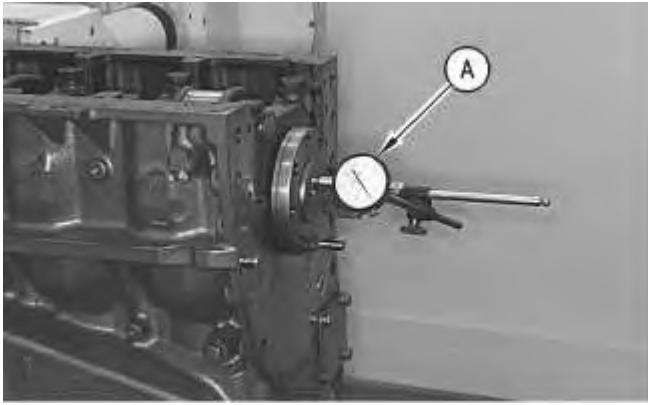

Illustration 4

g00609985

Typical example

8. Install bolts (2) and the washers for main bearing caps (3) . Tighten bolts (2) to a torque of  $54 \pm 7$  N·m ( $40 \pm 5$  lb ft).
9. Turn bolts (2) for an additional  $90 \pm 5$  degrees ( $1/4$  turn).



---

Illustration 5

g00610119

Typical example

10. Check the end play of crankshaft (1) with Tooling (A) . The end play must be 0.07 mm (0.003 inch) to 0.32 mm (0.013 inch).

**End By:**

- a. Install the pistons and connecting rods. Refer to Disassembly and Assembly, "Pistons and Connecting Rods - Install".
  - b. Install the front gear group. Refer to Disassembly and Assembly, "Gear Group (Front) - Install".
  - c. Install the crankshaft seal carrier. Refer to Disassembly and Assembly, "Crankshaft Rear Seal Carrier- Remove and Install".
  - d. Install the cylinder head. Refer to Disassembly and Assembly, "Cylinder Head - Install".
-

Product: WHEEL LOADER

Model: 950F II WHEEL LOADER 8TK

Configuration: 950F Series II Wheel Loader 8TK00001-UP (MACHINE) POWERED BY 3116 Engine

## **Disassembly and Assembly**

**446 and 446B Backhoe Loaders, Lexion 450 Combine, 3114 and 3116 Engines, IT18F Integrated Toolcarrier, D6M Track-Type Tractor and 928F, 950F and 950G Wheel Loaders**

Media Number -SEN3611-18

Publication Date -01/05/2009

Date Updated -27/05/2009

i01944203

# **Crankshaft Gear - Remove and Install**

SMCS - 1204-010-GE

## **Removal Procedure**

### **Start By:**

- a. Remove the front gear group. Refer to Disassembly and Assembly, "Gear Group (Front) - Remove".

---

### **NOTICE**

**Keep all parts clean from contaminants.**

**Contaminants may cause rapid wear and shortened component life.**

---

**Note:** For information on reusability of the camshaft gear, refer to Guideline For Reusable Parts And Salvage Operations, SEBF8045, "Timing Gears for All Engines".

1. Place alignment marks on the crankshaft gear and on the crankshaft. The alignment marks will ensure that the camshaft gear is aligned properly during installation.
-



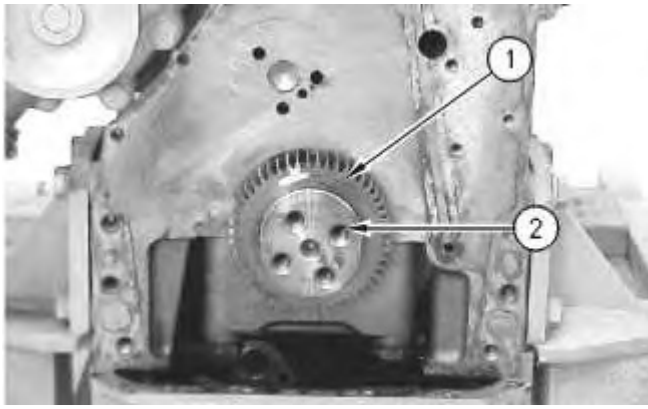

Illustration 1

g00630476

2. Heat crankshaft gear (1). Remove crankshaft gear (1) from crankshaft (2).

## Installation Procedure

---

### NOTICE

**Keep all parts clean from contaminants.**

**Contaminants may cause rapid wear and shortened component life.**

---

**Note:** For information on reusability of the camshaft gear, refer to Guideline For Reusable Parts And Salvage Operations, SEBF8045, "Timing Gears for All Engines".

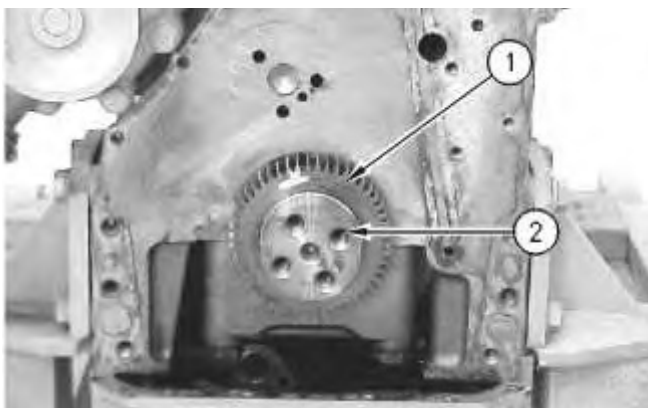

Illustration 2

g00630476

1. Heat crankshaft gear (1) to a maximum temperature of 204 °C (400 °F) for no longer than 1 hour for installation.
2. Align the timing marks on the crankshaft and on crankshaft gear (1). Install crankshaft gear (1) on crankshaft (2).

**Note:** Ensure that crankshaft gear (1) is flush against the shoulder of crankshaft. If the gear is not flush damage to the gear may occur.

**End By:**

- a. Install the front gear group. Refer to Disassembly and Assembly, "Gear Group (Front) - Install".
-

Product: WHEEL LOADER

Model: 950F II WHEEL LOADER 8TK

Configuration: 950F Series II Wheel Loader 8TK00001-UP (MACHINE) POWERED BY 3116 Engine

## Disassembly and Assembly

### 446 and 446B Backhoe Loaders, Lexion 450 Combine, 3114 and 3116 Engines, IT18F Integrated Toolcarrier, D6M Track-Type Tractor and 928F, 950F and 950G Wheel Loaders

Media Number -SEN3611-18

Publication Date -01/05/2009

Date Updated -27/05/2009

i05977048

## Bearing Clearance - Check

SMCS - 1203-535; 1219-535

## Measurement Procedure

Table 1

Required Tools			
Tool	Part Number	Part Description	Qty
A	198-9142	Plastic Gauge (Green) 0.025 to 0.076 mm (0.001 to 0.003 inch)	1
	198-9143	Plastic Gauge (Red) 0.051 to 0.152 mm (0.002 to 0.006 inch)	1
	198-9144	Plastic Gauge (Blue) 0.102 to 0.229 mm (0.004 to 0.009 inch)	1
	198-9145	Plastic Gauge (Yellow) 0.230 to 0.510 mm (0.009 to 0.020 inch)	1

**Note:** Plastic gauge may not be necessary when the engine is in the chassis.

---

## NOTICE

**Keep all parts clean from contaminants.**

## **Contaminants may cause rapid wear and shortened component life.**

---

**Note:** Cat does not recommend the checking of the actual bearing clearances particularly on small engines. This is because of the possibility of obtaining inaccurate results and the possibility of damaging the bearing or the journal surfaces. Each Cat engine bearing is quality checked for specific wall thickness.

**Note:** The measurements should be within specifications and the correct bearings should be used. If the crankshaft journals and the bores for the block and the rods were measured during disassembly, no further checks are necessary. However, if the technician still wants to measure the bearing clearances, Tooling (A) is an acceptable method. Tooling (A) is less accurate on journals with small diameters if clearances are less than 0.10 mm (0.004 inch).

---

### **NOTICE**

**Lead wire, shim stock or a dial bore gauge can damage the bearing surfaces.**

---

The technician must be very careful to use Tooling (A) correctly. The following points must be remembered:

- Ensure that the backs of the bearings and the bores are clean and dry.
- Ensure that the bearing locking tabs are properly seated in the tab grooves.
- The crankshaft must be free of oil at the contact points of Tooling (A).

1. Put a piece of Tooling (A) on the crown of the bearing that is in the cap.

**Note:** Do not allow Tooling (A) to extend over the edge of the bearing.

2. Use the correct torque-turn specifications in order to install the bearing cap. Do not use an impact wrench. Be careful not to dislodge the bearing when the cap is installed.

**Note:** Do not turn the crankshaft when Tooling (A) is installed.

3. Carefully remove the cap, but do not remove Tooling (A). Measure the width of Tooling (A) while Tooling (A) is in the bearing cap or on the crankshaft journal. Refer to Illustration 1.

---

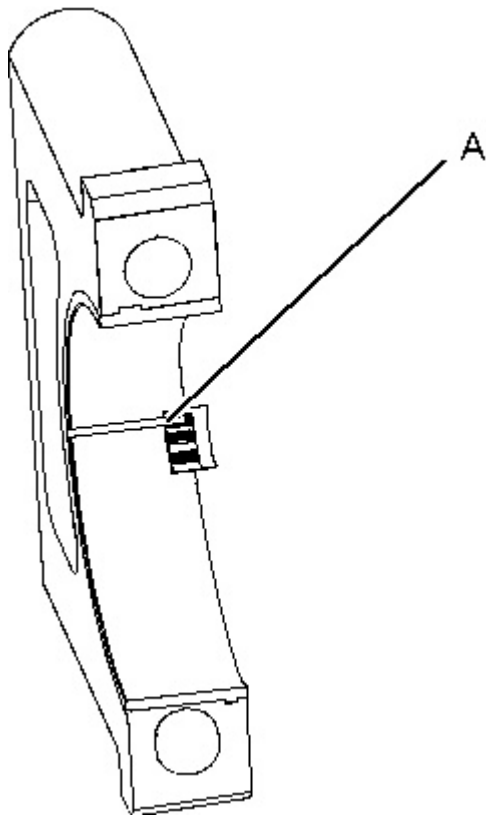

---

Illustration 1  
Typical Example

g01152855

4. Remove all of Tooling (A) before you install the bearing cap.

**Note:** When Tooling (A) is used, the readings can sometimes be unclear. For example, all parts of Tooling (A) are not the same width. Measure the major width in order to ensure that the parts are within the specification range. Refer to Specifications Manual, "Connecting Rod Bearing Journal" and Specifications Manual, "Main Bearing Journal" for the correct clearances.

---

Product: WHEEL LOADER

Model: 950F II WHEEL LOADER 8TK

Configuration: 950F Series II Wheel Loader 8TK00001-UP (MACHINE) POWERED BY 3116 Engine

## **Disassembly and Assembly**

**446 and 446B Backhoe Loaders, Lexion 450 Combine, 3114 and 3116 Engines, IT18F Integrated Toolcarrier, D6M Track-Type Tractor and 928F, 950F and 950G Wheel Loaders**

Media Number -SEN3611-18

Publication Date -01/05/2009

Date Updated -27/05/2009

i01931368

# **Engine Oil Pressure Sensor - Remove and Install**

SMCS - 1924-010

## **Removal Procedure**

---

### **NOTICE**

**Care must be taken to ensure that fluids are contained during performance of inspection, maintenance, testing, adjusting, and repair of the product. Be prepared to collect the fluid with suitable containers before opening any compartment or disassembling any component containing fluids.**

**Refer to Special Publication, NENG2500, "Dealer Service Tool Catalog" for tools and supplies suitable to collect and contain fluids on Cat products.**

**Dispose of all fluids according to local regulations and mandates.**



**WARNING**

**At operating temperature, the engine coolant is hot and under pressure.**

**Steam can cause personal injury.**

**Check the coolant level only after the engine has been stopped and the filler cap is cool enough to touch with the bare hand.**

Thank you so much for reading.  
Please click the “Buy Now!”  
button below to download the  
complete manual.



After you pay.

You can download the most  
perfect and complete manual in  
the world immediately.

Our support email:

[ebooklibonline@outlook.com](mailto:ebooklibonline@outlook.com)