

Product: WHEEL LOADER

Model: 950G II WHEEL LOADER AYB

Configuration: 950G II Wheel Loader AYB00001-UP (MACHINE) POWERED BY 3126B Engine

Disassembly and Assembly 950G Series II and 962G Series II Wheel Loaders and IT62G Series II Integrated Toolcarrier Power Train

Media Number -REN4311-04

Publication Date -01/12/2004

Date Updated -09/12/2004

i05754103

Torque Converter - Disassemble

SMCS - 3101-015

Disassembly Procedure

Table 1

Required Tools			
Tool	Part Number	Part Description	Qty
A	439-3940	Link Bracket	3
B	1P-7405	Eyebolt	2
C	2P-8312	Retaining Ring Pliers	1

Start By:

- A. Separate the torque converter from the transmission and from the output gears. Refer to Disassembly and Assembly, "Torque Converter from Transmission, Output Gears - Separate".
-

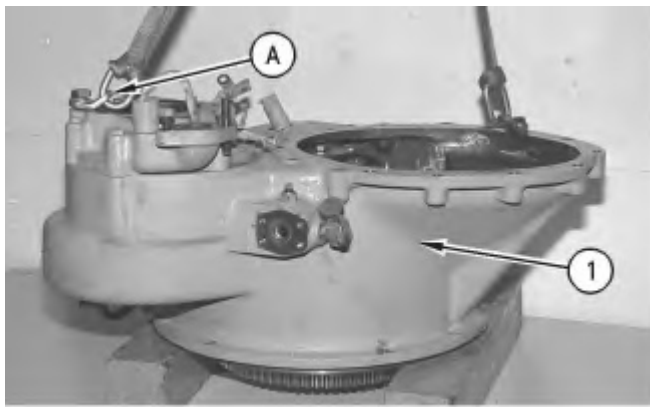

Illustration 1

g00319444

1. Use Tooling (A) and a suitable lifting device to place torque converter housing (1) onto suitable cribbing, as shown.

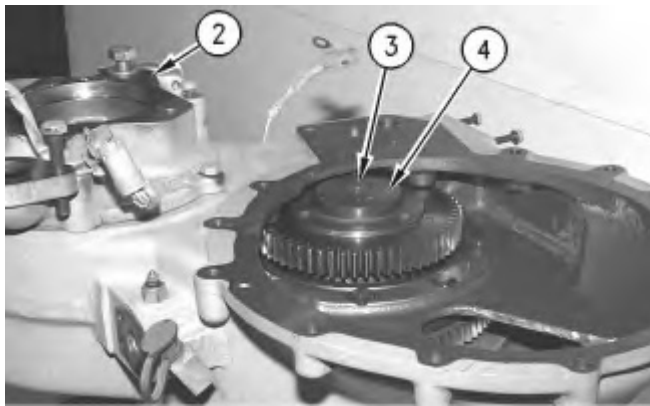
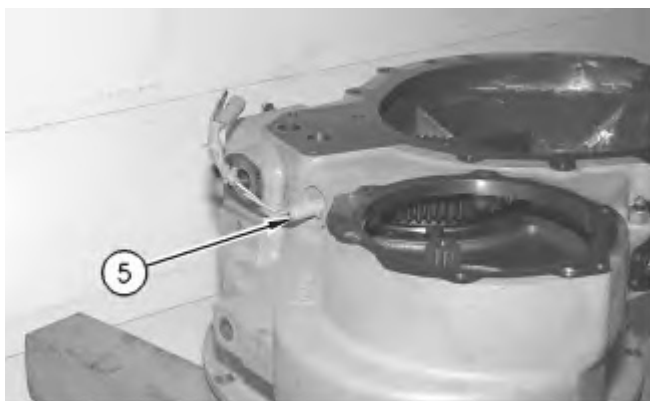

Illustration 2

g00319445

2. Remove transmission oil pump (2) . Refer to Disassembly and Assembly, "Transmission Oil Pump - Remove".
3. Remove bolt (3) and washer (4) .



4. Remove torque converter speed sensor (5) .



Illustration 4

5. Remove bolts (6) that hold the torque converter to the torque converter housing.

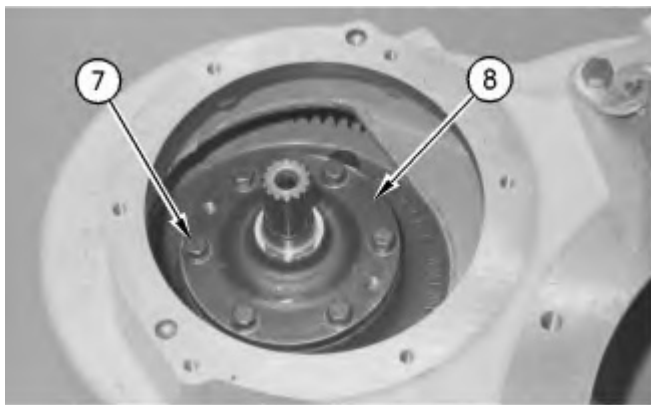

Illustration 5

6. Remove bolts (7) and pump drive flange (8) .
-

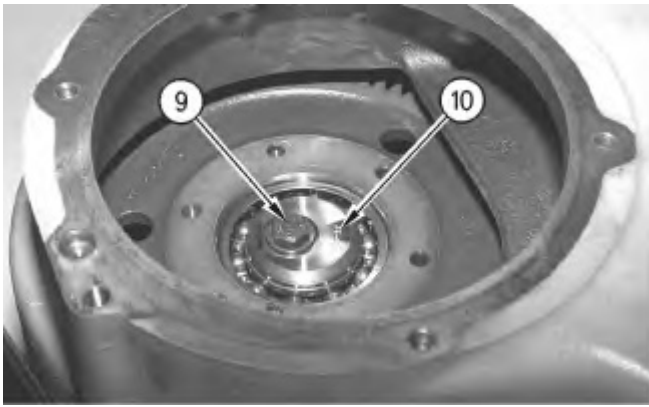

Illustration 6

g00319450

7. Remove bolt (9) that holds shaft (10) to the torque converter housing.

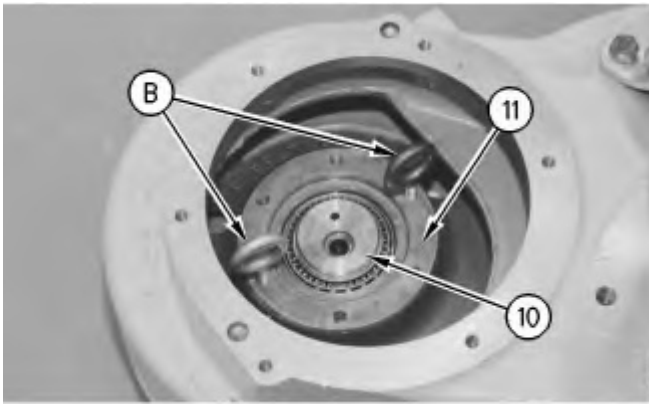

Illustration 7

g00319451

8. Install Tooling (B) in pump drive gear (11) .
9. Lift pump drive gear (11) and drive gear shaft (10) . Lift drive gear shaft (10) out of the torque converter housing bore.
10. Place the assembly to one side of the torque converter housing bore. Make sure that drive gear shaft (10) is not in the torque converter housing bore.

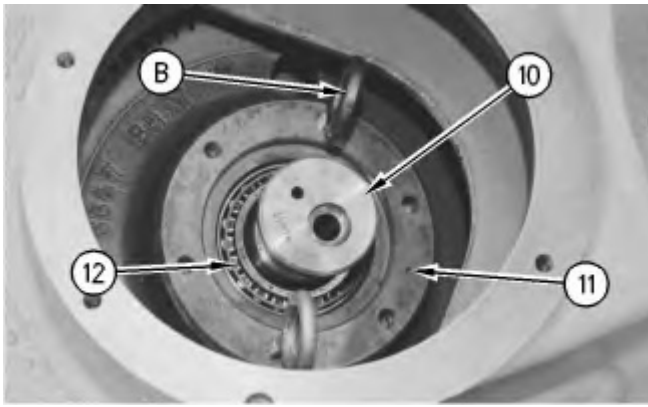

Illustration 8

g00319453

11. Remove Tooling (B) from pump drive gear (11) .
12. Remove drive gear shaft (10) from pump drive gear (11) .
13. Remove bearing (12) from pump drive gear (11) .



Illustration 9

g03652939

14. Use Tooling (A) and a suitable lifting device to remove torque converter housing (1) . The weight of torque converter housing (1) is approximately 113 kg (250 lb).
-



Illustration 10

g03652860

15. Turn torque converter housing (1) over to remove pump drive gear (11) .

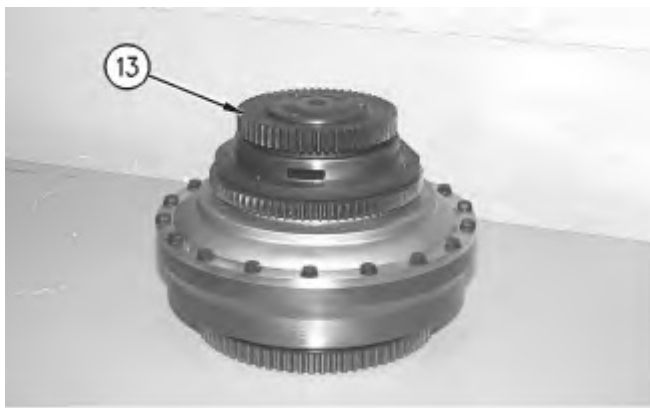

Illustration 11

g00319455

16. Remove drive gear (13) .

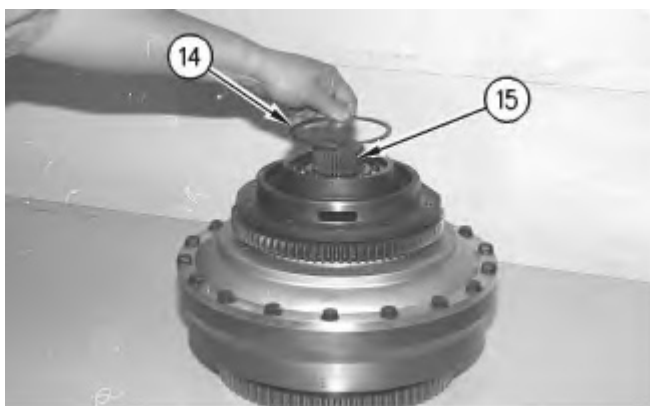

Illustration 12

g00319456

17. Remove retaining ring (14) that holds output shaft (15) .

18. Use a soft faced hammer in order to free the bearing from the carrier assembly. Remove output shaft (15) from the carrier assembly.

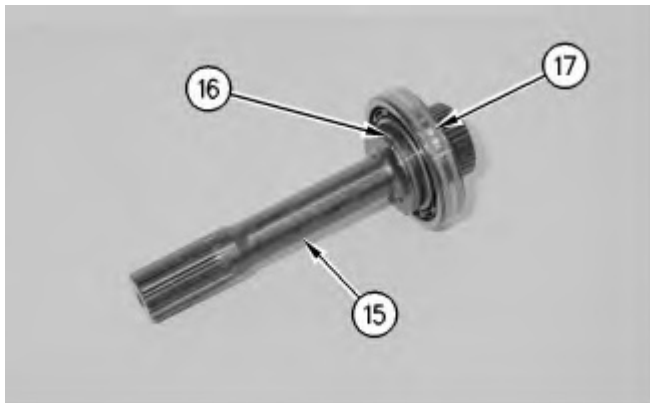

Illustration 13

g00319500

19. Remove seal ring (16) from output shaft (15) .
20. Use a suitable press to remove roller bearing (17) .



Illustration 14

g00319458

21. Remove bolts (18) . Remove torque converter impeller (19) from the impeller housing.

Note: If the torque converter is equipped with a freewheel stator, continue with Steps 22 through 28.

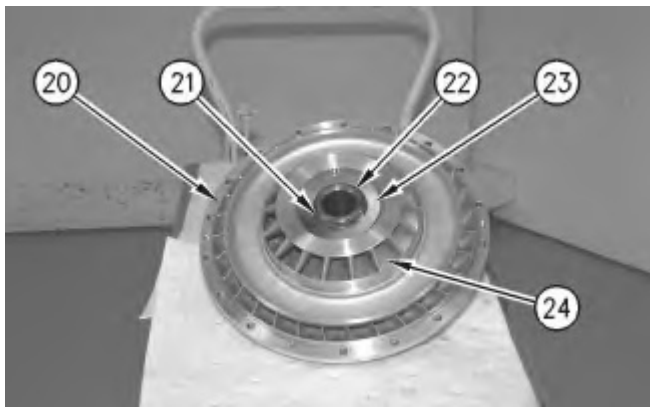

Illustration 15

g00877132

- 22. Turn impeller (20) to the opposite side.
- 23. Remove retaining ring (21) and spacer (22) from carrier shaft (23) .
- 24. Remove stator (24) .

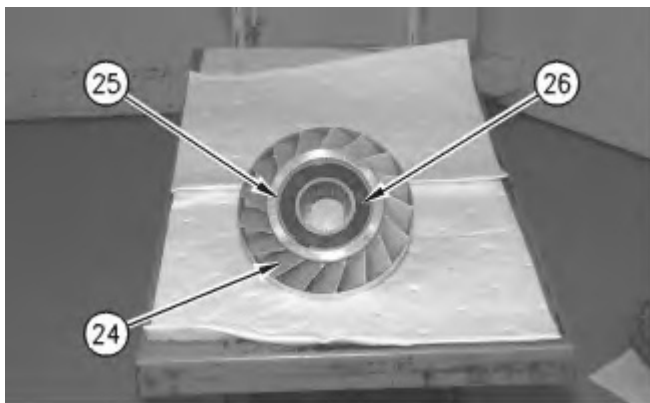

Illustration 16

g00877125

- 25. Remove retaining ring (25) and washer (26) from stator (24) . Repeat the procedure for the opposite side of stator (24) .
-

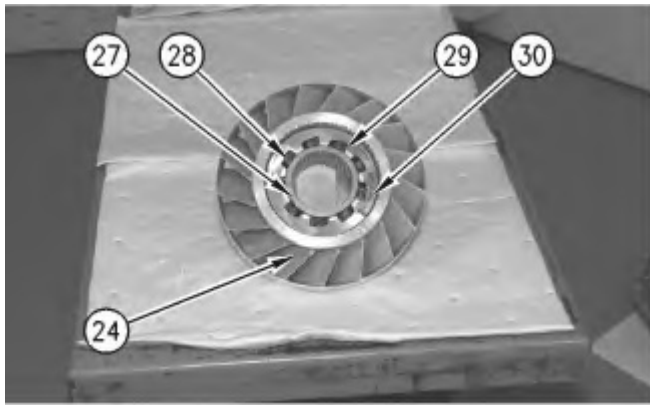

Illustration 17

g00877126

Note: If necessary, Raise the temperature of the stator to a maximum temperature of 135 °C (275 °F) for approximately 15 minutes.

26. Remove bearing race (27) , freewheel rollers (28) , freewheel springs (29) , and freewheel cam (30) from stator (24) .

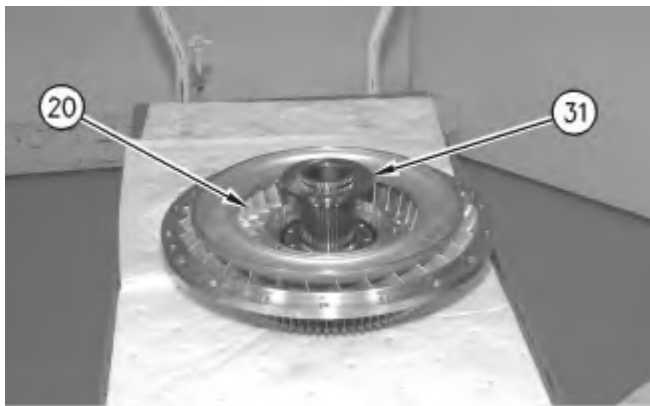
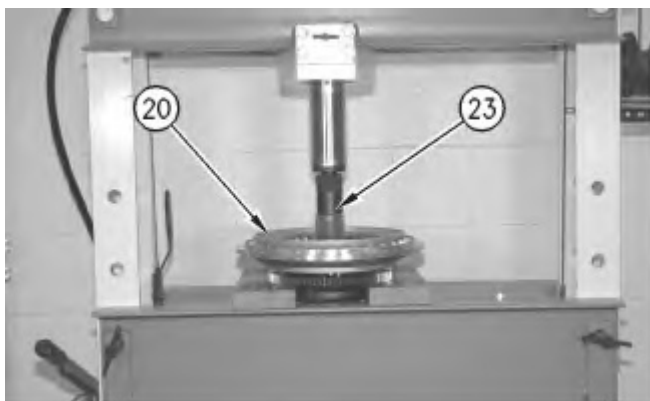

Illustration 18

g00877129

27. Remove spacer (31) from impeller (20) .



28. Use a press to remove carrier shaft (23) from impeller (20) .



Illustration 20

29. Remove bolts (32) and drive gear (33) from the torque converter impeller.

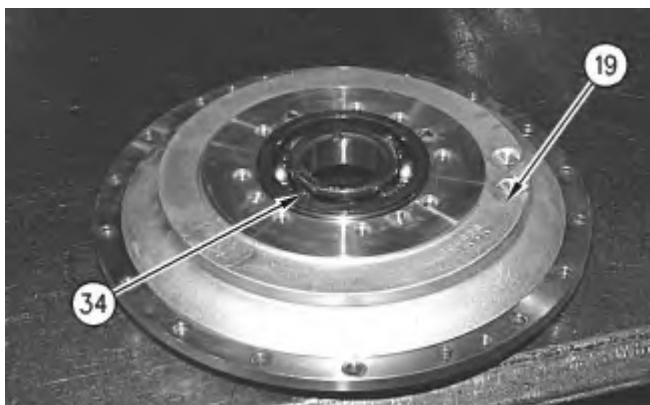

Illustration 21

30. Remove roller bearing (34) from torque converter impeller (19) .
-

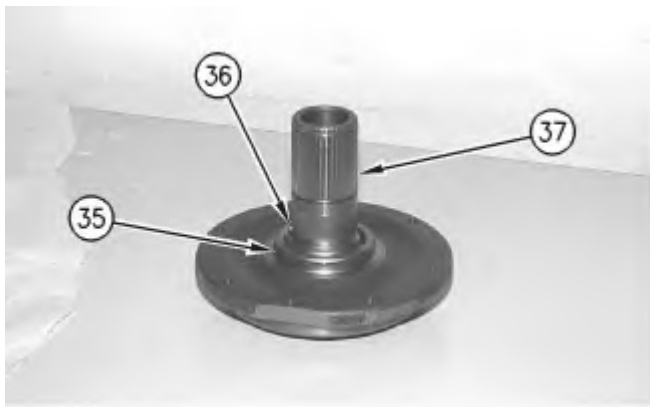

Illustration 22

g00877258

31. Remove seal ring (36) from carrier assembly (35) .

32. If necessary, remove locating dowel (37) .

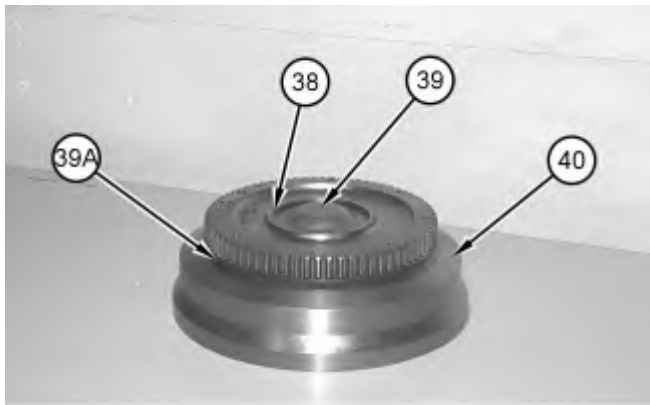

Illustration 23

g01146281

33. Remove ring (39A) . Remove retaining ring (38) and impeller cover (39) from impeller housing (40) .



34. Use Tooling (C) in order to remove retaining ring (41) .

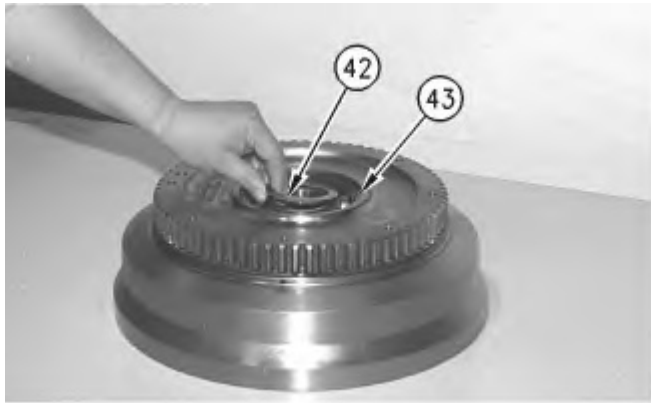

Illustration 25

g00877262

35. Remove bearing spacer (42) .
36. Remove O-ring seal (43) .

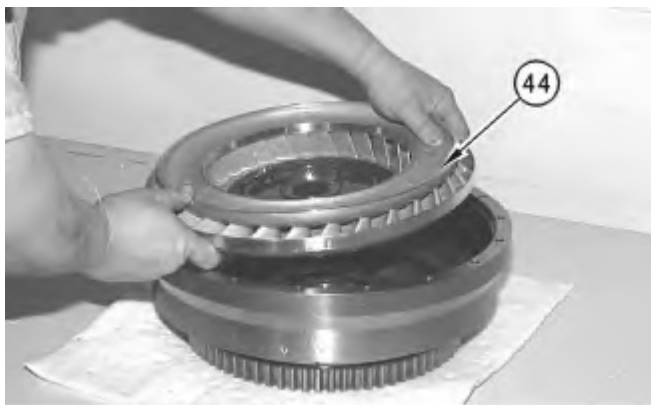

Illustration 26

g00877263

37. Turn the impeller housing onto the opposite side. Remove turbine assembly (44) .
-

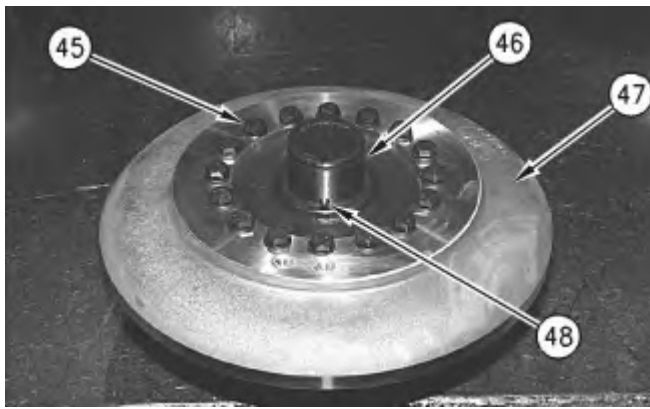

Illustration 27

g00877264

38. Remove bolts (45) . Separate turbine (46) from turbine hub assembly (47) .

39. If necessary, remove locating dowel (48) .

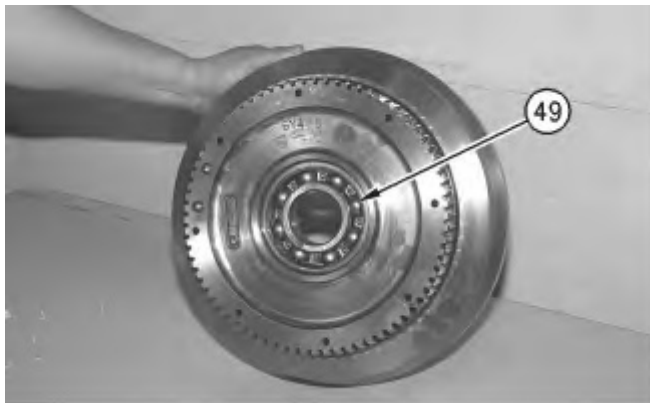

Illustration 28

g00877265

40. Remove roller bearing (49) from the impeller housing.

Product: WHEEL LOADER

Model: 950G II WHEEL LOADER AYB

Configuration: 950G II Wheel Loader AYB00001-UP (MACHINE) POWERED BY 3126B Engine

Disassembly and Assembly 950G Series II and 962G Series II Wheel Loaders and IT62G Series II Integrated Toolcarrier Power Train

Media Number -REN4311-04

Publication Date -01/12/2004

Date Updated -09/12/2004

i05754104

Torque Converter - Assemble

SMCS - 3101-016

Assembly Procedure

Table 1

Required Tools			
Tool	Part Number	Part Description	Qty
A	439-3940	Link Bracket	3
B	1P-7405	Eyebolt	2
C	2P-8312	Pliers	1
D	-	Loctite 536	-



Illustration 1

g00877265

Note: The notch on roller bearing (49) must be aligned with locating dowel (48) .

1. Install roller bearing (49) .

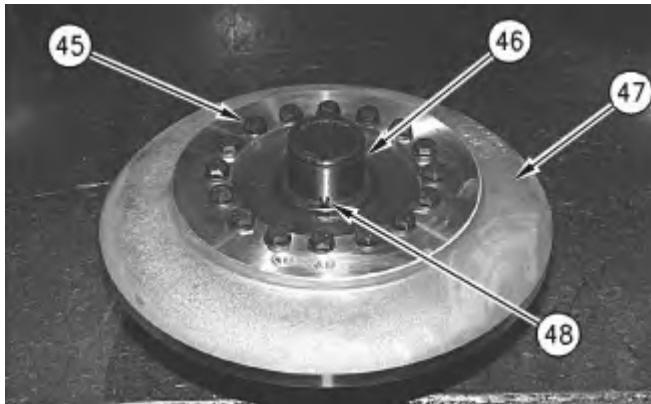

Illustration 2

g00877264

2. Install locating dowel (48) in turbine hub assembly (38) .
3. Install turbine hub assembly (47) to turbine (46) . Install bolts (45) . The torque for bolts (45) is 60 ± 7 N·m (44 ± 5 lb ft).

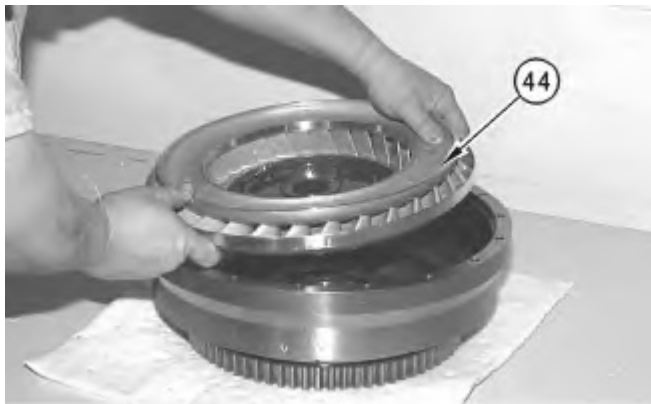

Illustration 3

g00877263

4. Install the impeller housing over turbine assembly (44) , as shown.
-

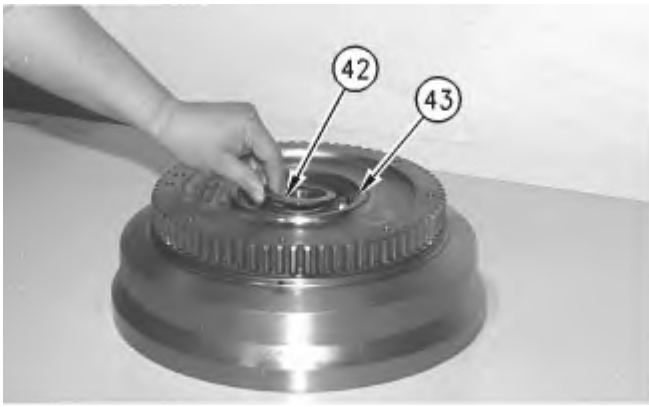

Illustration 4

g00877262

5. Install O-ring seal (43) .
6. Install bearing spacer (42) .

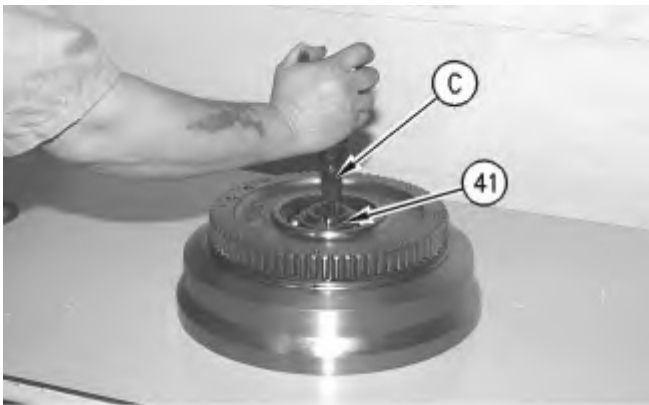

Illustration 5

g00877261

7. Use Tooling (C) in order to install retaining ring (41) .

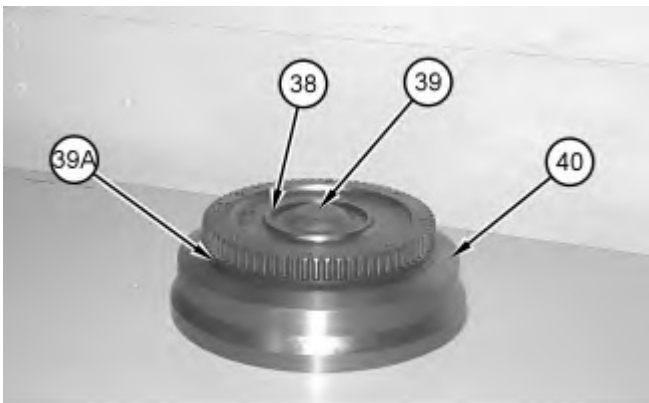

Illustration 6

g01146281

8. Install impeller cover (39) and retaining ring (38) in impeller housing (40) . Install ring (39A) .

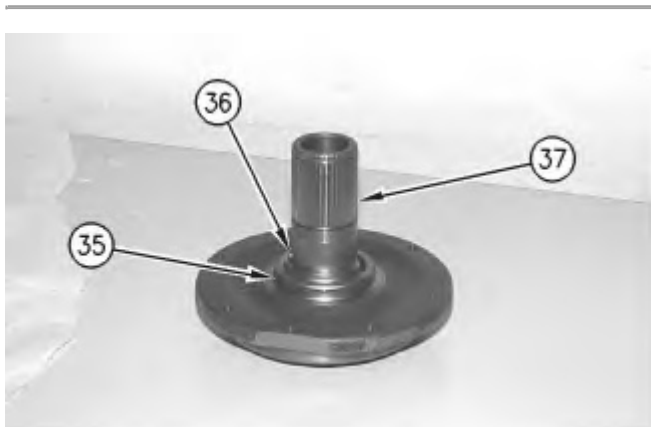

Illustration 7

g00877258

9. Install locating dowel (37) .
10. Install seal ring (36) on carrier assembly (35) .



Illustration 8

g00877257

Note: The notch in roller bearing (34) must be facing upward.

11. Install roller bearing (34) in torque converter impeller (19) .
-



Illustration 9

g00877250

12. Install drive gear (33) and bolts (32) on the torque converter impeller. The torque for bolts (32) is $105 \pm 15 \text{ N}\cdot\text{m}$ ($75 \pm 11 \text{ lb ft}$).

Note: If the torque converter is equipped with a freewheel stator, continue with Steps 13 through 18.

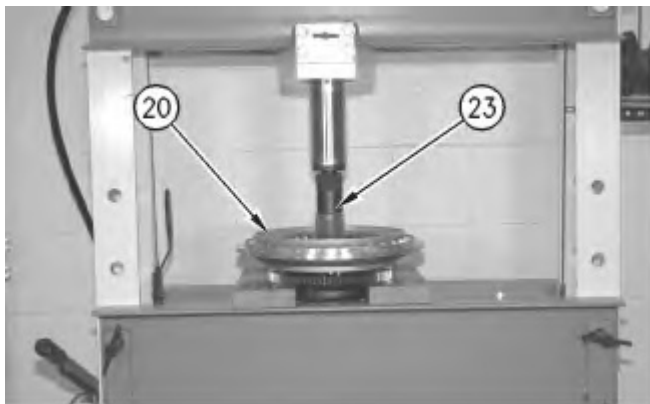
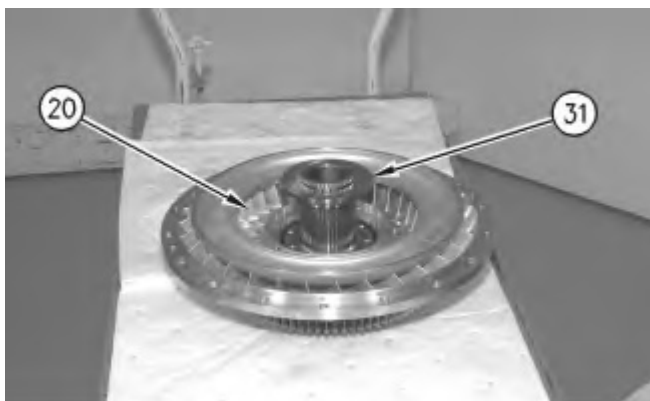

Illustration 10

g00877133

13. Use a suitable press to install carrier shaft (23) in impeller (20) .



14. Install spacer (31) on impeller (20) .

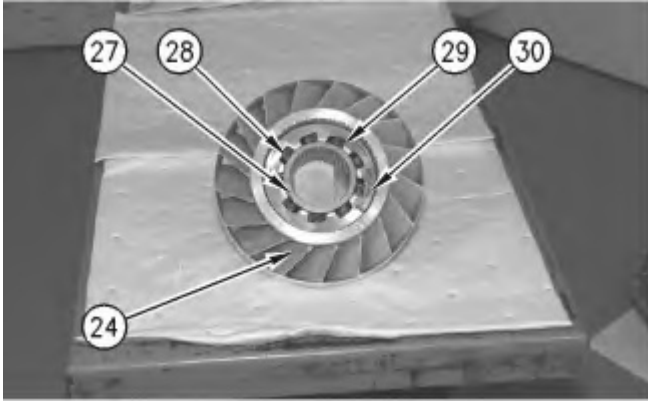

Illustration 12

g00877126

Note: If necessary, Raise the temperature of stator (24) to a maximum temperature of 135 ° C (275 °F). Install the cam with the IMPELLER SIDE facing downward. Continue with the installation until freewheel cam (30) contacts the retaining ring (not shown).

15. Install freewheel cam (30) , freewheel springs (29) , freewheel rollers (28) , and bearing race (27) in stator (24) .

Note: Install freewheel springs (29) with the maximum number of loops toward the outside diameter of freewheel cam (30) .

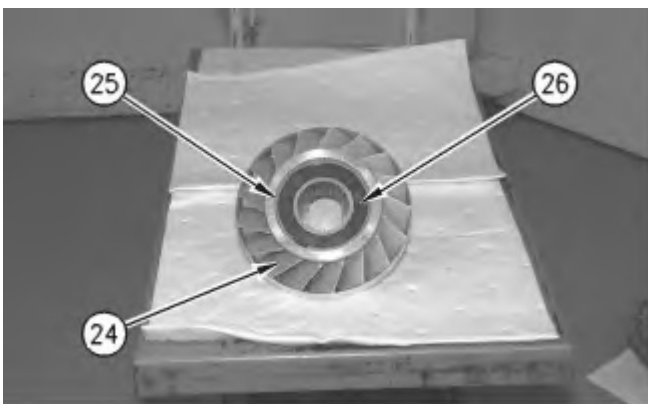

Illustration 13

g00877125

16. Install washer (26) and snap ring (25) on stator (24) . Repeat the procedure for the opposite side of stator (24) .

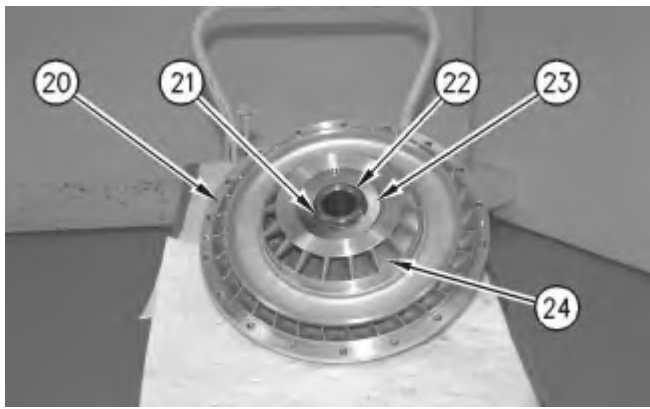

Illustration 14

g00877132

17. Install stator (24) on impeller (20) .
18. Install spacer (22) and snap ring (21) on carrier shaft (23) .



Illustration 15

g00319458

19. Install torque converter impeller (19) on the impeller housing.
20. Install bolts (18) . The torque for bolts (18) is 60 ± 7 N·m (44 ± 5 lb ft).

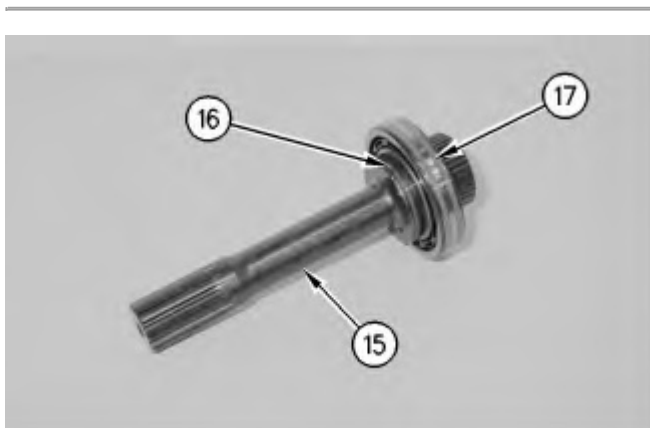

21. Install roller bearing (17) on output shaft (15) .
22. Install seal ring (16) .

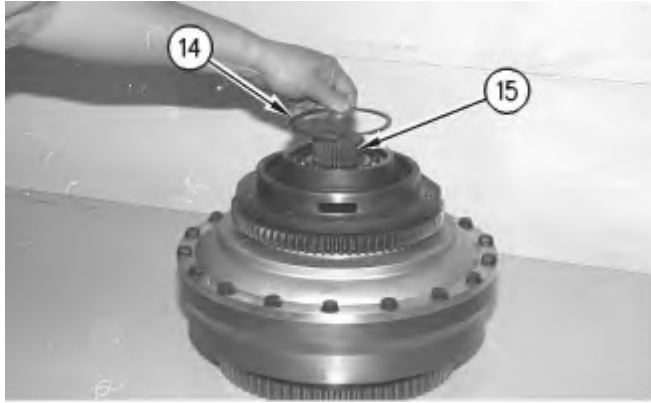

Illustration 17

23. Install output shaft (15) in the carrier assembly.
24. Install retaining ring (14) that secures output shaft (15) .

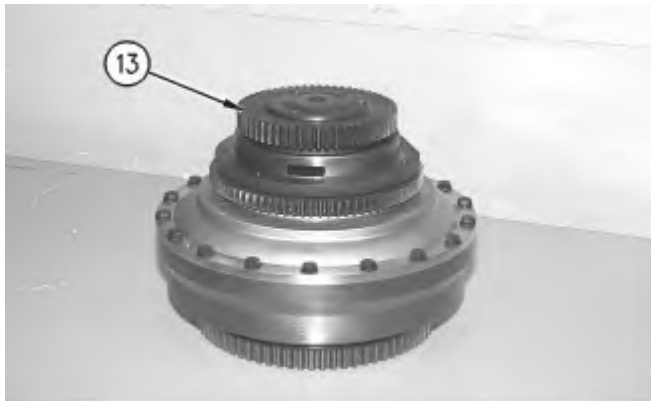

Illustration 18

25. Install drive gear (13) .
-



Illustration 19

g03652860

26. Install pump drive gear (11) to the underside of torque converter housing (1) .



Illustration 20

g03652939

27. Install Tooling (A) and a suitable lifting device to install torque converter housing (1) onto the torque converter assembly. The weight of torque converter housing (1) is approximately 113 kg (250 lb).



Illustration 21

g00319448

Thank you so much for reading.
Please click the “Buy Now!”
button below to download the
complete manual.



After you pay.

You can download the most
perfect and complete manual in
the world immediately.

Our support email:

ebooklibonline@outlook.com