

Product: TRACK LOADER

Model: 953K TRACK LOADER JNR

Configuration: 953K Track-Type Loader JNR00001-UP (MACHINE) POWERED BY C7.1 Engine

Disassembly and Assembly C7.1 Engines

Media Number -UENR0633-19

Publication Date -01/07/2015

Date Updated -29/10/2018

i05292322

Gear Group (Front) - Remove and Install - Heavy Duty Gear Group (Front)

SMCS - 1206-010

Removal Procedure

Table 1

Required Tools			
Tool	Part Number	Part Description	Qty
A ⁽¹⁾	9U-6198	Crankshaft Turning Tool	1
A ⁽²⁾	9U-7336	Housing	1
	5P-7305	Engine Turning Tool	1
B	230-6284	Timing Pin (Camshaft)	1
C	136-4632	Timing Pin (Crankshaft)	1
	268-1966	Adapter	1
D	298-5564	T40 Torx Socket	1

⁽¹⁾ The Crankshaft Turning Tool is used on the front pulley.

⁽²⁾ This Tool is used in the aperture for the electric starting motor.

Start By:

- a. Remove the front cover. Refer to Disassembly and Assembly, "Front Cover - Remove and Install" for the correct procedure.
 - b. Remove the valve mechanism cover. Refer to Disassembly and Assembly, "Valve Mechanism Cover - Remove and Install" for the correct procedure.
-

NOTICE

Keep all parts clean from contaminants.

Contaminants may cause rapid wear and shortened component life.

NOTICE

Care must be taken to ensure that fluids are contained during performance of inspection, maintenance, testing, adjusting and repair of the product. Be prepared to collect the fluid with suitable containers before opening any compartment or disassembling any component containing fluids.

Dispose of all fluids according to local regulations and mandates.

Note: Either Tooling (A) can be used. Use the Tooling that is most suitable. Care must be taken in order to ensure that the fuel injection pump timing is not lost during the removal of the front gear group. Carefully follow the procedure in order to remove the gear group.

1. If the air compressor is equipped with a hydraulic pump, remove the hydraulic pump. Refer to Original Equipment Manufactures (OEM) for the correct procedure.
 2. If the engine is equipped, with an air compressor remove the air compressor. Refer to Disassembly and Assembly, "Air Compressor - Remove" for the correct procedure.
 3. If the engine is equipped with only a hydraulic pump, remove the hydraulic pump. Refer to the OEM for the correct procedure.
-

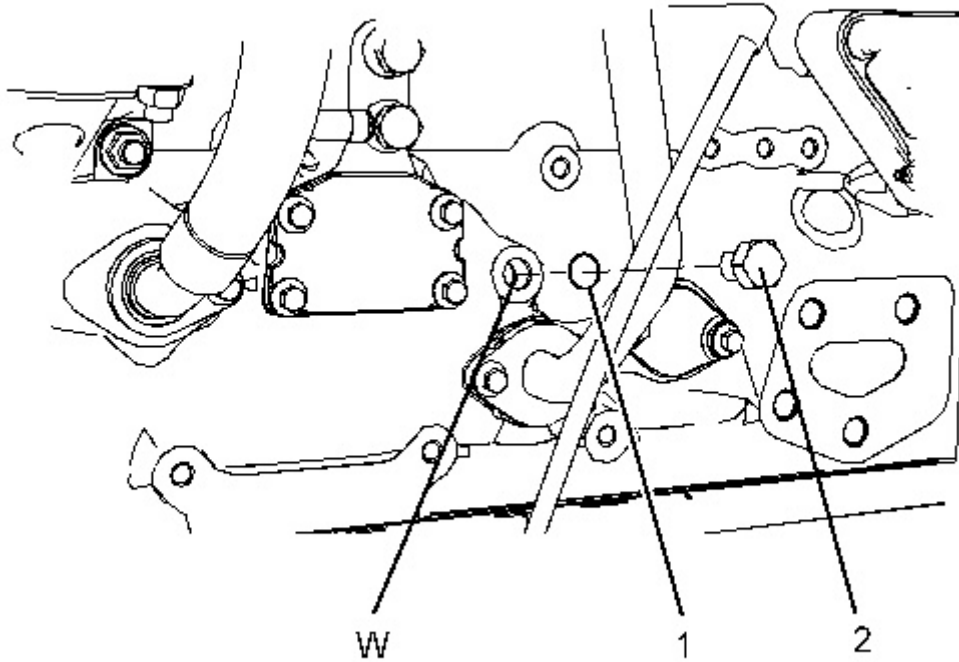

Illustration 1

g02048654

4. Remove plug (2) from the cylinder block. Remove O-ring seal (1) from the plug.
5. Use Tooling (A) in order to rotate the crankshaft so that number one piston is at top dead center on the compression stroke. Refer to System Operation, Testing and Adjusting, "Finding Top Center Position for No.1 Piston" for the correct procedure. Install Tooling (C) through Hole (W) in order to lock the crankshaft.

Note: Do not use excessive force to install Tooling (C). Do not use Tooling (C) to hold the crankshaft during repairs.

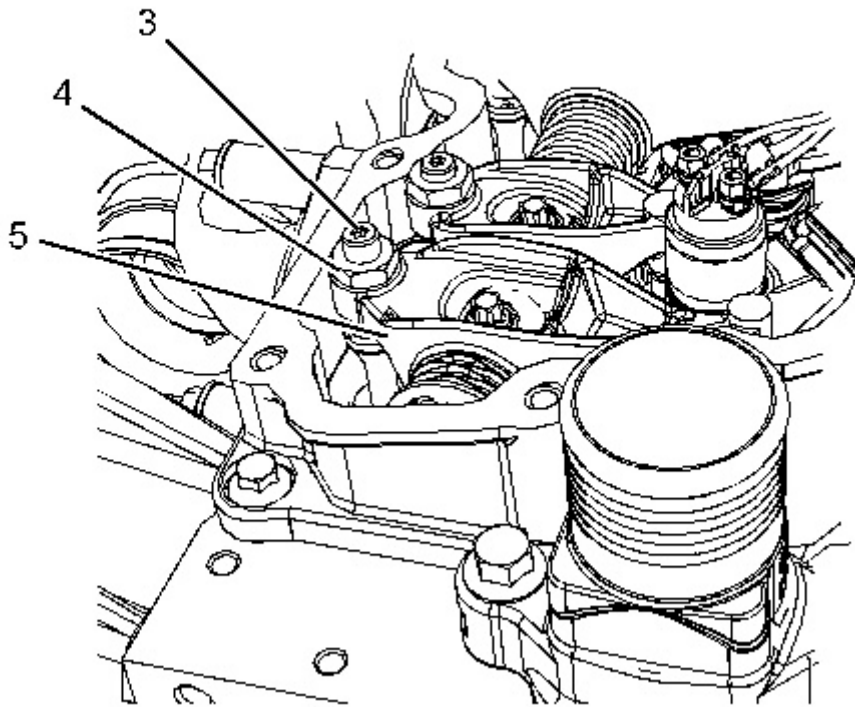

Illustration 2

g03388958

6. Loosen nuts (4) on all rocker arms (5). Use Tooling (D) in order to loosen adjusters (3) on all rocker arms (5) until all valves are fully closed.

Note: Failure to ensure that ALL adjusters are fully unscrewed can result in contact between the valves and pistons.

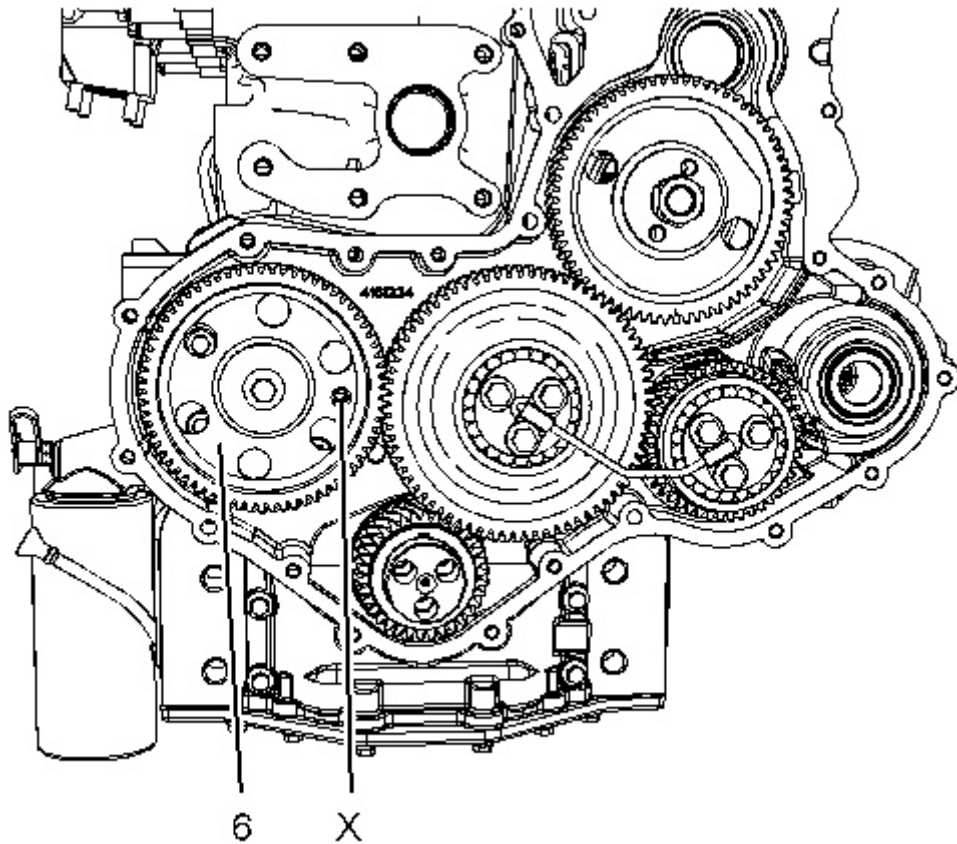

Illustration 3

g03389316

7. Install Tooling (B) through Hole (X) in camshaft gear (6) into the front housing. Use Tooling (B) in order to lock the camshaft in the correct position. Refer to System Operation, Testing and Adjusting, "Finding Top Center Position for No.1 Piston" for the correct procedure.
-

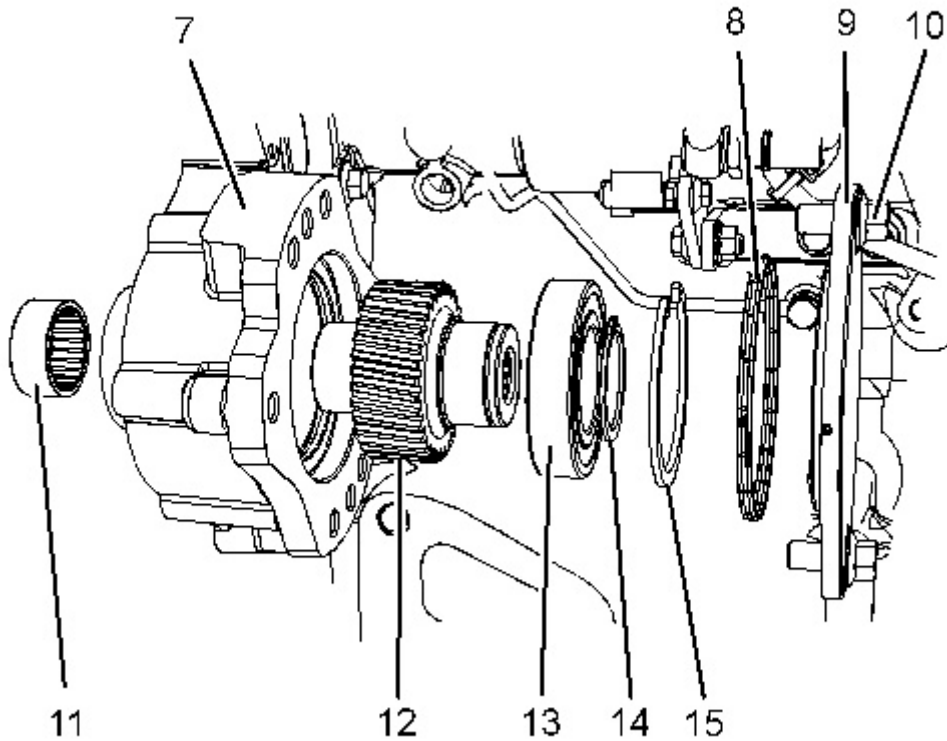

Illustration 4

g03389324

8. If the left-hand side of the engine is equipped, with a hydraulic pump remove the hydraulic pump. Refer to the OEM for the correct procedure to remove the hydraulic pump.
 9. If necessary, remove bolts (10) from plate (9). Remove plate (9) and remove O-ring seal (8).
 10. Remove circlip (15) and remove gear assembly (12) from front housing (7).
 11. If necessary, follow Step 11.a through Step 11.b in order to disassemble gear assembly (21).
 - a. Remove circlip (14) from gear (12).
 - b. Place gear assembly (12) on a suitable support. Press bearing (13) from gear (12).
 12. If necessary, remove bearing (11) from front housing (7). Refer to Disassembly and Assembly, "Housing (Front) - Remove" for the correct procedure.
-

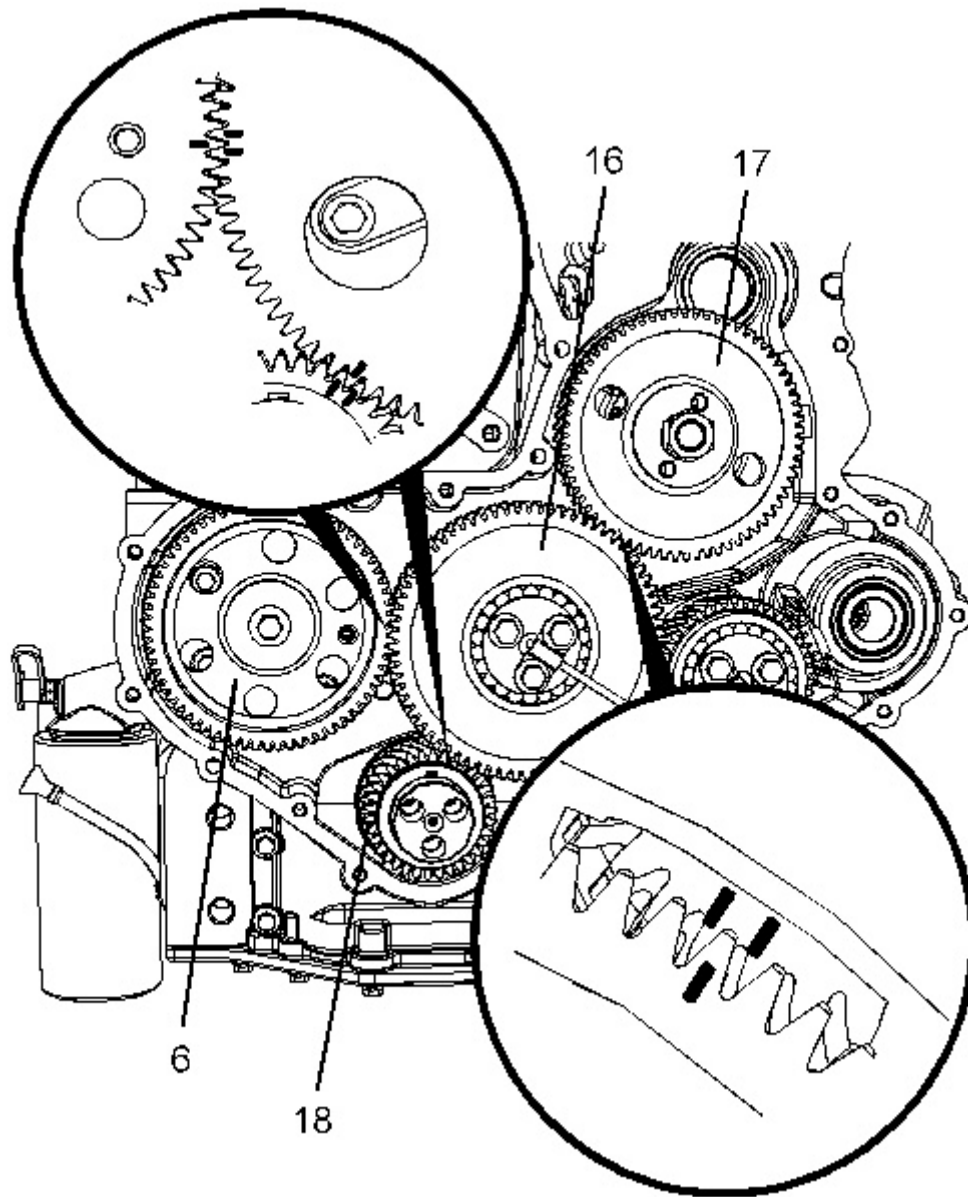

Illustration 5

g03388971

13. Mark gear (6), gear (16), gear (17), and gear (18) in order to show alignment. Refer to Illustration 5.

Note: Identification will ensure that the gears can be installed in the original alignment.

14. Remove camshaft gear (6). Refer to Disassembly and Assembly, "Camshaft Gear - Remove and Install" for the correct procedure.
15. Remove fuel injection pump gear (17). Refer to Disassembly and Assembly, "Fuel Injection Pump Gear - Remove" for the correct procedure.

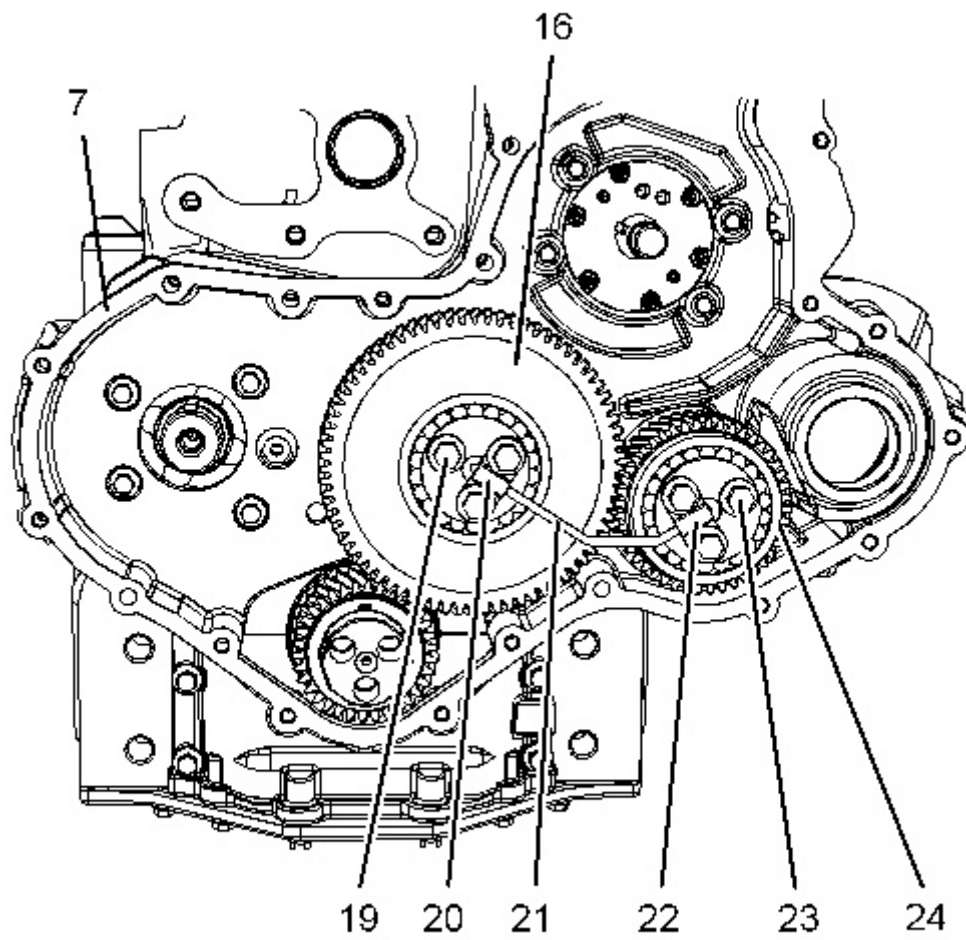

Illustration 6

g03388975

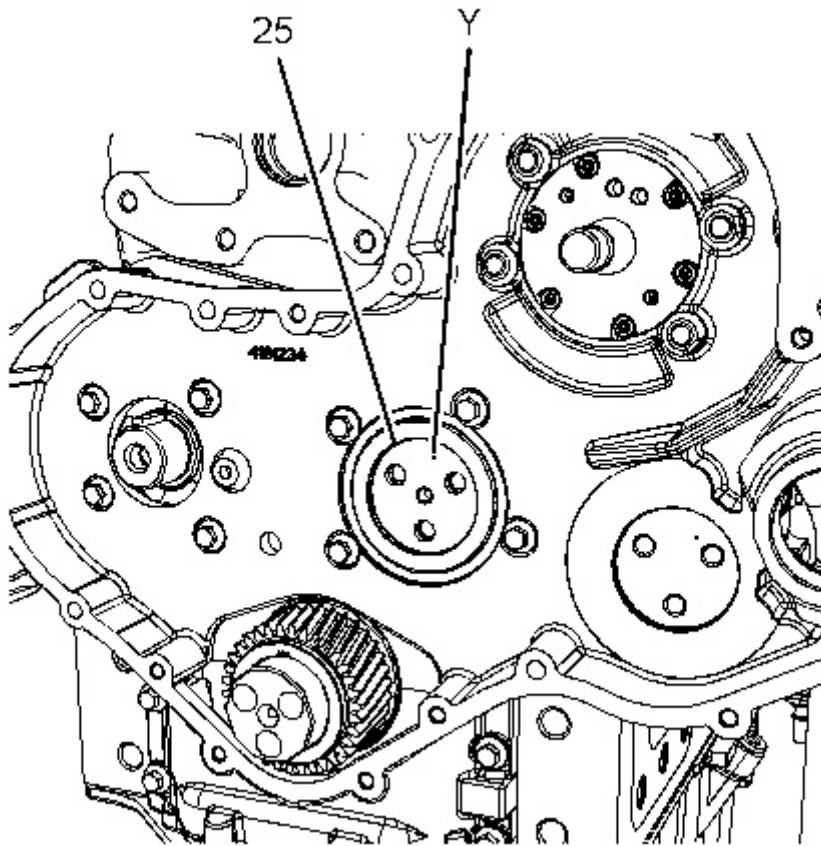

Illustration 7

g03389485

16. Remove bolts (19) and bolts (23).
17. Remove clip (20) and clip (22).
18. Remove tube assembly (21) from idler gear (16) and idler gear (24).
19. Remove idler gear (16) from front housing (7).
20. Remove idler gear (24) from front housing (7).
21. If necessary, remove plate (25). Note the position of oil Hole (Y).

Installation Procedure

Table 2

Required Tools			
Tool	Part Number	Part Description	Qty
A ⁽¹⁾	9U-6198	Crankshaft Turning Tool	1
A ⁽²⁾	9U-7336	Housing	1
	5P-7305	Engine Turning Tool	1

B	230-6284	Timing Pin (Camshaft)	1
C	136-4632	Timing Pin (Crankshaft)	1
	268-1966	Adapter	1
D	298-5564	T40 Torx Socket	1
E	7H-1942	Dial Indicator	1
	-	Magnetic Base and Stand	1
F	235-0032	Valve Lash Gauge Gp	1

⁽¹⁾ The Crankshaft Turning Tool is used on the front pulley.

⁽²⁾ This Tool is used in the aperture for the electric starting motor.

NOTICE

Keep all parts clean from contaminants.

Contaminants may cause rapid wear and shortened component life.

1. Ensure that number one piston is at top dead center on the compression stroke. Refer to System Operation, Testing and Adjusting, "Finding Top Center for No. 1 Piston" for the correct procedure.
-

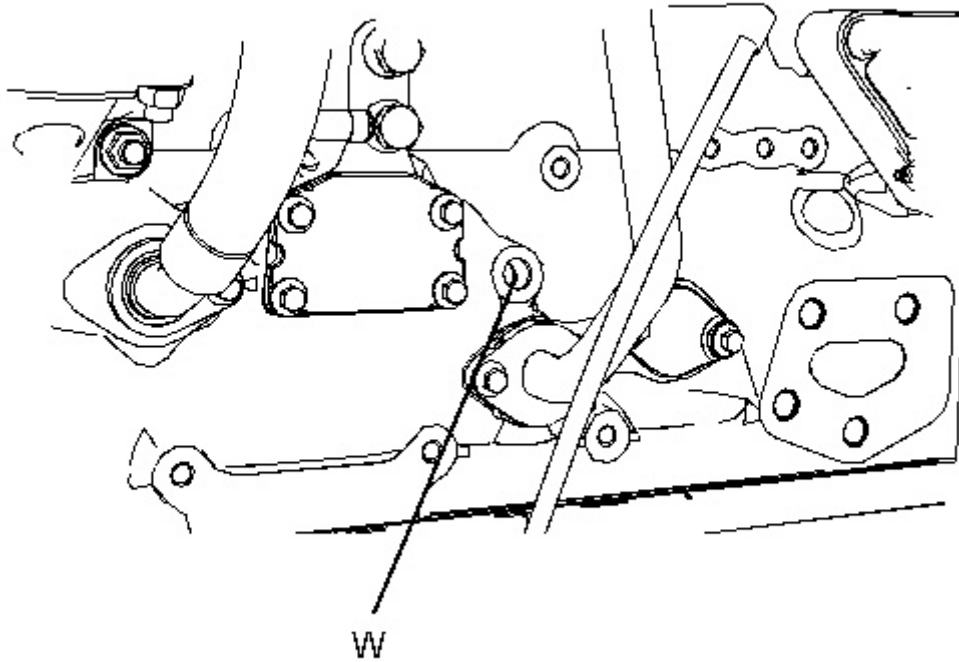

Illustration 8

g02048656

2. If necessary, install Tooling (C) into Hole (W) in the cylinder block. Use Tooling (C) in order to lock the crankshaft in the correct position. Refer to System Operation, Testing and Adjusting, "Finding Top Center Position for No.1 Piston".

Note: Do not use excessive force to install Tooling (C). Do not use Tooling (C) to hold the crankshaft during repairs.

3. Ensure that all of the components of the front gear group are clean and free from wear and damage. If necessary, replace any components that are worn or damaged.
-

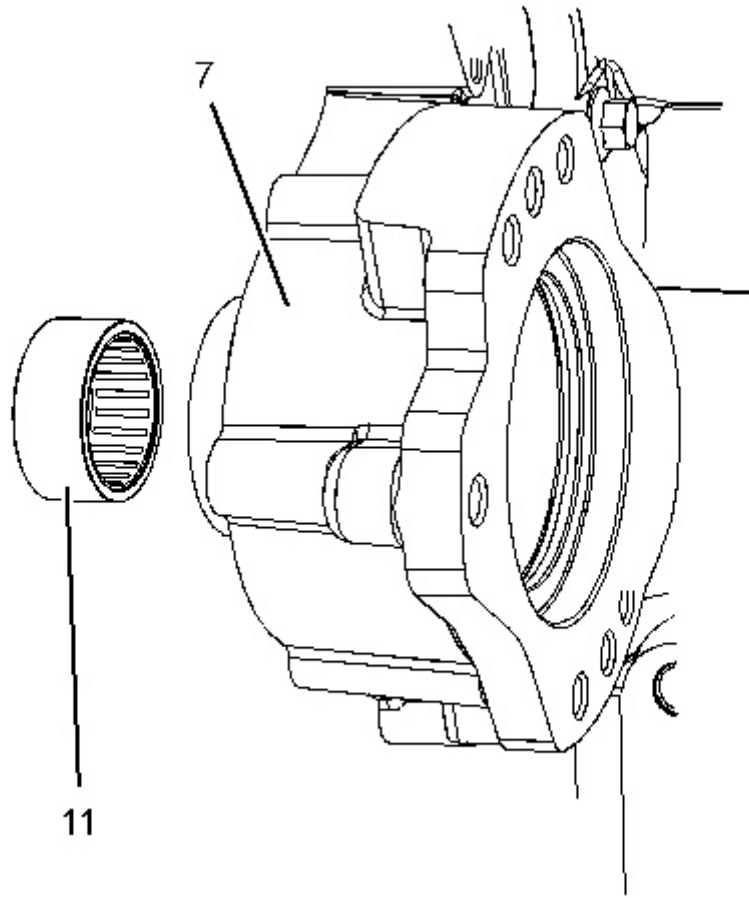

Illustration 9

g03389950

4. If necessary, install bearing (11) to front housing (7). Refer to Disassembly and Assembly, "Housing (Front) - Install" for the correct procedure.
-

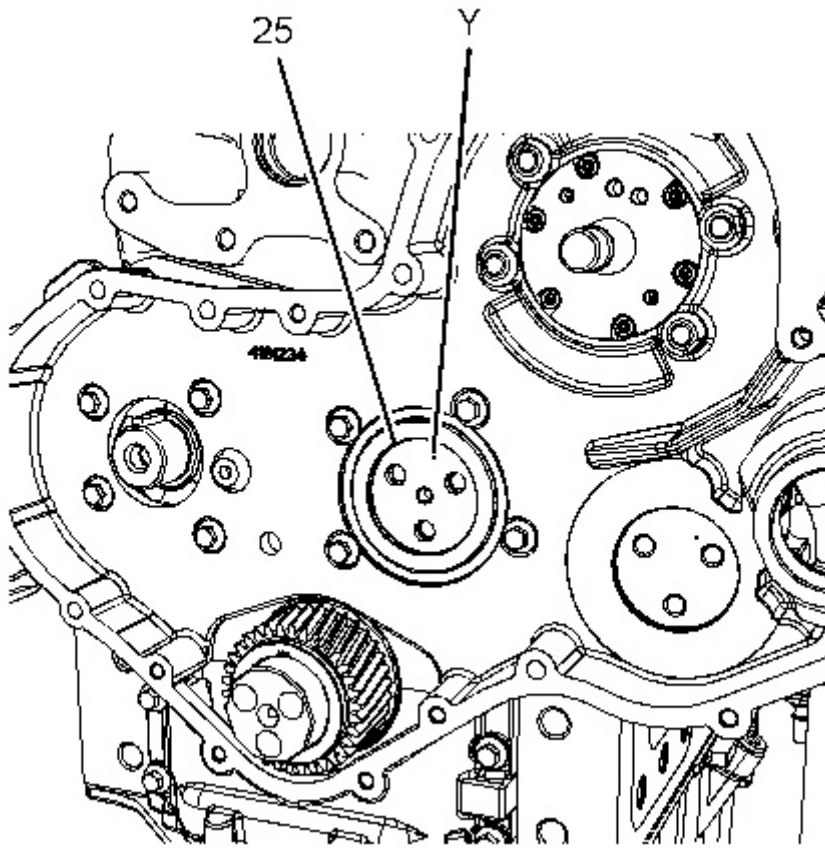

Illustration 10

g03389485

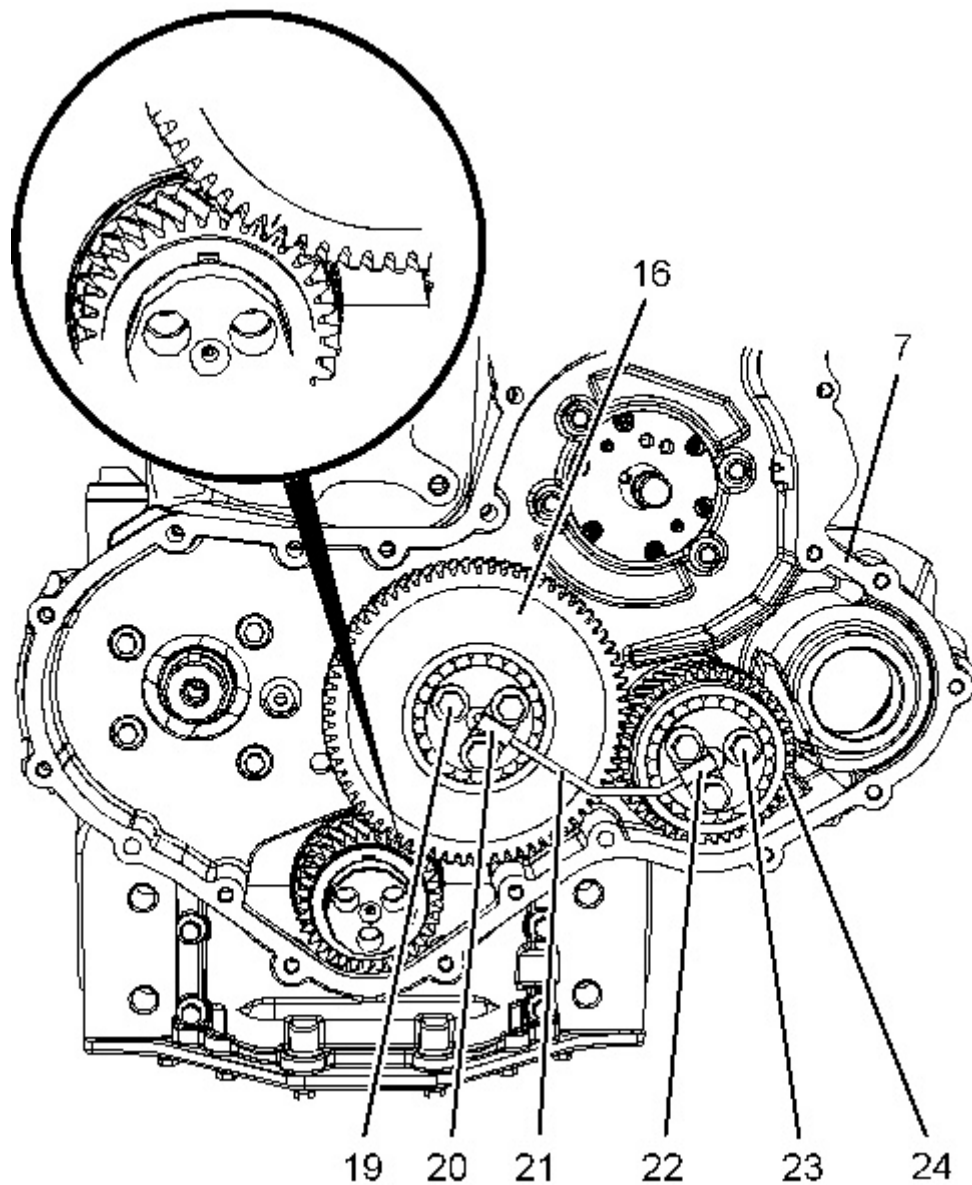

Illustration 11

g03389897

5. Install hub (25) to the recess of front housing (7). Ensure that oil Hole (Y) is to the top of the hub.
6. Lubricate idler gear (16) with clean engine lubricating oil. Install idler gear (16) to hub (25). Ensure that the timing marks are toward the front of the idler gear.
7. Align timing marks on idler gear (16) with the crankshaft gear.
8. Lubricate idler gear (24) with clean engine lubricating oil. Install idler gear (24) to housing (7). Ensure that idler gear (24) is correctly aligned with idler gear (16).
9. Position tube assembly (21) onto idler gear (16) and idler gear (24).
10. Position clip (20) onto tube assembly (21). Install bolts (19) hand tight.
11. Position clip (22) onto tube assembly (21). Install bolts (23) hand tight.

12. Tighten bolts (19) and bolts (23) to a torque of 44 N·m (32 lb ft).

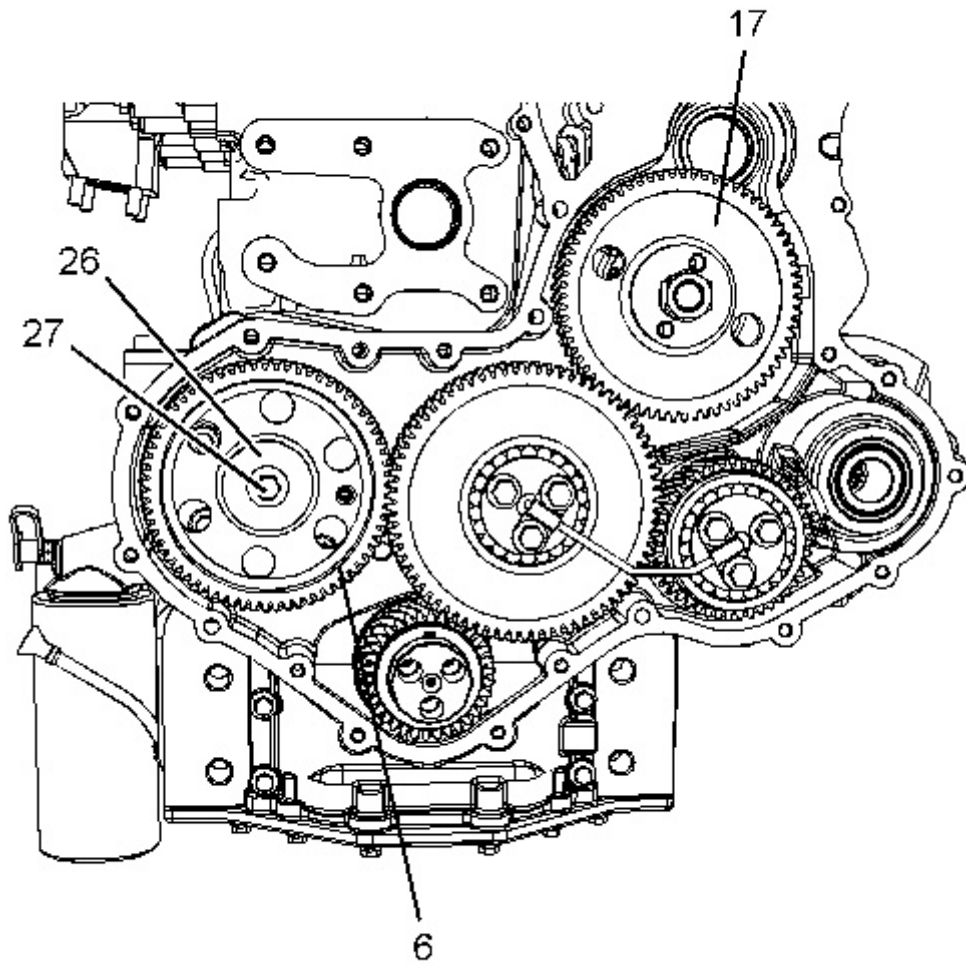

Illustration 12

g03389918

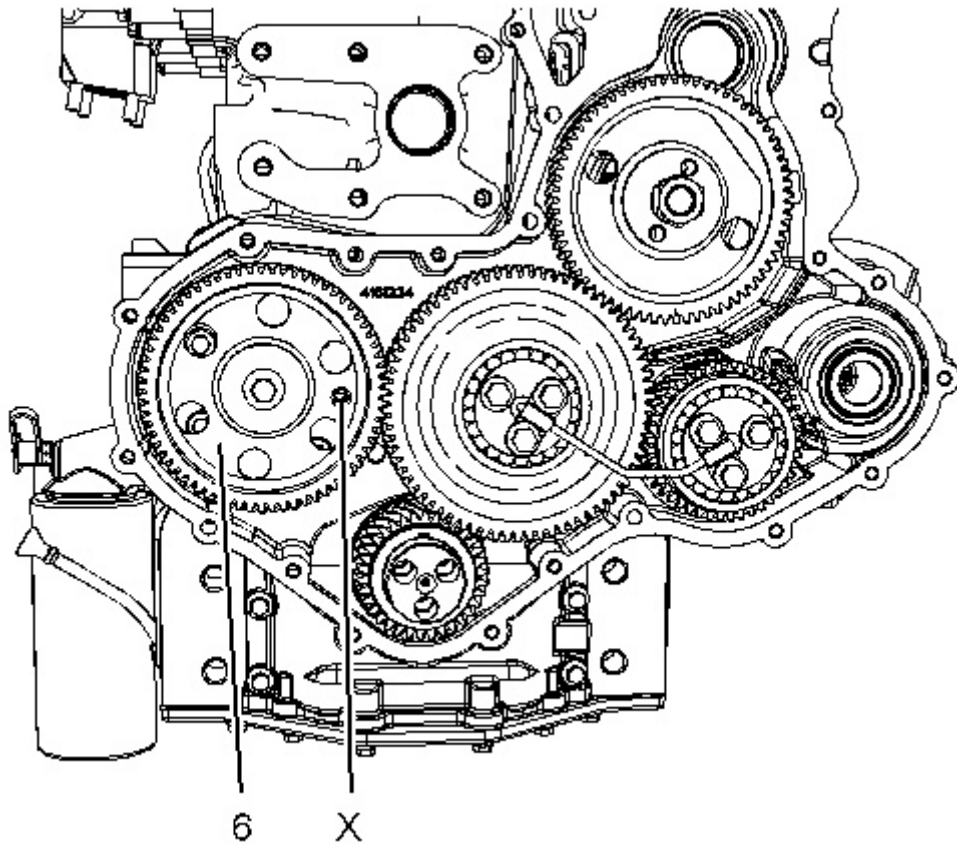

Illustration 13

g03389919

13. Install camshaft gear (6). Loosely install bolt (27) and washer (26) for the camshaft gear. Refer to Disassembly and Assembly, "Camshaft Gear - Remove and Install" for the correct procedure.
 14. Install Tooling (B) through Hole (X) in camshaft gear (6) into the front housing.
 15. Install fuel injection pump gear (17). Refer to Disassembly and Assembly, "Fuel Injection Pump Gear - Remove and Install" for the correct procedure.
-

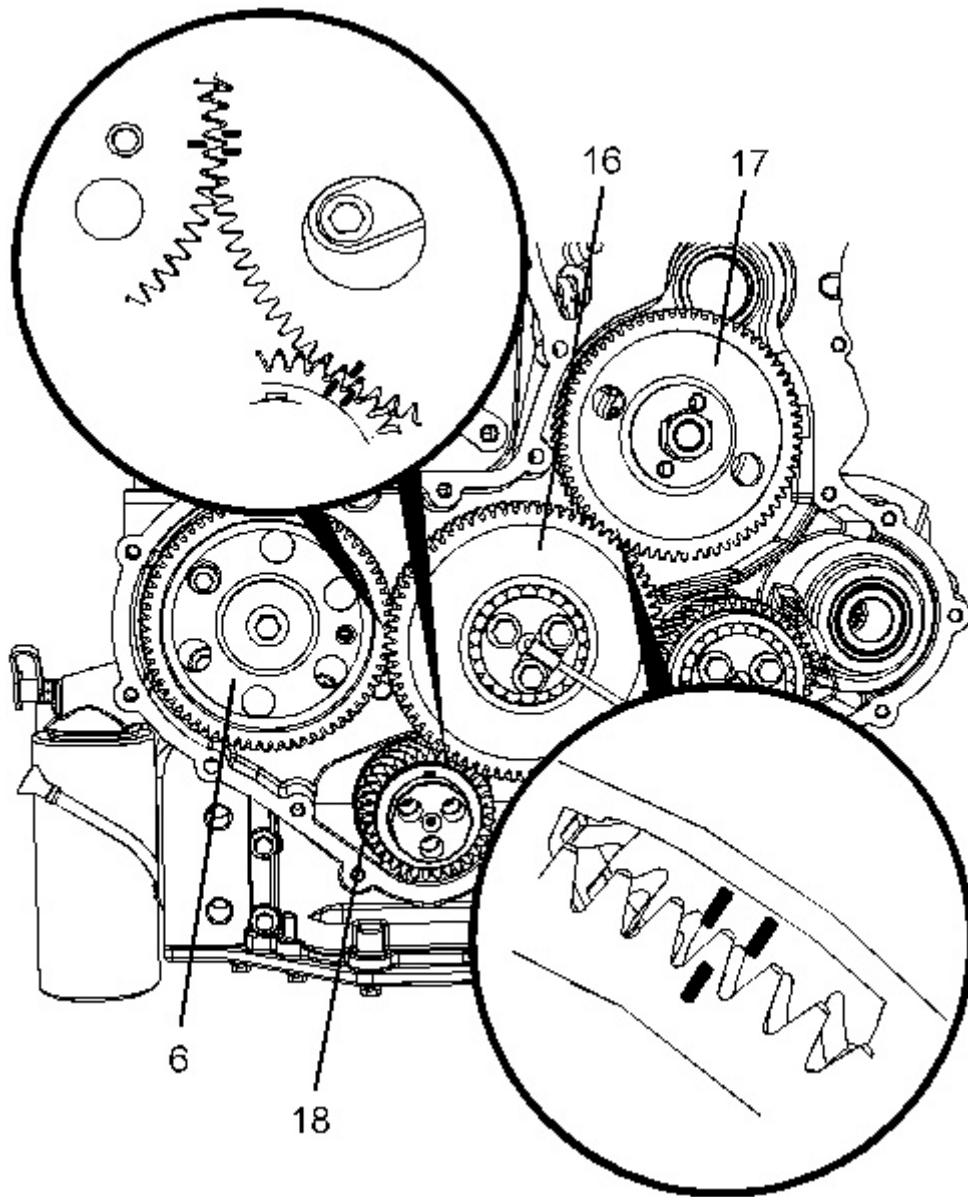

Illustration 14

g03388971

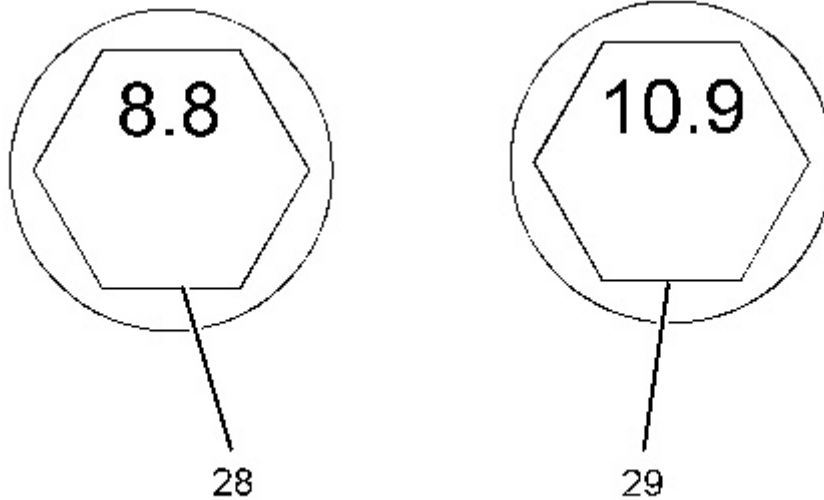

Illustration 15

g03389922

16. Ensure that the timing marks on gear (6), gear (16), gear (17), and gear (18) are in alignment.
 17. Remove Tooling (B) and Tooling (C).
 18. When a 8.8 Graded bolt (28) is installed. Tighten the bolt to a torque of 95 N·m (70 lb ft).
When a 10.9 Graded bolt (29) is installed. Tighten the bolt to a torque of 120 N·m (89 lb ft).
 19. Tighten the nut for fuel injection pump gear (17). Refer to Disassembly and Assembly, "Fuel Injection Pump Gear - Remove and Install" for the correct procedure.
 20. Use Tooling (E) in order to check the end play of the camshaft gear. Refer to Specifications, "Camshaft" for more information.
 21. Use Tooling (E) in order to check the end play of the idler gears. Refer to Specifications, "Gear Group (Front)" and refer to Disassembly and Assembly, "Idler Gear - Remove and Install" for more information.
 22. Use Tooling (E) in order to measure the backlash for gear (6), gear (26), and gear (25). Refer to Specifications, "Gear Group (Front)" for more information.
-

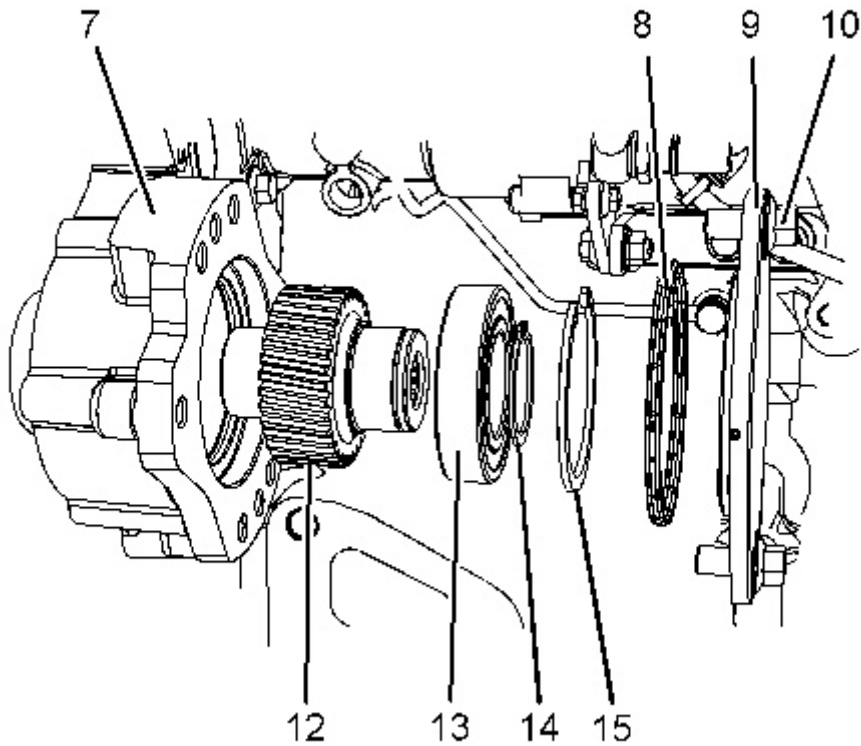

Illustration 16

g03389988

23. If necessary, follow Step 23.a through Step 23.d in order to assemble the gear assembly (12).
 - a. Place gear (12) on a suitable support.
 - b. Position bearing (13) onto gear (12) with open face of the bearing toward the gear.
 - c. Press on the inner race of bearing (13). Press the bearing onto gear (12) until the shoulder of the bearing is against the gear.
 - d. Install circlip (14) to gear (12).
24. Install gear assembly (12) to front housing (7).
25. Install circlip (15) to front housing (7). Ensure that the circlip is correctly installed to the recess in the front housing.
26. Ensure that gear assembly (12) has tactile backlash.
27. If the left-hand side of the engine is equipped, with a hydraulic pump install the hydraulic pump. Refer to the OEM for the correct procedure to install the hydraulic pump.
28. If necessary, install a new O-ring seal (8) to plate (9).
29. Position plate (9) onto front housing (7) and install bolts (10). Tighten the bolts to a torque of 44 N·m (32 lb ft).

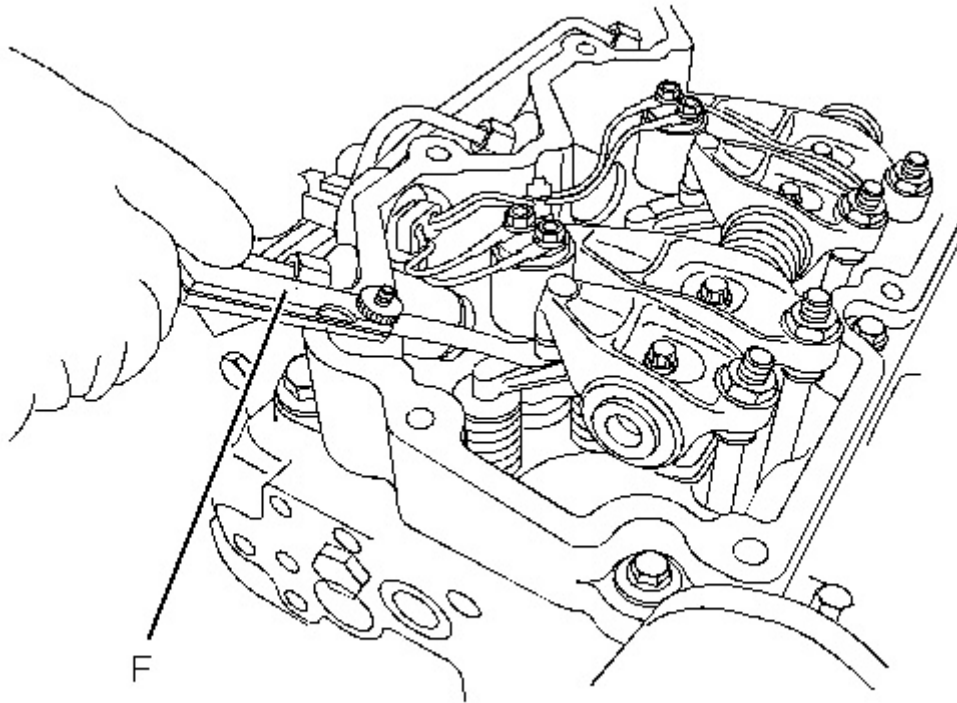

Illustration 17

g03389432

30. Use Tooling (F) in order to check the valve lash. Refer to System Operation, Testing and Adjusting, "Engine Valve Lash - Inspect/Adjust". If necessary, use Tooling (G) and Tooling (D) to adjust the valve lash. Refer to System Operation, Testing and Adjusting, "Engine Valve Lash - Inspect/Adjust" for the correct procedure.
-

Buy Now



Our support email:

ebooklibonline@outlook.com