

Product: TRACK LOADER
Model: 955L TRACK LOADER 64J
Configuration: 955K TRAXCAVATOR 64J00001-03993 (MACHINE)

Disassembly and Assembly 955K TRACK-TYPE LOADER POWER TRAIN

Media Number -REG00861-00

Publication Date -01/11/1993

Date Updated -10/10/2001

Transmission Lubrication System Components

SMCS - 1405-016

Transmission Lubrication Relief Valve Removal And Installation

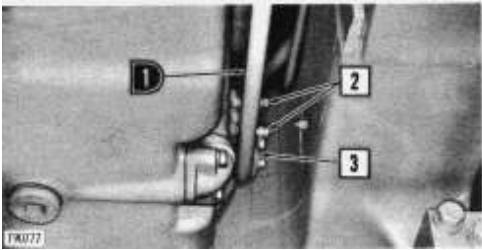

1-Tube assembly. 2-Bolts (four). 3-Lubrication relief valve.

Lubrication Relief Valve Disassembly

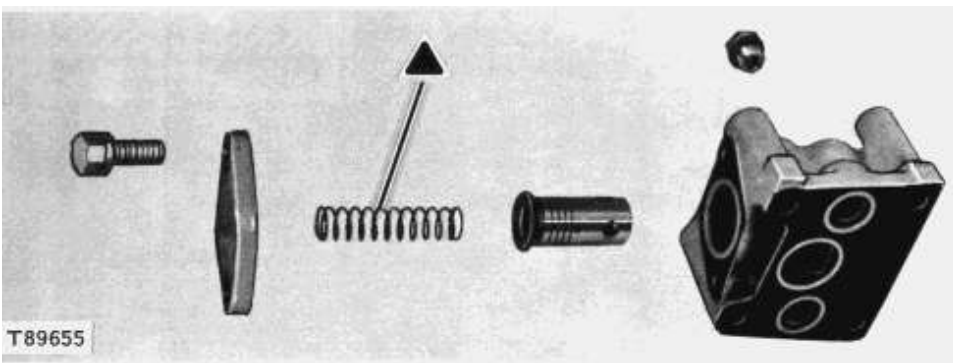

Oil Pump Removal And Installation

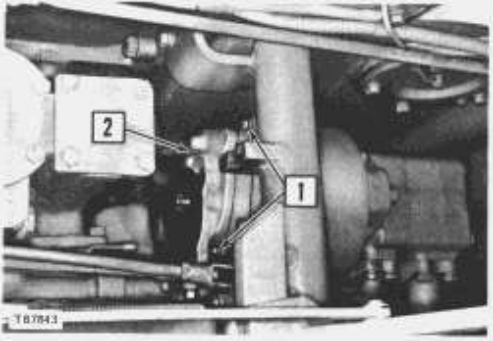

1-Bolts (two). 2-Transmission oil pump.

Oil Pump Disassembly

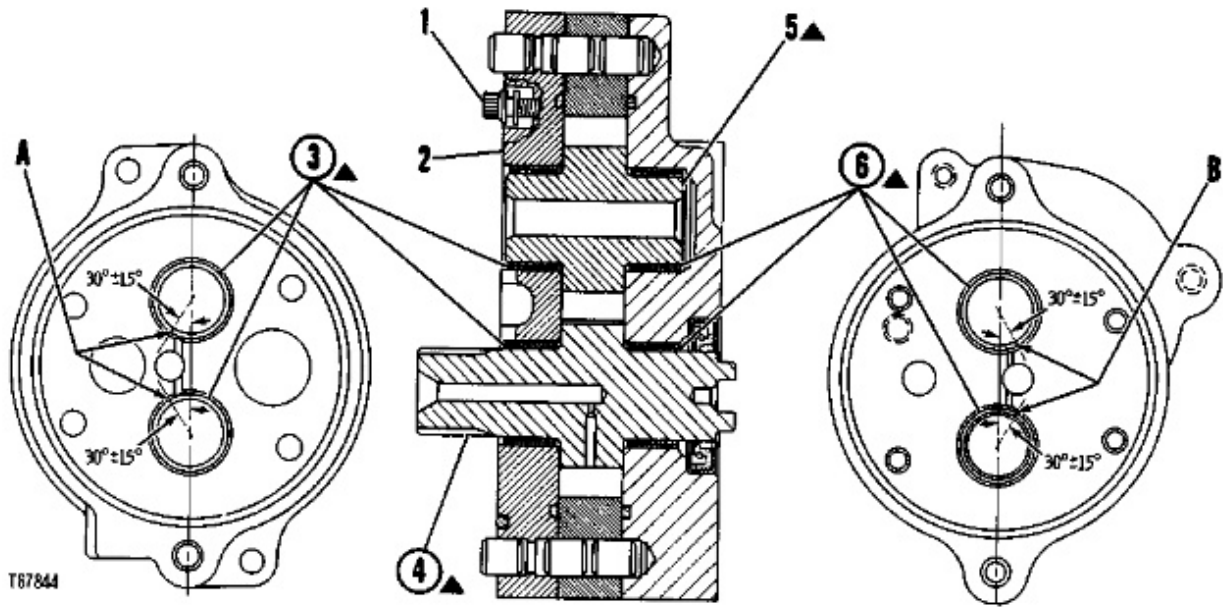

3, 6 Install bearings with joints at (A and B) as shown. Install bearings .062 in. (1,575 mm) below the inner surfaces of the cover and base.

4 Pump drive gear must rotate freely by hand.

Transmission Oil Filter And Screen Removal And Installation

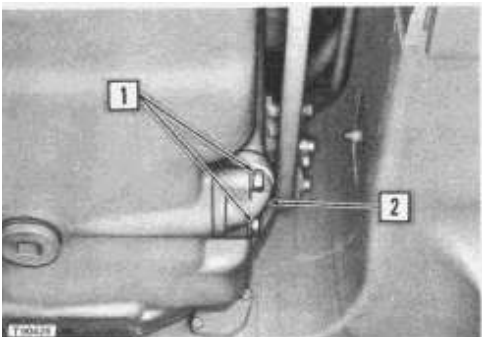

1-Bolts (two). 2-Oil pump supply tube and O-ring seal.

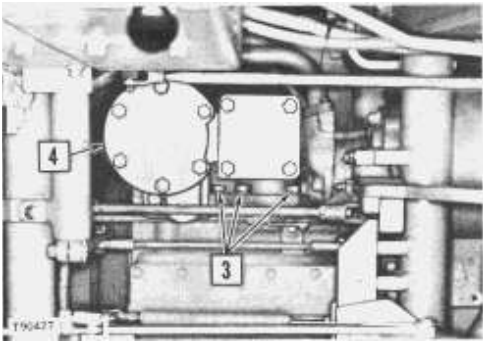

3-Nuts (five). 4-Filter and screen group with O-ring seals.

Transmission Oil Filter And Screen Disassembly

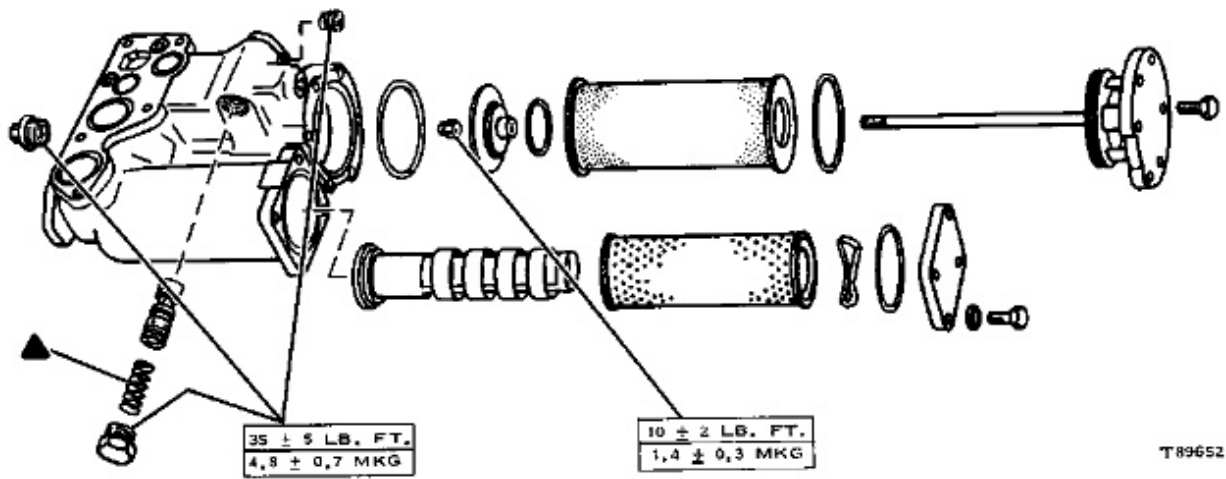

T89652

Product: TRACK LOADER
Model: 955L TRACK LOADER 64J
Configuration: 955K TRAXCAVATOR 64J00001-03993 (MACHINE)

Disassembly and Assembly 955K TRACK-TYPE LOADER POWER TRAIN

Media Number -REG00861-00

Publication Date -01/11/1993

Date Updated -10/10/2001

Bevel Pinion

SMCS - 1405-016

Transmission Mounting Adapter Removal And Installation

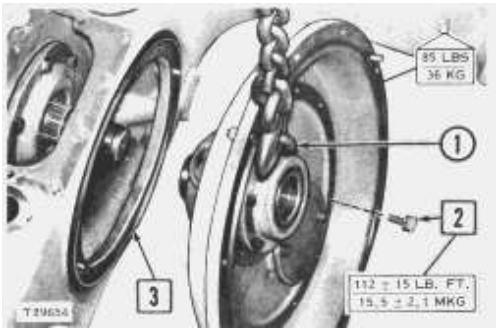

1-Forged eyebolt (1/2"-13 NC) and nut. Install eyebolt and nut and attach a hoist. 2-Bolts (eleven). 3-Seal.

Transmission Mounting Adapter Disassembly

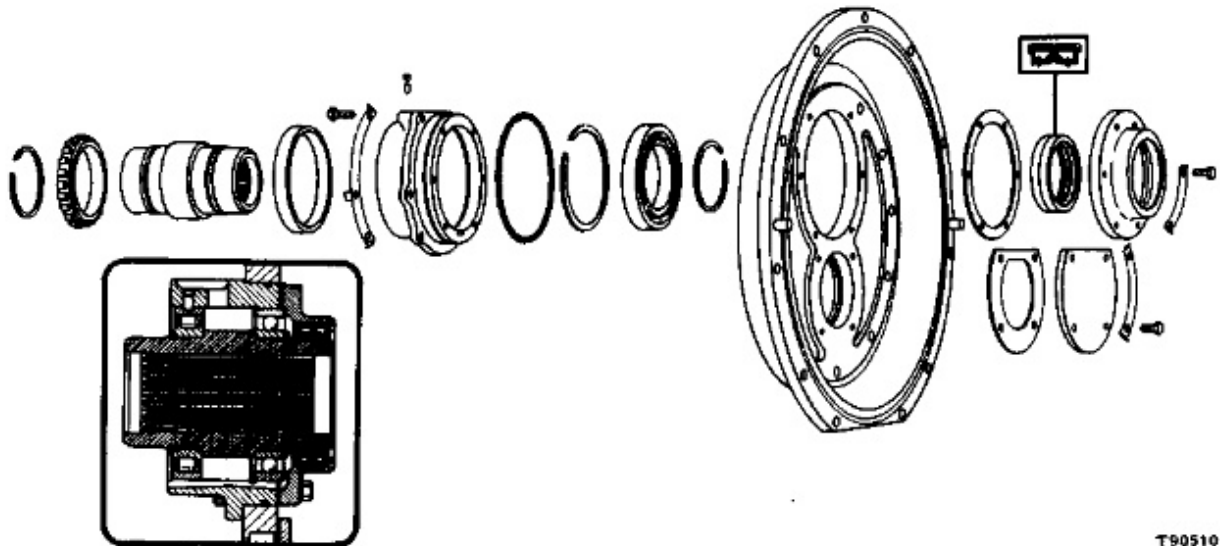

T90510

Bevel Pinion, Bearing Cage And Pinion Locating Shims Removal And Installation

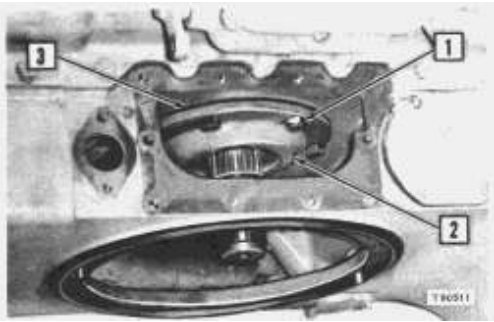

1-Bolts (four). 2-Bevel pinion bearing cage and bevel pinion. 3-Bevel pinion locating shims.

NOTE: If the bevel gear location is changed or if a new bearing cage or pinion is installed, the pinion location must be checked. See BEVEL GEAR AND PINION SETTING.

Bevel Pinion And Bearing Disassembly

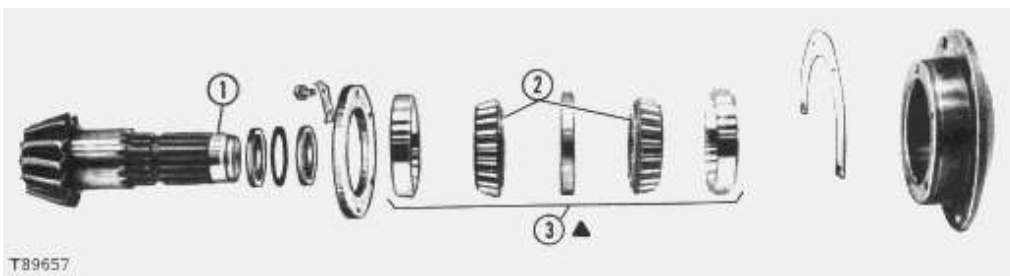

1 Press spacer onto bevel pinion shaft before installing shaft.

2 Use an arbor press to remove bearing cones.

3 For correct installation see the GENERAL INSTRUCTIONS under BEARINGS - DOUBLE ROW, TAPERED ROLLER.

Product: TRACK LOADER
Model: 955L TRACK LOADER 64J
Configuration: 955K TRAXCAVATOR 64J00001-03993 (MACHINE)

Disassembly and Assembly 955K TRACK-TYPE LOADER POWER TRAIN

Media Number -REG00861-00

Publication Date -01/11/1993

Date Updated -10/10/2001

Steering Clutch And Brake Controls

SMCS - 1405-016

Control Pedals Removal



1-Brake lock linkage. 2-Bracket. Remove two bolts securing bracket to support.

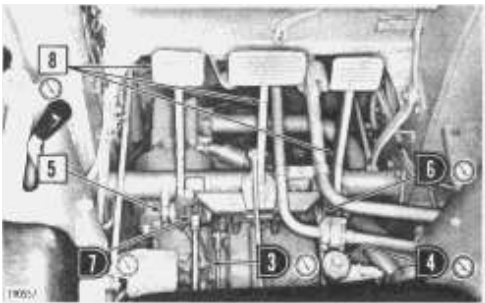

3-Left steering clutch control linkage. 4-Right steering clutch control linkage. 5-Caps (six). 6-Right brake control linkage. 7-Left brake control linkage. 8-Control pedal assemblies.

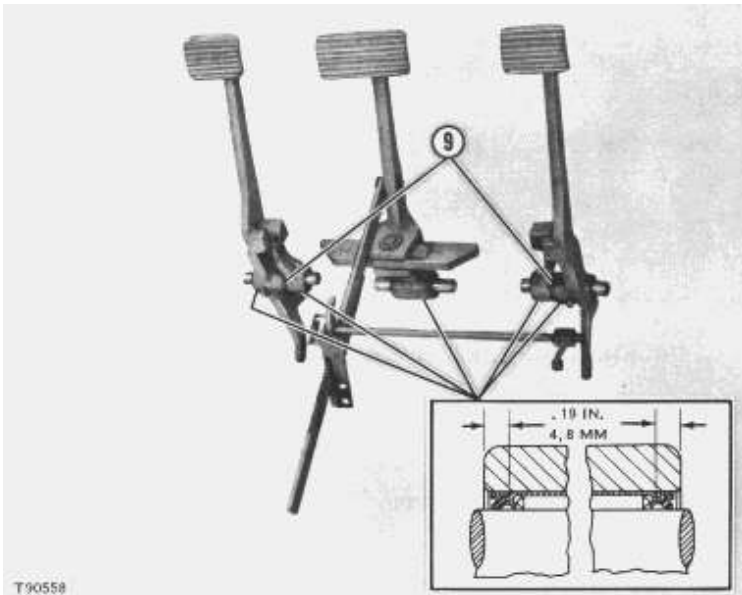

This shows the pedals removed from the machine. The parts pointed out are: 9-Shims. Use as necessary to provide clearance between levers and pedals.

Control Pedals And Support Brace Unit Removal And Installation

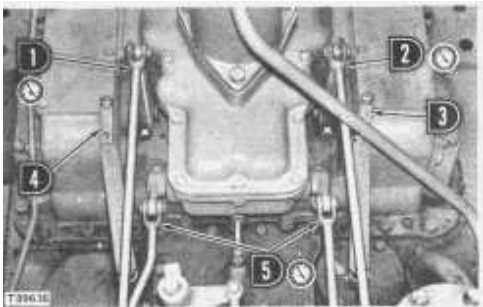

1-Right brake control rod. 2-Left brake control rod. 3-Left brake pedal return spring. 4-Right brake pedal return spring. 5-Steering clutch control rods.

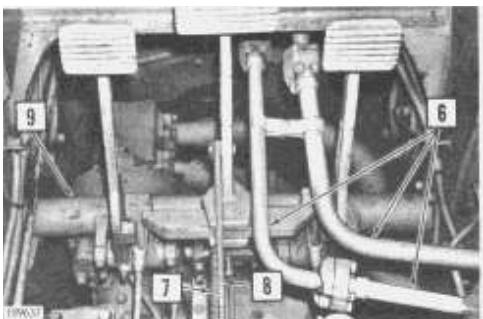

6-Tilt cylinder lines. 7-Center brake pedal return spring. 8-Parking brake lock ratchet. 9-Control pedals and support brace unit.

Steering Clutch Oil Filter Removal And Installation

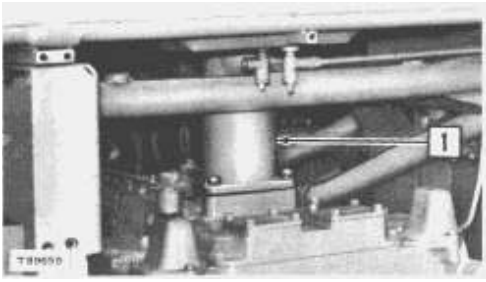

1-Steering clutch oil filter.

Steering Clutch Oil Filter Disassembly

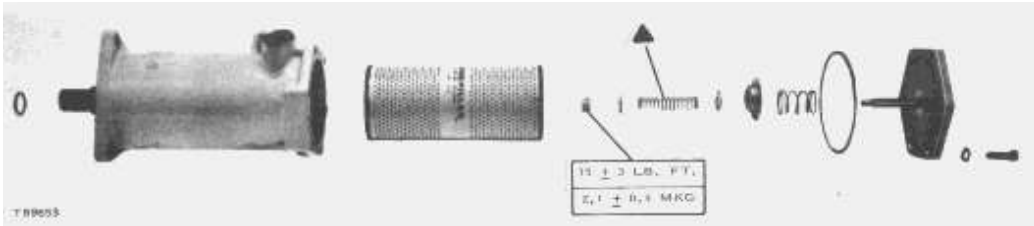

Steering Clutch Oil Screen

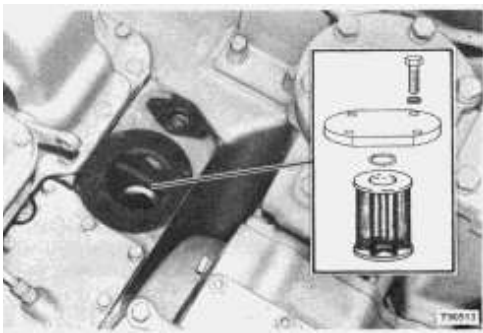

Steering Clutch Hydraulic Booster Removal

1. Remove steering booster cover.

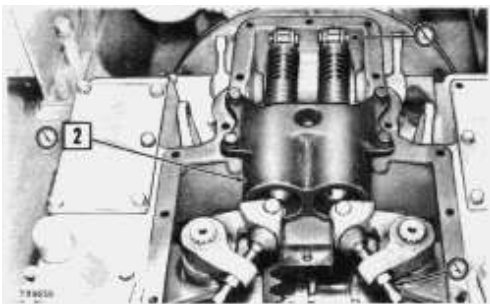

2-Steering clutch hydraulic booster.

Steering Clutch Hydraulic Booster Disassembly

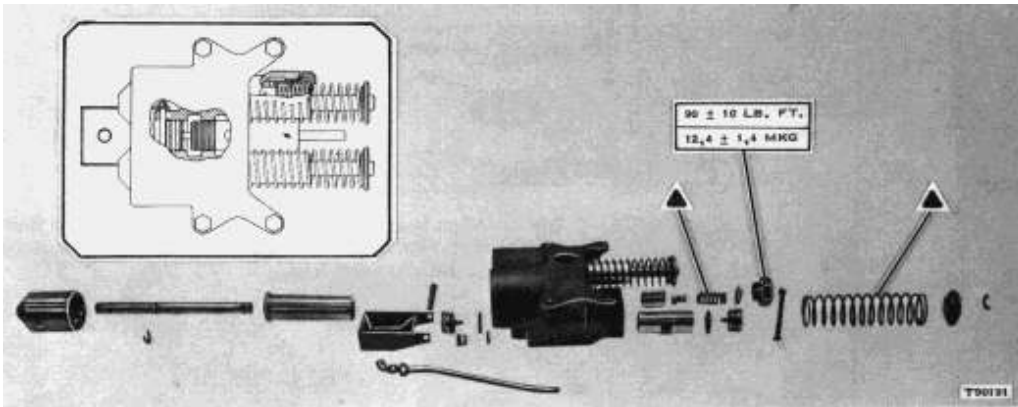

Oil Pump Removal And Installation

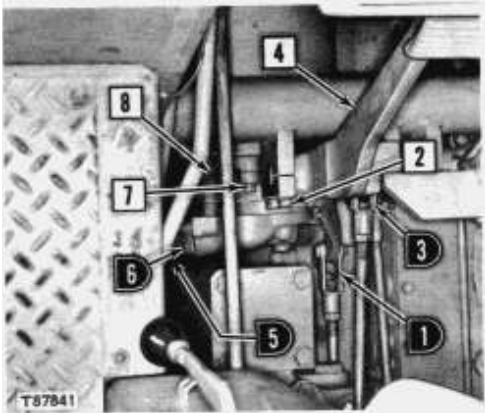

Viewed from rear. 1-Left steering clutch control rod. 2-Bolts (four). 3-Left steering clutch brake control rod. 4-Left steering clutch pedal. 5-Pump outlet oil line. 6-Pump inlet oil line. 7-Bolts (two). 8-Steering clutch oil pump.

Oil Pump Disassembly

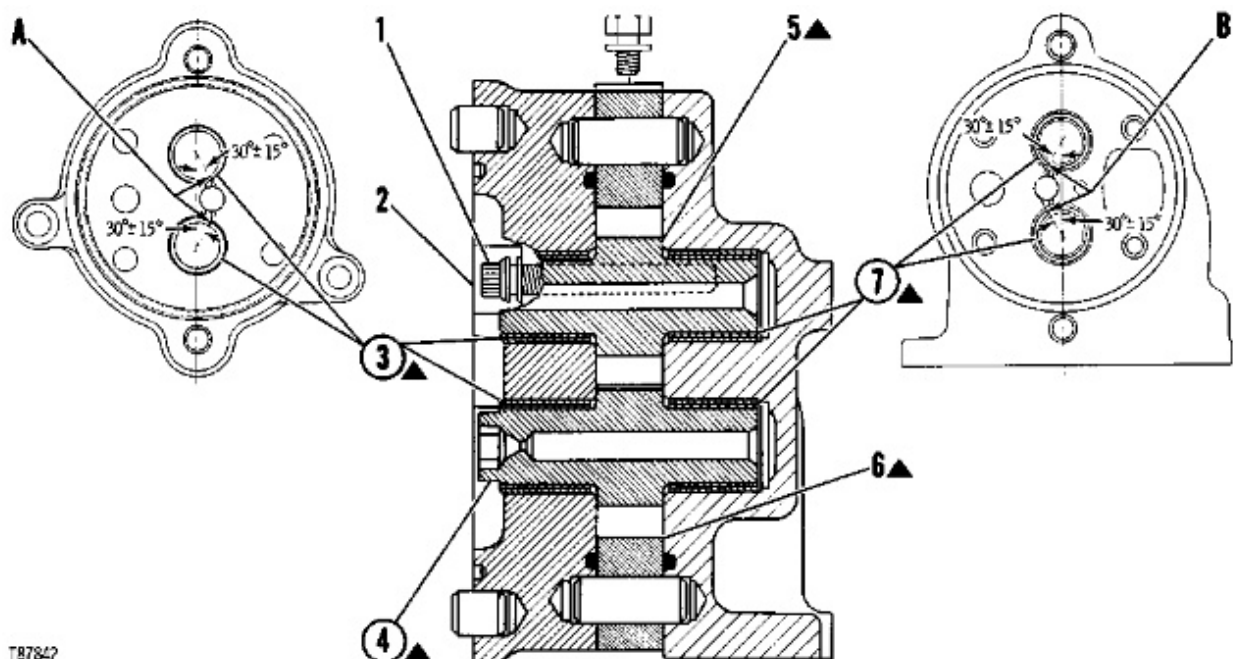

3,7 Align bearing joints (at A and B) and install bearings .062 in. (1,57 mm) below the inner surfaces of the cover and base.

4 Pump drive gear must rotate freely by hand.

Steering Clutch Mechanical Components

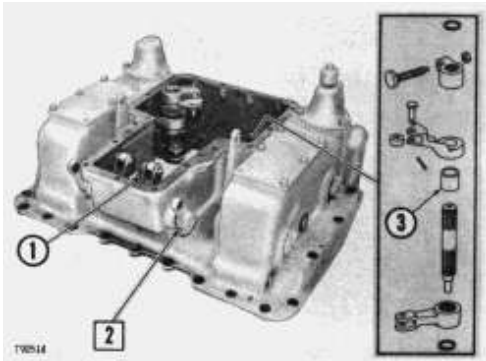

1-Lever. Loosen bolt and remove key holding lever to shaft. 2-Lever and shaft. 3-Race. At assembly press onto shaft so top of race is 2.78 in. (70,6 mm) from upper end of shaft.

Steering Clutch Case Cover

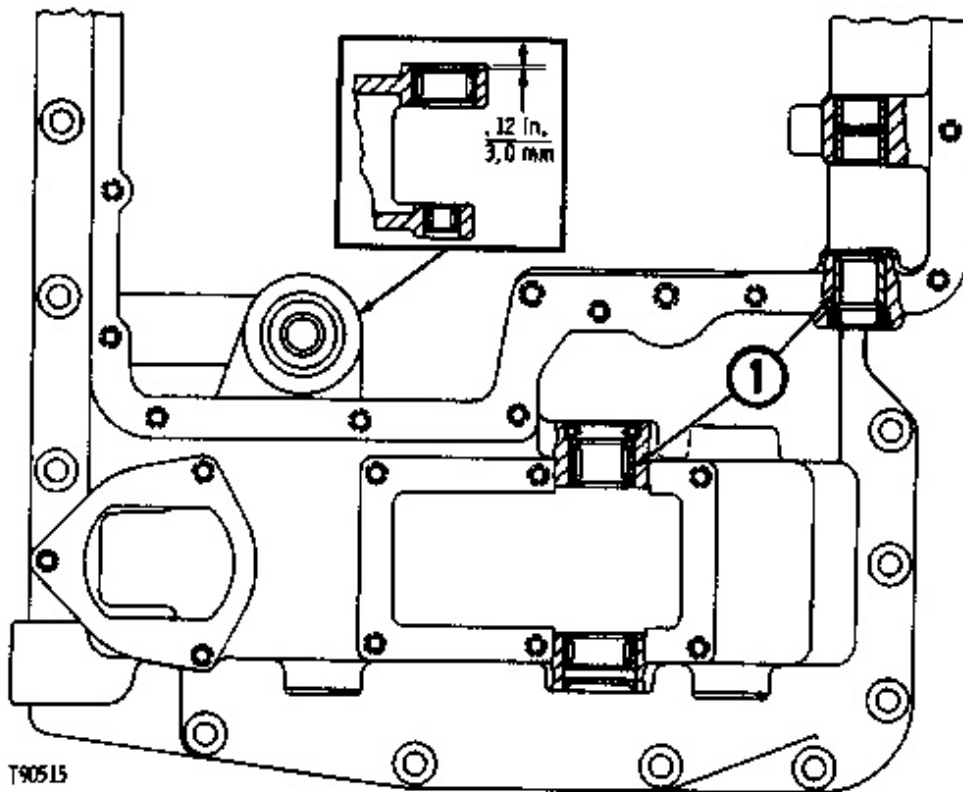

1-Bearings. Not to project above bottom of counterbore.

Brake Engaging Mechanism

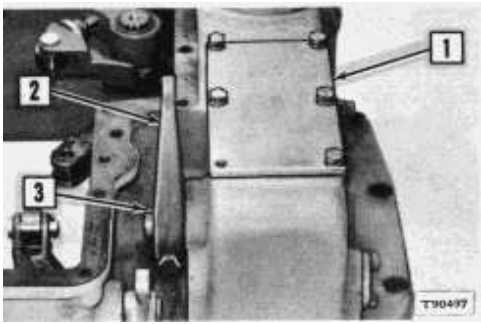

1-Cover. 2-Lever. 3-Key.

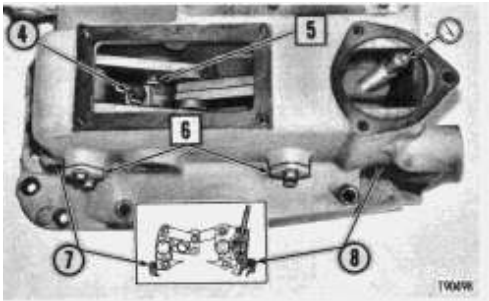

4-Bolt. Loosen and slide shaft through lever far enough to allow key to be removed from shaft. 5-Shaft. 6-Shaft assemblies. 7-Stop shaft. 8-Stop shaft.

If stop shafts are removed from steering clutch case cover, the setscrews which hold the shafts in position must be adjusted when installing the shafts. To do this, tighten the setscrews, then back off 1 1/2 turns and lock with lock wire.

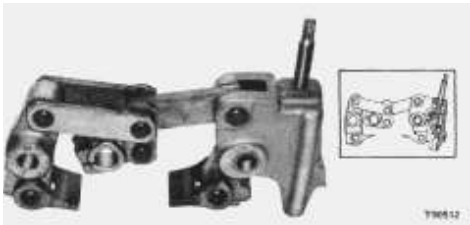

Product: TRACK LOADER
Model: 955L TRACK LOADER 64J
Configuration: 955K TRAXCAVATOR 64J00001-03993 (MACHINE)

Disassembly and Assembly 955K TRACK-TYPE LOADER POWER TRAIN

Media Number -REG00861-00

Publication Date -01/11/1993

Date Updated -10/10/2001

Steering Clutches, Bevel Gear And Final Drive

SMCS - 1405-016

Steering Clutch Case Cover Removal

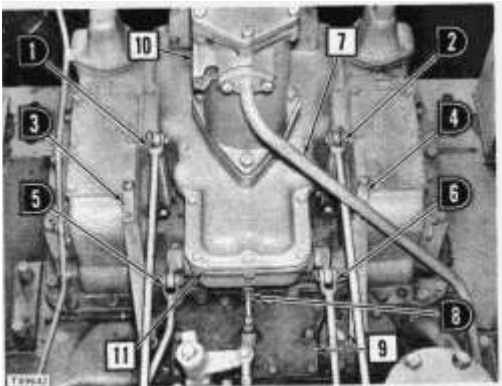

Viewed from front of machine 1-Right brake control rod. 2-Left brake control rod. 3-Right pedal return spring. 4-Left pedal return spring. 5-Right steering clutch control rod. 6-Left steering clutch control rod. 7-Steering clutch case oil supply line. 8-Tube. 9-Cover. 10-Oil filter. 11-Steering booster cover.

12. Remove steering booster.

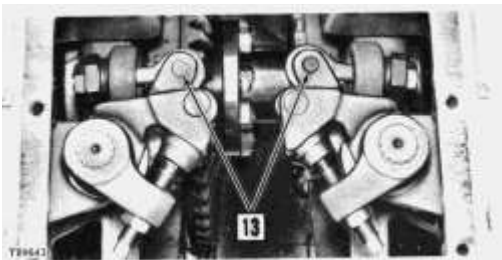

13 Pins.

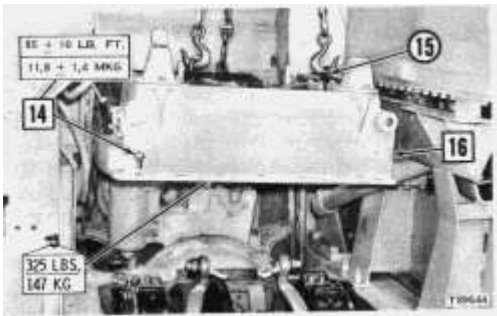

14-Bolts (eighteen). 15-Forged eyebolts (three). Install 3/8"-16 NC forged eyebolts and attach a hoist. 16-Steering clutch case cover.

Steering Clutch And Bevel Gear Shaft Removal

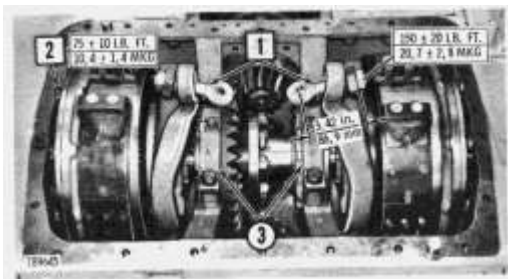

1-Rod ends. When installing rod end and adjusting nut, adjust dimension between center of hole in rod end and outer face of adjusting nut to dimension shown. Lock with lock nut. 2-Bolts (twenty). 3-Bearing caps. The caps are marked L and R and should be installed on the correct side of the machine.

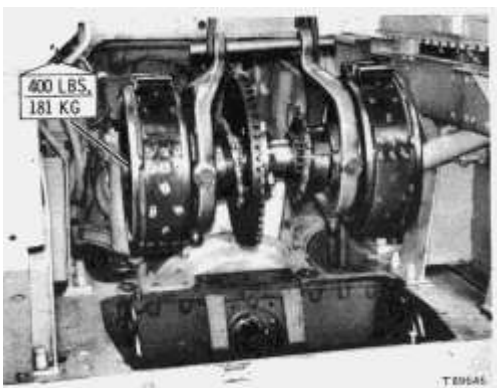

Steering Clutch Removal

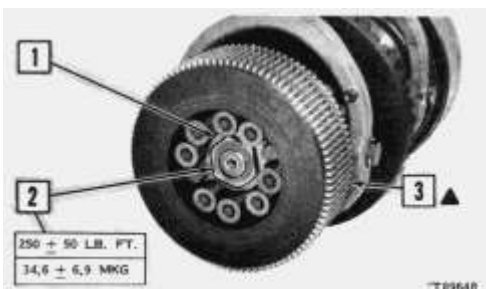

1-Lock. 2-Nut. Loosen until there is .25 in. (6,4 mm) between nut and hub. 3-Steering clutch, bearing and yoke. Pull

the steering clutch from the shaft by using a 7F9540 Hydraulic Puller, 6F25 or 3S6224 Pump Group, 8B7548 Push Puller, two 8B7556 Adapters and an 8B7561 Step Plate.

Steering Clutch Installation

Be certain the splines on the bevel gear shaft and in the steering clutch driving drum are clean, dry and free from burrs.

1. With the splines meshing, push the clutch onto the shaft as far as possible by hand.
2. Using a 7M7236 Adapter Group, 7F9540 Hydraulic Puller and 6F25 or 3S6224 Pump Group, press the steering clutch driving drum onto the bevel gear shaft with a pressure of 15-20 tons (13,6 -18,1 M. tons). The distance between the face of the drum and the shoulder of the shaft must then be $.12 \pm .03$ in. ($3,0 \pm 0,8$ mm).
3. Install the steering clutch retaining nut. Tighten to a torque of 250 ± 50 lb. ft. ($34,6 \pm 6,9$ mkg). Install the lock.

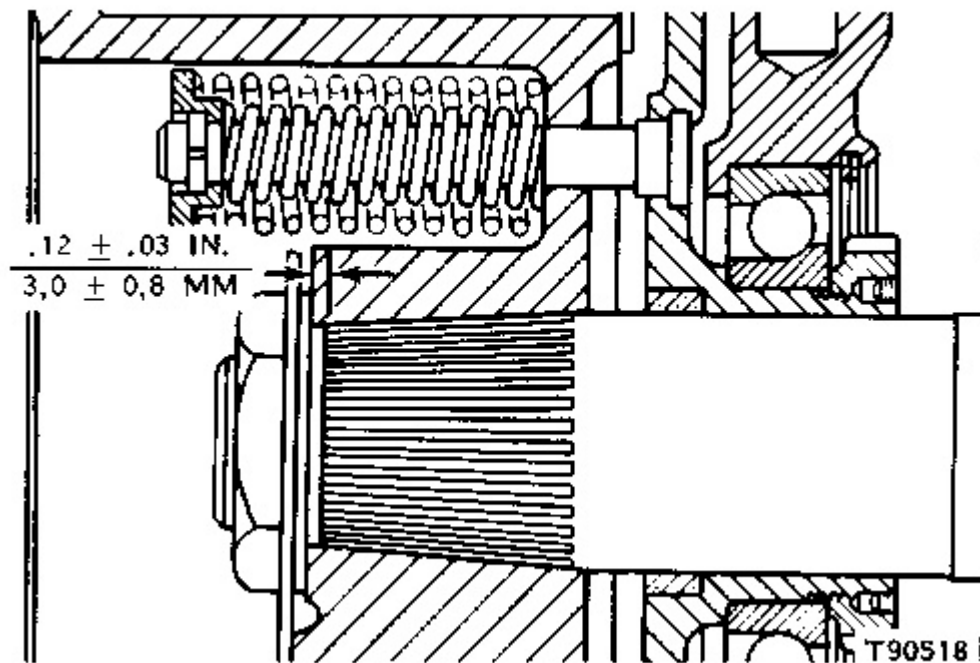

Steering Clutch Disassembly

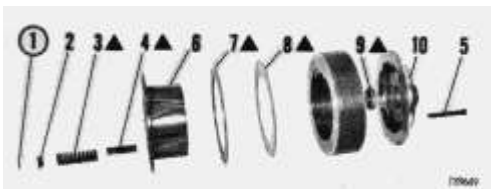

To remove or install locks (1) use a 7F9540 Hydraulic Puller, 6F25 or 3S6224 Pump Group, 8B7548 Push Puller, two 8B7556 Adapters, 8B7561 Step Plate and 7S8431 Spring Compressor Plate.

NOTE: If new discs (8) are installed, no precaution is necessary as to which face is up. If the same discs are installed, they must be replaced with the same face up. Place the top discs on the bottom of the stack.

Steering Clutch Release Bearing Removal And Installation

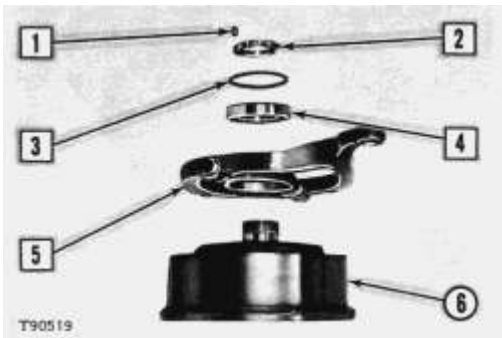

1-Setscrews (two). 2-Nut. 3-Retaining ring. 4-Thrust bearing. 5-Bearing cage and yoke. 6-Steering clutch (shown with drum installed to protect and align teeth of discs).

NOTE: The bearing (4) is a thrust bearing and must be installed with the widest side of the inner race next to the nut.

1. Assemble the parts in the reverse order of disassembly.
2. After the nut has been secured, drill two diametrically opposed $13/64$ in. holes, $.38$ in. ($9,6$ mm) deep on the parting line of the plate assembly and the nut.
3. Using a $1/4$ "-20 NC tap, tap each hole $.25$ in. ($6,3$ mm) deep.
4. Install the two hollow head setscrews.
5. Peen over the nut and plate assembly around the setscrews to retain them.

Bevel Gear Shaft Bearings And Bevel Gear Removal

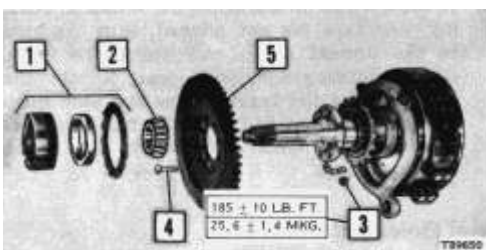

1-Cage, nut and cup. 2-Bearing. The bevel gear shaft bearings can be removed by using an 8B7548 Push Puller, 8B7549 Legs, 8B7551 Bearing Puller Attachment, 7F9540 Hydraulic Puller and a 6F25 or 3S6224 Pump Group. 3-Nuts (eight). 4-Bolts (eight). 5-Bevel gear.

NOTE: Heat the bearings in oil before installing on shaft. The inner race must be seated against the shoulder of the shaft.

Bevel Gear And Pinion Setting

The bevel gear and pinion must be located to obtain the correct tooth contact. The pinion can be moved toward or away from the centerline of the bevel gear and bevel gear shaft with shims located between the pinion shaft bearing cage and the bevel gear case. Adjusting nuts, on each bevel gear shaft bearing cage, permit moving the bevel gear toward or away from the centerline of the bevel pinion shaft. Moving either the bevel gear or the pinion affects both backlash and tooth contact so the two must be adjusted at the same time.

The relative positions of the bevel gear and the pinion gear will vary with different sets. The correct amount of backlash is $.008 \pm .003$ in. ($0,2 \pm 0,07$ mm). When replacing an individual gear or pinion, see the topic, BACKLASH ADJUSTMENT, for correct setting.

The pinion location can be obtained as described in the topic, BEVEL PINION LOCATION.

Preload the bevel gear shaft bearings as outlined in the covering topic before adjusting the backlash or locating the bevel pinion.

Bevel Gear Shaft Bearing Preload

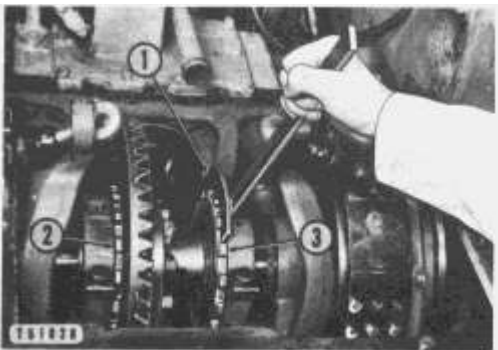

Typical example of bevel gear shaft bearing preload. Illustrated are : 1-7M7239 Wrench. 2-Nut. 3-Nut.

Use a 7M7239 Wrench to tighten the nuts.

Make certain the bevel gear and bevel pinion gear do not bind.

Use a pry bar to make certain there is no bevel gear shaft bearing end clearance.

Backlash Adjustment

The amount of backlash between each bevel gear and pinion set on original installation, is determined at the factory and marked on the outside diameter of the bevel gear. On a replacement gear or pinion, adjust the backlash to $.008 \pm .003$ in. ($0,2 \pm 0,07$ mm).

1. Secure a dial indicator to the bevel gear case as shown.
2. Lock the bevel gear so it cannot rotate.
3. Place the finger of the dial indicator on the pinion gear tooth.
4. Rock the pinion gear back and forth.

5. The amount of backlash is the difference in readings on the dial indicator.
6. Check the backlash at four different locations on the bevel gear, taking the lowest reading as the position to check the backlash.
7. If the reading is too great, decrease the backlash by loosening the right adjusting nut and tightening the left adjusting nut an equal amount.

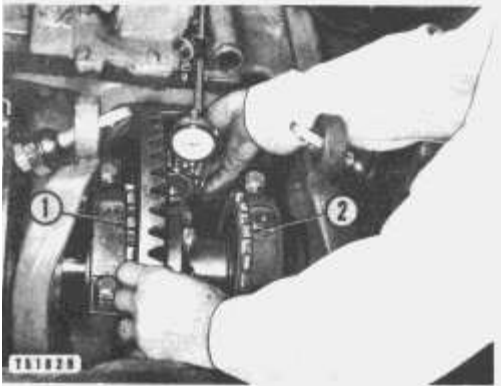

Typical example of checking bevel gear backlash. Illustrated are: 1-Left adjusting nut. 2-Right adjusting nut.

8. To increase backlash, loosen the left adjusting nut and tighten the right adjusting nut an equal amount.

NOTE: Bevel gear shaft bearing preload will be maintained only if the bearing slack caused by loosening one adjusting nut is compensated for by tightening the other adjusting nut an equal amount. See the topic, BEVEL GEAR SHAFT BEARING PRELOAD.

9. If the notches on the adjusting nuts and bearing cage caps are not aligned, turn the nuts to the nearest notch and install the locks. After adjusting the bevel gear, tighten the bolts holding the bearing caps and lock them in place. Tighten and lock the bolts that secure the bevel pinion gear bearing cage to the bevel gear case.

Bevel Pinion Location

If the same pinion shaft is reinstalled in the same bevel gear case, use the same shims between the pinion shaft bearing cage and the bevel gear case that were removed. The pinion can be located by observing the tooth contact pattern made by the pinion gear teeth on the bevel gear teeth. This can be done in the following manner.

Use sufficient shims between the pinion shaft bearing cage and the bevel gear case to align the heel ends of the bevel gear and pinion gear teeth. This will place the pinion in nearly the correct relationship with the bevel gear.

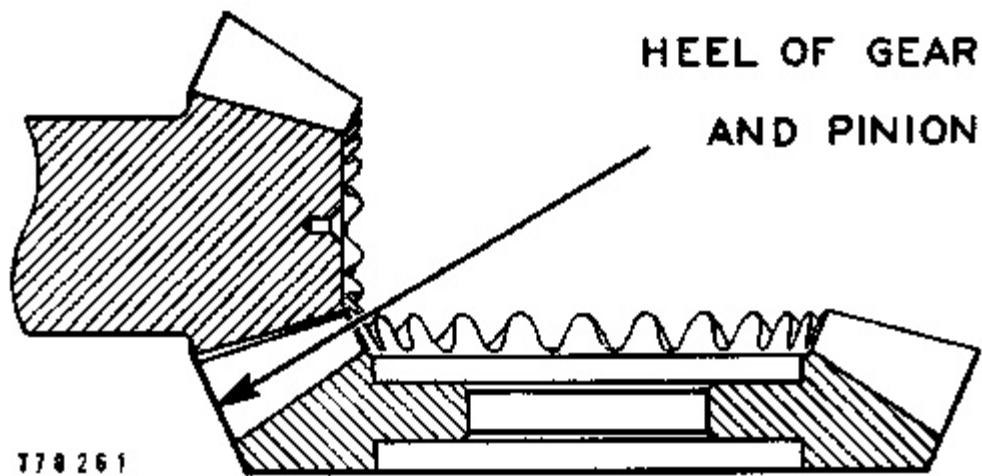

This illustrates aligning the bevel gear and pinion.

Adding shims will move the pinion gear away from the centerline of the bevel gear shaft. Removing shims will move the pinion toward the centerline of the bevel gear shaft.

Adjust the bevel gear backlash as described in the topic, BACKLASH ADJUSTMENT. This should give a very close adjustment.

To further check the adjustment, brush Prussian blue or red lead sparingly on the bevel gear teeth. When the pinion is rotated, the red lead is squeezed away by the contact of the teeth, leaving bare areas of the contacts. Sharper impressions can be obtained by applying a small amount of resistance to the bevel gear while rotating the pinion. When making adjustments, check the convex side of the bevel gear teeth. The reverse or concave side contact should automatically be correct when the convex side is correct.

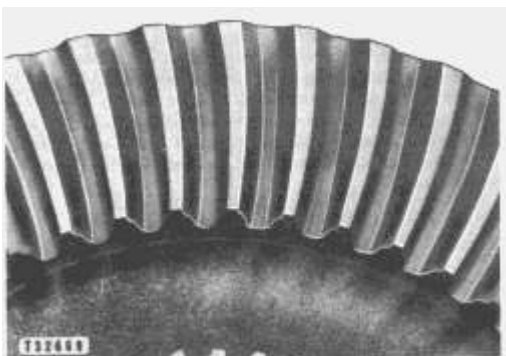

FIG. A - This illustrates proper tooth contact pattern.

With adjustments properly made, the correct tooth contact in Fig. A will be obtained. The area of contact starts near the toe of the gear and extends about 30 per cent of the tooth length. This contact pattern is obtained with no load applied to the gears. This adjustment results in a quiet running bevel gear and pinion set which, because when the load is applied it is distributed over the teeth within the proper area, will give maximum service life. It is permissible for the tooth contact area to be slightly greater on the concave face.

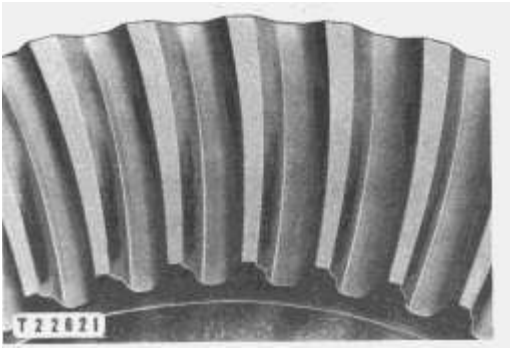

FIG. B - This illustrates short toe contact.

In Fig. B, the pinion is too far away from the centerline of the bevel gear shaft. This causes the teeth to bear on the toe ends of the convex faces and toward the heel end of the concave faces. To correct this, move the pinion toward the gear by removing shims from the bevel pinion bearing cage. Recheck the backlash, changing it if necessary, and again check the tooth contact pattern. To correct the backlash, move the bevel gear away from the pinion.

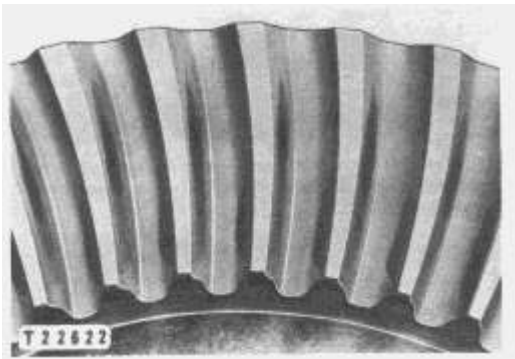

FIG. C - This illustrates short heel contact.

In Fig. C, the pinion is too close to the centerline of the bevel gear shaft. This causes the teeth to bear on the toe ends of the concave faces and the heel ends of the convex faces. To correct, add shims to the bevel pinion bearing cage. Then, recheck the backlash and tooth contact patterns. To correct the backlash, move the bevel gear toward the pinion.

Several adjustments of both the pinion and bevel gear may be necessary before correct tooth contact and backlash are obtained.

Always remember that the backlash will also affect the tooth contact pattern. Therefore, be sure the backlash is properly adjusted before checking the adjustment of the pinion.

Brake Band And Drum Removal And Installation

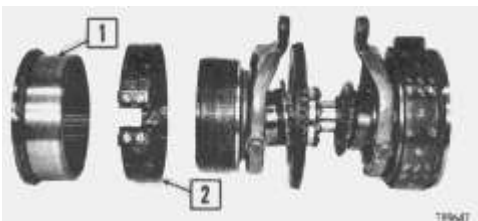

1-Brake drum. 2-Brake band.

Final Drive Pinion Removal

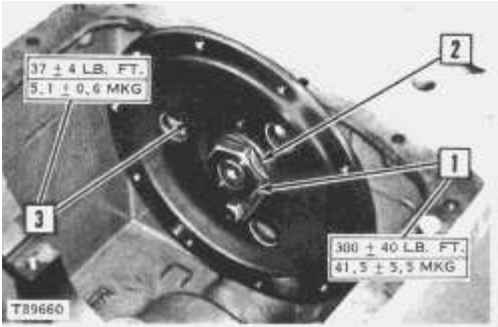

1-Nut. 2-Lock. After removing lock, reinstall nut leaving about .25 in. (6,3 mm) between flange and nut. 3-Bolts (six).

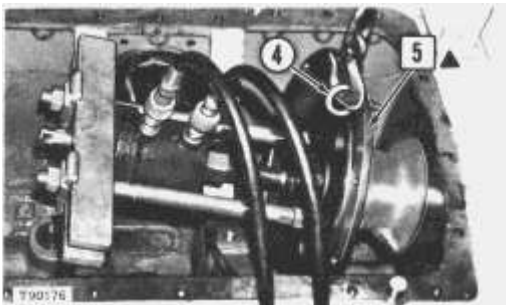

4-3/8"-16 NC forged eyebolt and nut. Attach a hoist. Move the flange and pinion toward the centerline of the machine until the cage clears the inside wall of the clutch case and the flange and pinion can be supported as shown. 5-Brake drum flange. Remove from pinion by using an 8B7548 Push Puller, two 8B7556 Adapters, an 8B7560 Step Plate, a 7F9546 Hydraulic Puller and a 6F25 or 3S6224 Pump Group.

Final Drive Pinion Disassembly

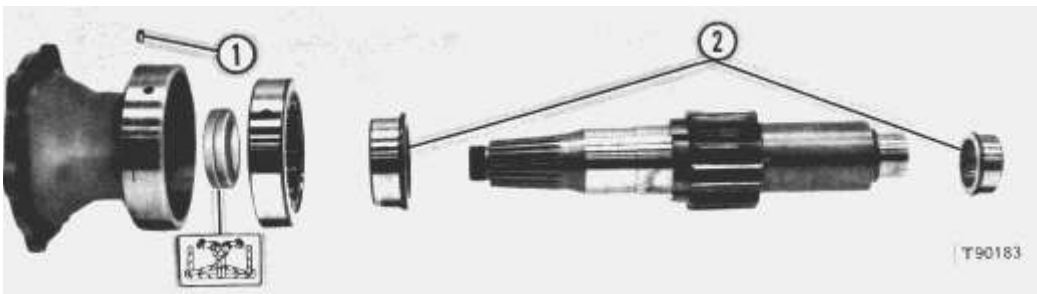

1 Remove dowel by inserting a 1/4"-20 NC bolt into the dowel and pulling the dowel out of the cage.

2 Remove the races with an 8B7548 Push Puller, 8B7551 Bearing Pulling Attachment and an 8B7560 Step Plate.

Final Drive Pinion Installation

Reassemble the final drive pinion and install it in the machine. Press the brake drum flange into place with a force of 15-20 tons (13,6-18,1 M. tons) using a 7M7236 Adapter Group, 7F9540 Hydraulic Puller and a 6F25 or 3S6224 Pump Group.

The distance between the face of the flange and the shoulder of the pinion should be $.12 \pm .03$ in. ($3,0 \pm 0,7$ mm).

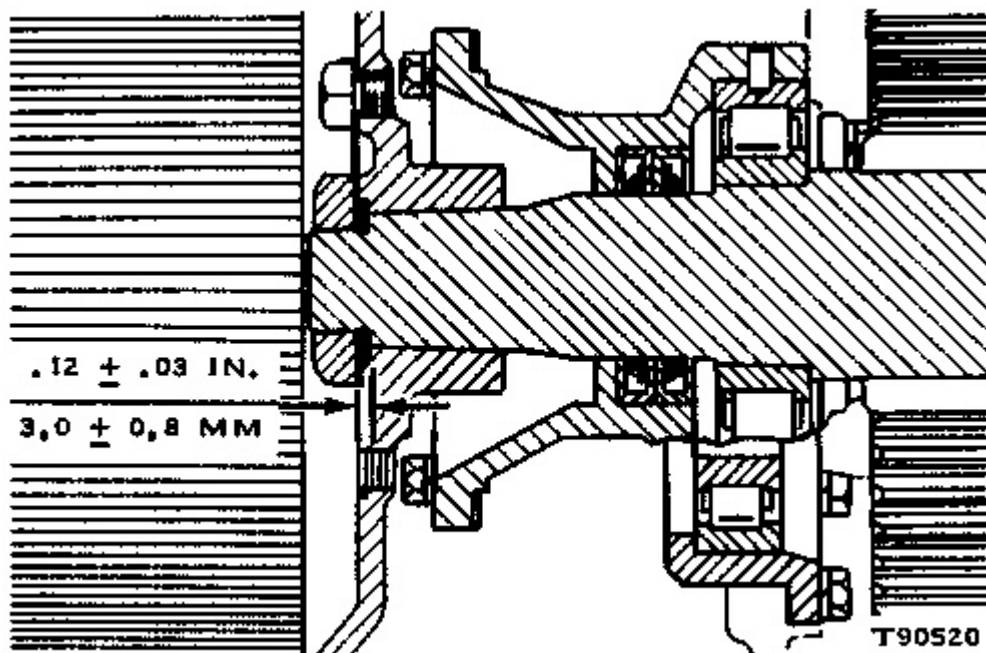

Final Drive Removal And Installation (As A Unit)

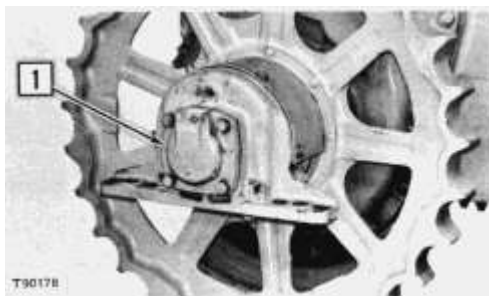

1-Cap.

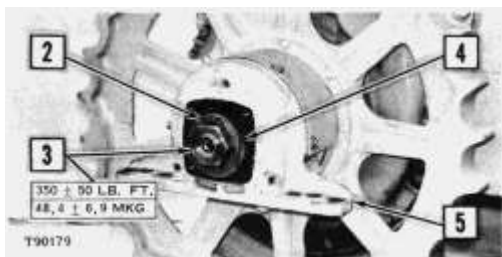

2-Lock. 3-Nut. 4-Washer. 5-Bearing.

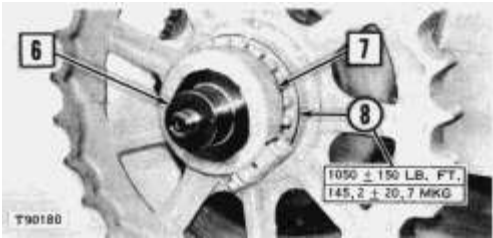

6-Shims. For alignment of track roller frame and sprocket. See ALIGNMENT OF TRACK ROLLER FRAMES. 7-Holder, and bearing cage. 8-Adjusting nut.

NOTE: Replace the nut (3) on the end of the sprocket shaft leaving some space between it and the end of the bearing cage holder. The holder assembly (7) can be removed by turning the nut (8) in a clockwise direction with a 7F9306 Spanner Wrench.

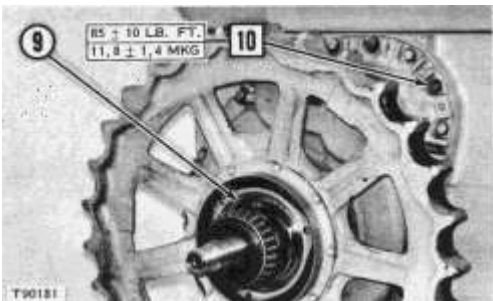

9-Duo-Cone floating seals (two). Remove the Duo-Cone floating seals for their protection. Use 9M5143 Seal Installer to remove or install Duo-Cone seals. One is in the retainer on the sprocket. The other is in a retainer in the adjusting nut. See the GENERAL INSTRUCTIONS for seal removal and installation. 10-Bolts (twenty-four).

11. Attach a hoist to the sprocket. Use two 3/8" -16 NC forcing screws to separate the final drive case from the steering clutch case.

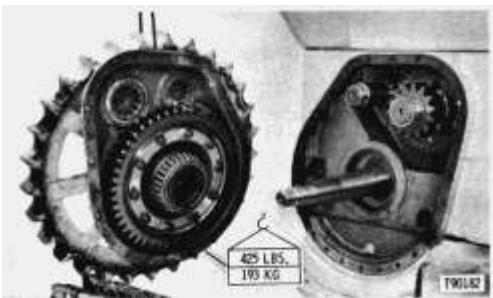

Final Drive Removal And Disassembly

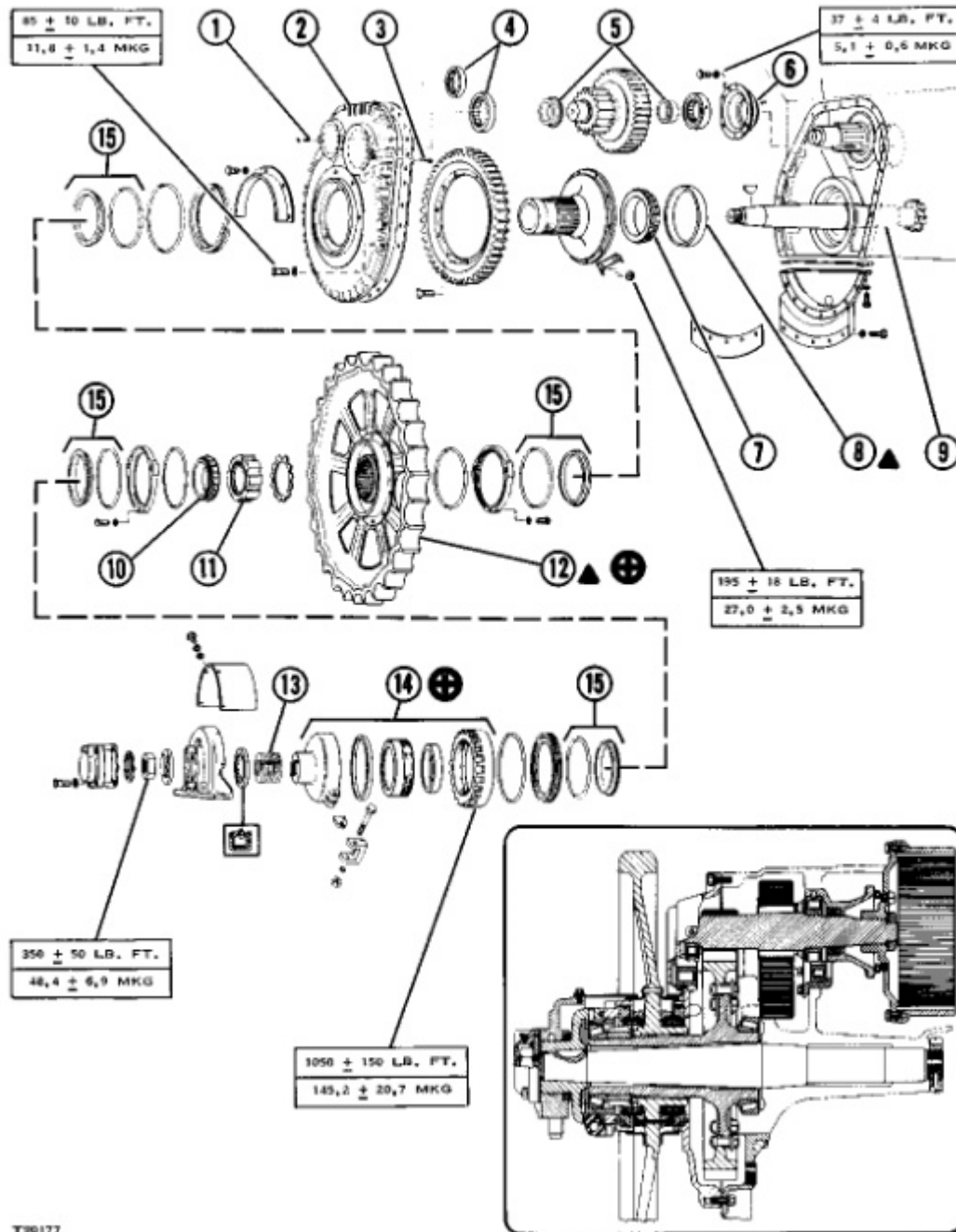

T90177

Sprocket Segment Removal And Installation

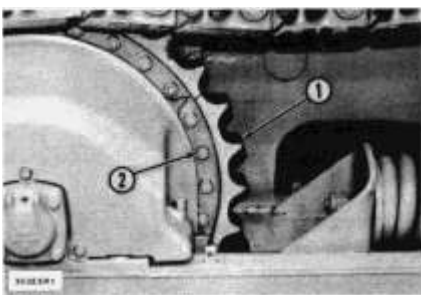

1. Remove sprocket guards.
2. Remove bolts and nuts (2) and remove sprocket segment (1).

3. At installation place machined side of segment (1) towards hub and head of retaining bolt against inside of hub.

4. Lubricate threads of bolts with high pressure lubricant or 9M3710 Anti-Seize Compound and tighten all nuts to 130 ± 30 lb. ft. ($19,0 \pm 4,1$ mkg), then tighten each nut an additional 1/3 turn.

See Tool Selection Chart for tools to remove solid sprocket hubs on later machines.

1, 3, 6 Remove dowels by inserting 1/4"-20 NC bolt into the dowels and pulling them out of the housing.

2 Use two 3/8"-16 NC forcing screws to separate final drive case from steering clutch case.

4 Remove bearings with an 8B7554 Puller and an 8B7552 Forcing Bolt.

5 Remove inner races by heating evenly with a torch so they will expand.

7 Remove cone using an 8H705 Puller.

8 Remove cup by arc welding a bead around its inside diameter causing it to shrink. Install new cup by chilling and driving into bore.

NOTICE

Make certain the ground lead is connected to the bevel gear case to prevent arcing through bearings.

9 Remove the sprocket shaft by removing the retainer nut under the steering clutch case and by using a 6F25 or 3S6224 Pump Group, 7F9831 Cylinder Group, 5F9888 Coupling Adapter, 5F9879 Adapter, 5F9892 Pin and a 5F9890 Sprocket Shaft Puller Group.

10 Remove cone by forcing it off the hub with the sprocket retaining nut. Use a 5F9693 Wrench, to turn the nut. Heat the cone to install on hub.

11 Use nut to force off cone then reinstall nut so there is about .25 in. (6,3 mm) between it and the sprocket.



WARNING

Be sure that the nut is installed as stated in item 11 to prevent the sprocket from jumping off the hub after it has broken loose from the press fit.

12 Remove sprocket using a 6F25 or 3S6224 Pump Group, 7F9831 Cylinder Group, 5F7694 Plug, three 5F9040 Arm Groups and two 7S9484 Spacer assemblies.

13 Shims used to align track roller frame with sprocket. See TRACK ROLLER FRAME ADJUSTMENT.

14



Replace sprocket shaft nut on the sprocket shaft with some space between it and the holder assembly (14). This prevents the holder assembly from jumping off the shaft after it has broken loose from the taper fit.

Turn the final drive adjusting nut clockwise with a 7F9306 Spanner Wrench to remove the bearing cage holder assembly.

15 Use a 9M5143 Seal Installer to remove or install Duo-Cone seals.

Final Drive Assembly

Sprocket Shaft Installation

Using a 5F9889 Plug, 5F9885 Adapter (threaded against the shoulder on the sprocket shaft), and a 5F9892 Pin, drive the sprocket shaft into the bevel gear case (with the key slot facing upward) until the distance between the face of the outer bearing cage holder (hand held in place on the taper of the sprocket shaft) and the parting line between the final drive case and the bevel gear case is $10.34 \pm .062$ in. (262.64 ± 1.57 mm).

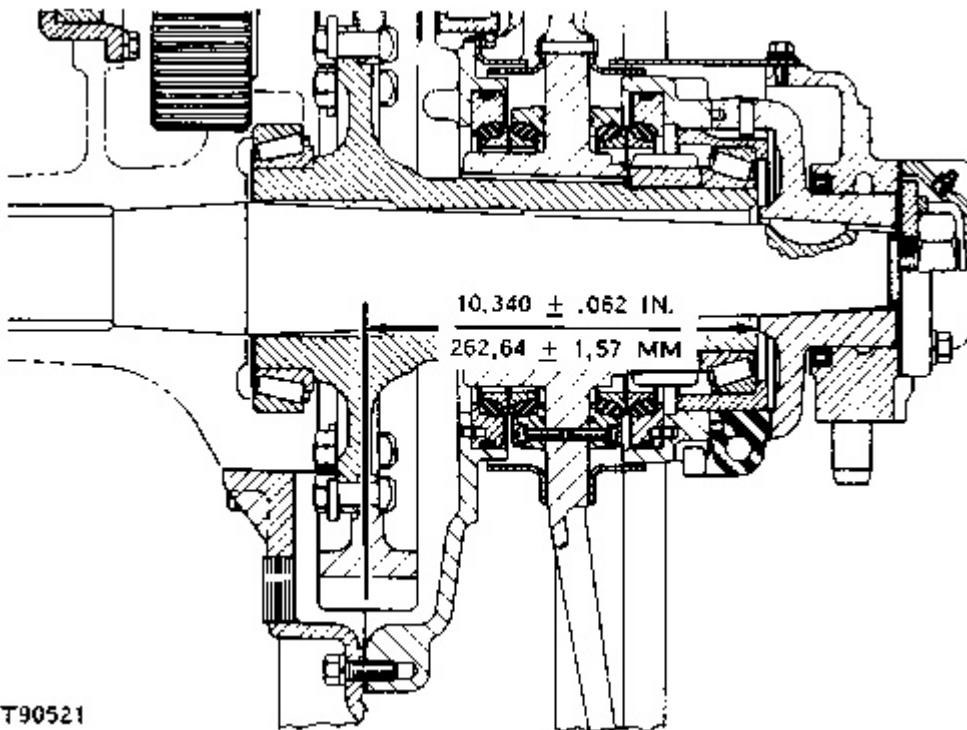

T90521

Thank you so much for reading.
Please click the “Buy Now!”
button below to download the
complete manual.



After you pay.

You can download the most
perfect and complete manual in
the world immediately.

Our support email:

ebooklibonline@outlook.com