

Product: TRACK LOADER

Model: 955L TRACK LOADER 08Y

Configuration: 955L TRACK LOADER / POWER SHIFT / 08Y00001-UP (MACHINE) POWERED BY 3304 ENGINE

Disassembly and Assembly 3304 VEHICULAR ENGINE FOR 955L TRACK-TYPE LOADER

Media Number -SEN7675-00

Publication Date -01/08/1978

Date Updated -12/10/2001

Governor (Sleeve Metering Fuel System)

SMCS - 1264-16; 1264-15

Disassemble Governor

start by:

a) separation of governor from fuel injection pump housing

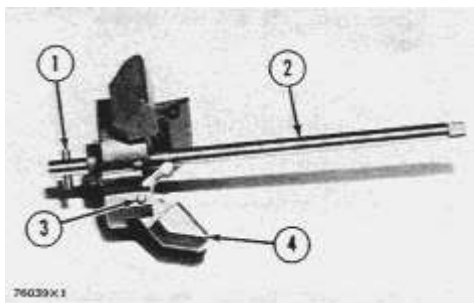

1. Remove shaft (2). Remove pin (1) from shaft.

2. Remove pins (3) from the flyweights. Remove flyweights (4).

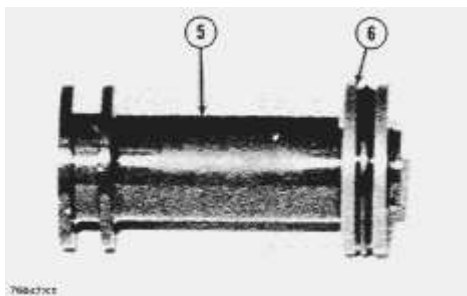

3. Remove ring, races (6) and bearing from the riser (follower) (5).

4. Remove cover (7) and spring (8) from governor housing.

NOTE: There is force on the cover from the spring.

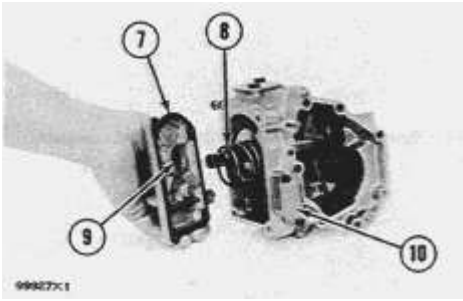

5. Remove seal (9) from cover.

6. Remove cover (10) for the low and high idle adjustments.

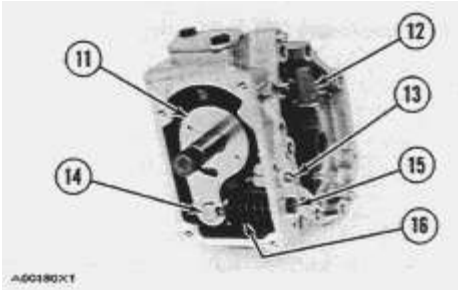

7. Remove locknut and screw (13) for the high idle adjustment.

8. Remove bolt (15) and washers for the low idle adjustment.

9. Remove spring (16) and guide.

10. Remove pin (14) and plate (11).

11. Remove shaft (12) from the housing.

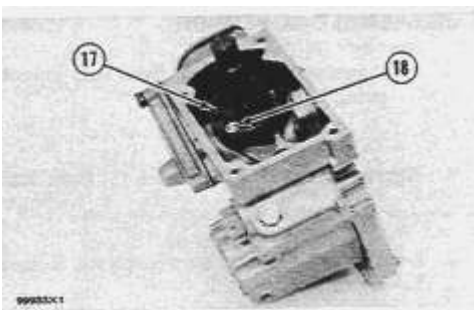

12. Remove pin (18) and two spacers (17) from shaft.

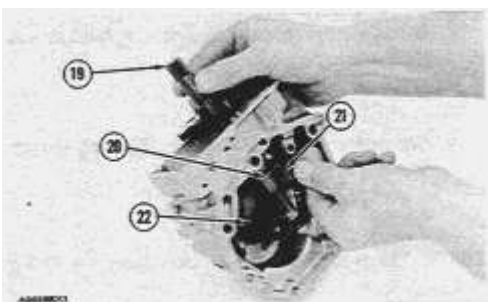

13. Remove shaft (19) from the governor housing.

14. Remove washer (20) and levers (21) and (22) from governor housing.

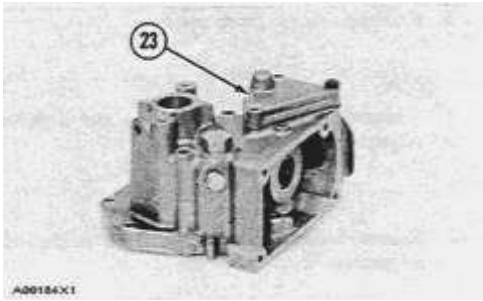

15. Remove cover (23) from governor housing.

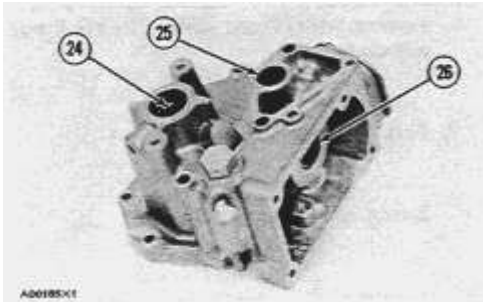

16. Remove seal (25) and bearing.

17. Remove seals (24) and (26) from governor housing.

Assemble Governor

Tools Needed		A	B
1P529	Handle	1	1
1P457	Drive Plate		1
1P471	Drive Plate		1

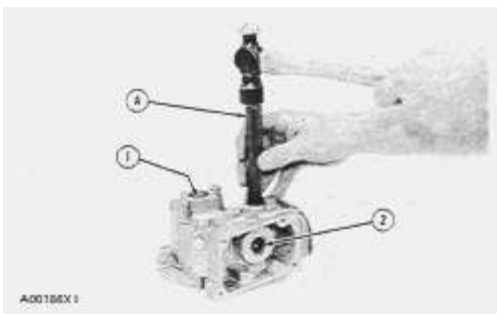

1. Install bearing and seal in the housing with tool (A). The lip of the seal must be toward the bearing.

2. Install seal (1) in housing with tool (A). The lip of seal must be toward inside of housing.

3. Install seal (2) in housing with tooling (B). The lip of seal must be toward the inside of housing.

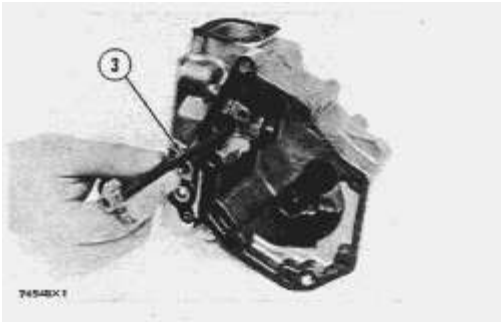

4. Install shaft (3) in the housing.

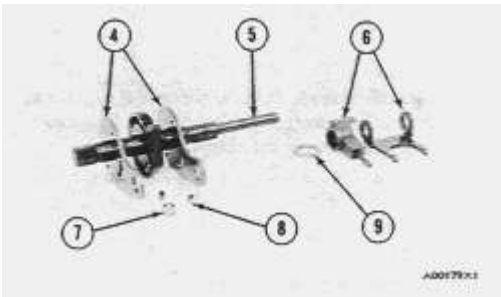

5. Install plates (4), spacers (8) and pin (7) on shaft.

6. Install shaft (5) in housing and through washer (9) and levers (6).

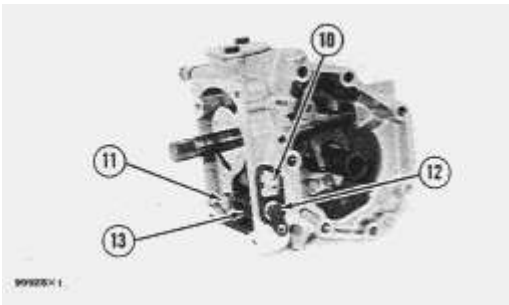

7. Install pin (11) in holes of the plates.

8. Install screw (10) and locknut for high idle adjustment.

9. Install spring (13) and guide.

10. Install bolts (12) and washer for low idle adjustment.

NOTICE

After the fuel injection pump housing and governor have been installed on the engine, make an adjustment for the high and low idle. See GOVERNOR ADJUSTMENT as shown in TESTING AND ADJUSTING.

11. Push plate and pin (11) over toward the bolt (12) and tighten the bolt.

12. Install seal in cover with tooling (B). The lip of seal must be toward the inside.

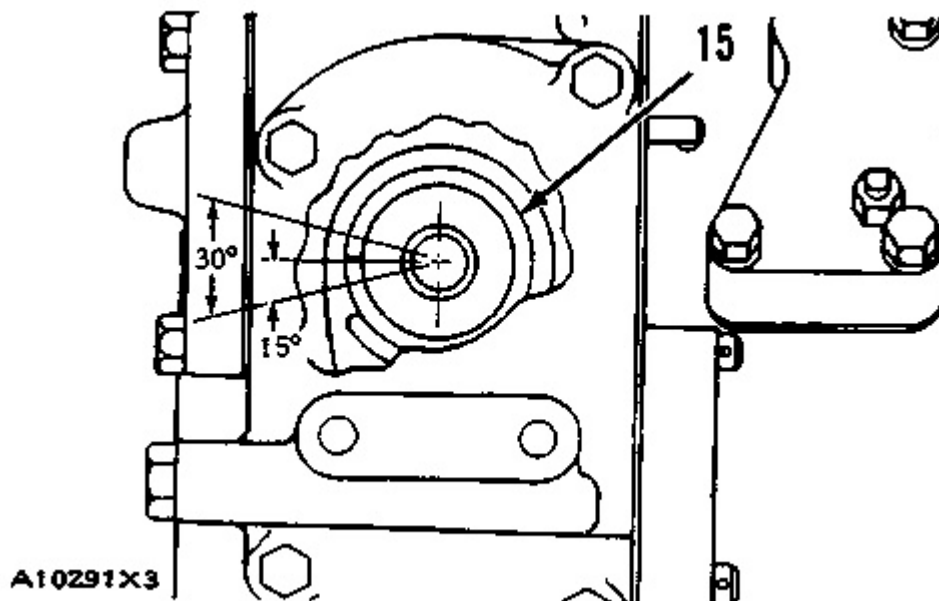
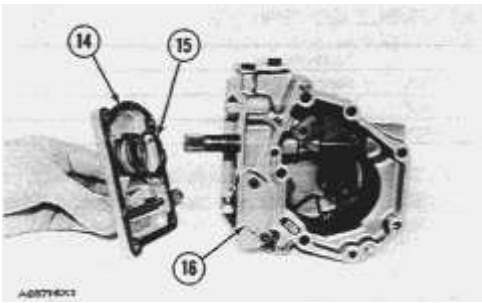

13. Install spring (15) in the cover. Install cover (14) on housing.

NOTICE

The spring (15) must be installed with the end of spring as shown.

14. Install cover (16) for the idle adjustment screws.

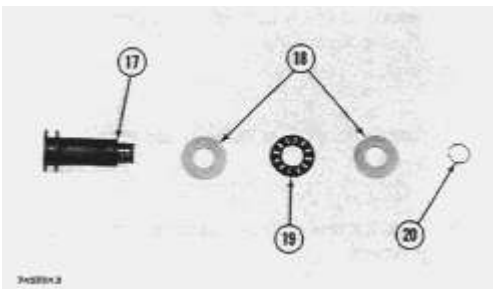

15. Install bearing (19) between the races (18) on riser (follower) (17). Install ring (20) that holds the washers on the riser (follower).

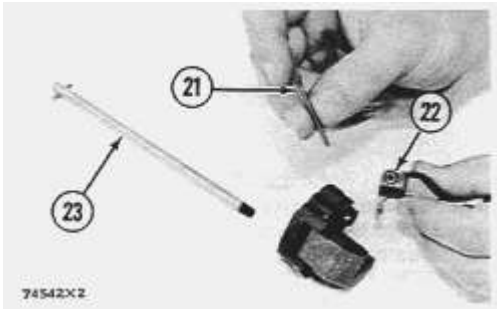

16. Install pin in shaft (23).

17. Install flyweights (22) and pin (21).

18. Install shaft (23) in the flyweight assembly.

end by:

a) connection of governor to fuel injection pump housing

Product: TRACK LOADER

Model: 955L TRACK LOADER 08Y

Configuration: 955L TRACK LOADER / POWER SHIFT / 08Y00001-UP (MACHINE) POWERED BY 3304 ENGINE

Disassembly and Assembly 3304 VEHICULAR ENGINE FOR 955L TRACK-TYPE LOADER

Media Number -SEN7675-00

Publication Date -01/08/1978

Date Updated -12/10/2001

Governor (Compact Fuel System)

SMCS - 1264-16; 1264-15

Disassemble Governor

start by:

a) separation of governor from fuel injection pump housing

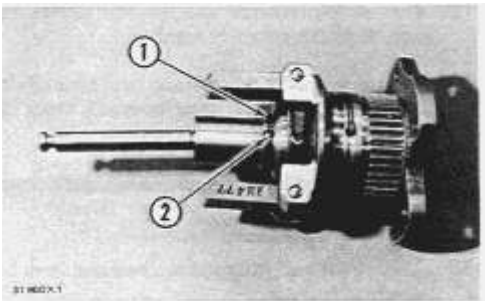

1. Remove ring (1) and dowel (2) that hold the seat to the piston assembly.

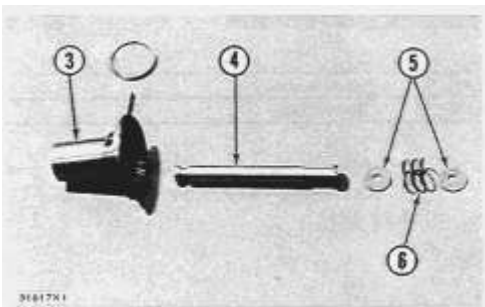

2. Remove seat (3), governor bolt (4), washers (5) and spring (6) from the weight assembly.

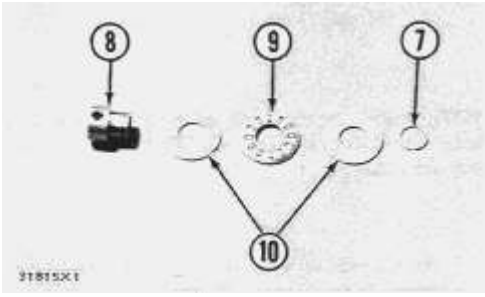

3. Remove sleeve (8) from the weight assembly. Remove ring (7), bearing (9) and bearing races (10) from sleeve (8).

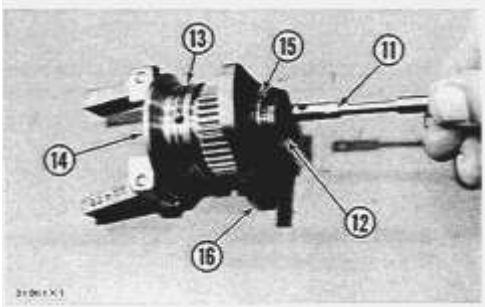

4. Remove valve (11) from piston (12).

5. Remove lock (13) and remove weight assembly (14) from cylinder (16).

6. Remove piston (12) and sleeve (15) from cylinder (16). Remove the O-ring seal from sleeve (15).

7. Remove the high idle and low idle screws and seals from the governor housing.

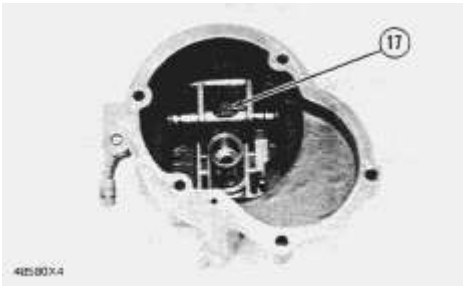

8. Remove bolt (17), the lock and band assembly to remove the shaft and lever assembly from the governor housing.

9. If necessary, remove the pin, spring and plunger (detent assembly) from the lever assembly.

10. Remove the seal, plug and two bearings from the governor housing.

Assemble Governor

Tools Needed		A
1P510	Driver Group	1

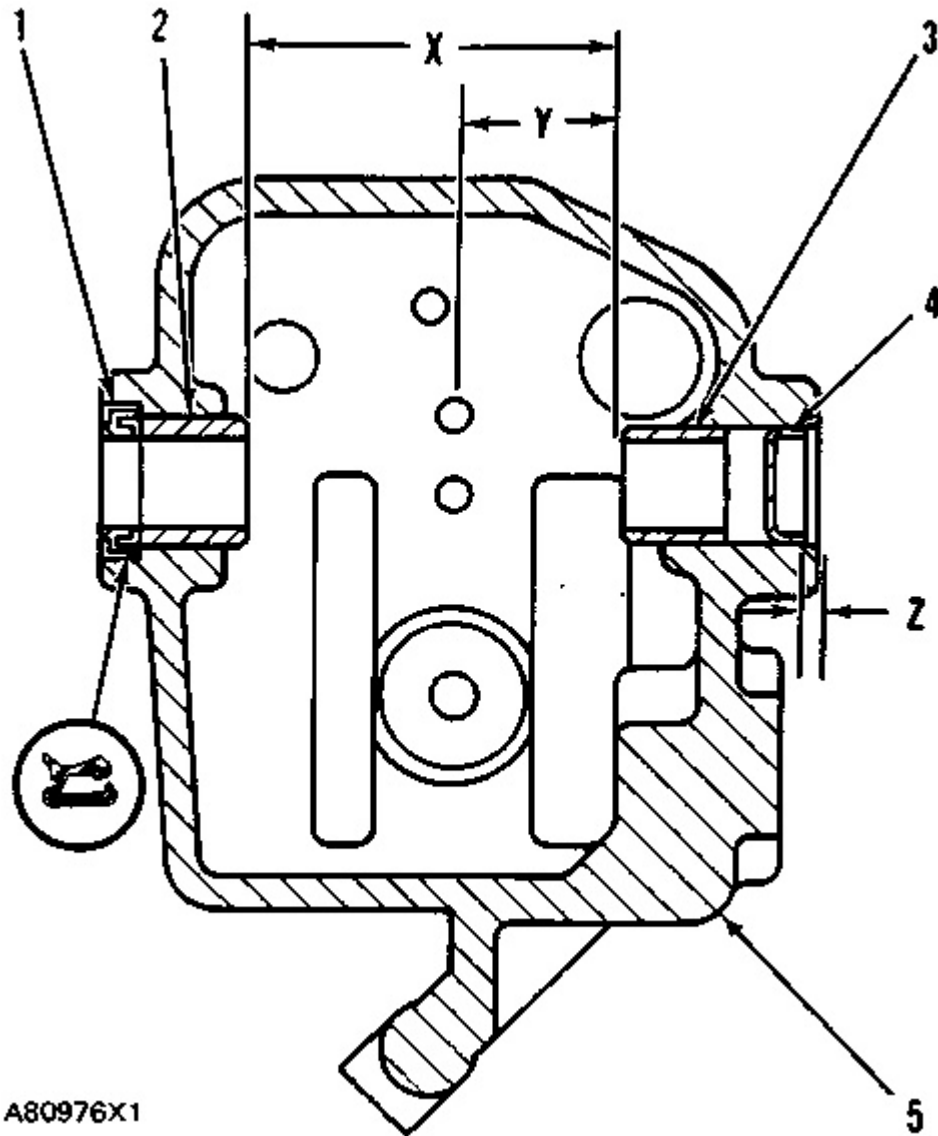

1. Install bearing (3) in housing (5) with tool group (A). Make sure dimension (Y) is 1.073 in. (27.25 mm).

2. Install bearing (2) in housing (5) with tool group (A) until dimension (X) is $2.385 \pm .005$ in. (60.58 ± 0.13 mm).

NOTE: Make sure the inside diameter of bearings (2) and (3) is $.6210 \pm .0013$ in. (15.773 ± 0.033 mm) after they are installed.

3. Install plug (4) with tool group (A) until dimension (Z) is .09 in. (2.29 mm).

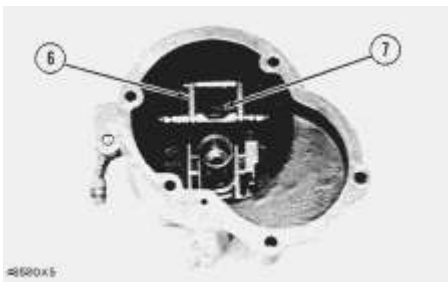

4. Install the plunger, spring and pin for the detent assembly in lever assembly (6). Put lever assembly (6) and shaft in position and install bolt (7) and the lock.
5. Install the high idle and low idle screws and seals in the governor housing.

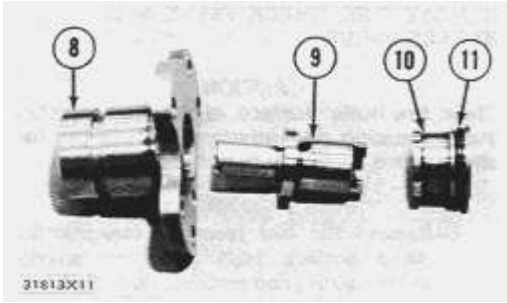

5. Install the O-ring seal (11) on sleeve (10).
6. Install piston (9) and sleeve (10) in cylinder (8).

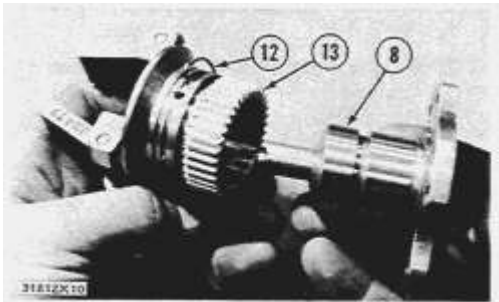

7. Put weight assembly (13) in position on cylinder (8) and install lock (12) to hold the unit together.

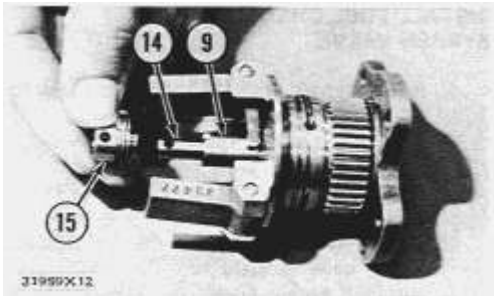

8. Install valve (14) in piston (9).
9. Install the bearing and two races on sleeve (15). Install the ring to hold the bearing assembly on sleeve (15). Install sleeve (15) on valve (14) as shown.

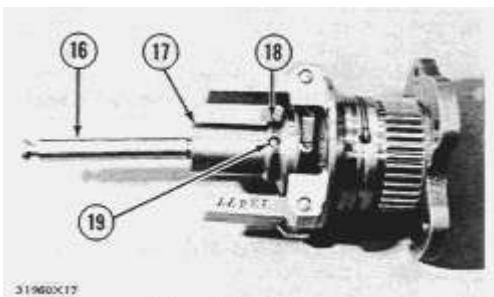

10. Install governor bolt (16) and spring (with a washer on each end) in seat (17). Put seat (17) in position on sleeve (15) and valve (14). Install pin (19) to hold the seat, sleeve and valve together. Install ring (18) to hold pin (19) in position.

end by:

a) connection of governor to fuel injection pump housing

b) install fuel injection pump housing and governor

c) make rack setting and governor adjustment (See FUEL RACK SETTING AND GOVERNOR ADJUSTMENTS in TESTING AND ADJUSTING section)

Product: TRACK LOADER

Model: 955L TRACK LOADER 08Y

Configuration: 955L TRACK LOADER / POWER SHIFT / 08Y00001-UP (MACHINE) POWERED BY 3304 ENGINE

Disassembly and Assembly 3304 VEHICULAR ENGINE FOR 955L TRACK-TYPE LOADER

Media Number -SEN7675-00

Publication Date -01/08/1978

Date Updated -12/10/2001

Fuel Check Valve And Bypass Valve (Sleeve Metering Fuel System)

SMCS - 1264-16; 1264-15

Remove Fuel Check Valve And Bypass Valve

NOTICE

Clean the outer surface of the fuel injection pump housing and governor before the fuel check valve and bypass valve are removed.

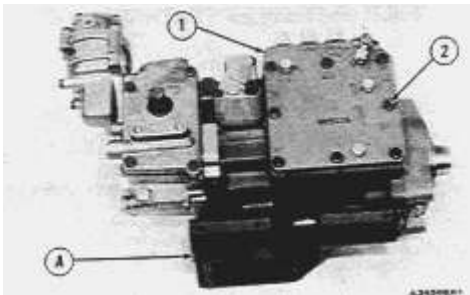

1. Remove the fuel from the fuel injection pump housing. Install the fuel injection pump housing and governor on tool (A).
2. Remove eight bolts (2). Remove cover (1).

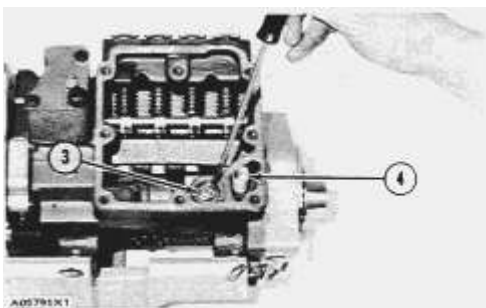

3. Remove check valve (3).
4. Remove spring (4) and the bypass valve.

Install Fuel Check Valve And Bypass Valve

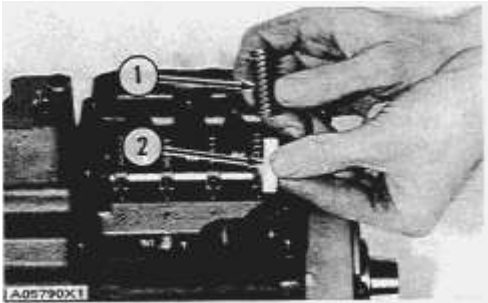

1. Install bypass valve (2) and spring (1) in the fuel injection pump housing.

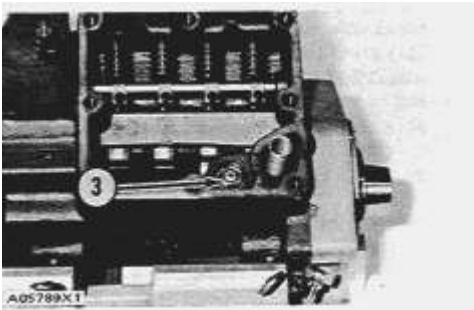

2. Install check valve (3) in the fuel injection pump housing. Make sure the check valve is installed evenly in the fuel injection pump housing.

NOTE: Do not install a check valve that is bent.

3. Put the cover in position on the fuel injection pump housing. Make sure the spring on the bypass valve is in the cover. Install the eight bolts that hold the cover in position.
-

Product: TRACK LOADER

Model: 955L TRACK LOADER 08Y

Configuration: 955L TRACK LOADER / POWER SHIFT / 08Y00001-UP (MACHINE) POWERED BY 3304 ENGINE

Disassembly and Assembly 3304 VEHICULAR ENGINE FOR 955L TRACK-TYPE LOADER

Media Number -SEN7675-00

Publication Date -01/08/1978

Date Updated -12/10/2001

Fuel Injection Pumps (Sleeve Metering Fuel System)

SMCS - 1251-16; 1251-11; 1251-12; 1251-15

Remove Fuel Injection Pumps

Tools Needed		A	B
2P8315	Bracket Assembly	1	
8S2243	Wrench		1

start by:

a) remove fuel injection pump housing and governor

NOTICE

Thoroughly clean the outside of the fuel injection pump housing before the fuel injection pumps are removed.

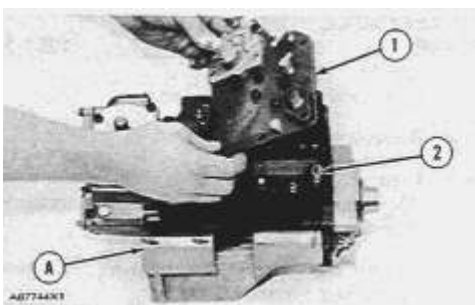

1. Put the pump housing in position on tool (A). Remove cover (1) from the pump housing. Remove spring (2) for the bypass valve.

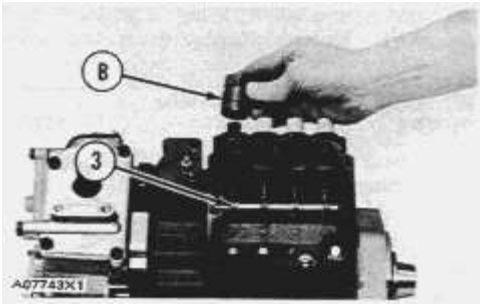

2. Loosen the bushing from the pump housing with tool (B).

NOTE: Do not loosen screws (3). If the screws are loosened, the fuel pump adjustment will be changed.

3. Remove the fuel injection pump from the housing. The sleeve on the plunger will slide off the lever as the pump is removed.

Install Fuel Injection Pumps

Tools Needed		A
8S2243	Wrench	1

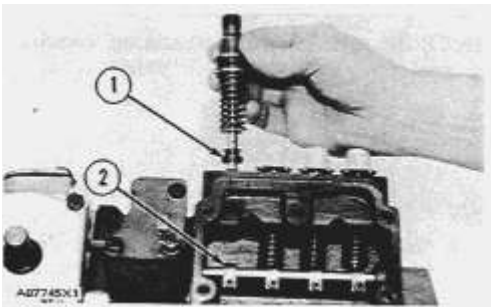

1. Put the fuel injection pump in the bore in the pump housing so that sleeve (1) is engaged with lever (2).

NOTICE

If the screws in the levers have been loosened, an adjustment must be made for the fuel pumps. See FUEL PUMP CALIBRATION as shown in TESTING AND ADJUSTING.

2. Tighten the bushing for the fuel pump with wrench (A) to a torque of 70 ± 5 lb.ft. (95 ± 7 N·m).

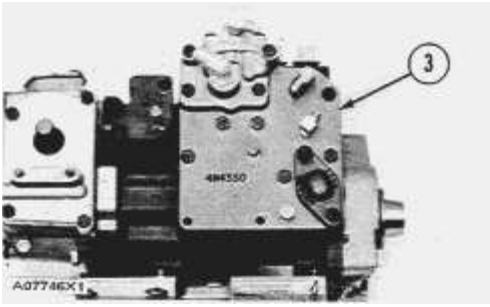

3. Install the spring for the bypass valve. Install cover (3) and make sure the spring is in correct position in the cover.

end by:

a) install fuel injection pump housing and governor

Disassemble Fuel Injection Pumps

start by:

a) remove fuel injection pumps

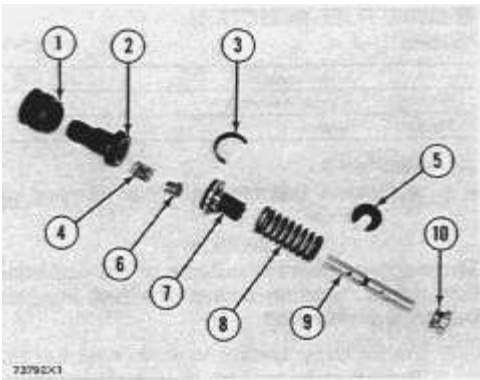

1. Remove the bushing (1) from the bonnet (2).

2. Remove the ring (3) from the bonnet and barrel (7). Remove the check valve (6) and spring (4) from the bonnet.

3. Remove the spring (8) and washer (5). Remove the plunger (9) and sleeve (10).

NOTE: Keep the plunger and sleeve with their respective barrel for installation. Do not use plungers, sleeves and barrels with other plungers, sleeves and barrels.

Assemble Fuel Injection Pumps

Buy Now



Our support email:

ebooklibonline@outlook.com