

Product: WHEEL LOADER

Model: 962G II WHEEL LOADER AXY

Configuration: 962G II Wheel Loader AXY00001-UP (MACHINE) POWERED BY 3126B Engine

Disassembly and Assembly

950G Series II and 962G Series II Wheel Loaders and IT62G Series II Integrated Toolcarrier Power Train

Media Number -REN4311-04

Publication Date -01/12/2004

Date Updated -09/12/2004

i04904939

Transmission Planetary - Disassemble

SMCS - 3160-015

Disassembly Procedure

Table 1

Required Tools			
Tool	Part Number	Part Description	Qty
A	138-7575	Link Bracket	2
B	1P-2420	Transmission Repair Stand	1
C	136-1452	Retaining Ring Pliers As	1
D	5P-5197	Retaining Ring Pliers As	1
E	1P-1863	Retaining Ring Pliers As	1
F	1P-0520	Driver Gp	1
G	8B-7551	Bearing Puller Gp	1

Start By:

- A. Separate the torque converter from the transmission.
-

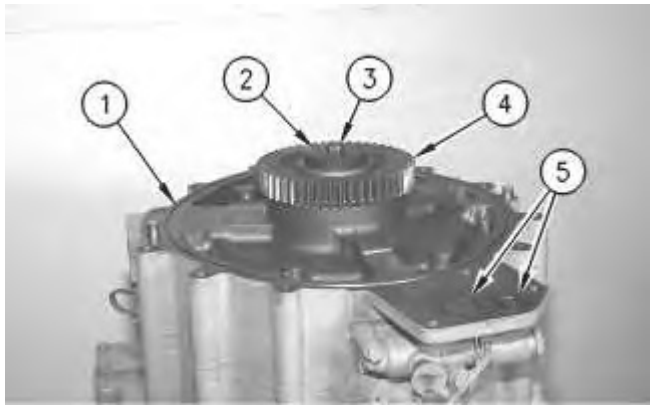

Illustration 1

g00324683

1. Remove O-ring seals (1) and (5) from the housing.
2. Remove bolt (3) , retainer (2) , and drive gear (4) from the end of the input shaft.

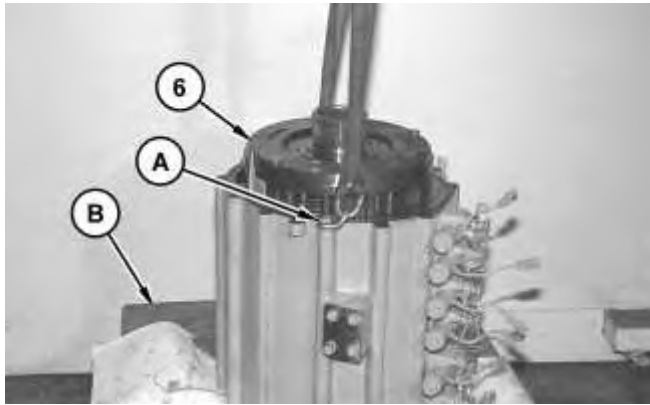
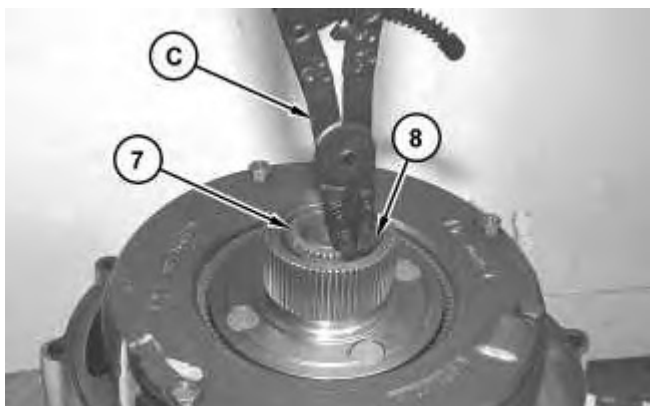

Illustration 2

g01174662

3. Use Tooling (A) and a suitable lifting device to position the transmission on Tooling (B) , as shown.



4. Use Tooling (C) to remove retaining ring (8) from output shaft (7) .

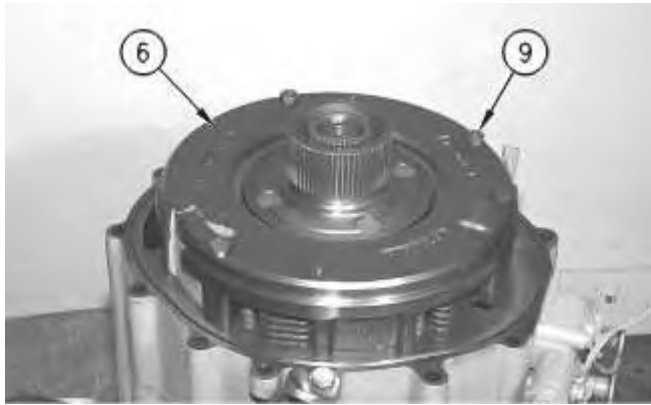

Illustration 4

g00324690

5. Remove four bolts (9) and No. 6 clutch housing (6) . Mark the location of the long bolt.

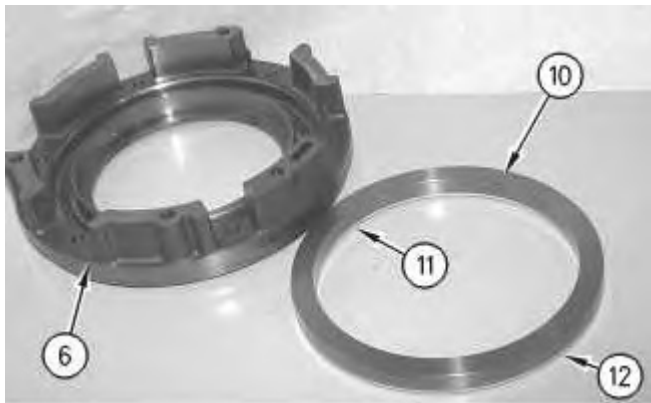

Illustration 5

g00324691

6. Remove clutch piston (10) from No. 6 clutch housing (6) .
 7. Remove seal rings (11) and (12) from clutch piston (10) .
-



Illustration 6

g03078253



Illustration 7

g03063016

8. Remove upper clutch plate (13) , and remove springs (14) and remove reaction dowels (15) .



Illustration 8

g03063037

9. Remove clutch plates (16) and friction discs (17) .

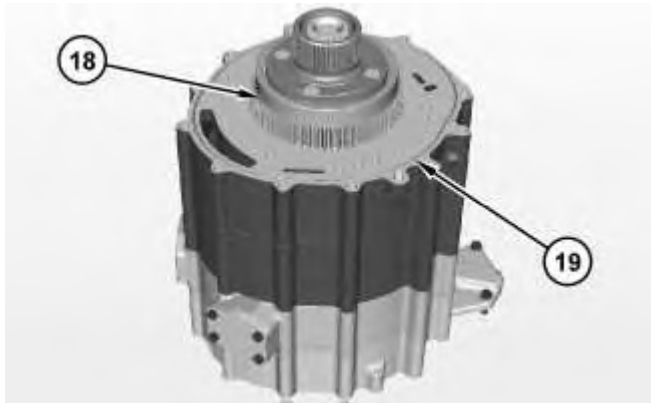

Illustration 9

g03063156

10. Remove ring gear (18) , and remove O-ring seal (19) .

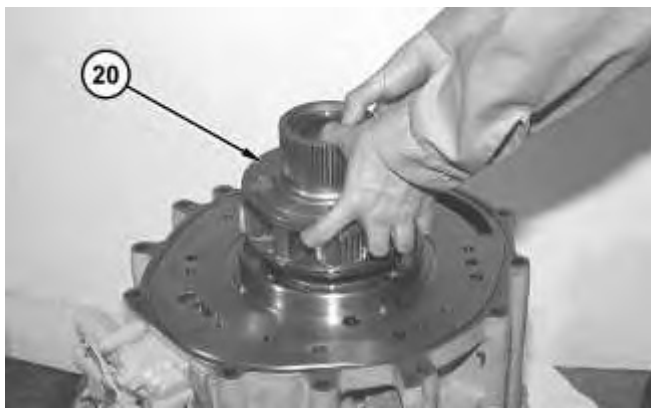

Illustration 10

g03063116

11. Remove carrier assembly (20) .



12. Remove metal seal ring (21) from the carrier assembly.



Illustration 12

g03063497

13. Use a suitable hammer and a punch to push the spring pins through carrier assembly (20) and into planetary shafts (22) .

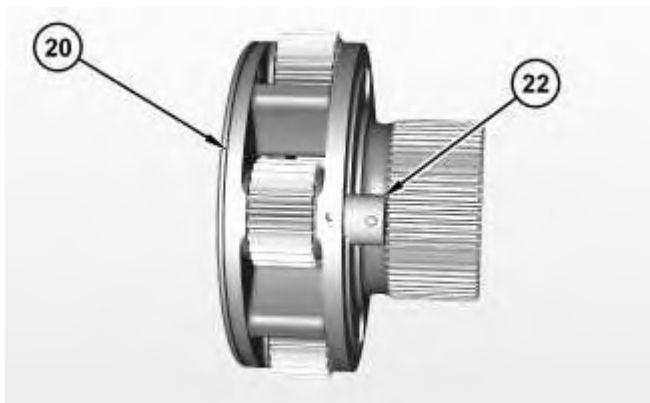

Illustration 13

g03066604

14. Use a suitable hammer and a punch to remove planetary shafts (22) from carrier assembly (20) .
-

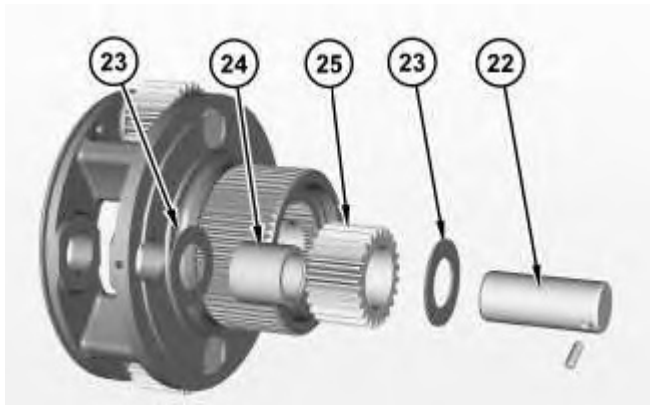

Illustration 14

g03066621

15. Remove thrust discs (23) , and remove planetary gears (25) , and remove bearings (24) from the carrier assembly. Remove the spring pins from planetary shafts (22) .

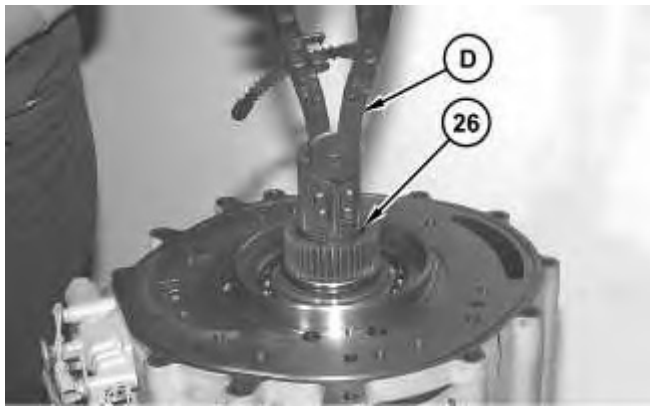

Illustration 15

g03063483

16. Use Tooling (E) to remove retaining ring (27) from the output shaft.



Illustration 16

g01174667

17. Use Tooling (E) to remove retaining ring (27) from the output shaft.



Illustration 17

g01174668

18. Use Tooling (A) and a suitable lifting device to remove housing (28) and the O-ring seal. The weight of housing (28) is approximately 29 kg (64 lb).

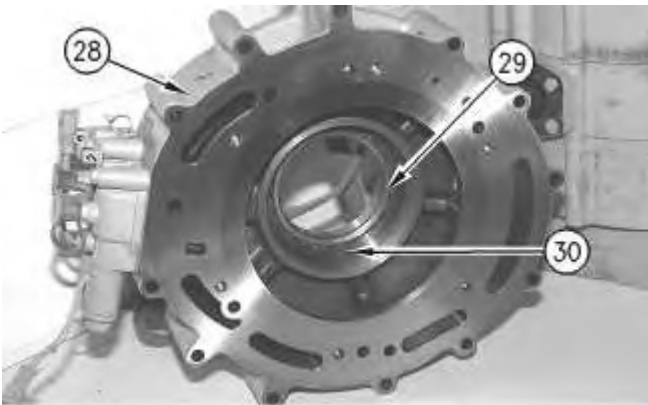

Illustration 18

g00339593

19. Remove retaining ring (30) and bearing (29) from housing (28) .
-

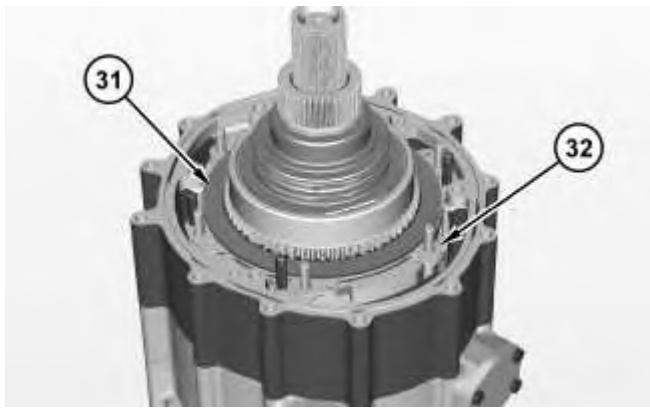

Illustration 19

g03078198

20. Remove friction discs (31) and clutch plates (32) and remove the springs.

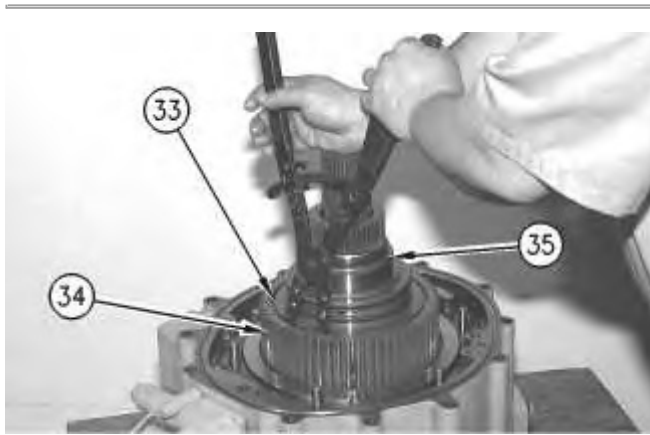

Illustration 20

g00324823

21. Use Tooling (C) to compress retaining ring (33) . Remove clutch housing (35) from ring gear (34) .



Illustration 21

g00324824

22. Use Tooling (C) to remove retaining ring (33) from clutch housing (35) .

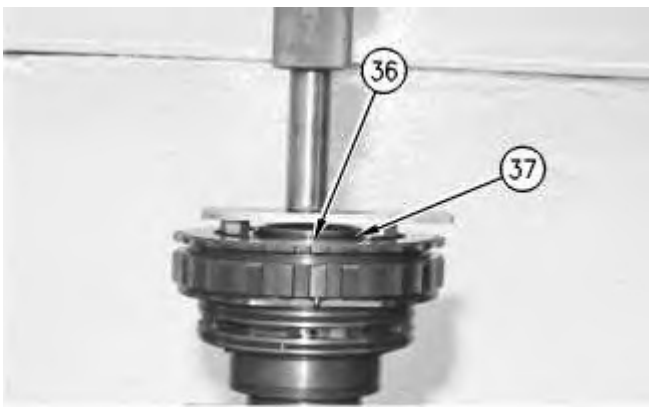

Illustration 22

g00324825

23. Use steel spacers and a press to apply pressure to retainer plate (36) . Remove retaining ring (37) from the clutch housing.

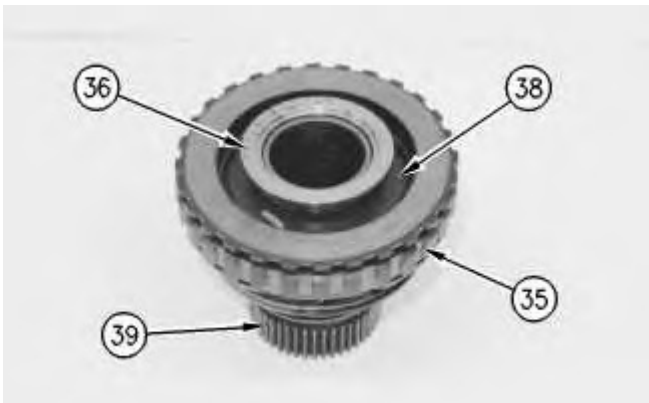

Illustration 23

g00324826

24. Remove retainer plate (36) from sun gear shaft (39) . Remove disc springs (38) from clutch housing (35) .

25. Remove clutch housing (35) from sun gear shaft (39) .

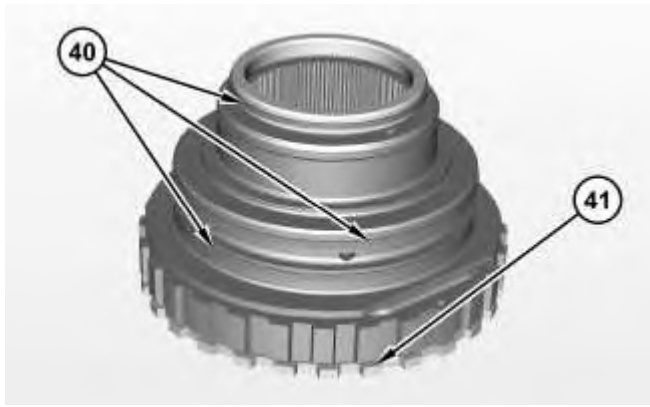

Illustration 24

g03066717

26. Remove seal rings (40) and piston (41) from the clutch housing.

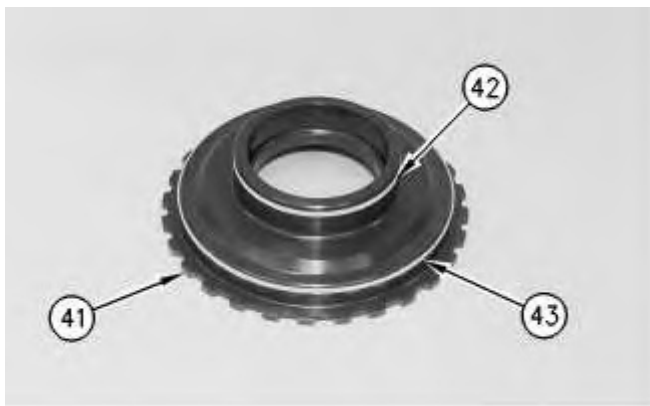

Illustration 25

g00339654

27. Remove seal ring (42) and seal ring (43) from piston (41) .



Illustration 26

g00324828

28. Remove retaining ring (44) from the output shaft.

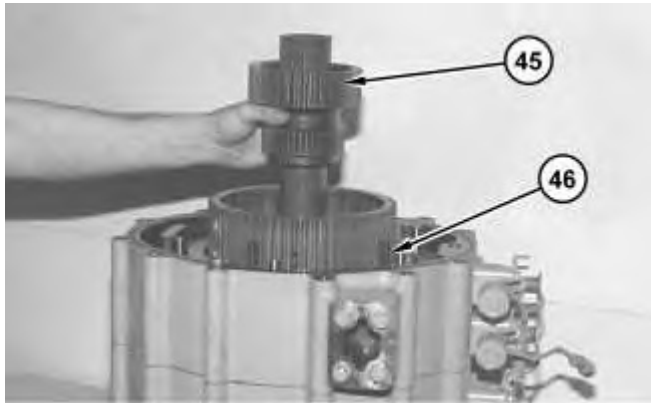

Illustration 27

g03066924

29. Remove sun gear (45) and springs (46) .

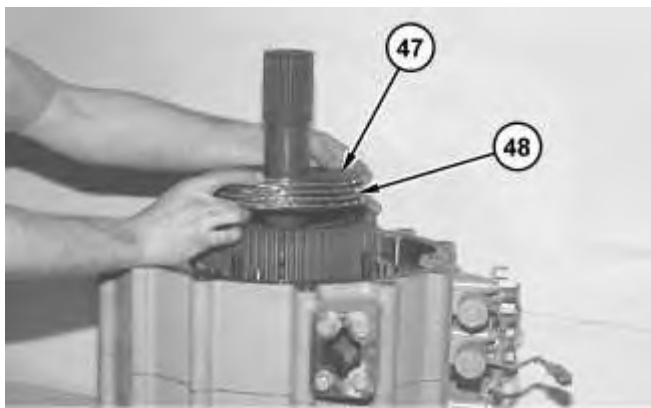

Illustration 28

g03066937

30. Remove friction discs (47) and clutch plates (48) .



31. Remove ring gear (34) .



Illustration 30

32. Remove retaining ring (49) and reaction plate (50) .



Illustration 31

33. Use Tooling (A) and a suitable lifting device to remove housing (51) and the O-ring seal. The weight of housing (51) is approximately 29 kg (64 lb).

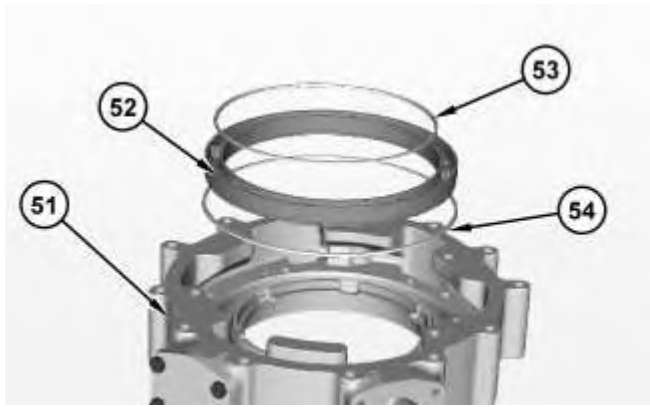

Illustration 32

g03067134

34. Remove clutch piston (52) from housing (51) . Remove seal ring (53) and remove seal ring (54) from clutch piston (52) .

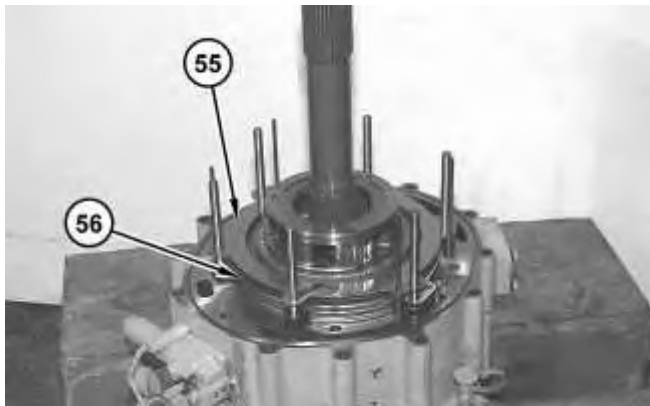

Illustration 33

g03067176

35. Remove friction discs (56) and clutch plates (55) .

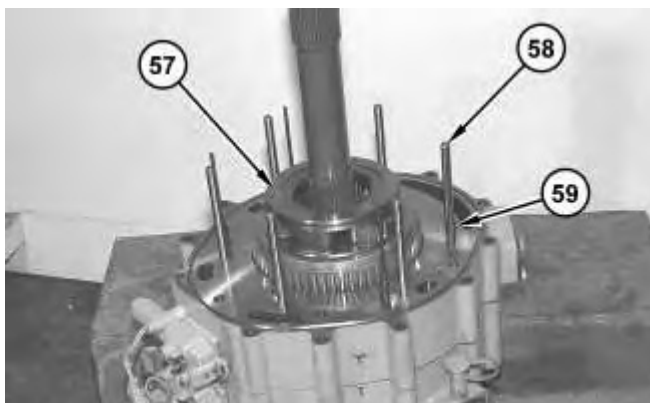

Illustration 34

g03067205

36. Remove reaction dowels (58) , springs (59) , and carrier assembly (57) .

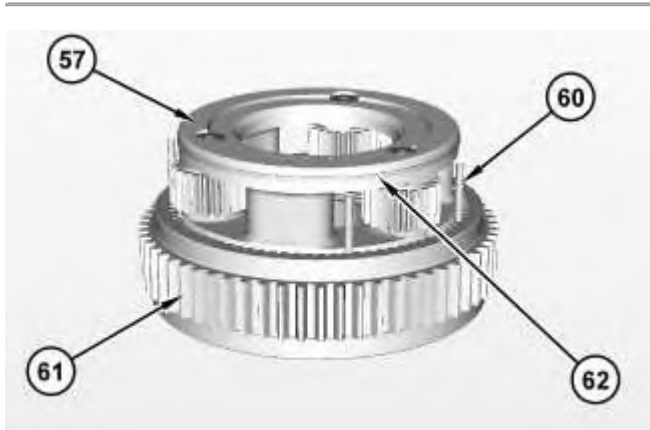

Illustration 35

g03070259

37. Use steel rods (60) (3.175 mm (0.1250 inch)) in order to compress the retaining ring that holds carrier assembly (57) to ring gear (61) .

38. Remove carrier assembly (57) and seal ring (62) from ring gear (61) .

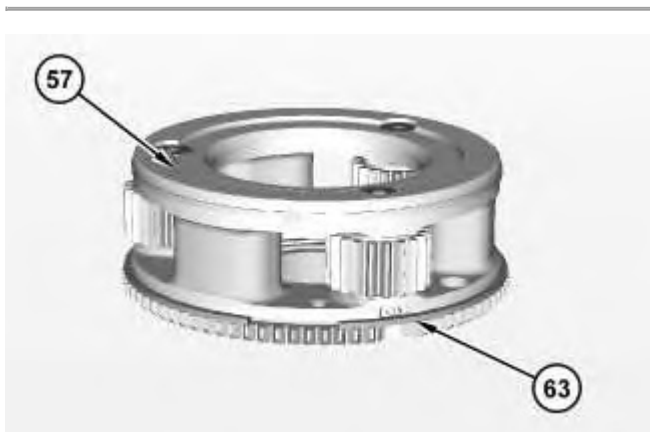

Illustration 36

g03070356

39. Remove retaining ring (63) from carrier assembly (57) .

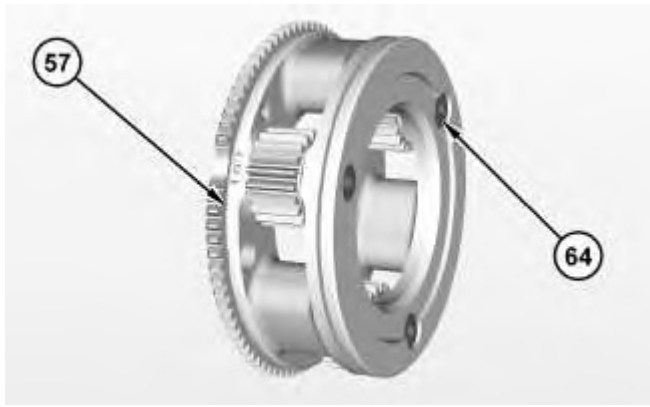

Illustration 37

g03070436

40. Use a hammer and a punch to push the spring pins through carrier assembly (57) and into planetary shafts (64) .
41. Use a suitable hammer and a punch to remove planetary shafts (64) from carrier assembly (58) .

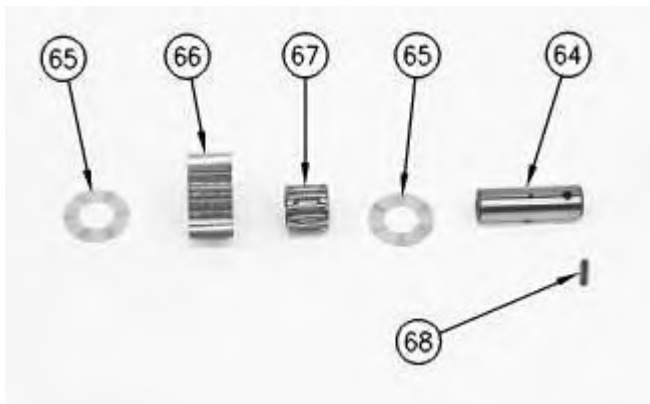

Illustration 38

g00324891

42. Remove thrust discs (65) , planetary gears (66) , and bearings (67) from the carrier assembly. Remove spring pins (68) from planetary shafts (64) .
43. Remove the plastic thrust disc that is between the reverse planetary carrier and the forward planetary carrier.

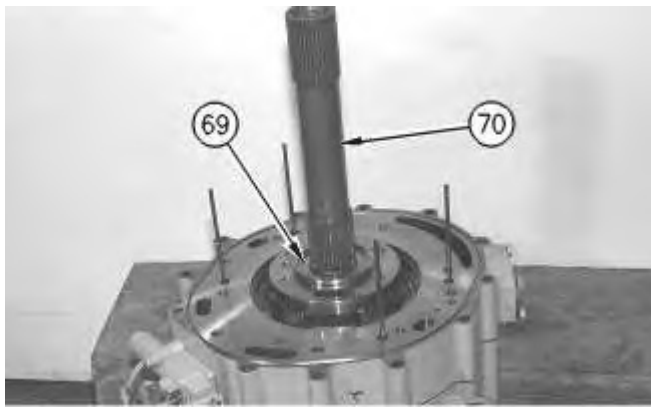

Illustration 39

g00324892

44. Remove retaining ring (69) that holds output shaft (70) to the input shaft.

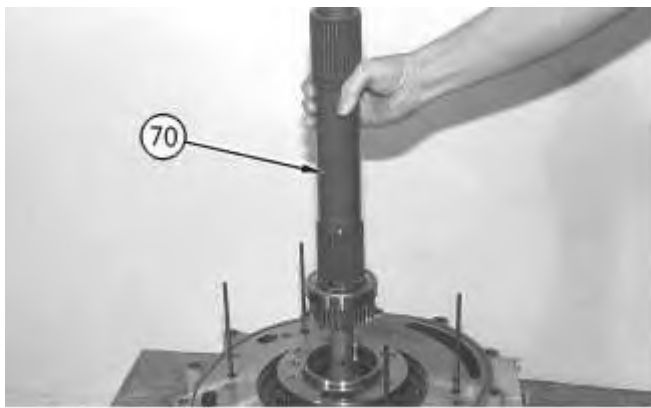

Illustration 40

g00324893

45. Remove output shaft (70) .

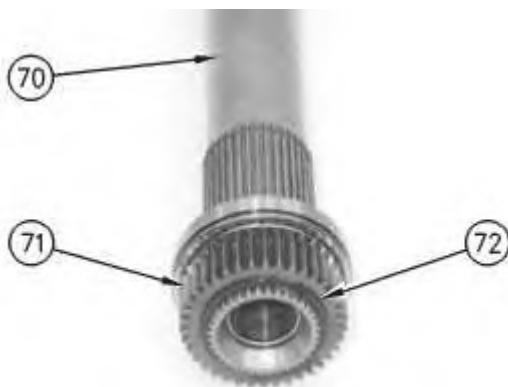

Illustration 41

g00324903

46. Use Tooling (E) to remove retaining ring (72) .

47. Remove sun gear (71) from output shaft (70) .

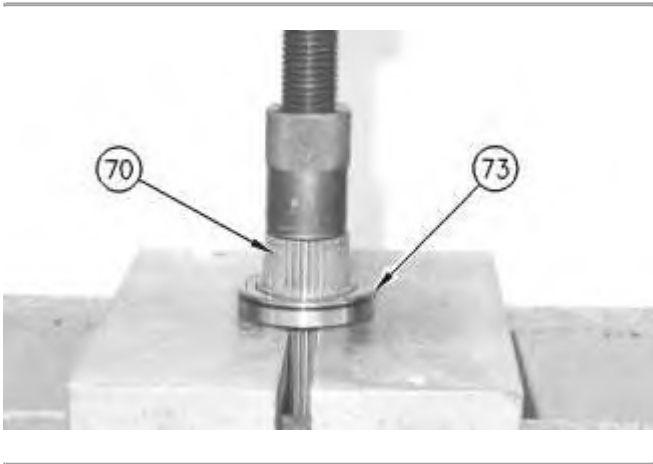

Illustration 42

g00324904

48. Use a suitable press to push output shaft (70) out of bearing (73) , as shown.

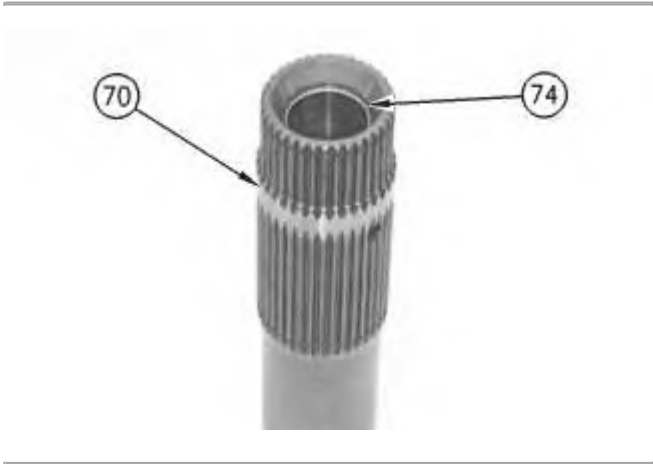
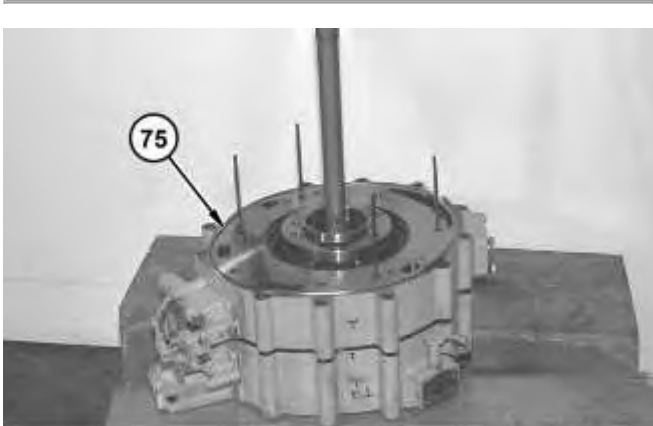

Illustration 43

g00324905

49. If necessary, remove bearings (74) from both ends of output shaft (70) .



50. Use Tooling (A) and a suitable lifting device to remove housing (75) and the O-ring seal. The weight of housing (75) is approximately 29 kg (64 lb).

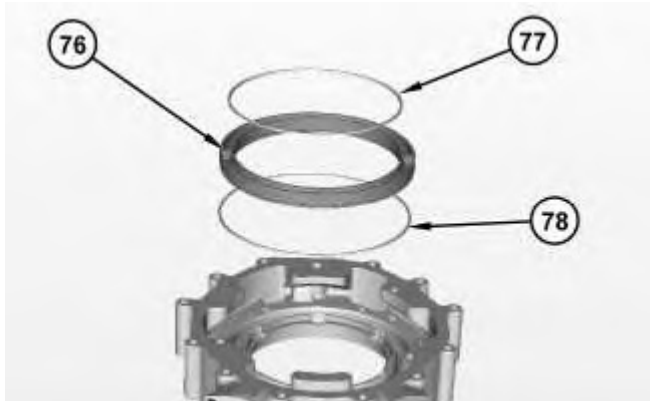

Illustration 45

51. Remove clutch piston (76) , and remove seal rings (77) and (78) from clutch piston (76) .

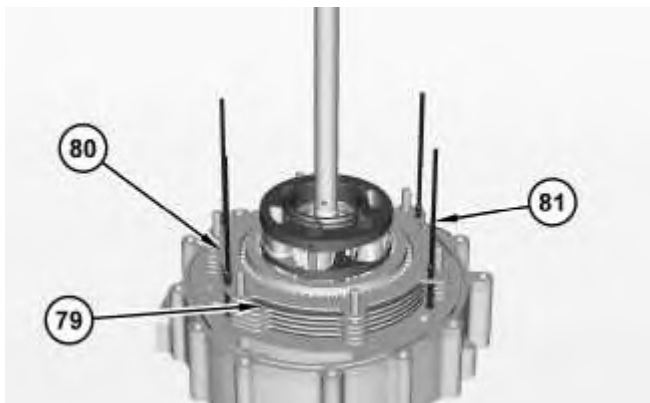

Illustration 46

52. Remove friction discs (79) , and clutch plates (80) and spring rods (81) .
-

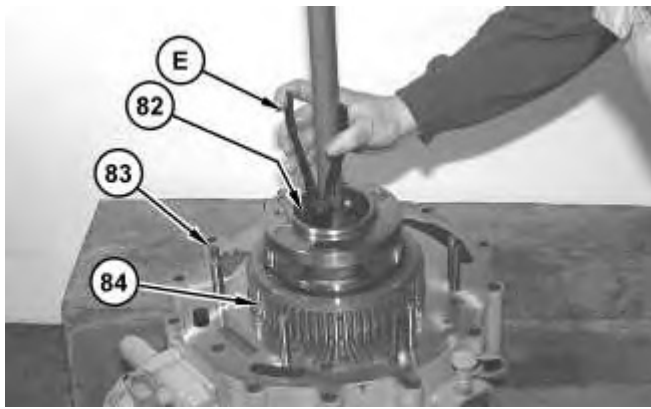

Illustration 47

g01174719

53. Use Tooling (E) to remove retaining ring (82) from the input shaft.

54. Remove springs (83) and ring gear (84) .



Illustration 48

g00324948

55. Remove carrier assembly (85) from the input shaft.



Illustration 49

g00328227

56. Remove plastic thrust disc (123) that is used between the reverse planetary carrier and forward planetary carrier.

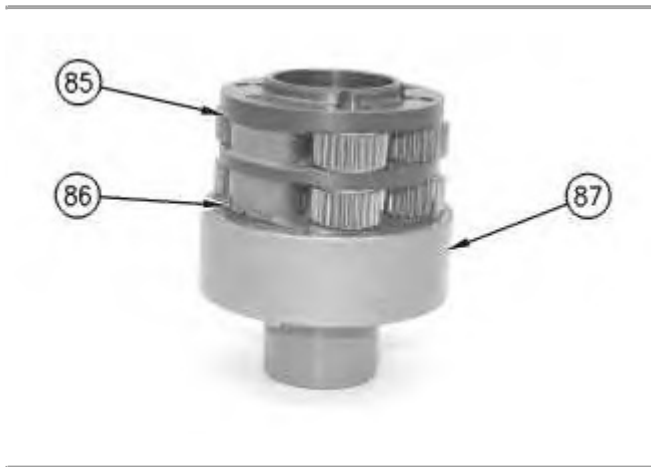

Illustration 50

g00324963

57. Place a small block under carrier assembly (85) .
58. Use rods (86) (2.36 mm (0.093 inch)) in order to compress the retaining ring that holds carrier assembly (85) to ring gear (87) together.
59. Remove ring gear (87) from carrier assembly (85) .

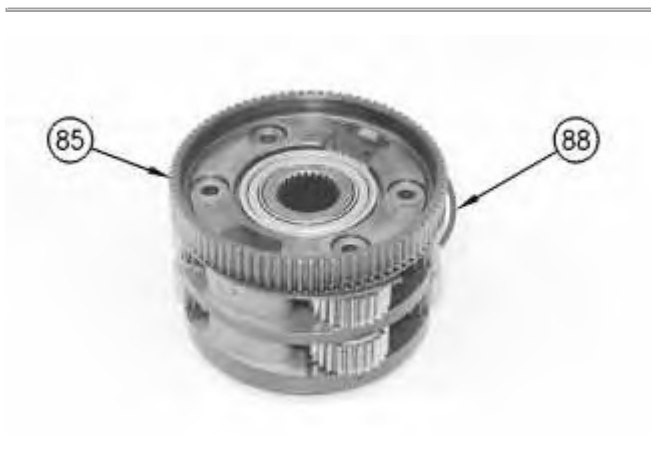

Illustration 51

g00324964

60. Remove retaining ring (88) from carrier assembly (85) .
-

63. Remove thrust discs (91) , bearings (93) , planetary gears (92) , bearings (93) and planetary gears (92) from the carrier assembly.
64. Remove spring pins (90) from planetary shafts (89) .

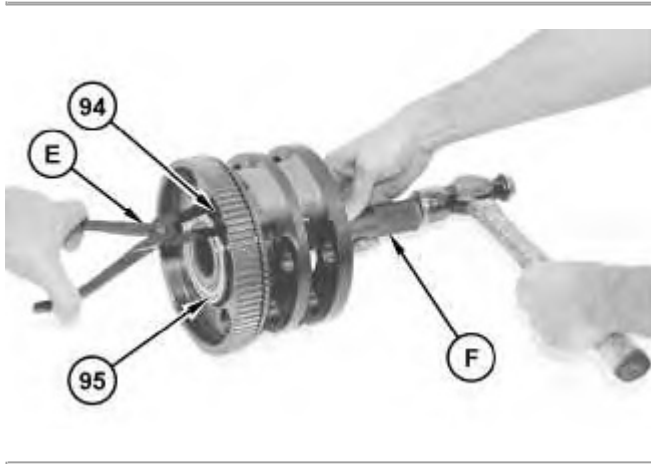

Illustration 55

g01293743

65. Use Tooling (E) to expand retaining ring (94) . Use Tooling (F) to remove bearing (95) and the sun gear as a unit.



Illustration 56

g00324979

66. Use a suitable press to remove bearing (95) from sun gear (96) .
-

Thank you so much for reading.
Please click the “Buy Now!”
button below to download the
complete manual.



After you pay.

You can download the most
perfect and complete manual in
the world immediately.

Our support email:

ebooklibonline@outlook.com