

Product: TRACK LOADER

Model: 963 TRACK LOADER 11Z

Configuration: 963 LGP TRACK LOADER / HIGH DRIVE / 11Z00001-UP (MACHINE) POWERED BY 3304 ENGINE

## Disassembly and Assembly 3304B and 3306B Engines for Caterpillar Built Machines

Media Number -SEN5598-09

Publication Date -01/01/2013

Date Updated -25/01/2013

i02107004

# Gear Group (Front) - Remove

SMCS - 1206-011

## Removal Procedure

Table 1

Required Tools			
Tool	Part Number	Part Description	Qty
A	1P-0510	Driver Group	1

### Start By:

- A. Remove the automatic timing advance unit. Refer to Disassembly and Assembly, "Automatic Timing Advance - Remove".

---

### NOTICE

**Keep all parts clean from contaminants.**

**Contaminants may cause rapid wear and shortened component life.**

---



Illustration 1

g00476414

1. Remove bolts (1), plate (2), and fuel pump idler gear (3) .

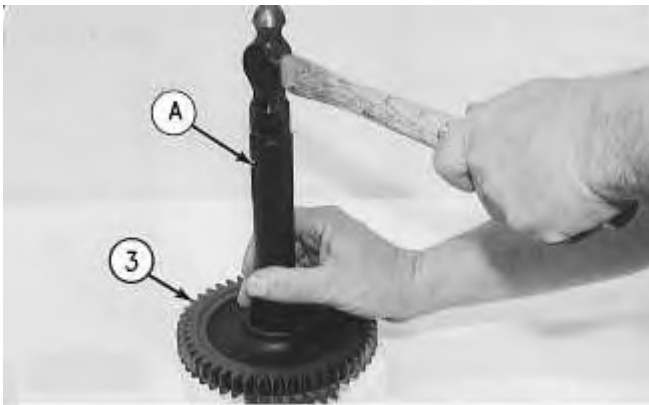

Illustration 2

g00476416

2. Remove the bearing from fuel pump idler gear (3) with Tooling (A) .

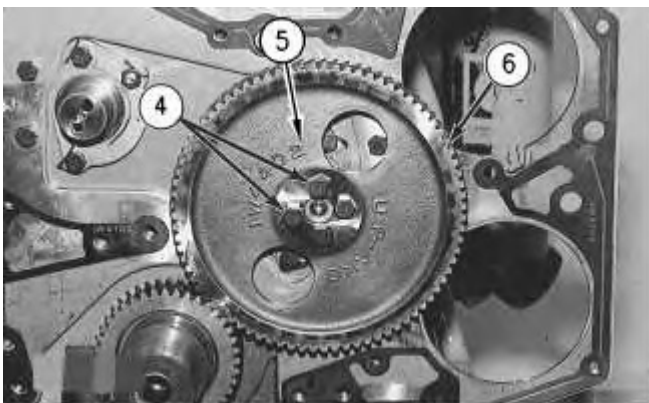

Illustration 3

g00476417

3. Remove bolts (4), plate (5), and camshaft gear (6) .

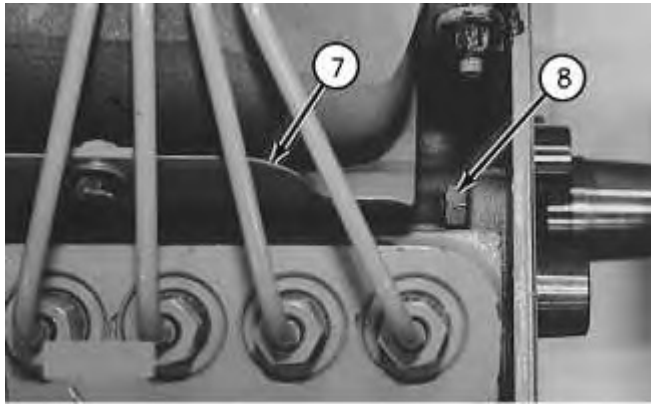

Illustration 4

g00476418

4. Remove the bolts that hold shield (7) in position between the fuel pump and the exhaust manifold. Slide the shield backward from the timing cover plate.
5. Remove nuts (8) .

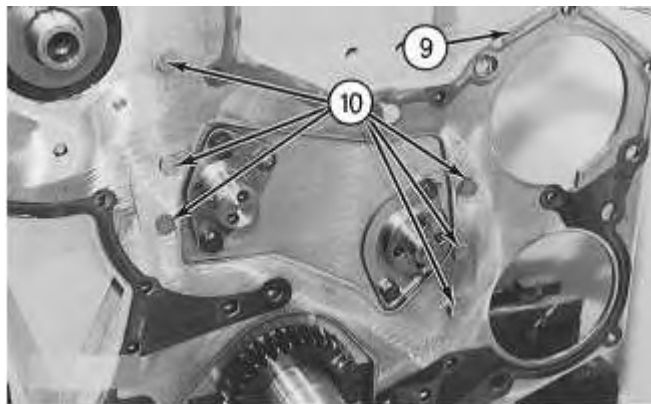

Illustration 5

g00476419

6. Remove bolts (10). Remove timing gear plate (9) and the gasket.
-

Product: TRACK LOADER

Model: 963 TRACK LOADER 11Z

Configuration: 963 LGP TRACK LOADER / HIGH DRIVE / 11Z00001-UP (MACHINE) POWERED BY 3304 ENGINE

## Disassembly and Assembly 3304B and 3306B Engines for Caterpillar Built Machines

Media Number -SEN5598-09

Publication Date -01/01/2013

Date Updated -25/01/2013

i02107019

# Gear Group (Front) - Install

SMCS - 1206-012

## Installation Procedure

Table 1

Required Tools			
Tool	Part Number	Part Description	Qty
A	1P-0510	Driver Group	1
B	9S-3263	Thread Lock Compound	1

---

### NOTICE

**Keep all parts clean from contaminants.**

**Contaminants may cause rapid wear and shortened component life.**

---

**Note:** Check the condition of the gaskets and the O-ring seals. If the gaskets or the O-ring seals are worn or damaged, use new parts for replacement.

1. Clean the old gasket from the contact surfaces of the timing gear plate and the cylinder block. Install a new gasket on the cylinder block. Cut the gasket even with the bottom face of the cylinder block.
-

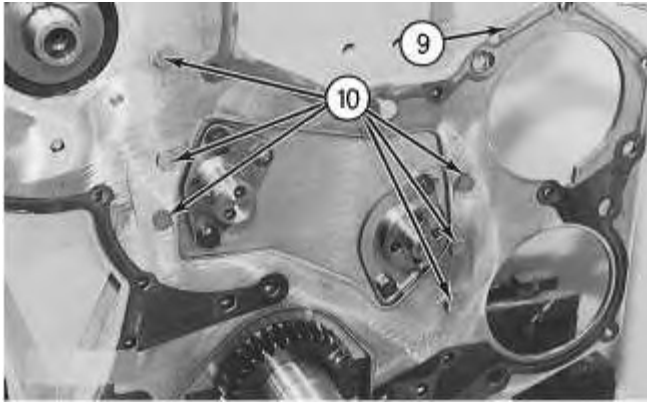

Illustration 1

g00476419

---

## NOTICE

**The bolts that hold the timing gear plate in position on the cylinder block should have a reduced bolt head thickness. The reduced bolt head thickness is needed for clearance for the gears.**

---

2. Ensure that the O-ring seals are in position on the end of the fuel injection pump housing. Put timing gear plate (9) in position on the cylinder block. Install bolts (10) .

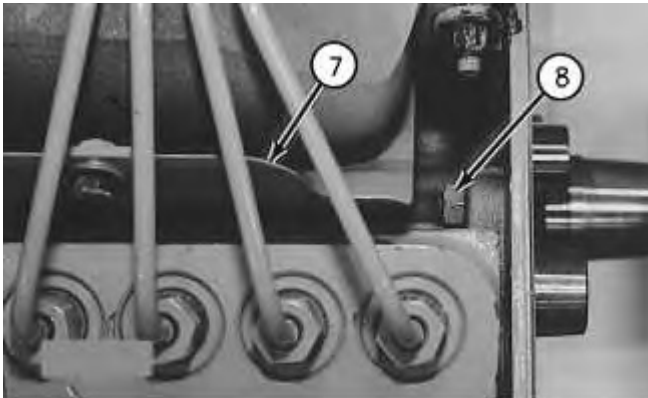

Illustration 2

g00476418

3. Install shield (7). Install nuts (8) .

**Note:** After the timing gear plate is installed, ensure that the rack is free to move in the fuel injection pump housing. The O-ring seal on the drive end of the fuel injection pump housing can hold the rack. This can help prevent free rack movement. Rack movement can be seen through a hole in the timing gear plate just above the mounting of the fuel pump gear. If the rack does not move freely, remove the timing gear plate and check the O-ring seal on the drive end of the fuel injection pump housing.

## **WARNING**

**If the rack does not move freely, the engine can over speed and be damaged. Serious personal injury may result.**

---

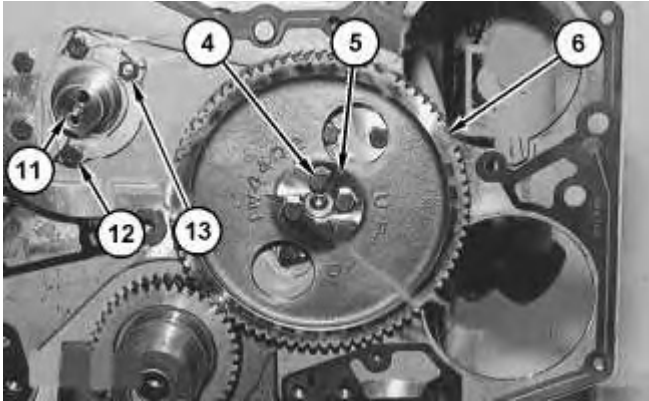

Illustration 3

g01072912

**Note:** If idler gear shaft (11) for the fuel pump idler gear was removed, use Tooling (B) on the threads of bolts (12) and nut (13) before reinstalling idler gear shaft (11). Tighten bolts (12) and nut (13) to a torque of  $50 \pm 10$  N·m ( $37 \pm 7$  lb ft).

- Put camshaft gear (6) and plate (5) in position on the engine. Align the Mark "C" on the camshaft gear with the Mark "C" on the crankshaft gear. Install bolts (4) and tighten bolts (4) to a torque of  $55 \pm 7$  N·m ( $41 \pm 5$  lb ft).

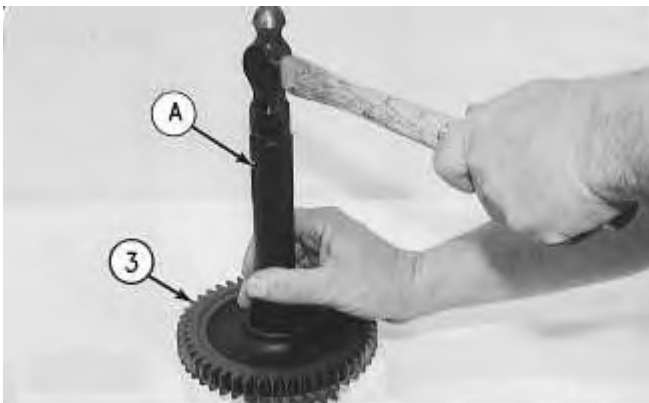

Illustration 4

g00476416

- Use Tooling (A) in order to install the bearing in fuel pump idler gear (3). The end of the bearing must be  $3.00 \pm 0.25$  mm ( $.118 \pm .010$  inch) below the face of the hub of the fuel pump idler gear.

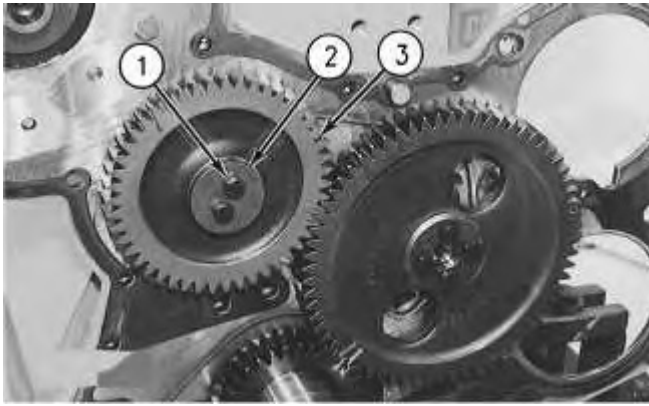

Illustration 5

g00476414

6. Ensure that the oil hole in the shaft for fuel pump idler gear (3) is open. Install fuel pump idler gear (3). Put plate (2) in position with the finished side facing toward fuel pump idler gear (3). Apply Tooling (B) on bolts (1). Install bolts (1) that hold fuel pump idler gear (3) in position.

**Note:** Remove excess Tooling (B) on plate (2). Excess Tooling (B) on plate (2) may flow into the gear bearings. This condition can affect lubrication. Bearing life can also be affected.

**End By:** Install the automatic timing advance unit. Refer to Disassembly and Assembly, "Automatic Timing Advance - Install".

---

Product: TRACK LOADER

Model: 963 TRACK LOADER 11Z

Configuration: 963 LGP TRACK LOADER / HIGH DRIVE / 11Z00001-UP (MACHINE) POWERED BY 3304 ENGINE

## **Disassembly and Assembly 3304B and 3306B Engines for Caterpillar Built Machines**

Media Number -SEN5598-09

Publication Date -01/01/2013

Date Updated -25/01/2013

i02107163

# **Housing (Front) - Remove**

SMCS - 1151-011

## **Removal Procedure**

### **Start By:**

- A. Remove the water pump. Refer to Disassembly and Assembly, "Water Pump - Remove".
- B. Remove the crankshaft front seal. Refer to Disassembly and Assembly, "Crankshaft Front Seal - Remove".

---

### **NOTICE**

**Keep all parts clean from contaminants.**

**Contaminants may cause rapid wear and shortened component life.**

---

---

### **NOTICE**

**Care must be taken to ensure that fluids are contained during performance of inspection, maintenance, testing, adjusting and repair of the product. Be prepared to collect the fluid with suitable containers before opening any compartment or disassembling any component containing fluids.**

**Refer to Special Publication, NENG2500, "Caterpillar Tools and Shop Products Guide" for tools and supplies suitable to collect and contain fluids on Caterpillar products.**

**Dispose of all fluids according to local regulations and mandates.**



- 
1. Remove the bolts that hold the oil pan and the oil pan plate to the front housing. Loosen the remaining bolts that hold the oil pan in position. Put spacers between the cylinder block and the oil pan plate. This must be done in order to prevent damage to the gasket for the oil pan plate.

**Note:** If the gasket for the oil pan plate is damaged, the oil pan plate must be removed. Refer to Disassembly and Assembly, "Engine Oil Pan Plate - Remove and Install".

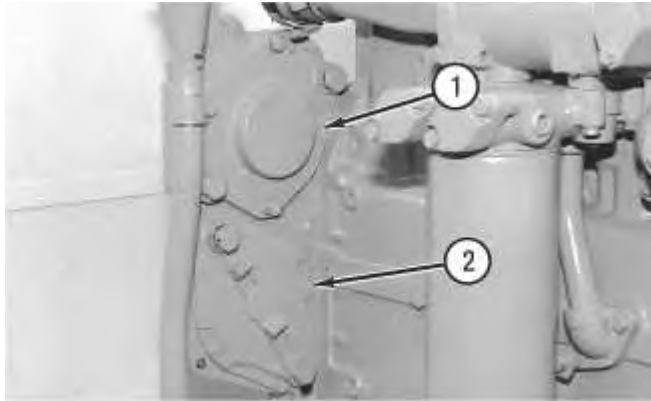

Illustration 1

g00512114

2. Remove covers (1) and (2) from the back of the front plate.

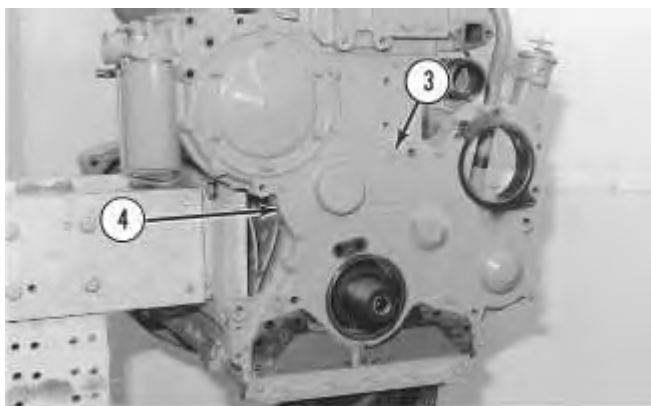

Illustration 2

g00512122

3. Remove all bolts (3) that hold front housing (4) in position on the engine. Remove front housing (4) and the gasket from the engine.
-

Product: TRACK LOADER

Model: 963 TRACK LOADER 11Z

Configuration: 963 LGP TRACK LOADER / HIGH DRIVE / 11Z00001-UP (MACHINE) POWERED BY 3304 ENGINE

## Disassembly and Assembly 3304B and 3306B Engines for Caterpillar Built Machines

Media Number -SEN5598-09

Publication Date -01/01/2013

Date Updated -25/01/2013

i02107191

## Housing (Front) - Install

SMCS - 1151-012

## Installation Procedure

Table 1

Required Tools			
Tool	Part Number	Part Description	Qty
A	3S-6252	Sealant	1

---

### NOTICE

**Keep all parts clean from contaminants.**

**Contaminants may cause rapid wear and shortened component life.**

---

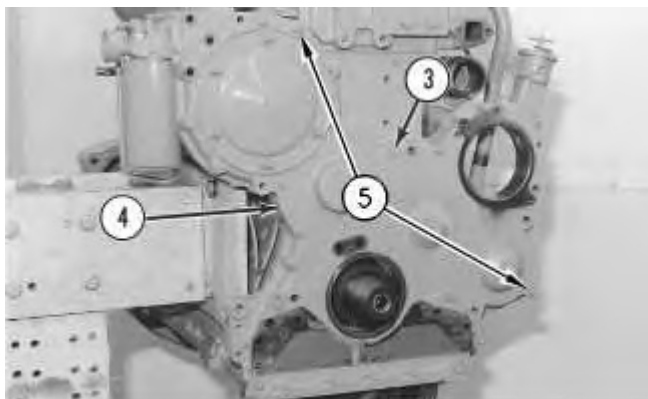

1. Put the gasket and front housing (4) in position on the engine. Install all bolts (3) that hold the front housing to the engine. Tighten bolts (5) to a torque of  $23 \pm 4$  N·m ( $17 \pm 3$  lb ft).

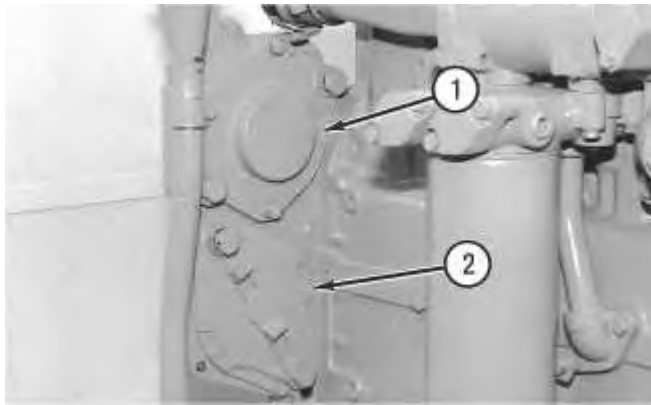

Illustration 2

2. Put the gasket and cover (1) in position and install the bolts that fasten cover (1) to the front plate. Put the O-ring seal and cover (2) in position and install the bolts that fasten cover (2) to the front plate.
3. Trim the front housing gasket so the gasket is even with the bottom of the cylinder block.  
**Note:** If the oil pan plate was removed, install a new gasket and install the oil pan plate. Refer to Disassembly and Assembly, "Engine Oil Pan Plate - Remove and Install".
4. Apply Tooling (A) to the bottom surface of the front housing gasket. Remove the spacers that were installed between the cylinder block and the oil pan plate. Install the bolts that hold the oil pan and the oil pan plate to the front housing. Tighten the remaining bolts that hold the oil pan in position.

Product: TRACK LOADER

Model: 963 TRACK LOADER 11Z

Configuration: 963 LGP TRACK LOADER / HIGH DRIVE / 11Z00001-UP (MACHINE) POWERED BY 3304 ENGINE

## Disassembly and Assembly 3304B and 3306B Engines for Caterpillar Built Machines

Media Number -SEN5598-09

Publication Date -01/01/2013

Date Updated -25/01/2013

i04880697

# Valve Mechanism Cover - Remove and Install

SMCS - 1107-010

## 3304B Removal Procedure

---

### NOTICE

**Keep all parts clean from contaminants.**

**Contaminants may cause rapid wear and shortened component life.**

---

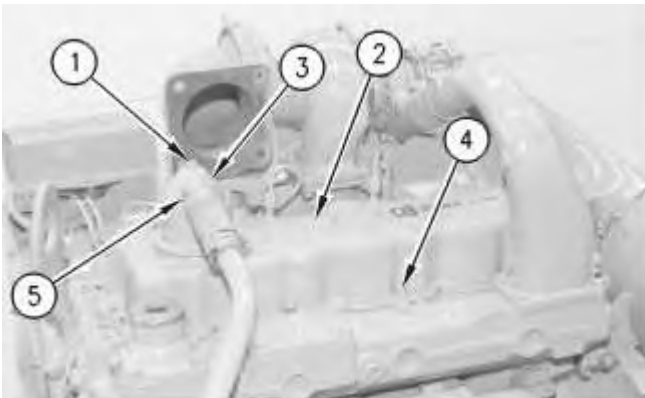

Illustration 1

g00590318

1. Loosen hose clamp (5) and remove the hose from breather cap (3) .
2. Remove bolt (1) and remove breather cap (3) .

3. Remove bolts (4) and the washers that hold valve mechanism cover (2) in position. Remove valve mechanism cover (2) and the gasket.

## 3306B Removal Procedure

---

### NOTICE

**Keep all parts clean from contaminants.**

**Contaminants may cause rapid wear and shortened component life.**

---

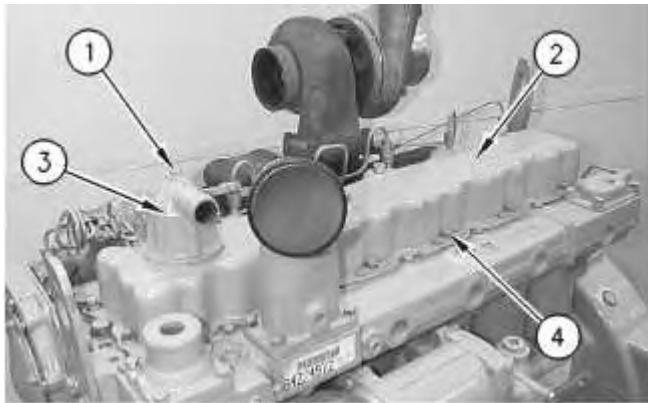

Illustration 2

g00513507

1. Remove bolt (1) and breather cap (3) from valve mechanism cover (2) . Remove the O-ring seal from breather cap (3) .
2. Remove bolts (4) and the washers that hold valve mechanism cover (2) in position. Remove valve mechanism cover (2) and the gasket.

## 3304B Installation Procedure

---

### NOTICE

**Keep all parts clean from contaminants.**

**Contaminants may cause rapid wear and shortened component life.**

---

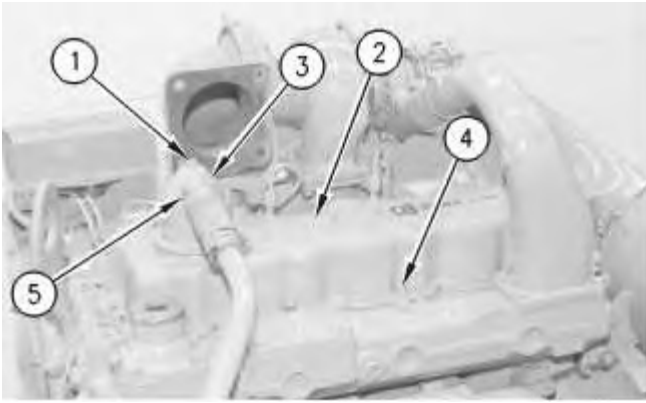

Illustration 3

g00590318

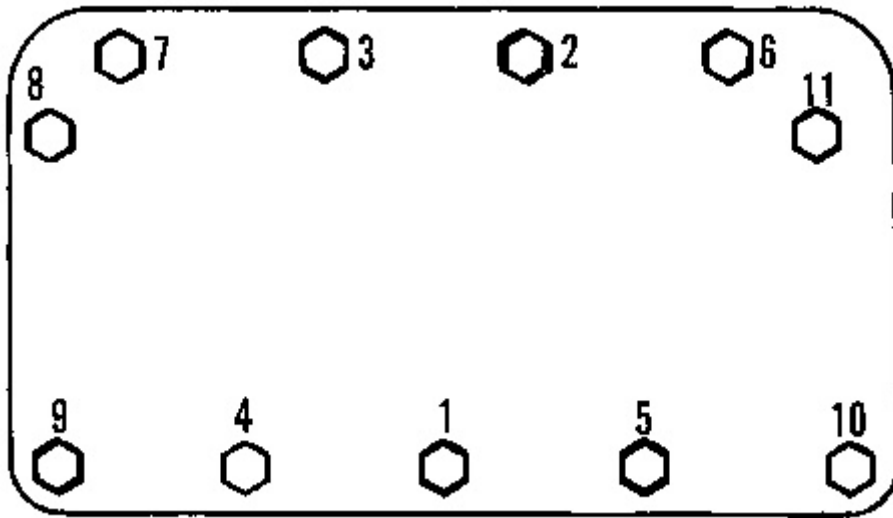

Illustration 4

g00590290

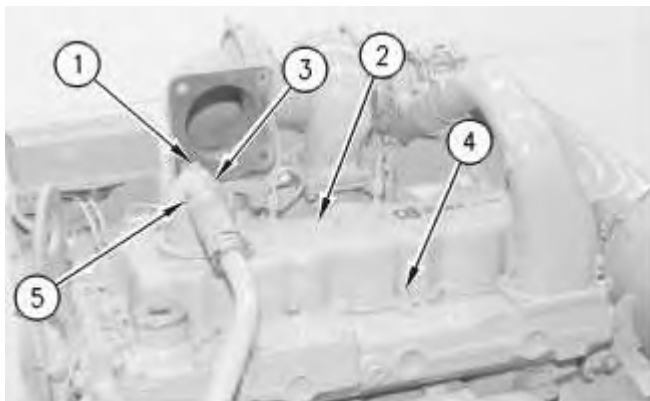

Illustration 5

g00590318

**Note:** Check the condition of the gasket. If the gasket is worn or damaged, use new parts for replacement.

1. Install a new gasket for valve mechanism cover (2) . Apply **5H-2471** Adhesive on the surfaces of the gasket and valve mechanism cover (2) . Place valve mechanism cover (2) in position on the cylinder head.
2. Install bolts (4) that hold valve mechanism cover (2) . Tighten the bolts in a numerical sequence to a torque of  $16 \pm 3$  N·m ( $12 \pm 2$  lb ft).
3. Install the hose on breather cap (3) and tighten hose clamp (5) .

## 3306B Installation Procedure

---

### NOTICE

**Keep all parts clean from contaminants.**

**Contaminants may cause rapid wear and shortened component life.**

---

**Note:** Check the condition of the gasket and O-ring seals. If the gasket or the O-ring seals are worn or damaged, use new parts for replacement.

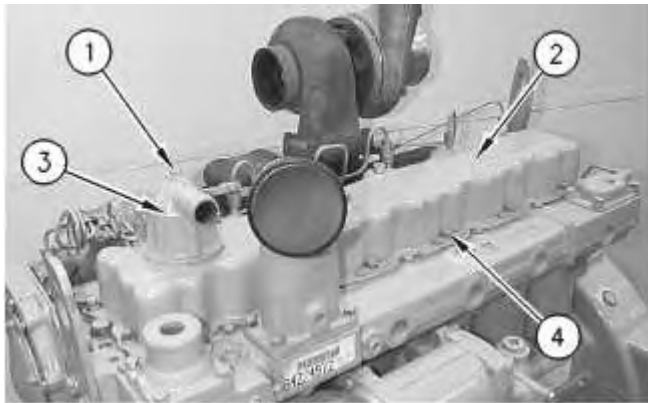
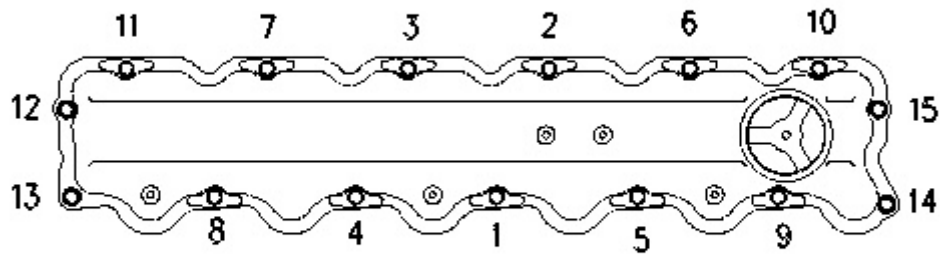

Illustration 6

g00513507

1. Install a new gasket for valve mechanism cover (2) . Put valve mechanism cover (2) in position on the cylinder head.
-



---

Illustration 7

g00450791

2. Install the washers and bolts (4) that hold valve mechanism cover (2) in position. Tighten the bolts in a numerical sequence to a torque of  $16 \pm 3 \text{ N}\cdot\text{m}$  ( $12 \pm 2 \text{ lb ft}$ ). Use the numerical sequence that is shown in illustration 7.
  3. Put the O-ring seal and breather cap (3) in position. Install the washer and bolt (1) . Tighten bolt (1) to a torque of  $14 \pm 3 \text{ N}\cdot\text{m}$  ( $10 \pm 2 \text{ lb ft}$ ).
-



Product: TRACK LOADER

Model: 963 TRACK LOADER 11Z

Configuration: 963 LGP TRACK LOADER / HIGH DRIVE / 11Z00001-UP (MACHINE) POWERED BY 3304 ENGINE

## Disassembly and Assembly 3304B and 3306B Engines for Caterpillar Built Machines

Media Number -SEN5598-09

Publication Date -01/01/2013

Date Updated -25/01/2013

i00921540

# Compression Brake - Remove

SMCS - 1119-011

## Removal Procedure

### Start By:

- A. Remove the valve mechanism cover. Refer to Disassembly and Assembly, "Valve Mechanism Cover - Remove and Install".

---

### NOTICE

**Keep all parts clean from contaminants.**

**Contaminants may cause rapid wear and shortened component life.**

---

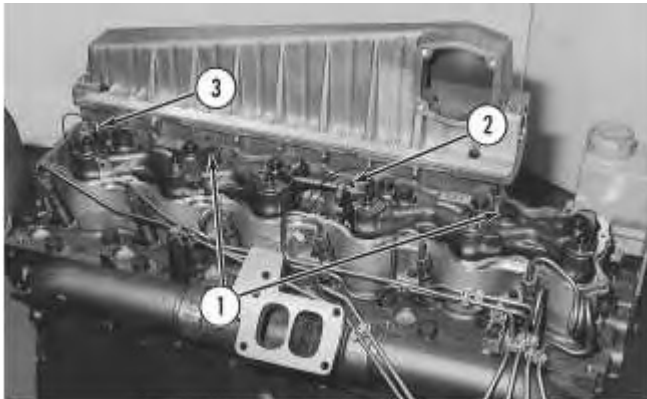

Illustration 1

g00471009

1. Remove four bolts (1). Disconnect wires (2) and (3) .

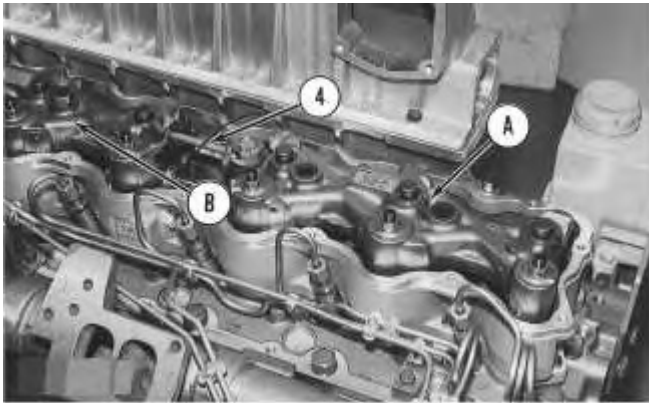

Illustration 2

g00471010

2. Remove Compression Brake (A) by lifting Compression Brake (A) with one hand. Remove Compression Brake (A) while you hold oil tube (4) in order to ensure that oil tube (4) does not come out of Compression Brake (B) .
  3. Remove Compression Brake (B) .
-

Product: TRACK LOADER

Model: 963 TRACK LOADER 11Z

Configuration: 963 LGP TRACK LOADER / HIGH DRIVE / 11Z00001-UP (MACHINE) POWERED BY 3304 ENGINE

## Disassembly and Assembly 3304B and 3306B Engines for Caterpillar Built Machines

Media Number -SEN5598-09

Publication Date -01/01/2013

Date Updated -25/01/2013

i00921740

# Compression Brake - Disassemble

SMCS - 1119-015

## Disassembly Procedure

### Start By:

- A. Remove the Compression Brake. Refer to Disassembly and Assembly, "Compression Brake - Remove".

---

### NOTICE

**Keep all parts clean from contaminants.**

**Contaminants may cause rapid wear and shortened component life.**

---

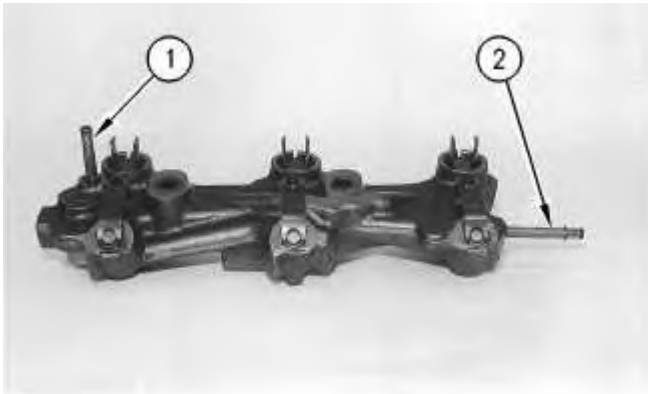

Illustration 1

g00471083

1. Remove oil tubes (1) and (2). Remove the O-ring seals.

**Note:** If the O-ring seals are worn or damaged, use new parts for replacement.

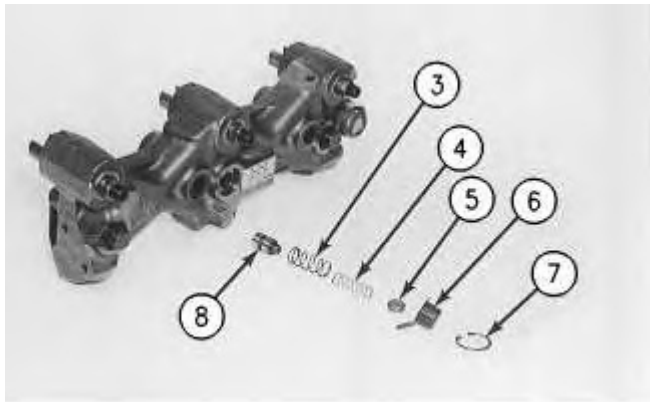

Illustration 2

g00471084

2. Remove snap ring (7), cup (6), spacer (5), springs (4) and (3) and piston (8) .

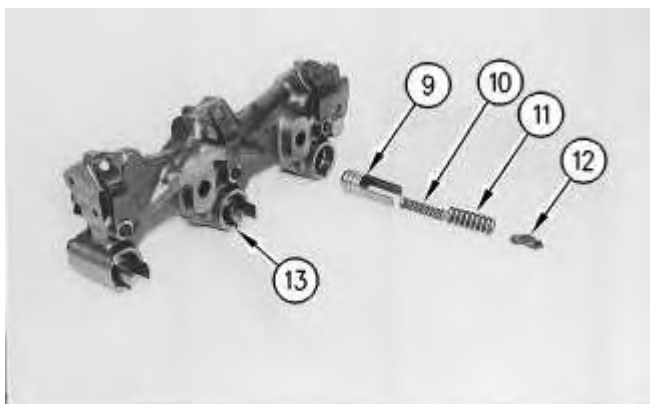
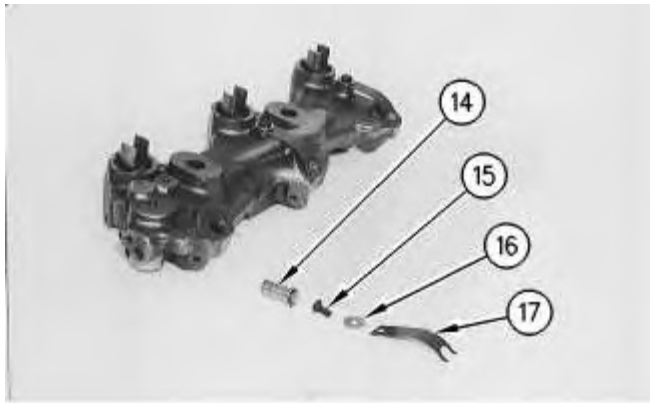

Illustration 3

g00471085

3. Remove three retaining rings (13). Remove clip (12), springs (11) and (10) and piston (9) from three locations on the Compression Brake.
-



---

Illustration 4

g00471086

4. Remove three bolts (15), washers (16), clips (17) and piston (14) .
-

Product: TRACK LOADER

Model: 963 TRACK LOADER 11Z

Configuration: 963 LGP TRACK LOADER / HIGH DRIVE / 11Z00001-UP (MACHINE) POWERED BY 3304 ENGINE

## Disassembly and Assembly 3304B and 3306B Engines for Caterpillar Built Machines

Media Number -SEN5598-09

Publication Date -01/01/2013

Date Updated -25/01/2013

i00921835

# Compression Brake - Assemble

SMCS - 1119-016

## Assembly Procedure

---

### NOTICE

**Keep all parts clean from contaminants.**

**Contaminants may cause rapid wear and shortened component life.**

---

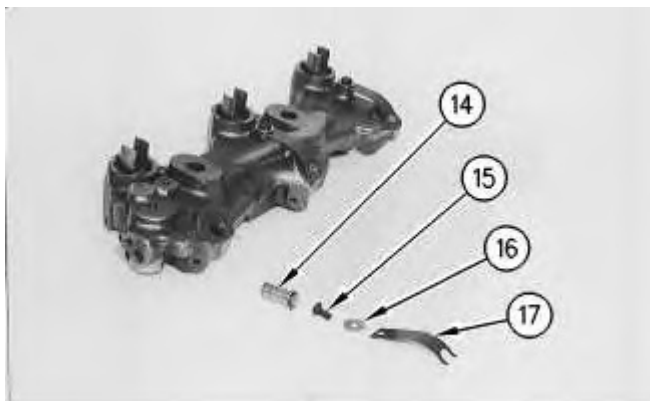

Illustration 1

g00471086

1. Install piston (14), clips (17), washers (16) and three bolts (15).
-

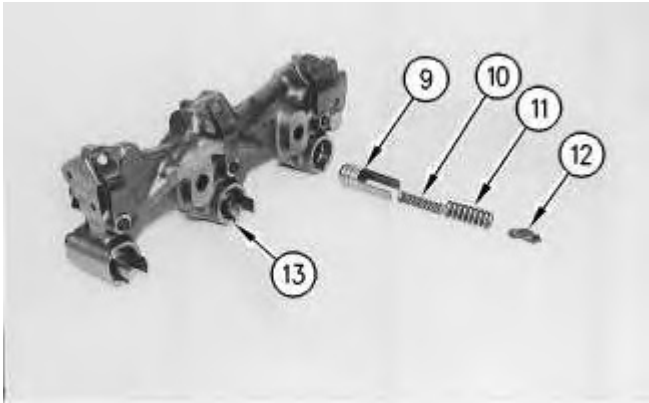

Illustration 2

g00471085

2. Install piston (9), springs (10) and (11) and clip (12) on three locations on the Compression Brake. Install three retaining rings (13) .

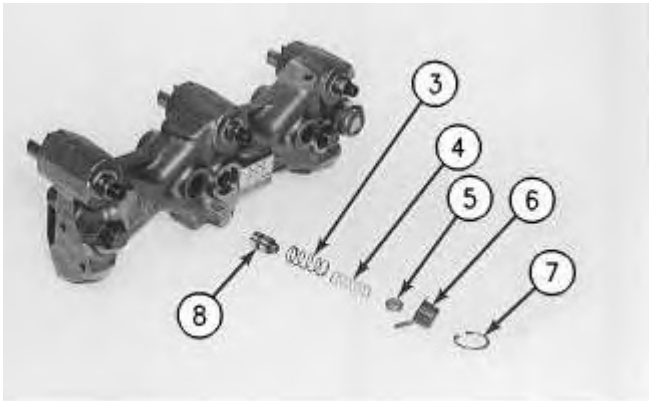

Illustration 3

g00471084

3. Install piston (8), springs (3) and (4), spacer (5), cup (6) and snap ring (7) .

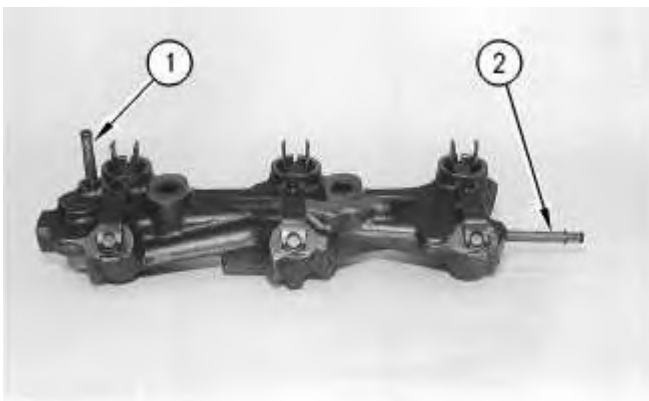

Illustration 4

g00471083

**Note:** If the O-ring seals are worn or damaged, use new parts for replacement.

4. Install the O-ring seals. Install oil tubes (1) and (2) .

**End By:** Install the Compression Brake. Refer to Disassembly and Assembly, "Compression Brake - Install".

---



Model: 963 TRACK LOADER 11Z

Configuration: 963 LGP TRACK LOADER / HIGH DRIVE / 11Z00001-UP (MACHINE) POWERED BY 3304 ENGINE

## **Disassembly and Assembly 3304B and 3306B Engines for Caterpillar Built Machines**

Media Number -SEN5598-09

Publication Date -01/01/2013

Date Updated -25/01/2013

i00921612

# **Compression Brake - Install**

SMCS - 1119-012

## **Installation Procedure**

---

### **NOTICE**

**Keep all parts clean from contaminants.**

**Contaminants may cause rapid wear and shortened component life.**

---

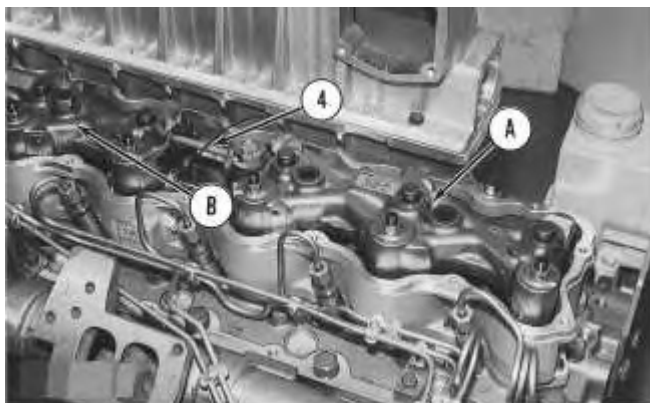

Illustration 1

g00471010

1. Install Compression Brake (B) and oil tube (4) .
2. Install Compression Brake (A) .

Thank you so much for reading.  
Please click the “Buy Now!”  
button below to download the  
complete manual.



After you pay.

You can download the most  
perfect and complete manual in  
the world immediately.

Our support email:

[ebooklibonline@outlook.com](mailto:ebooklibonline@outlook.com)