

Product: TRACK LOADER

Model: 977K TRACK LOADER 48J

Configuration: 977L TRAXCAVATOR 48J02011-UP (MACHINE) POWERED BY 3306 ENGINE

Disassembly and Assembly 3306 VEHICULAR ENGINE FOR 977L TRACK-TYPE LOADER

Media Number -SEN7773-00

Publication Date -01/03/1978

Date Updated -12/10/2001

Fuel Injection Pump Housing

SMCS - 1253-15; 1253-16

Disassemble Fuel Injection Pump Housing

start by:

- a) separation of governor from fuel injection pump housing
- b) remove fuel transfer pump
- c) remove fuel injection pumps

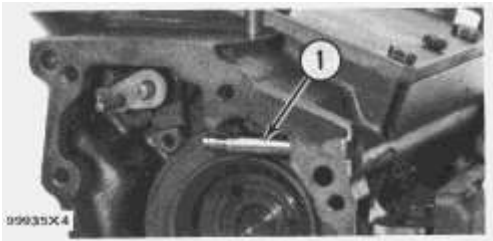

1. Remove dowel (1) from the housing.

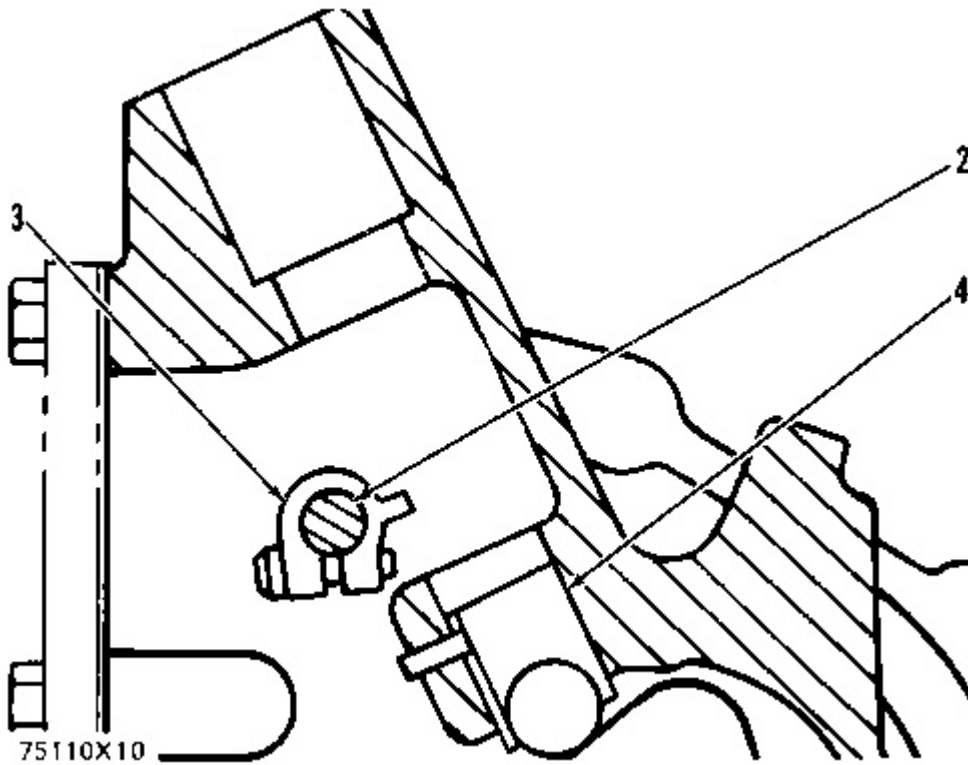

2. Loosen the screws that hold levers (3) to sleeve control shaft (2).
3. Remove sleeve control shaft (2) from the housing.
4. Remove lifter and roller assemblies (4).

NOTE: Put identification numbers on the lifter and roller assemblies. Identification numbers are necessary for correct installation of the lifters and rollers.

5. Remove the camshaft from the housing.

Assemble Fuel Injection Pump Housing

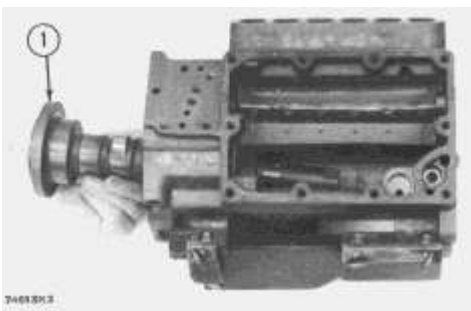

1. Install camshaft (1) in the housing.

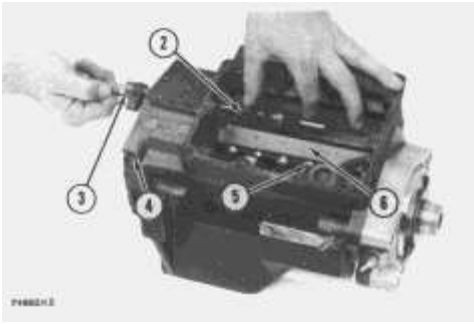

2. Install lifters and roller assemblies (5) in their respective bores.

NOTE: Install the lifters with the grooves of the lifters in alignment with pins (6).

3. Put sleeve control shaft (3) in the housing. Slide levers (2) on the shaft. Push the shaft in the correct position.

4. Install dowel (4) in the housing.

end by:

a) install fuel transfer pump

b) connection of governor to fuel injection pump housing

c) make adjustment to the sleeve control shaft (See Testing and Adjusting for correct procedure)

d) install fuel injection pumps

Product: TRACK LOADER

Model: 977K TRACK LOADER 48J

Configuration: 977L TRAXCAVATOR 48J02011-UP (MACHINE) POWERED BY 3306 ENGINE

Disassembly and Assembly 3306 VEHICULAR ENGINE FOR 977L TRACK-TYPE LOADER

Media Number -SEN7773-00

Publication Date -01/03/1978

Date Updated -12/10/2001

Governor

SMCS - 1264-15; 1264-16

Disassemble Governor

start by:

a) separation of governor from fuel injection pump housing

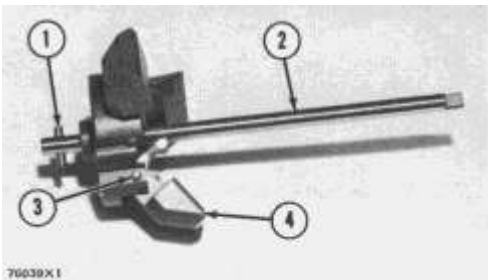

1. Remove shaft (2). Remove pin (1) from shaft.
2. Remove pins (3) from the flyweights. Remove flyweights (4).

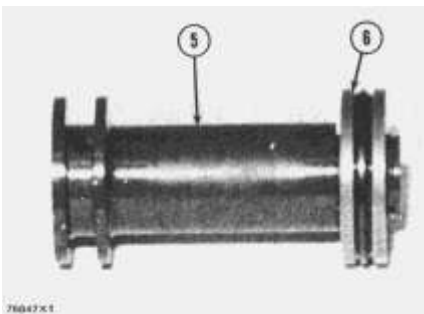

3. Remove ring, races (6) and bearing from the riser (follower) (5).

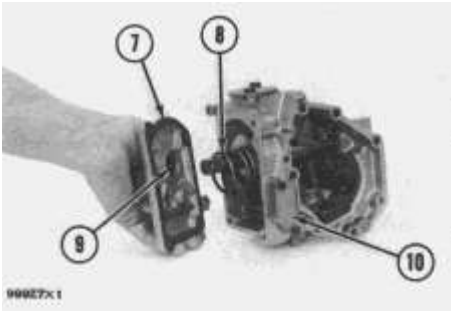

4. Remove cover (7) and spring (8) from governor housing.

NOTE: There is force on the cover from the spring.

5. Remove seal (9) from cover.

6. Remove cover (10) for the low and high idle adjustment.

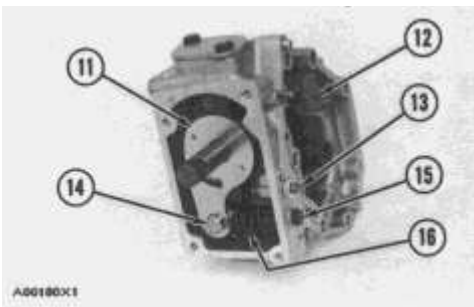

7. Remove locknut and screw (13) for the high idle adjustment.

8. Remove bolt (15) and washers for the low idle adjustment.

9. Remove spring (16) and guide.

10. Remove pin (14) and plate (11).

11. Remove shaft (12) from the housing.

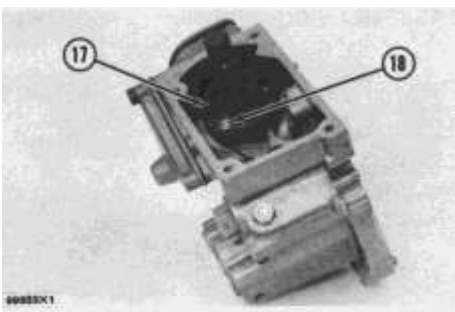

12. Remove pin (18) and two spacers (17) from shaft.

NOTE: Earlier fuel systems have a ball in place of spacers (17) and pin (18).

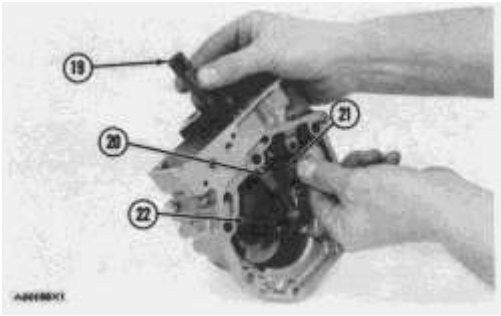

13. Remove shaft (19) from the governor housing.

14. Remove washer (20) and levers (21) and (22) from governor housing.

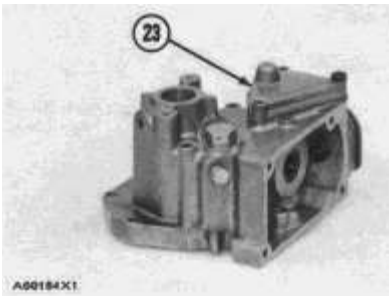

15. Remove cover (23) from governor housing.

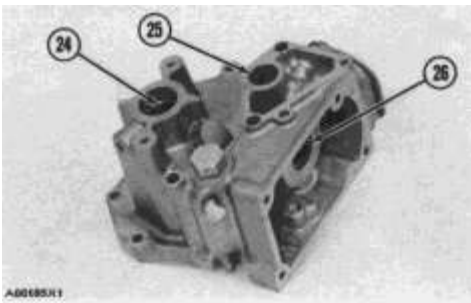

16. Remove seal (25) and bearing.

17. Remove seals (24) and (26) from governor housing.

Assemble Governor

Tools Needed		A	B
1P529	Handle	1	1
1P457	Drive Plate		1
1P471	Drive Plate		1

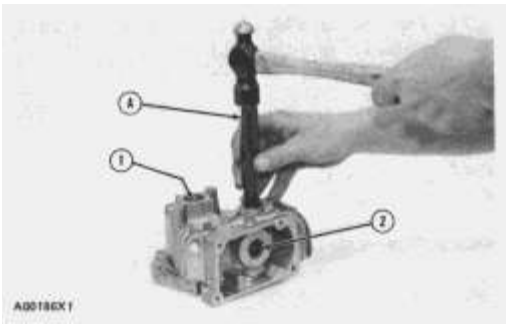

1. Install bearing and seal in the housing with tool (A). The lip of the seal must be toward the bearing.
2. Install seal (1) in housing with tool (A). The lip of seal must be toward inside of housing.
3. Install seal (2) in housing with tooling (B). The lip of seal must be toward the inside of housing.

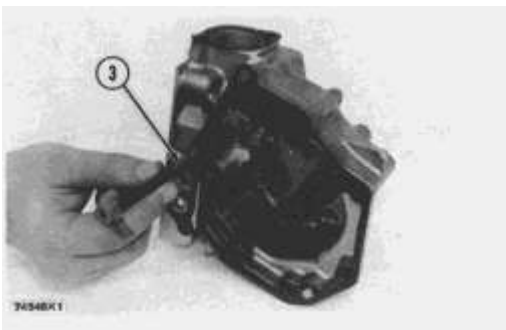

4. Install shaft (3) in the housing.

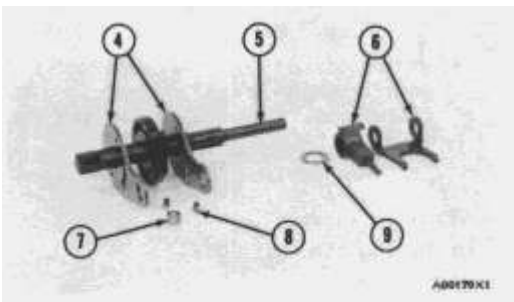

5. Install plates (4), spacers (8) and pin (7) on shaft.
6. Install shaft (5) in housing and through washer (9) and levers (6).

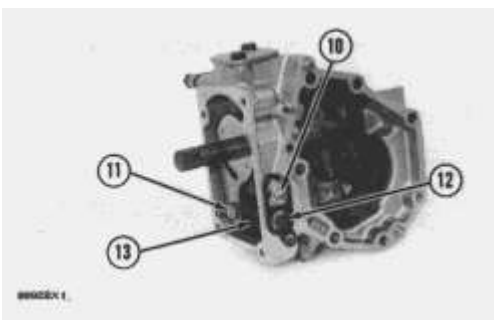

7. Install pin (11) in holes of the plates.

8. Install screw (10) and locknut for high idle adjustment.
9. Install spring (13) and guide.
10. Install bolts (12) and washer for low idle adjustment.

NOTICE

After the fuel injection pump housing and governor have been installed on the engine, make an adjustment for the high and low idle. See GOVERNOR ADJUSTMENT as shown in TESTING AND ADJUSTING.

11. Push plate and pin (11) over toward the bolt (12) and tighten the bolt.
12. Install seal in cover with tooling (B). The lip of seal must be toward the inside.

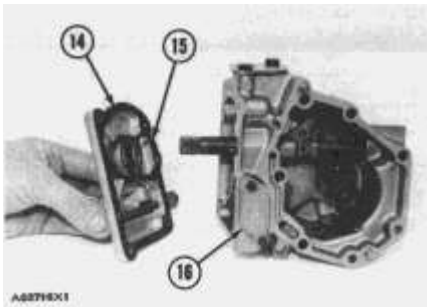

13. Install spring (15) in the cover. Install cover (14) on housing.

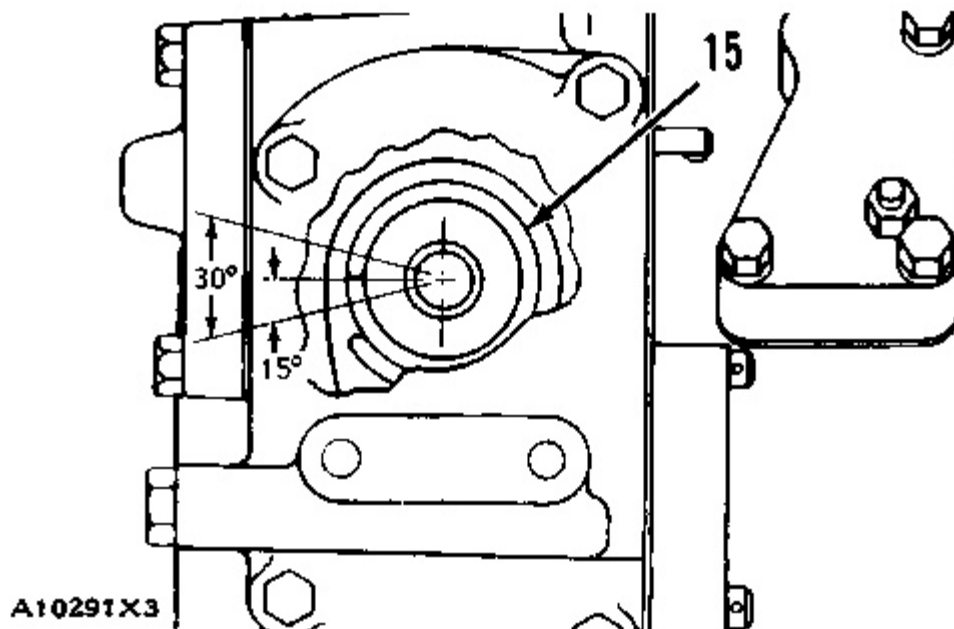

NOTICE

The spring (15) must be installed with the end of spring as shown.

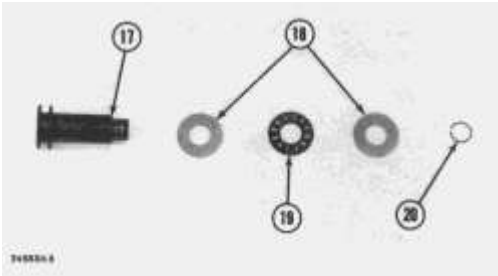

14. Install cover (16) for the idle adjustment screws.

15. Install bearing (19) between the races (18) on riser (follower) (17). Install ring (20) that holds the washers on the riser (follower).

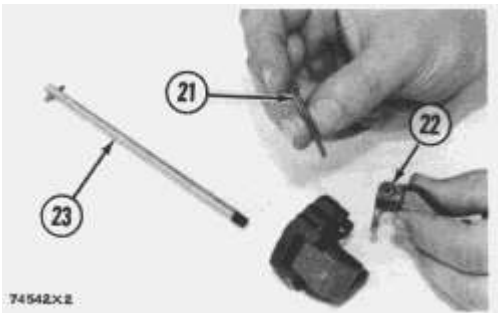

16. Install pin in shaft (23).

17. Install flyweights (22) and pin (21).

18. Install shaft (23) in the flyweight assembly.

end by:

a) connection of governor to fuel injection pump housing.

Product: TRACK LOADER

Model: 977K TRACK LOADER 48J

Configuration: 977L TRAXCAVATOR 48J02011-UP (MACHINE) POWERED BY 3306 ENGINE

Disassembly and Assembly 3306 VEHICULAR ENGINE FOR 977L TRACK-TYPE LOADER

Media Number -SEN7773-00

Publication Date -01/03/1978

Date Updated -12/10/2001

Fuel Transfer Pump

SMCS - 1256-11; 1256-12

Remove Fuel Transfer Pump

Tools Needed		A	B
2P8315	Bracket Assembly	1	
2H3740	Bolt		1

start by:

a) remove fuel injection pump housing and governor

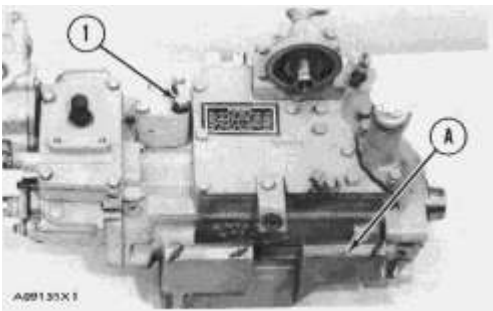

1. Install the fuel injection pump housing on tool (A).

NOTE: The fuel filter does not have to be removed to remove the fuel transfer pump.

2. Install timing pin (1) to keep the injection pump camshaft from turning during disassembly and assembly.

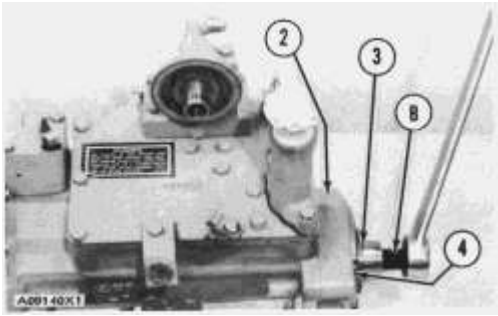

3. Install bolt (B) in the threads of sleeve (3). Tighten the bolt until the sleeve can be removed.

NOTICE

Do not hit on the bolt or sleeve. This will cause damage to the unit.

4. Remove four bolts (4) that hold the pump body to the housing.
5. Remove body (2) from the housing.

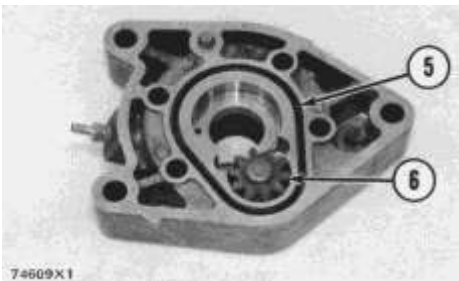

6. Remove idler gear (6) from the pump body.
7. Remove O-ring seal (5) and the two lip-type seals from the body.

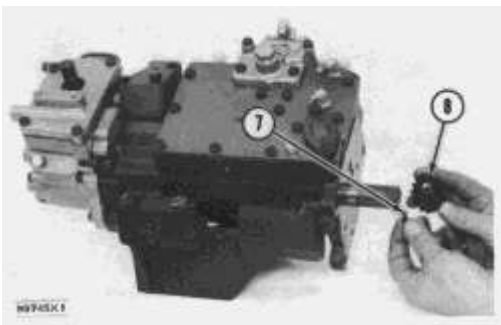

8. Remove drive gear (8) from the shaft.
9. Remove key (7) from the shaft.

Install Fuel Transfer Pump

Tools Needed		A	B	C
1P529	Handle	1	1	
1P463	Drive Plate	1		
5P318	Drive Plate	1		
5P319	Drive Plate		1	
S1603	Bolt			1
4B4280	Washer			1
4N3371	Washer			1

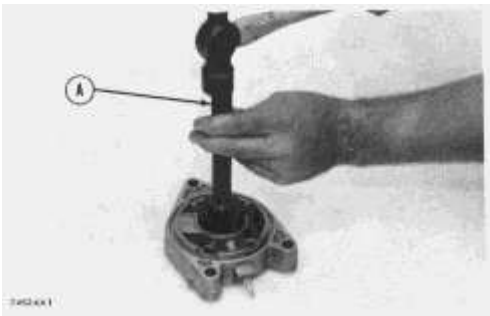

1. Install the inner seal in the body with tool (A). The lip of the seal must be toward the pump gears.
2. Install the outer seal in the body with tool (B). The lip of the seal must be toward the outside.

NOTICE

Always be careful not to scratch or cause damage to the machined surface of the pump body.

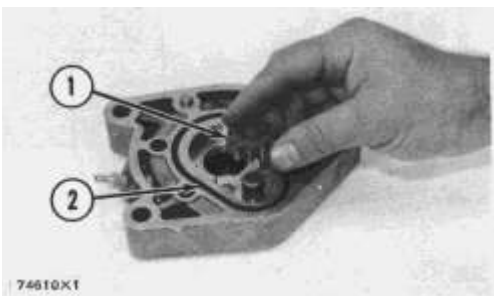

3. Install O-ring seal (2) and idler gear (1) on the body.

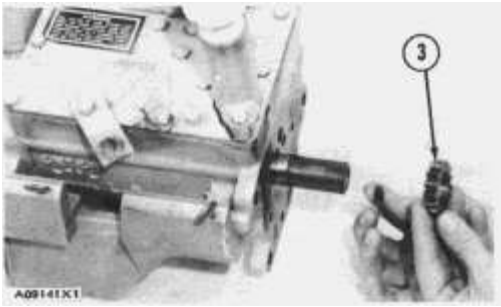

4. Install the key and drive gear (3) on the shaft.

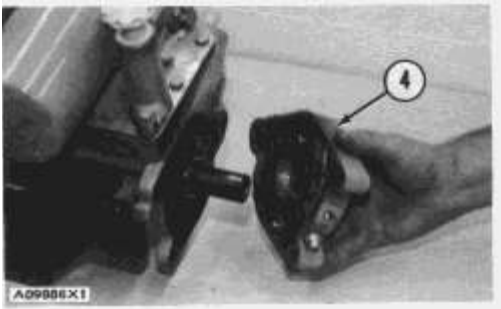

5. Install body (4) on the housing.

6. Install the bolts that hold the body to the housing.

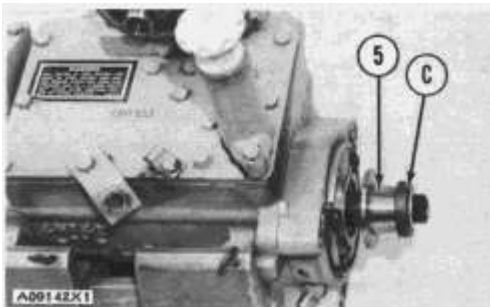

7. Put sleeve (5) in position on the camshaft.

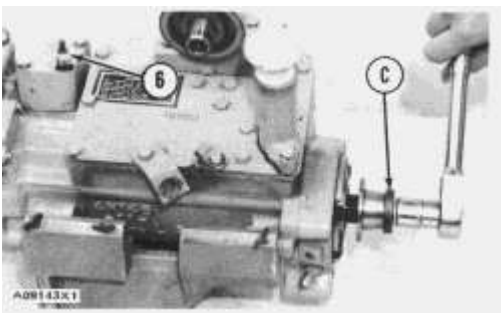

NOTE: Timing pin (6) must be in position as shown to keep the camshaft from turning during assembly.

8. Install the sleeve on the camshaft with tool (C).

NOTICE

Do not hit the sleeve with a hammer to install it. This will put end force on the camshaft and cause damage to the other components in the pump housing.

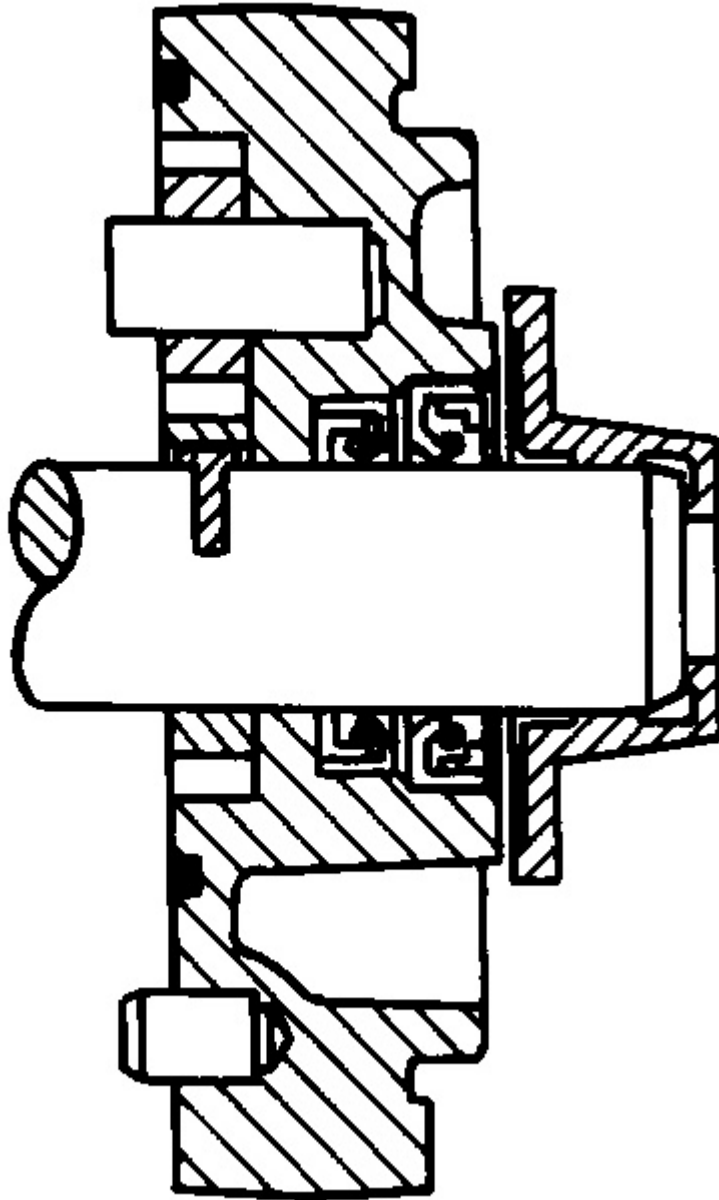

75111x2

9. The end clearance of the camshaft must be $.023 \pm .018$ in. (0.58 ± 0.46 mm) after sleeve (5) is installed.

end by:

a) install fuel injection pump housing and governor.

Product: TRACK LOADER

Model: 977K TRACK LOADER 48J

Configuration: 977L TRAXCAVATOR 48J02011-UP (MACHINE) POWERED BY 3306 ENGINE

Disassembly and Assembly 3306 VEHICULAR ENGINE FOR 977L TRACK-TYPE LOADER

Media Number -SEN7773-00

Publication Date -01/03/1978

Date Updated -12/10/2001

Fuel Check Valve And Bypass Valve

SMCS - 1256-11; 1256-12

Remove Fuel Check Valve And Bypass Valve

Tools Needed		A
2P8315	Bracket Assembly	1

NOTICE

Clean the outer surface of the fuel injection pump housing and governor before removal of the fuel check valve and bypass valve.

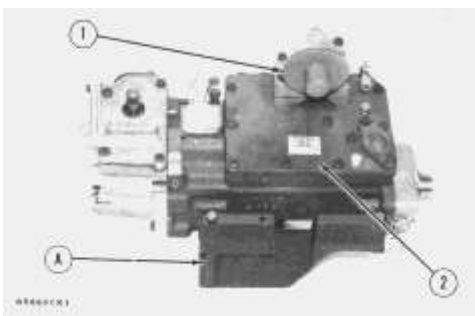

1. Remove fuel filter base (1). Remove the bolts that hold cover (2) in position. Remove the cover.

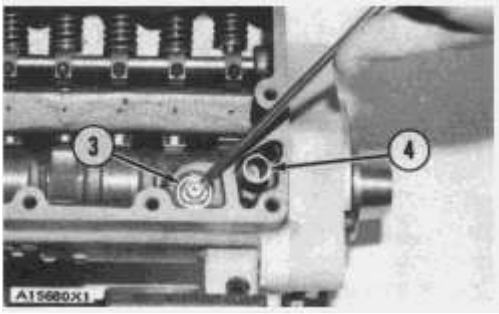

2. Remove check valve (3).
3. Remove spring (4) and the bypass valve.

Install Fuel Check Valve And Bypass Valve

Tools Needed		A
2P8315	Bracket Assembly	1

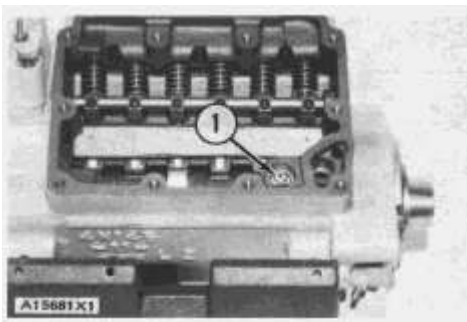

1. Install check valve (1) in the fuel injection pump housing. Make sure the check valve is installed evenly in the fuel injection pump housing.

NOTE: Do not install a check valve that is bent.

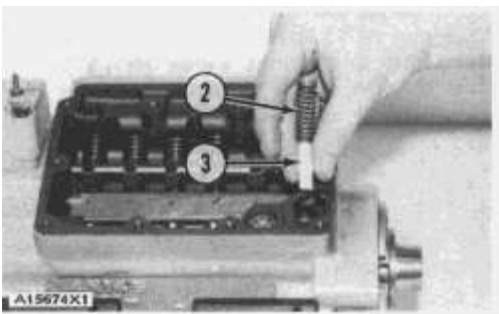

2. Install bypass valve (3) and spring (2) in the fuel injection pump housing.
3. Put the cover in position on the fuel injection pump housing. Make sure the spring on the bypass valve is in the cover. Install the nine bolts that hold the cover in position.
4. Install the fuel filter base.

Product: TRACK LOADER

Model: 977K TRACK LOADER 48J

Configuration: 977L TRAXCAVATOR 48J02011-UP (MACHINE) POWERED BY 3306 ENGINE

Disassembly and Assembly 3306 VEHICULAR ENGINE FOR 977L TRACK-TYPE LOADER

Media Number -SEN7773-00

Publication Date -01/03/1978

Date Updated -12/10/2001

Fuel Injection Pumps

SMCS - 1251-12; 1251-15; 1251-16; 1251-11

Remove Fuel Injection Pumps

Tools Needed		A
8S2243	Wrench	1

NOTICE

Before any service work is to be done on the fuel system the outer surface of the injection pump housing must be clean.

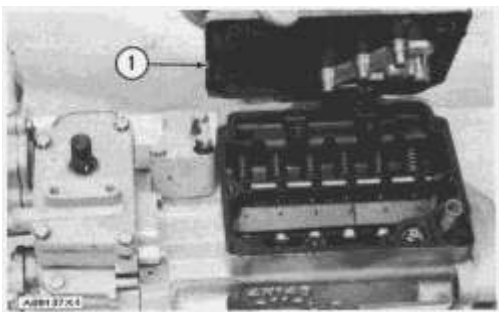

1. Remove cover assembly (1) from the pump housing. Remove the spring for the bypass valve.

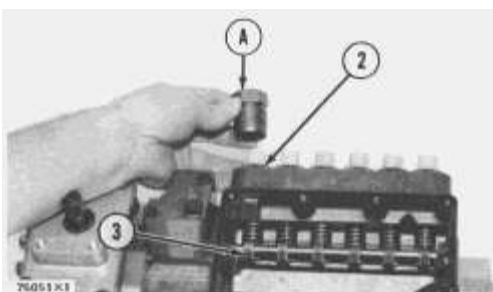

2. Loosen bushing (2) from the pump housing with tool (A).

NOTE: Do not loosen screws (3) when the pumps are removed or installed. If the levers are moved, the fuel pump adjustment will be changed.

3. Remove the fuel injection pump from the pump housing. The sleeve on the plunger will slide off the lever as the pump is removed.

Install Fuel Injection Pumps

Tools Needed		A
8S2243	Wrench	1

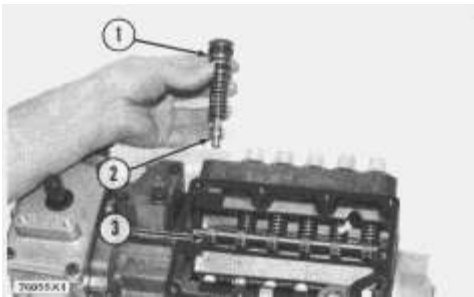

1. Put fuel injection pump (1) in the bore of the pump housing.

2. Sleeve (2) must be engaged with lever (3) when installed correctly.

NOTICE

If the levers (3) have been moved on the shaft, fuel pump adjustment must be made. See TESTING AND ADJUSTING.

3. Tighten the bushing with tool (A) to a torque of 70 ± 5 lb.ft. (95 ± 7 N·m).

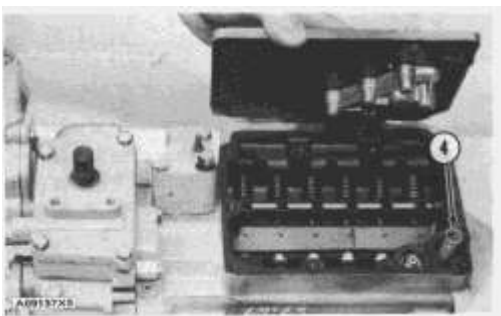

4. Put the spring and bypass valve in place. Install the cover assembly on the pump housing. Be sure spring (4) is in position in the cover.

Disassemble Fuel Injection Pumps

start by:

a) remove fuel injection pumps

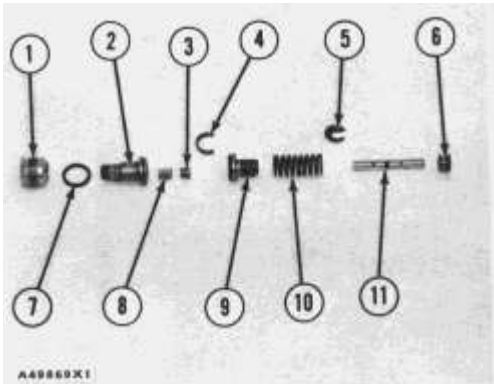

1. Remove bushing (1) and seal (7) from bonnet (2).

2. Remove ring (4) from the bonnet and barrel (9). Remove check valve (3) and spring (8) from the bonnet.

3. Remove spring (10) and washer (5). Remove plunger (11) and sleeve (6).

NOTE: Keep the plunger and sleeve with their respective barrel for installation. Do not use plungers, sleeves or barrels with other plungers, sleeves or barrels.

Assemble Fuel Injection Pumps

Thank you so much for reading.
Please click the “Buy Now!”
button below to download the
complete manual.



After you pay.

You can download the most
perfect and complete manual in
the world immediately.

Our support email:

ebooklibonline@outlook.com