

Product: WHEEL LOADER
Model: 980B WHEEL LOADER 89P
Configuration: 980B WHEEL LOADER 89P00001-02167 (MACHINE)

Disassembly and Assembly 980 WHEEL LOADER ENGINE

Media Number -REG00991-00

Publication Date -01/06/1975

Date Updated -10/10/2001

Fuel Injection Pump Housing & Governor

SMCS - 1286-12; 1286-11

Remove Fuel Injection Pump Housing And Governor As A Unit

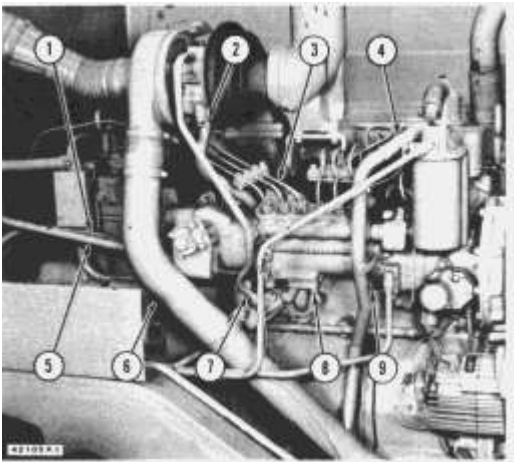

1. Disconnect governor control linkage (5) from governor.
2. Disconnect fuel ratio control sensing line (1) from fuel ratio control.
3. Remove turbocharger-to-aftercooler air pipe (6). Remove turbocharger oil supply line (7) and oil drain line (2).
4. Remove crankcase breather pipe (4).
5. Remove all fuel injection lines (3). Plug or cap all fuel lines and openings.
6. Remove six fuel injection pump housing-to-accessory drive housing mounting bolts (9).
7. Remove two elbow-to-fuel injection pump housing mounting bolts (8).

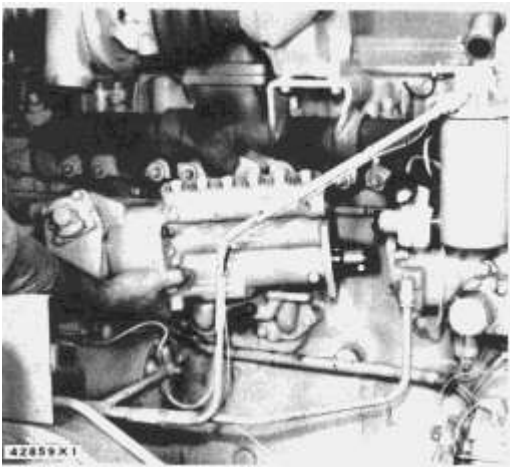

8. Remove fuel injection pump housing and governor as a unit-weight 50 lbs. (23 kg).

Install Fuel Injection Pump Housing And Governor As A Unit

| Tools Required | | A | B |
|----------------|----------------------|---|---|
| 8S5417 | Timing Fixture Plate | 1 | |
| 8S5132 | Puller Plate | | 1 |
| 8S5133 | Expansion Plug | | 1 |
| 8S6470 | Pressure Screw | | 1 |
| 8S8375 | Sleeve | | 1 |
| 8B7561 | Step Plate | | 1 |
| 3/8"–24NF Bolt | 3-1/2" long | | 2 |
| 3/8" | Flat Washer | | 2 |

1. Locate top dead center compression stroke for No. 1 piston. See LOCATING TOP DEAD CENTER COMPRESSION POSITION FOR NO. 1 PISTON in TESTING AND ADJUSTING.

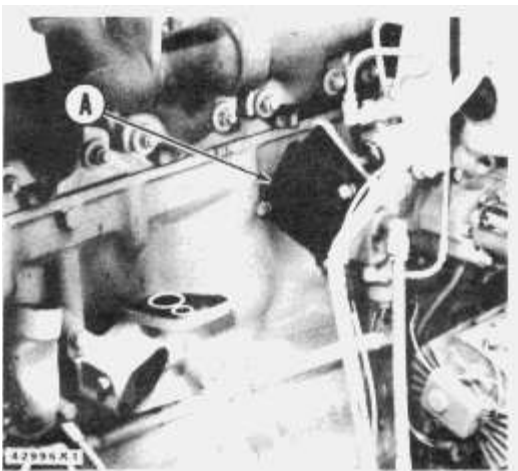

2. Install the timing fixture plate (A) on the rear face of the accessory drive housing.
3. If the plate can be installed with the dowels in the accessory drive housing aligned with dowel holes in plate, the accessory drive shaft is correctly timed. Proceed to Step 8. If plate cannot be installed, continue with Step 4.
4. Remove the small cover from the front of the timing gear cover. Remove the timing gear retaining nut and washer.

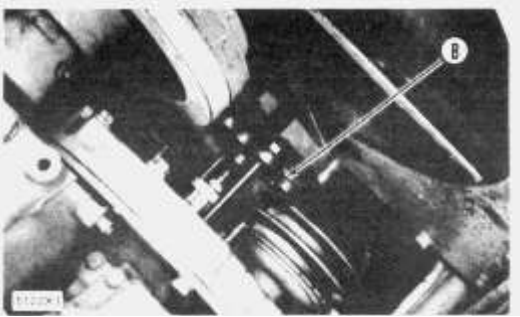

5. Using tool (B), separate gear from accessory drive shaft. Rotate accessory drive shaft until timing fixture plate (A) can be installed.
6. Install conical washer on drive shaft with the O.D. in contact with gear. Install and tighten retaining nut to 100 ± 10 lb. ft. ($13,8 \pm 1,4$ mkg).
7. Install the cover on front of timing gear cover, and remove timing fixture plate (A).
8. Position fuel injection pump housing and governor on engine, and install all mounting bolts.
9. Remove all caps and plugs from lines and openings. Install fuel injection lines. Tighten fuel injection line retaining nuts to 30 ± 5 lb. ft. ($4,1 \pm 0,7$ mkg).
10. Install crankcase breather pipe, turbocharger oil supply line, and oil drain line.
11. Install turbocharger-to-aftercooler air pipe. Connect fuel ratio control sensing line and governor control linkage.

Separate Governor From Fuel Injection Pump Housing

preparatory steps:

- a) remove fuel injection pump housing and governor as a unit
- b) remove fuel ratio control

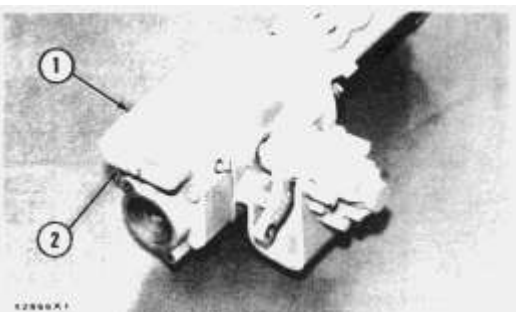

1. Remove the idle screw cover (2).
2. Remove the idle screw housing (1).

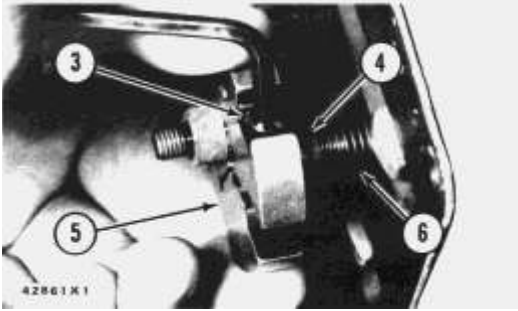

3. Remove rack stop collar retaining screw (3).
4. Remove the rack stop collar (5), collar (4), and spring (6).
5. Remove the governor-to-fuel injection pump housing mounting bolts.

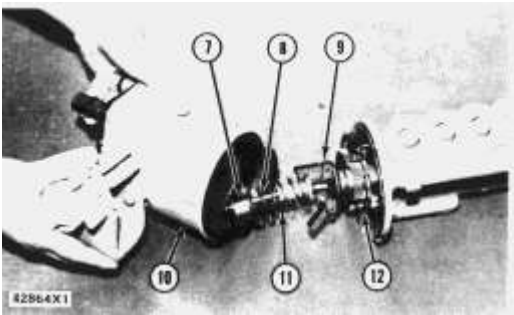

6. Remove the governor housing (10).
7. Remove the governor spring (11), seat assembly (7), and washer-type spring (8).
8. Remove the three mounting bolts (12) and lock that secure the cylinder and weight assemblies (9) to the fuel injection pump housing.
9. Pull the cylinder and weight assemblies straight out to clear locating dowels.

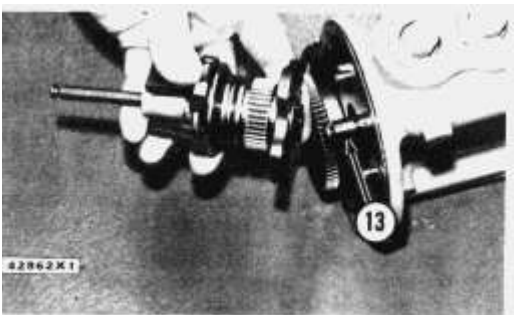

10. Slide the cylinder and weight assemblies sideways to disengage slot in piston from the rack (13).

Connect Governor To Fuel Injection Pump Housing

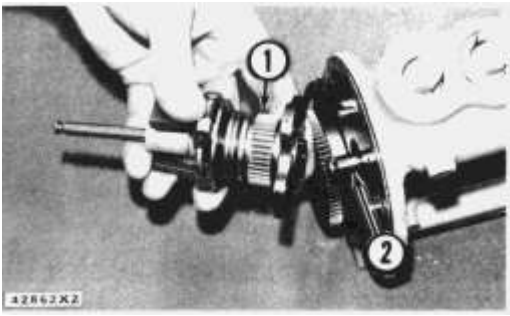

1. Position the cylinder and weight assemblies (1) on the fuel injection pump housing so that slot in piston is engaged with the rack (2).

2. Push the cylinder and weight assemblies onto the locating dowels.

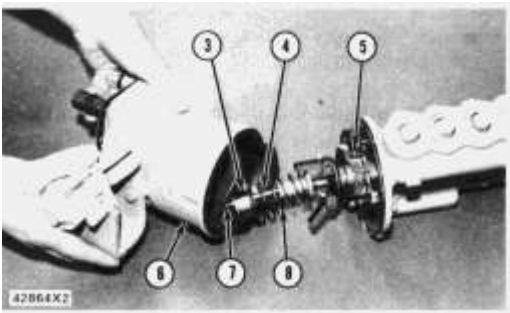

3. Install the three mounting bolts (5) and lock.

4. Install the washer-type spring (4), seat assembly (3), and governor spring (8) on the cylinder assembly. The washer-type spring (4) should be installed so that the inside diameter of spring will contact the guide in governor housing (6).

5. Position the governor housing (6) on the fuel injection pump housing, and install the governor mounting bolts.

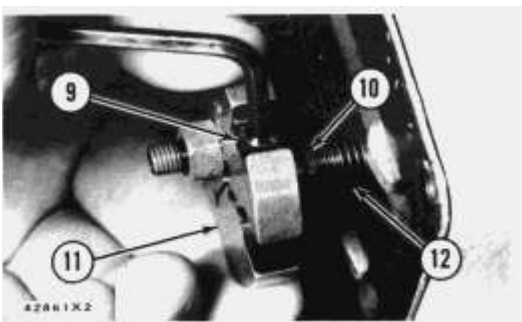

6. Install the spring (12), collar (10), and rack stop collar (11) on bolt (7).

7. Install and tighten the rack stop collar retaining screw (9).

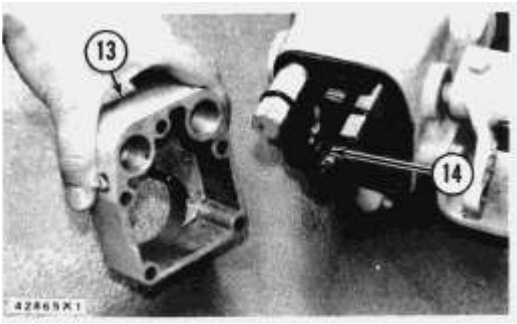

8. Position the idle screw housing (13) on the governor so that dowel in housing engages slot (14) in rack stop collar (11).

9. Install the idle screw cover.

concluding steps:

a) install fuel ratio control

b) install fuel injection pump housing and governor as a unit

c) set the rack and adjust governor (See FUEL RACK SETTING AND GOVERNOR ADJUSTMENTS in TESTING AND ADJUSTING)

Product: WHEEL LOADER
Model: 980B WHEEL LOADER 89P
Configuration: 980B WHEEL LOADER 89P00001-02167 (MACHINE)

Disassembly and Assembly 980 WHEEL LOADER ENGINE

Media Number -REG00991-00

Publication Date -01/06/1975

Date Updated -10/10/2001

Governor

SMCS - 1264-16; 1264-15

Disassemble Governor

preparatory steps:

- a) separate governor from fuel injection pump housing
- b) remove decelerator dashpot

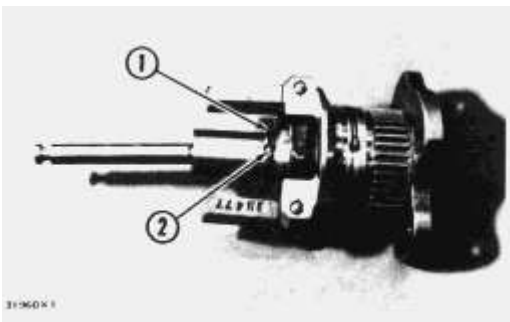

1. Remove seat retaining ring (1) and pin (2).

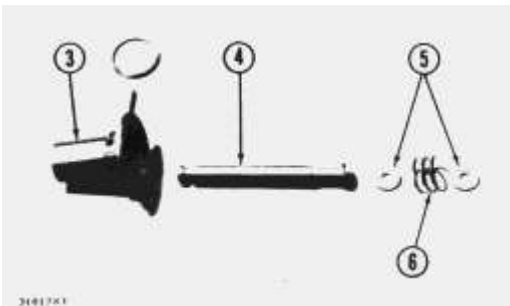

2. Remove seat (3), bolt (4), washers (5), and spring (6).
3. Remove the sleeve and bearing assembly from the cylinder and weight assemblies.

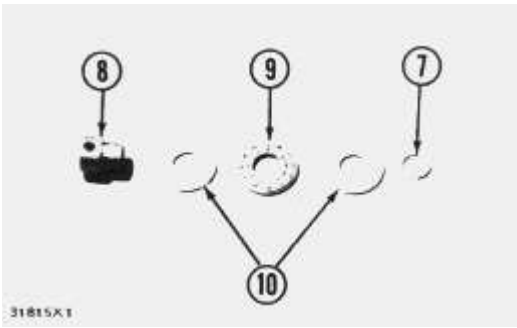

4. Remove retaining ring (7) from sleeve (8).
5. Remove bearing (9) and races (10) from sleeve (8).

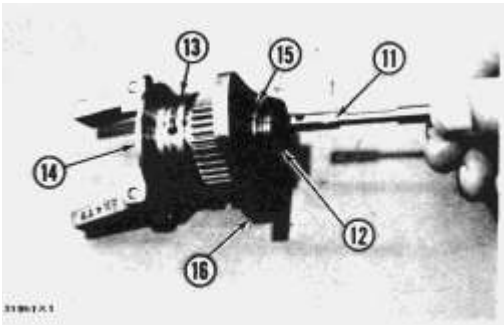

6. Remove the valve (11) from piston (12).
7. Remove the cylinder-to-weight assembly retaining ring (13).
8. Remove the weight assembly (14).
9. Remove piston (12) and sleeve (15) from the cylinder (16).
10. Remove the O-ring seal from the sleeve (15).
11. Remove decelerator control linkage and bracket from governor housing.

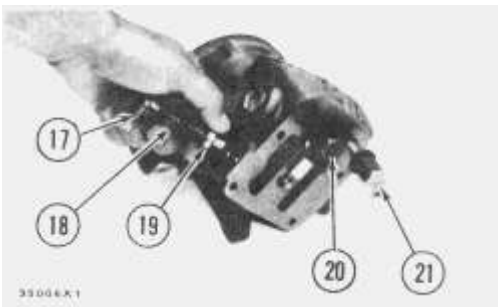

12. Remove the speed limiter plug (17), spring (18), and plunger (19) from the governor housing.
13. Remove the high idle screw (21) and low idle screw (20).

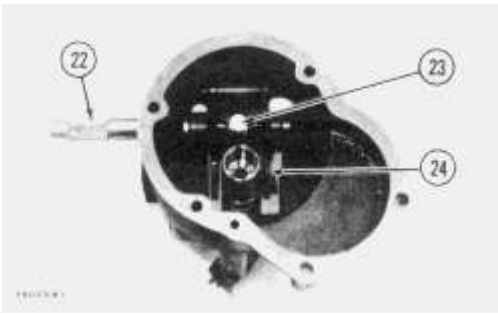

14. Remove the lever assembly-to-shaft assembly retaining bolt (23) and lock.
15. Remove the shaft assembly (22) and lever assembly (24) from governor housing.
16. Remove the seal from governor housing.

Assemble Governor

| Tools Required | | A |
|----------------|-------------|---|
| 1P529 | Handle | 1 |
| 1P463 | Drive Plate | 1 |

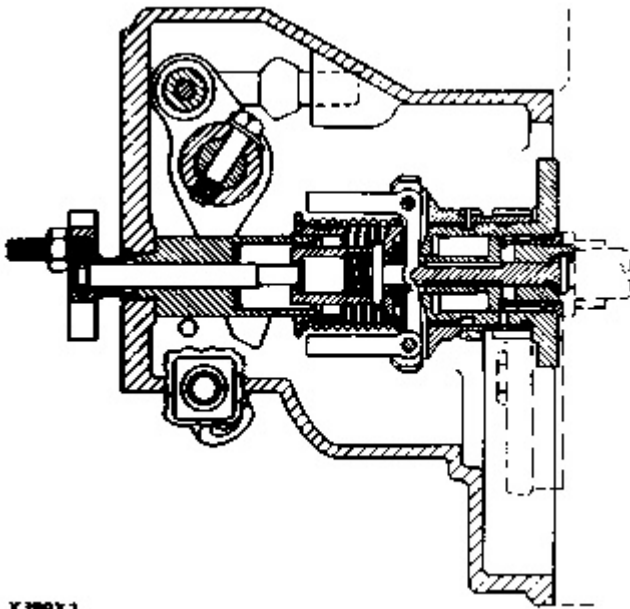

1. Using tool (A), install the seal in the governor housing with spring side of seal toward inside of governor housing. Lubricate lip of seal with clean SAE 30 engine oil.
2. Position the lever assembly and shaft in the governor housing. Install the retaining bolt and lock.
3. Install the high and low idle screws in the governor housing.
4. Install the speed limiter plug, spring, and plunger in the governor housing.
5. Install decelerator control linkage and bracket from governor housing.

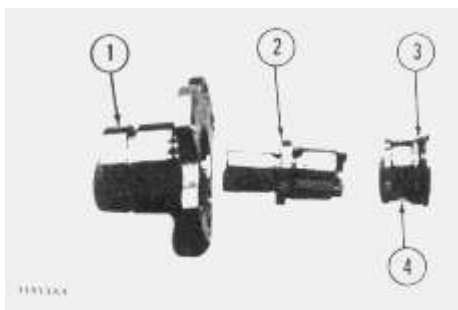

6. Install the O-ring seal (3) on sleeve (4).
7. Install piston (2) and sleeve (4) in the cylinder (1).

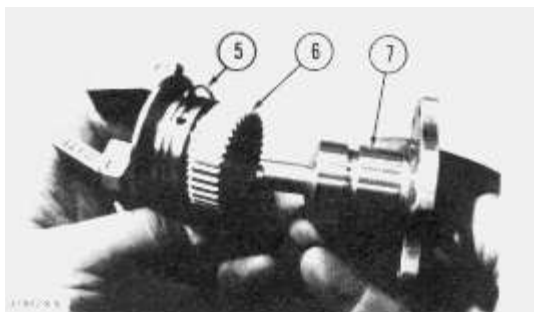

8. Position the weight assembly (6) on cylinder (7) and install retaining ring (5).

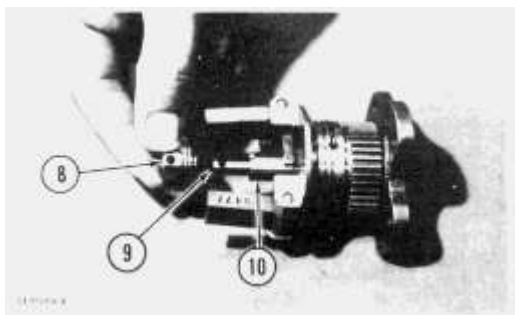

9. Install the valve (9) in piston (10).
10. Install the bearing and races in sleeve. Install retaining ring. Install the sleeve and bearing assembly (8) on valve (9).

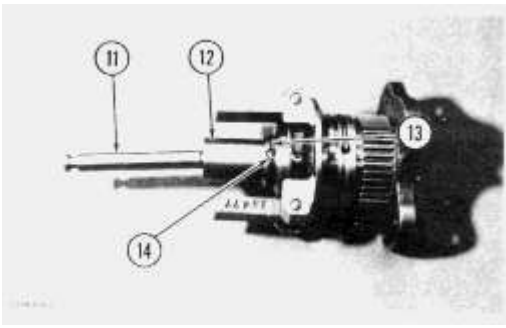

11. Position the seat (12), bolt (11), washers, and spring on the valve (9). Install the retaining pin (14) and ring (13).

concluding steps:

- a) connect governor to fuel injection pump housing
 - b) install decelerator dashpot
-

Product: WHEEL LOADER
Model: 980B WHEEL LOADER 89P
Configuration: 980B WHEEL LOADER 89P00001-02167 (MACHINE)

Disassembly and Assembly 980 WHEEL LOADER ENGINE

Media Number -REG00991-00

Publication Date -01/06/1975

Date Updated -10/10/2001

Fuel Injection Pump Housing

SMCS - 1253-15; 1253-16

Disassemble Fuel Injection Pump Housing

| Tools Required | | A | B | C |
|----------------|--|---|---|---|
| 8S4613 | Wrench | 1 | | |
| 8S2244 | Extractor | | 1 | |
| 8S2241 | Camshaft Bearing Installation & Removal Tool Group | | | 1 |

preparatory step:

a) separate governor from fuel injection pump housing

1. Remove the fuel injection pumps as follows:

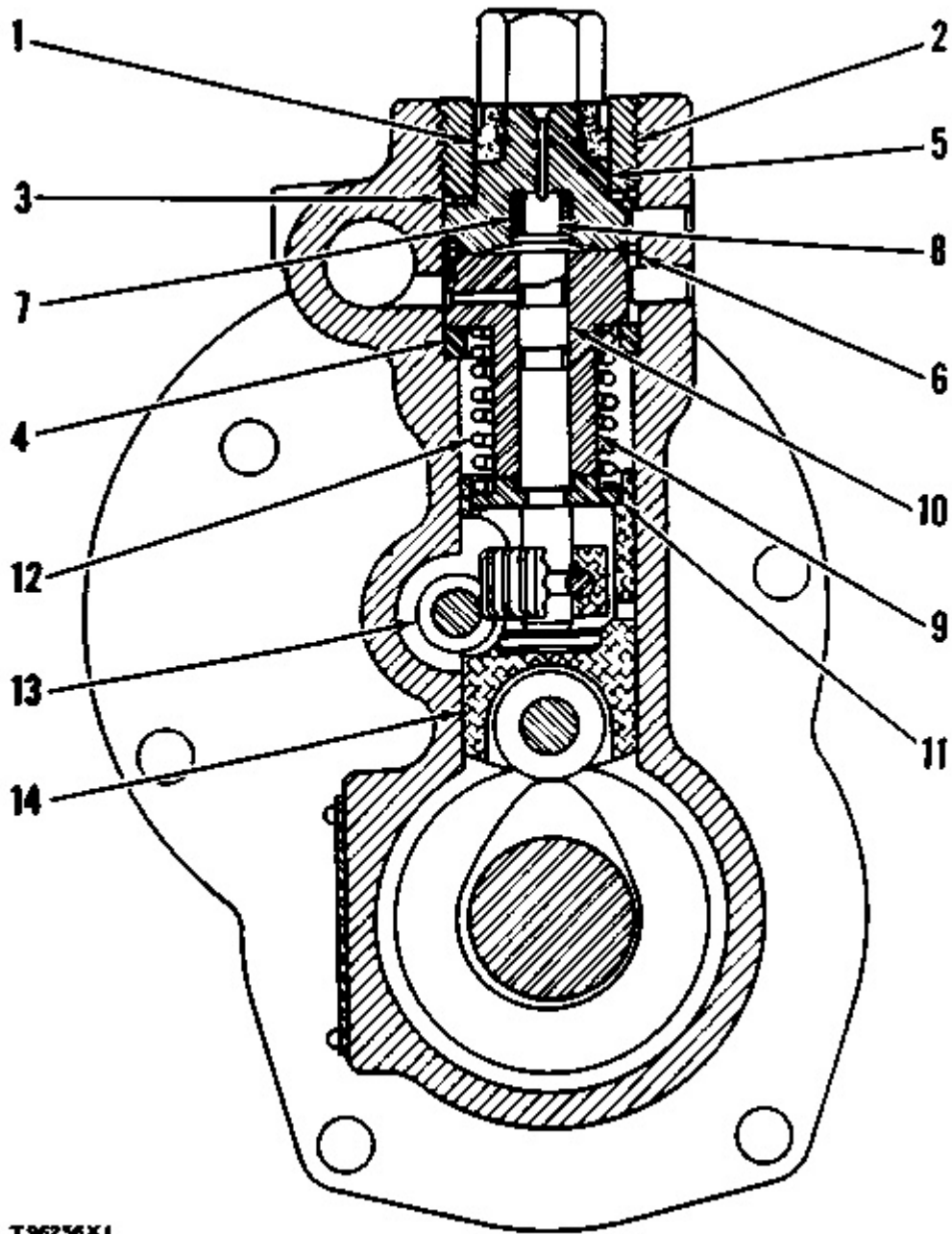

a) Remove the protective cap and the felt washer (1).

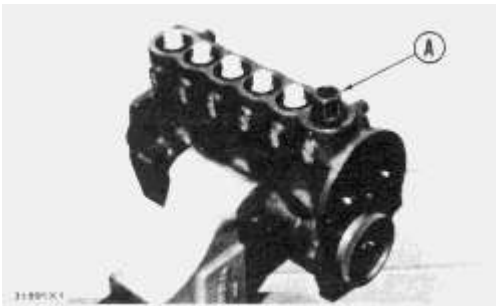

b) Install wrench (A) and remove retaining bushing (2) from housing.

c) Remove seal (3).

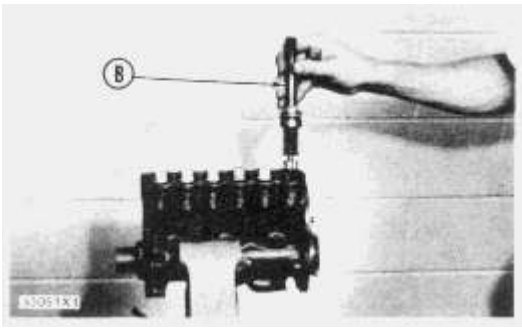

- d) Install extractor (B).
- e) Lift the fuel injection pump out of the housing.
- f) Remove the spacer (4). Keep the spacers (4) and pumps together, and identified as to their location in the fuel injection pump housing.

2. Disassemble the fuel injection pumps as follows:

- a) Remove the bonnet (5), ring (6), spring (7), and check valve (8) from the barrel (9).
- b) Remove the plunger assembly (10), washer (11), and spring (12) from the barrel (9).

NOTICE

While disassembling and assembling fuel injection pumps, exercise considerable care to prevent damage to plunger surfaces. The barrel and plunger assemblies are matched, and the individual parts are not interchangeable with other barrels or plunger assemblies.

- 3. Remove the rack (13).
- 4. Remove the lifters (14). Keep the lifters identified and together with their respective pumps and spacers.

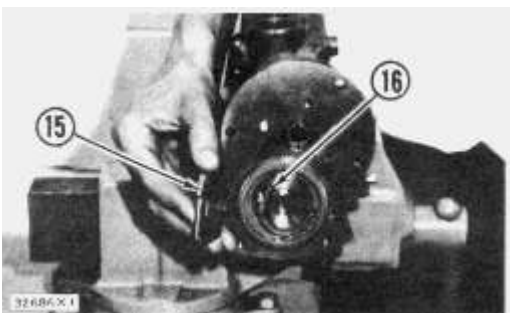

- 5. Remove the camshaft retaining plate (15), bolt, and lock.

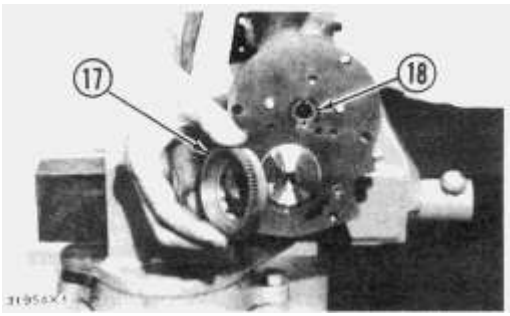

6. Remove the spring (16) and the gear assembly (17) from the camshaft.

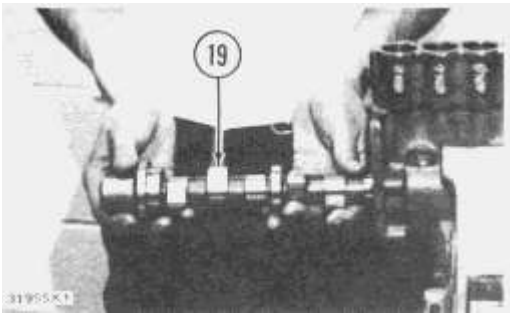

7. Remove the camshaft (19).

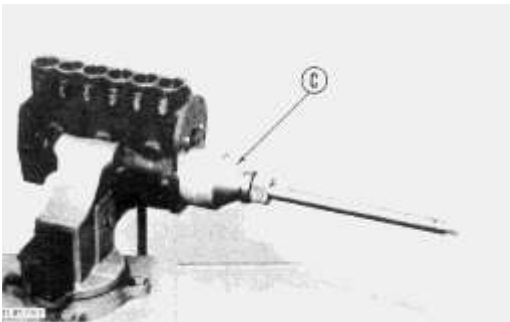

8. Using tool group (C), remove the camshaft bearings from the fuel injection pump housing.

9. Remove the two rack bearings (18) from the fuel injection pump housing.

Assemble Fuel Injection Pump Housing

| Tools Required | | A | B | C | D | E |
|----------------|--|---|---|---|---|---|
| 8S4613 | Wrench | 1 | | | | |
| 8S2244 | Extractors | | 1 | | | |
| 8S2241 | Camshaft Bearing Installation & Removal Tool Group | | | 1 | | |
| 1P529 | Handle | | | | 1 | |
| 1P460 | Drive Plate | | | | 1 | |
| 1P455 | Drive Plate | | | | 1 | |
| 7S7113 | Rack Setting Gauge | | | | | 1 |
| FT960 | Fuel Injection Pump Installation Tool Group | | | | | 1 |

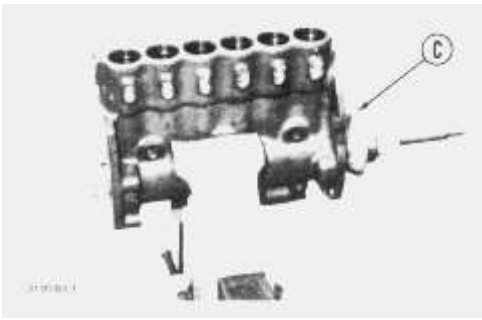

1. Using tool group (C), install the camshaft bearings in the fuel injection pump housing. Install the bearing in governor end of housing so that the oil hole in bearing is aligned with oil hole in housing. Install the two end camshaft bearings flush with their respective ends of fuel injection pump housing.

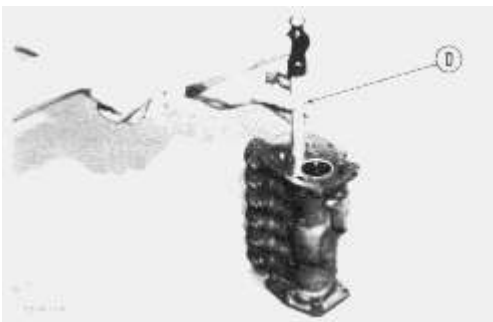

2. Using tool setup (D), install the two rack bearings in the fuel injection pump housing. Install the bearing in governor end of housing so that it will be recessed $.195 \pm .005$ in. ($4,953 \pm 0,127$ mm) from face of housing. Install the rack bearing in accessory drive end of housing so that it will be flush with face of fuel injection pump housing.

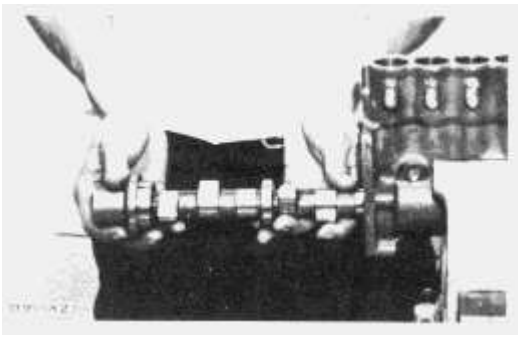

3. Lubricate the camshaft with clean SAE 30 engine oil. Install the camshaft in fuel injection pump housing.

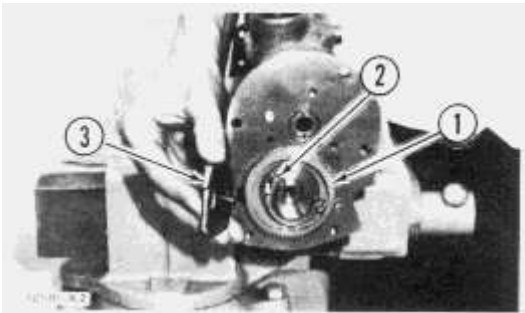

4. Position the governor drive gear (1) and spring (2) on the camshaft. Install the camshaft retaining plate (3), bolt, and lock.

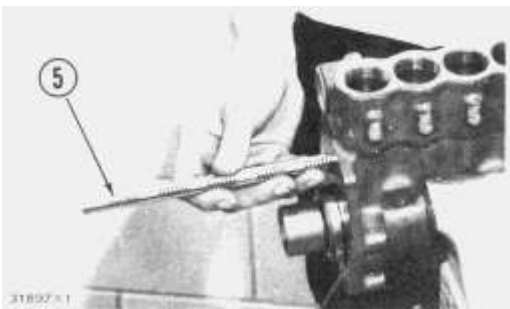
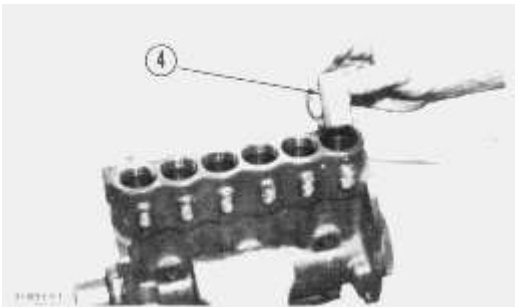

5. Install the lifters (4) in their respective positions in housing. Lubricate the rack generously with clean fuel oil. Install the rack (5) in fuel injection pump housing with the slot in rack toward the governor end of housing.

6. Install the spacers in their respective positions in housing. If new lifters and pumps are to be installed, it will be necessary to set the fuel pump timing dimension. See FUEL INJECTION PUMP TIMING DIMENSION SETTING-OFF ENGINE in TESTING AND ADJUSTING.

7. Assemble the fuel injection pumps as follows:

- a) Lubricate all parts generously with clean fuel oil.
- b) Install the spring, washer, and plunger in the barrel.
- c) Install the spring, check valve, bonnet, and ring on the barrel.

NOTICE

Do not attempt to install fuel injection pumps until the rack has been centered.

8. Using tool setup (E), center the rack as follows:

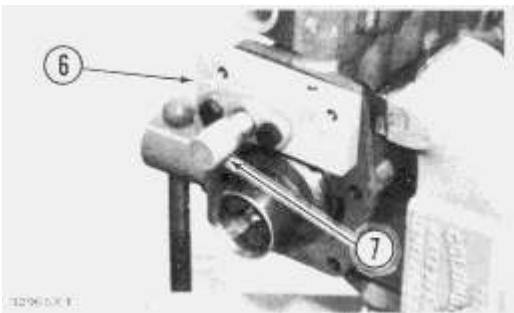

- a) Install locating fixture (6) on the fuel injection pump housing.
- b) Install the rack setting gauge (7). Set the gauge (7) at zero. Push the rack (5) against the gauge.

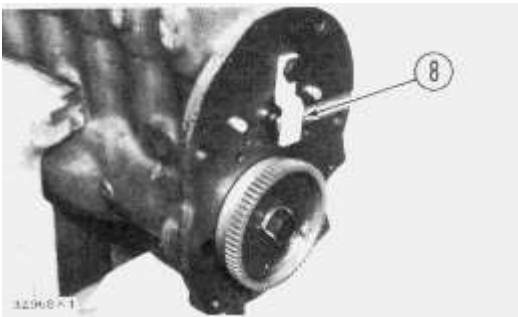

- c) Install the clamp (8) on pump housing as illustrated. This will keep the rack centered while installing the fuel injection pumps.

9. With rack centered, install the fuel injection pumps as follows:

- a) Rotate the camshaft until lobe of camshaft is down for pump to be installed.

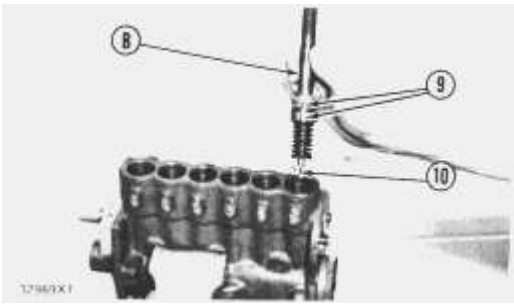

b) Install the extractor (B) on the pump.

c) Sight down the pump, and align the notches (9) in bonnet and barrel with the slot (10) in pump gear segment. The slot should be in line with the center of these notches. Position the pump so the notches align with the guide pins in housing bore. Install the pump in its respective position in housing.



d) Install the seal and retaining bushing (11). Apply a downward force to extractor (B), and tighten the bushing by hand (finger tight only) until bushing is flush with top of housing. If the bushing cannot be installed this far by hand, remove it. Remove pump, realign components, and install again.

NOTICE

**Do not force bushing flush with face of pump housing by using wrench.
If pump has been properly installed, bushing can be finger tightened
flush with face of pump housing.**

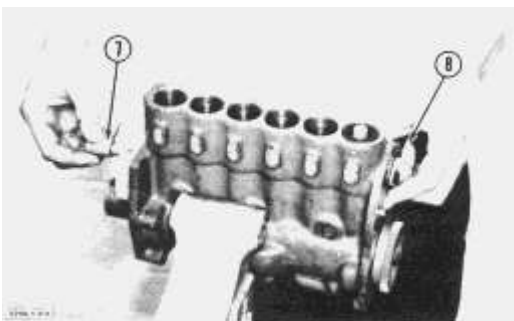

e) After each pump has been installed, check the rack travel in the following manner. Swing the clamp (8) away from end of rack. Using rack setting gauge (7), check the rack travel. If the pump gear has been installed correctly with respect to the rack, total rack travel should be

approximately .800 in. (20,32 mm). If total rack travel cannot be obtained, remove the pump, realign components, and reinstall pump.

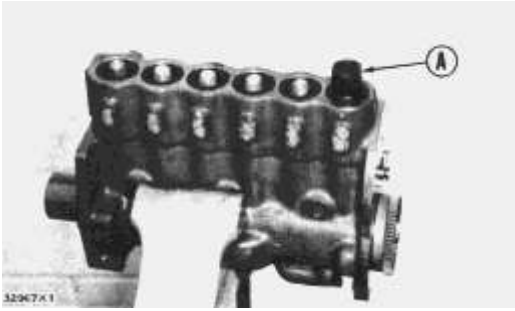

f) Remove the extractor (B) and tool setup (E). Install wrench (A), and tighten retaining bushing to 150 ± 10 lb. ft. ($20,7 \pm 1,4$ mkg). Remove wrench (A). Install the felt washers and protective caps.

concluding steps:

a) connect governor to fuel injection pump housing

b) install fuel injection pump housing and governor as a unit

c) adjust governor and set rack (See GOVERNOR ADJUSTMENTS and FUEL RACK SETTING in TESTING AND ADJUSTING)

Thank you so much for reading.
Please click the “Buy Now!”
button below to download the
complete manual.



After you pay.

You can download the most
perfect and complete manual in
the world immediately.

Our support email:

ebooklibonline@outlook.com