

Product: INDUSTRIAL ENGINE  
Model: C13 INDUSTRIAL ENGINE RRA  
Configuration: C13 Industrial Engine RRA00001-UP

## Disassembly and Assembly C13 Engine and C13 Industrial Engine

Media Number -KENR8165-03

Publication Date -01/11/2017

Date Updated -14/11/2017

i06508733

# Gear Group (Rear) - Remove and Install - Flywheel Housing

SMCS - 1206-010; 1212-010

## Removal Procedure

Table 1

Required Tools			
Tool	Part Number	Part Description	Qty
A	439-3939	Link Bracket	2

### Start By:

- a. Remove the electric starting motor.
- b. Remove the flywheel.
1. Support the engine.

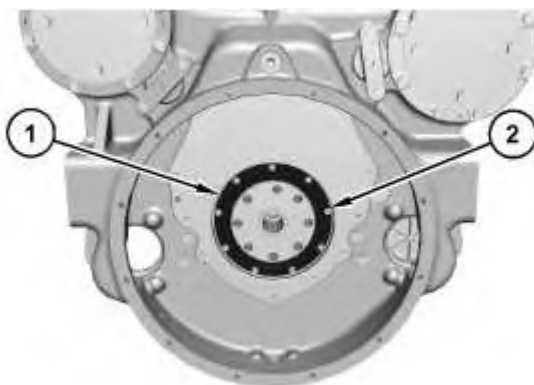

2. Remove bolts (2) and rear crankshaft seal (1).

---

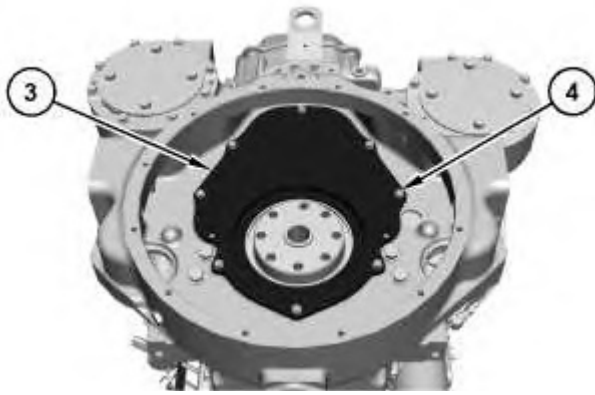

Illustration 2

g06002556

3. Remove bolts (4) and the washers. Remove cover (3) and the seal.

---

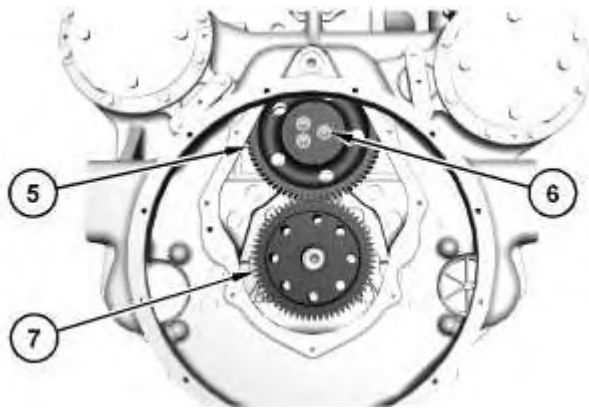

Illustration 3

g06002558

4. Remove gear (7), bolts (6), and gear (5).

---



Illustration 4

g06002564

5. Remove O-ring seal (8) from gear (7).

---

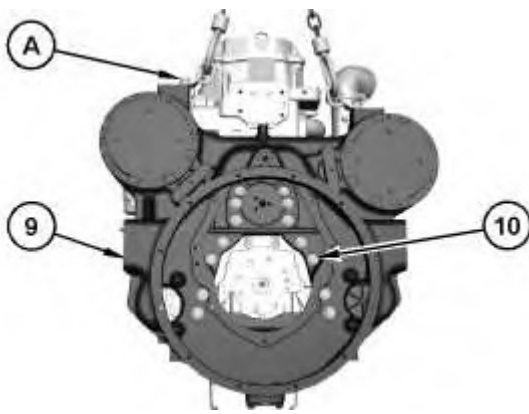

Illustration 5

g06002568

6. Attach Tooling (A) and a suitable lifting device to flywheel housing (9). The weight of flywheel housing (9) is approximately 135 kg (297 lb).
7. Remove bolts (10) and flywheel housing (9).

## Installation Procedure

Table 2

Required Tools			
Tool	Part Number	Part Description	Qty
A	439-3939	Link Bracket	2
B	-	Loctite Anaerobic Flexible Gasket Maker	-
C	095-0706	Bolt	2

1. Apply Tooling (B) to the face of the cylinder block.

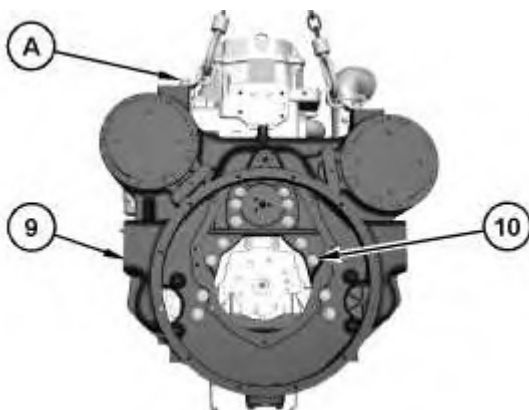

Illustration 6

g06002568

2. Attach Tooling (A) and a suitable lifting device to flywheel housing (9). The weight of flywheel housing (9) is approximately 135 kg (297 lb). Position flywheel housing (9) on the rear of the cylinder block.

3. Install the washers and bolts (10).



Illustration 7

g06002564

4. Install O-ring seal (8) onto gear (7).

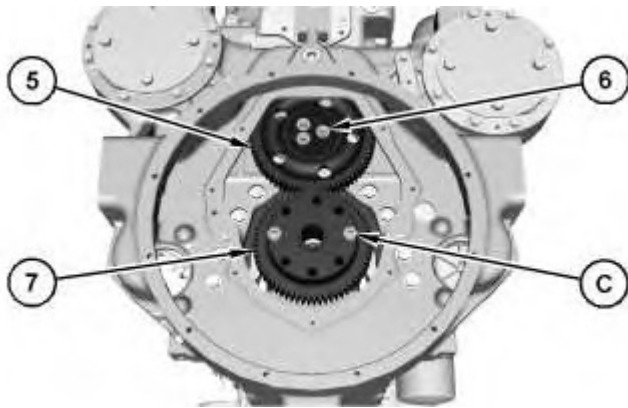

Illustration 8

g06002578

5. Install gear (5) and bolts (6).

**Note:** Tooling (C) is for supporting gear (7) during the installation of the cover and the rear crankshaft seal.

**Note:** The bolt holes in gear (7) are not symmetrical. When installing Tooling (C), check the rest of the bolts holes in gear (7) are aligned with the holes in the crankshaft.

6. Install gear (7) and Tooling (C).
-

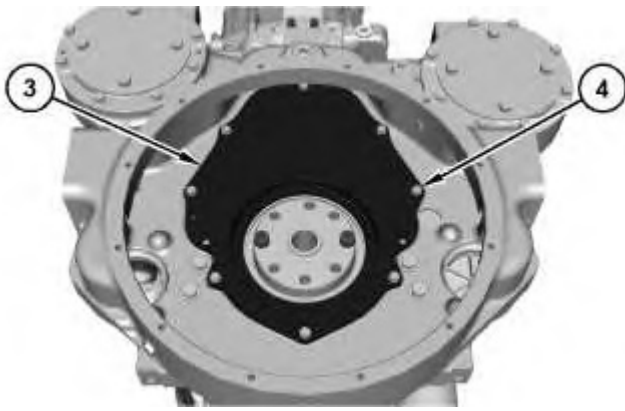

Illustration 9

g06002581

7. Install cover (3), the seal, bolts (4), and the washers.
- 

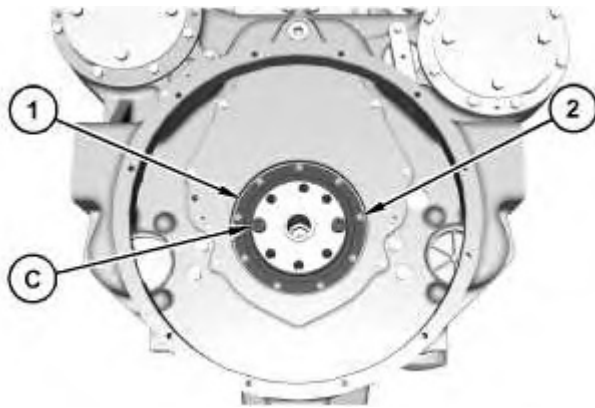

Illustration 10

g06002592

8. Install rear crankshaft seal (1) and bolts (2).
9. Remove Tooling (C).

**End By:**

- a. Install the flywheel.
  - b. Install the electric starting motor.
-

Product: INDUSTRIAL ENGINE  
Model: C13 INDUSTRIAL ENGINE RRA  
Configuration: C13 Industrial Engine RRA00001-UP

## Disassembly and Assembly C13 Engine and C13 Industrial Engine

Media Number -KENR8165-03

Publication Date -01/11/2017

Date Updated -14/11/2017

i03555524

# Boost Pressure Sensor - Remove and Install

SMCS - 1917-010

## Removal Procedure

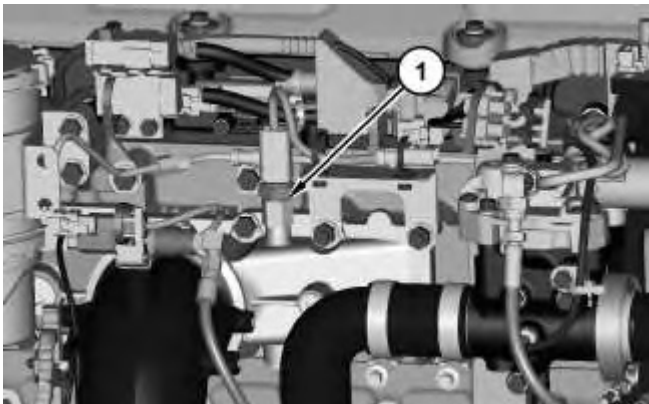

Illustration 1

g01880574

1. Disconnect harness assembly (1) and remove boost pressure sensor (2).

## Installation Procedure

1. Install boost pressure sensor (2) in reverse order of removal.
  - a. Tighten boost pressure sensor (2) to a torque of  $10 \pm 2$  N·m ( $89 \pm 18$  lb in).

Product: INDUSTRIAL ENGINE  
Model: C13 INDUSTRIAL ENGINE RRA  
Configuration: C13 Industrial Engine RRA00001-UP

## Disassembly and Assembly C13 Engine and C13 Industrial Engine

Media Number -KENR8165-03

Publication Date -01/11/2017

Date Updated -14/11/2017

i03542973

# Flywheel - Remove and Install

SMCS - 1156-010

## Removal Procedure

Table 1

Required Tools			
Tool	Part Number	Part Description	Qty
A	FT2712	Guide Stud	2
B	7M-7456	Bearing Mount Compound	-

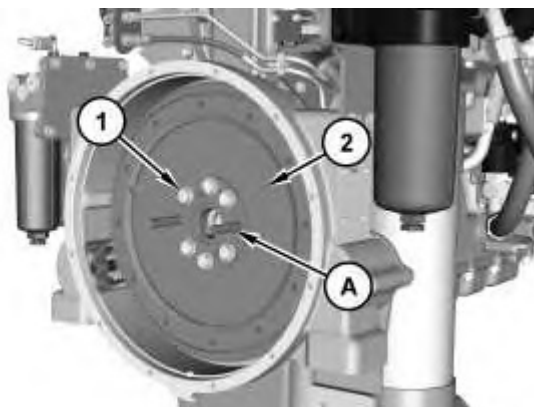

Illustration 1

g01871015

1. Remove two of bolts (1) and install Tooling (A).
2. Use two people to remove flywheel (2). The weight of flywheel (2) is approximately 41 kg (90 lb). Remove remaining bolts (1) and flywheel (2).

3. Use a hammer and a punch in order to remove the ring gear.

## Installation Procedure



**Always wear protective gloves when handling parts that have been heated.**

---

1. Install flywheel (2) in reverse order of removal.
    - a. Raise the temperature of the ring gear. Use a soft hammer in order to seat the ring gear on the flywheel.
    - b. Apply Tooling (B) to the threads of bolts (1).
-



Product: INDUSTRIAL ENGINE  
Model: C13 INDUSTRIAL ENGINE RRA  
Configuration: C13 Industrial Engine RRA00001-UP

## Disassembly and Assembly C13 Engine and C13 Industrial Engine

Media Number -KENR8165-03

Publication Date -01/11/2017

Date Updated -14/11/2017

i06010869

# Crankshaft Rear Seal - Remove and Install

SMCS - 1161-010

## Removal Procedure

Start By:

- a. Remove the flywheel.

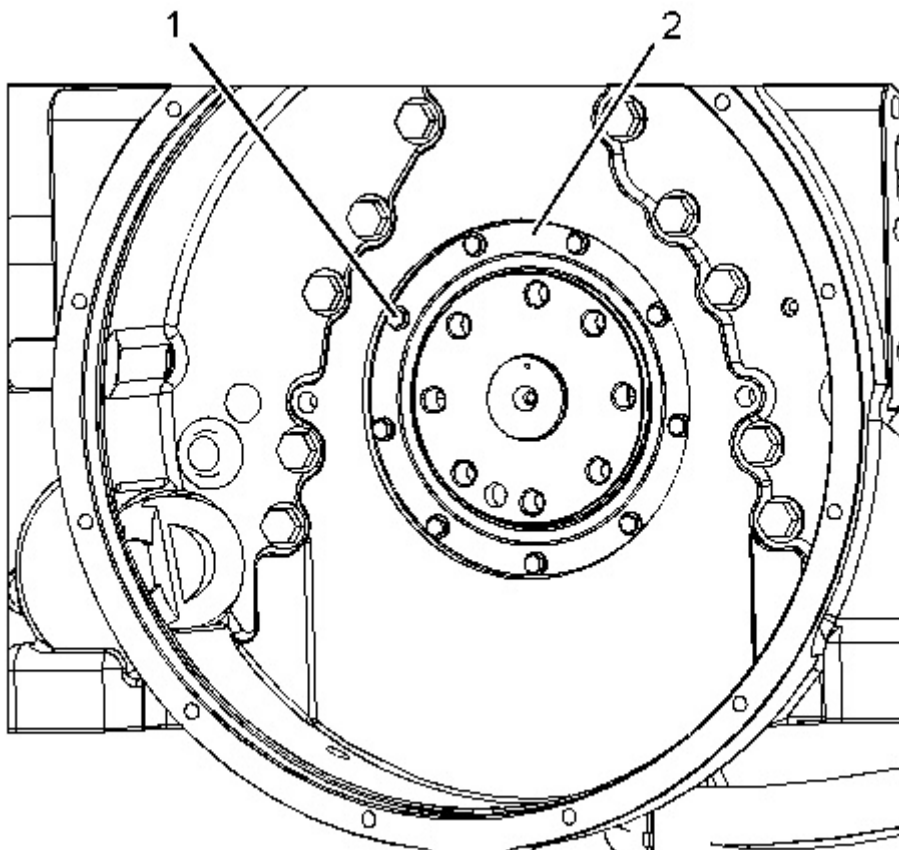

1. Remove bolts (1).
2. Remove crankshaft rear seal (2) and the O-ring seal.

**Note:** Refer to Reuse and Salvage Guidelines, SEBF8039, "Crankshaft Visual Inspection and Magnetic Particle Inspection" for the correct inspection procedure of the crankshaft seal surface.

**Note:** Refer to Reuse and Salvage Guidelines, SEBF9217, "Specifications for Crankshafts C7, C9, C-9, C10, C11, C12, C-12, C13, C-13, C15, C-15, C18, C-18, C27, C30, and C32 Engines" or the correct specifications of the crankshaft.

## Installation Procedure

Table 1

Required Tools			
Tool	Part Number	Part Description	Qty
A	-	Loctite 7649 Primer N	-
B	-	Loctite 620 Retaining Compound	-
C	147-2675	Wear Sleeve Installer	1

**Note:** Leave the shipping sleeve in place in order to install the crankshaft rear seal. The crankshaft rear seal must be installed dry.

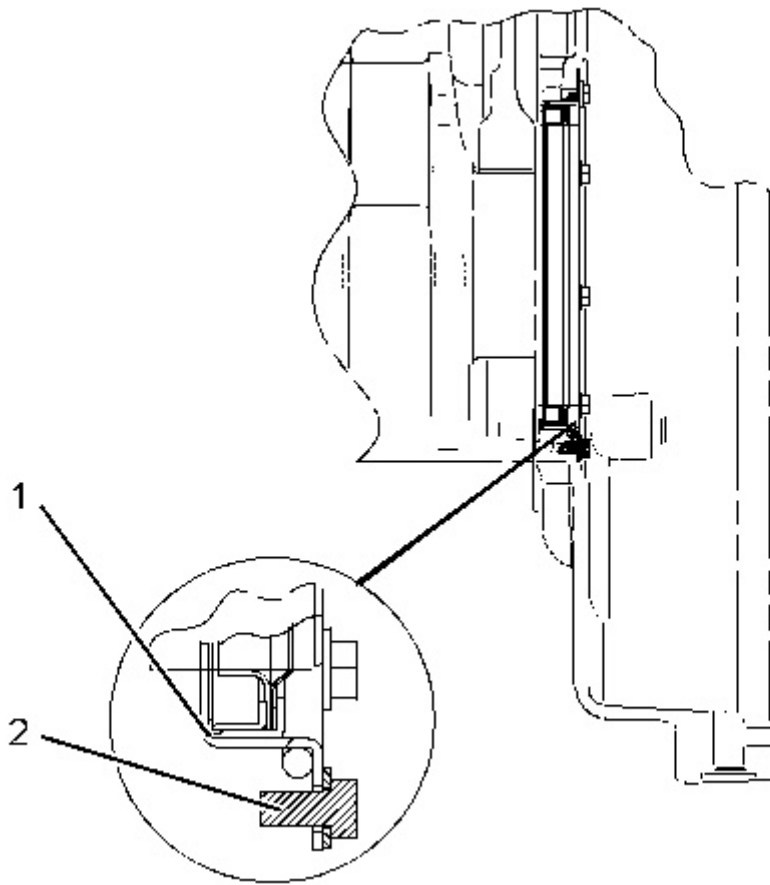

Illustration 2

g01140085

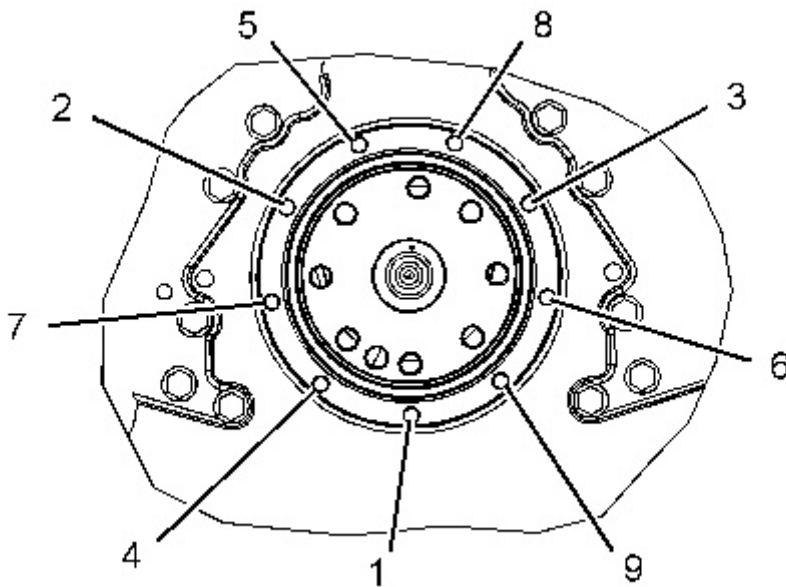

Illustration 3

g03698745

Numerical tightening sequence for bolts (2).

**Note:** If required, install a crankshaft wear sleeve at engine overhaul. For more information please refer to the following Reuse and Salvage Guidelines. Refer to Reuse and Salvage

Guidelines, SEBF9217, "Specifications for Crankshafts C7, C9, C-9, C10, C11, C12, C-12, C13, C-13, C15, C-15, C18, C-18, C27, C30, and C32 Engines" or the correct specifications of the crankshaft. Refer to Reuse and Salvage Guidelines, SEBF8039, "Crankshaft Visual Inspection and Magnetic Particle Inspection" for the correct inspection procedure of the crankshaft seal surface.

1. If a crankshaft wear sleeve is necessary, refer to Step 1.a through Step 1.d to install the crankshaft wear sleeve. If a crankshaft wear sleeve is not necessary, refer to Step 2.
  - a. Clean and polish the crankshaft of imperfections.
  - b. Use Tooling (A) to clean the outside diameter of the crankshaft and the inside diameter of the crankshaft wear sleeve.
  - c. Apply Tooling (B) to the outside diameter of the crankshaft and the inside diameter of the crankshaft wear sleeve.
  - d. Use Tooling (C) to install the crankshaft wear sleeve.

**Note:** Leave the shipping sleeve in place to install the crankshaft rear seal. The crankshaft rear seal must be installed dry.

**Note:** If the seal group, O-ring seal, and the shipping sleeve are separated, these components should not be used.

2. Lubricate the O-ring seal with clean engine oil that is on the back of the crankshaft rear seal (1).
3. Position crankshaft rear seal (1) and the shipping sleeve over the crankshaft. Push crankshaft rear seal (1) in place to dislodge the shipping sleeve.

**Note:** Do not remove the shipping sleeve until bolts (2) are installed.

4. Install new bolts (2) hand tight. Then, tighten bolts (2) in numerical sequence, shown in Illustration 3. Tighten bolts (2) to a torque of  $12 \pm 3 \text{ N}\cdot\text{m}$  ( $106 \pm 27 \text{ lb in}$ ).

**End By:**

- a. Install the flywheel. Refer to Disassembly and Assembly, "Flywheel - Install".
-

Product: INDUSTRIAL ENGINE  
Model: C13 INDUSTRIAL ENGINE RRA  
Configuration: C13 Industrial Engine RRA00001-UP

## Disassembly and Assembly C13 Engine and C13 Industrial Engine

Media Number -KENR8165-03

Publication Date -01/11/2017

Date Updated -14/11/2017

i02249340

# Flywheel Housing - Remove and Install

SMCS - 1157-010

S/N - PDJ1-UP

S/N - RRA1-UP

## Removal Procedure

### Start By:

- a. Remove the electric starting motor. Refer to Disassembly and Assembly, "Electric Starting Motor - Remove and Install".
- b. Remove the flywheel. Refer to Disassembly and Assembly, "Flywheel - Remove".
1. Support the engine.

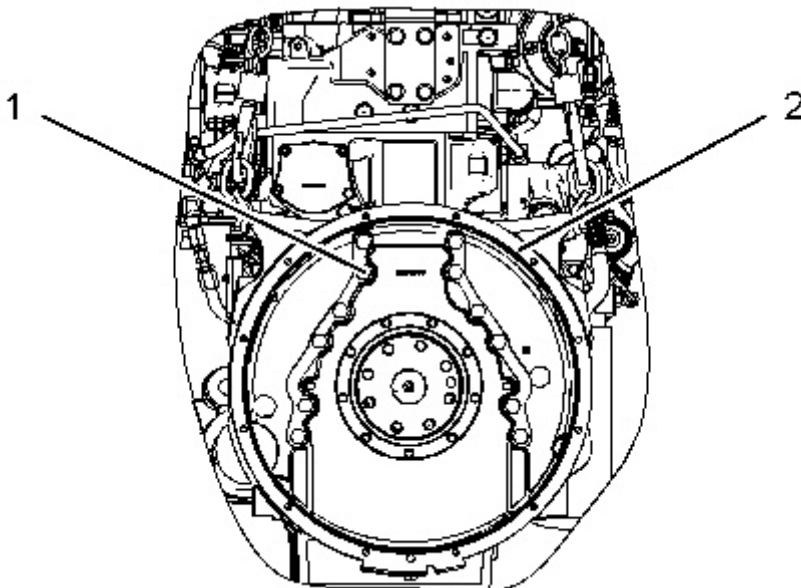

2. Attach a suitable lifting device to flywheel housing (2). The weight of flywheel housing (2) is approximately 62 kg (137 lb).
3. Remove bolts (1) and flywheel housing (2).

## Installation Procedure

Table 1

Required Tools			
Tool	Part Number	Part Description	Qty
A	1U-8846	Gasket Sealant	1

1. Apply Tooling (A) to the face of the cylinder block.

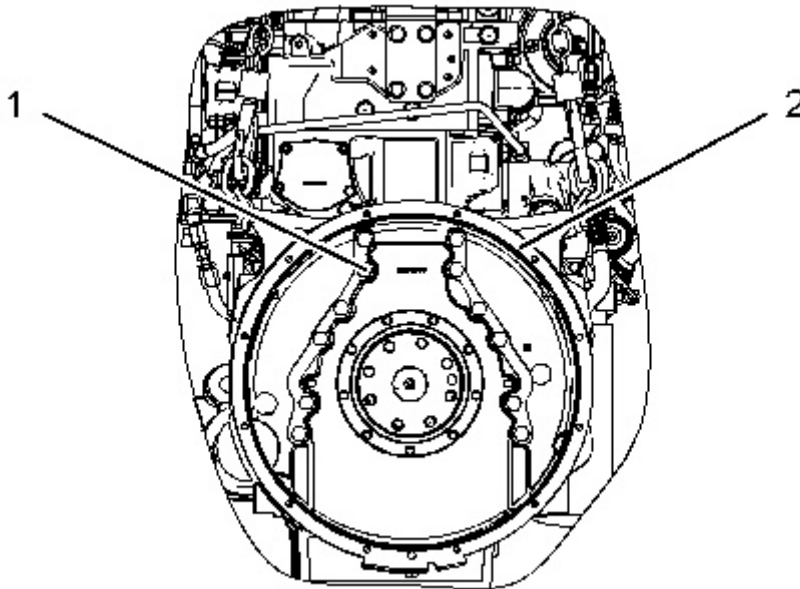

2. Attach a suitable lifting device to flywheel housing (2). The weight of flywheel housing (2) is approximately 62 kg (137 lb). Position flywheel housing (2) on the rear of the cylinder block.
3. Install bolts (1).

### End By:

- a. Install the flywheel. Refer to Disassembly and Assembly, "Flywheel - Install".
- b. Install the electric starting motor. Refer to Disassembly and Assembly, "Electric Starting Motor - Remove and Install".

Product: INDUSTRIAL ENGINE  
Model: C13 INDUSTRIAL ENGINE RRA  
Configuration: C13 Industrial Engine RRA00001-UP

## Disassembly and Assembly C13 Engine and C13 Industrial Engine

Media Number -KENR8165-03

Publication Date -01/11/2017

Date Updated -14/11/2017

i03542391

# Flywheel Housing - Remove and Install

SMCS - 1157-010

## Removal Procedure

Table 1

Required Tools			
Tool	Part Number	Part Description	Qty
A	138-7574	Link Brackets	2
B	8C-8422	Sealant	-

### Start By:

- a. Remove the flywheel.
- b. Remove the crankshaft rear seal.

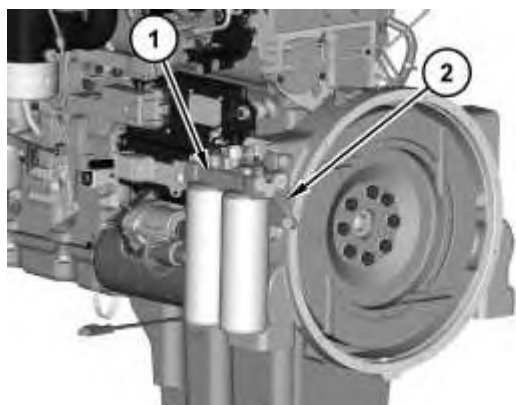

1. Remove fuel filter base (1) and reposition fuel filter base (1). Remove bracket (2).
- 

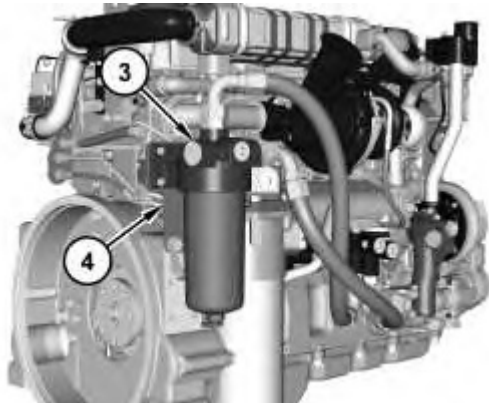

Illustration 2

g01870417

2. Remove oil filter base (3) and reposition oil filter base (3). Remove bracket (4).
- 

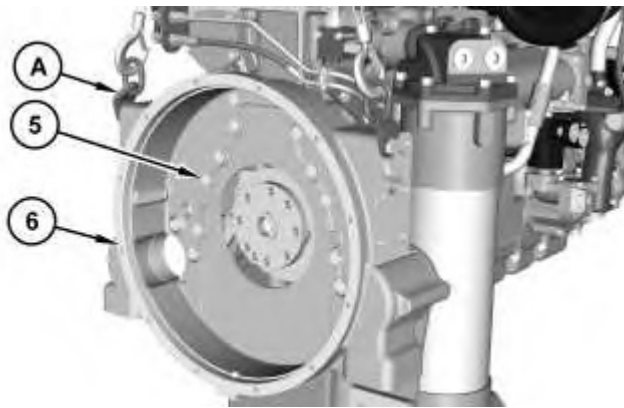

Illustration 3

g01870418

3. Install Tooling (A) and a suitable lifting device to flywheel housing (6). The weight of flywheel housing (6) is approximately 64 kg (140 lb). Remove bolts (5) and flywheel housing (6).

## Installation Procedure

1. Install flywheel housing (6) in reverse order of removal.
    - a. Apply Tooling (B) to flywheel housing (6).
-



Product: INDUSTRIAL ENGINE  
Model: C13 INDUSTRIAL ENGINE RRA  
Configuration: C13 Industrial Engine RRA00001-UP

## Disassembly and Assembly C13 Engine and C13 Industrial Engine

Media Number -KENR8165-03

Publication Date -01/11/2017

Date Updated -14/11/2017

i02285990

# Vibration Damper and Pulley - Remove and Install

SMCS - 1205-010

S/N - PDJ1-UP

S/N - RRA1-UP

## Removal Procedure

1. Remove the belt from the engine.

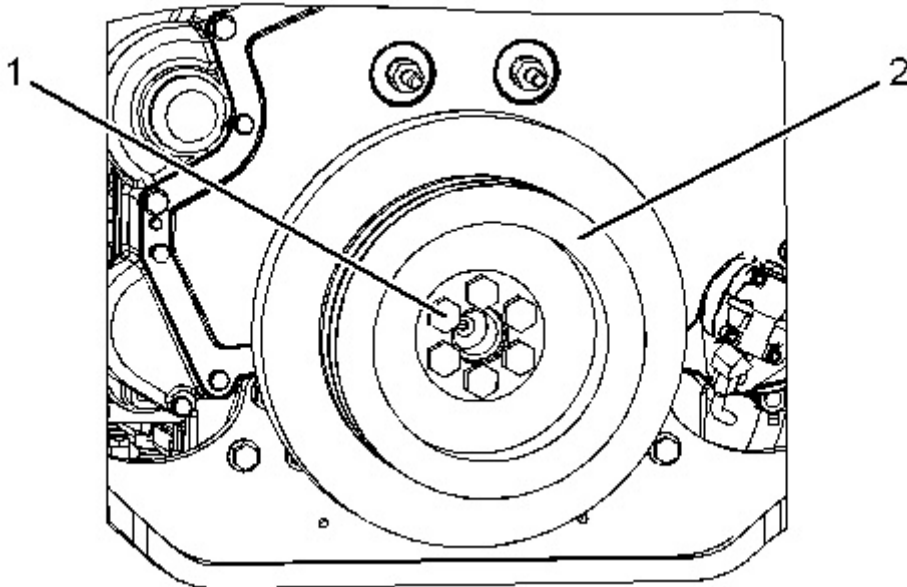

Illustration 1

g01144194

2. Attach a suitable lifting device to crankshaft vibration damper and pulley (2). The weight of crankshaft vibration damper and pulley (2) is approximately 27 kg (60 lb). Remove bolts (1).

3. Remove crankshaft vibration damper and pulley (2).

## Installation Procedure

---

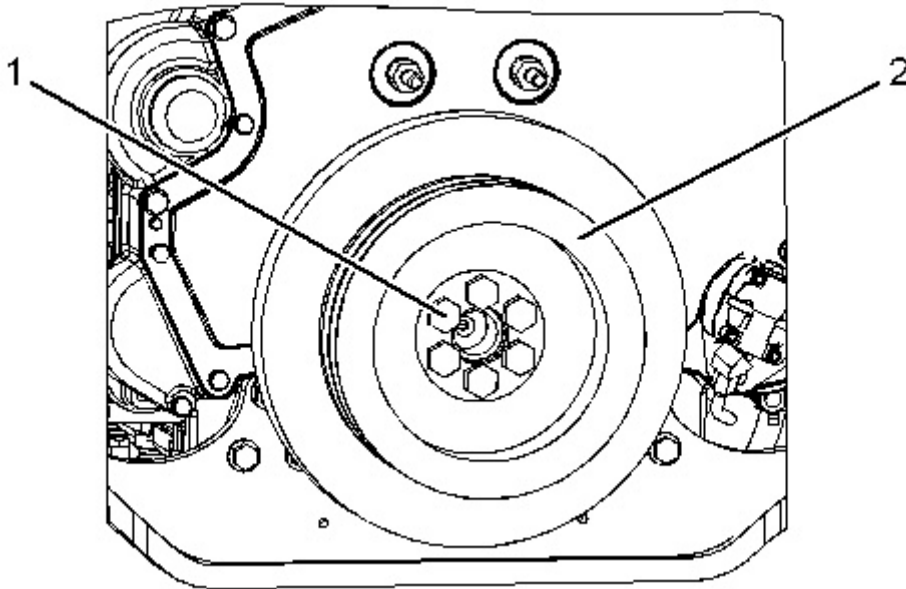

Illustration 2

g01144194

1. Attach a suitable lifting device to crankshaft vibration damper and pulley (2). The weight of crankshaft vibration damper and pulley (2) is approximately 27 kg (60 lb). Position crankshaft vibration damper and pulley (2) on the engine.
  2. Install bolts (1).
  3. Install the belt on the engine.
-

Product: INDUSTRIAL ENGINE  
Model: C13 INDUSTRIAL ENGINE RRA  
Configuration: C13 Industrial Engine RRA00001-UP

## Disassembly and Assembly C13 Engine and C13 Industrial Engine

Media Number -KENR8165-03

Publication Date -01/11/2017

Date Updated -14/11/2017

i03542628

# Vibration Damper and Pulley - Remove and Install

SMCS - 1205-010

## Removal Procedure

Table 1

Required Tools			
Tool	Part Number	Part Description	Qty
A	8T-0514	Guide Stud	1

1. Remove the belt. Refer to Operation and Maintenance Manual, "Belt - Inspect/Adjust/Replace".

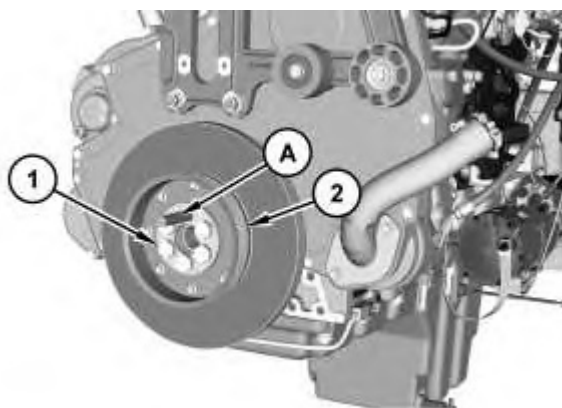
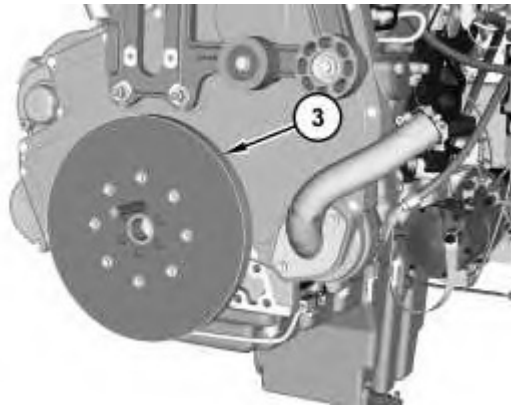

Illustration 1

g01870577

2. Remove one of bolts (1). Install Tooling (A). Remove remaining bolts (1) and pulley assembly (2).



---

Illustration 2

g01870580

3. Remove vibration damper (3).

## **Installation Procedure**

1. Install vibration damper (3) and pulley assembly (2) in reverse order of removal.
-

Product: INDUSTRIAL ENGINE  
Model: C13 INDUSTRIAL ENGINE RRA  
Configuration: C13 Industrial Engine RRA00001-UP

## Disassembly and Assembly C13 Engine and C13 Industrial Engine

Media Number -KENR8165-03

Publication Date -01/11/2017

Date Updated -14/11/2017

i03542724

# Crankshaft Front Seal - Remove and Install

SMCS - 1160-010

## Removal Procedure

### Start By:

- a. Remove the vibration damper and the pulley.

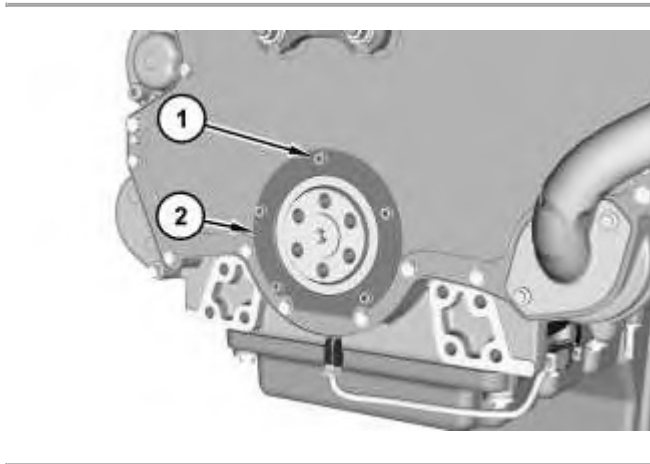

Illustration 1

g01870637

1. Remove nuts (1) and crankshaft front seal (2).

## Installation Procedure

**Note:** Leave the shipping sleeve in place in order to install the crankshaft front seal. The crankshaft front seal must be installed dry.

1. Install crankshaft front seal (2) in reverse order of removal.
-

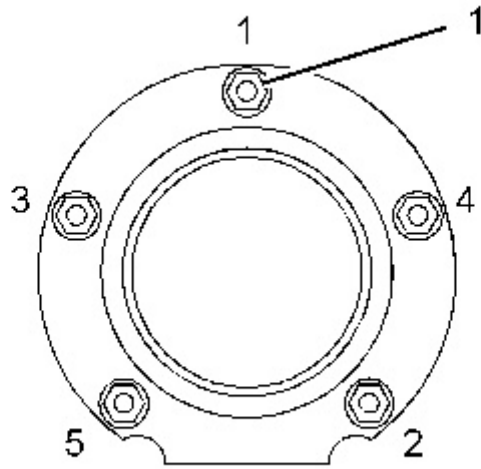

---

Illustration 2

g01870695

- a. Tighten nuts (1) in a numerical sequence.
-

Product: INDUSTRIAL ENGINE  
Model: C13 INDUSTRIAL ENGINE RRA  
Configuration: C13 Industrial Engine RRA00001-UP

## Disassembly and Assembly C13 Engine and C13 Industrial Engine

Media Number -KENR8165-03

Publication Date -01/11/2017

Date Updated -14/11/2017

i03544761

# Front Cover - Remove and Install

SMCS - 1166-010

## Removal Procedure

### Start By:

- a. Remove the accessory drive.
- b. Remove the vibration damper and the pulley.

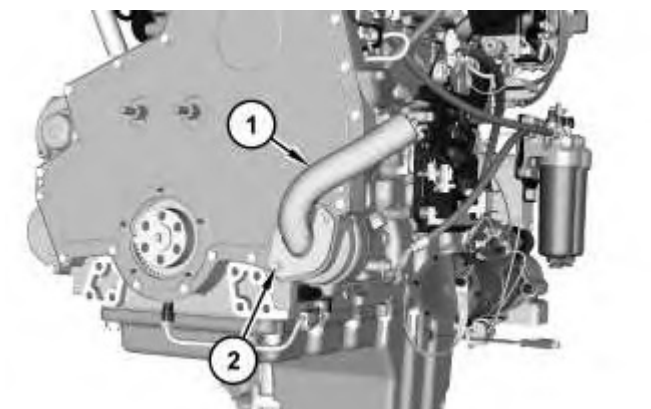

---

Illustration 1

g01872516

1. Remove bolts (2), tube assembly (1), and the O-ring seal.
-

Thank you so much for reading.  
Please click the “Buy Now!”  
button below to download the  
complete manual.



After you pay.

You can download the most  
perfect and complete manual in  
the world immediately.

Our support email:

[ebooklibonline@outlook.com](mailto:ebooklibonline@outlook.com)