

Product: INDUSTRIAL ENGINE
Model: C15 INDUSTRIAL ENGINE MCW
Configuration: C15 Industrial Engine MCW00001-UP

Disassembly and Assembly C15 and C18 Industrial Engines

Media Number -REN8630-07

Publication Date -01/11/2017

Date Updated -15/11/2017

i02187181

Power Take-Off Drive Group - Assemble

SMCS - 1165-016

S/N - GJE1-UP

S/N - JDA1-UP

S/N - JKG1-UP

S/N - JRE1-UP

S/N - MCW1-UP

S/N - PBN1-UP

S/N - PCZ1-UP

S/N - PDM1-UP

S/N - WJH1-UP

S/N - WRH1-UP

Assembly Procedure

Table 1

Required Tools			
Tool	Part Number	Part Description	Qty
A	-	Guide Stud (5/8 - 18 x 8 inch)	2
B	1P-0520	Driver Group	2

NOTICE

Keep all parts clean from contaminants.

Contaminants may cause rapid wear and shortened component life.

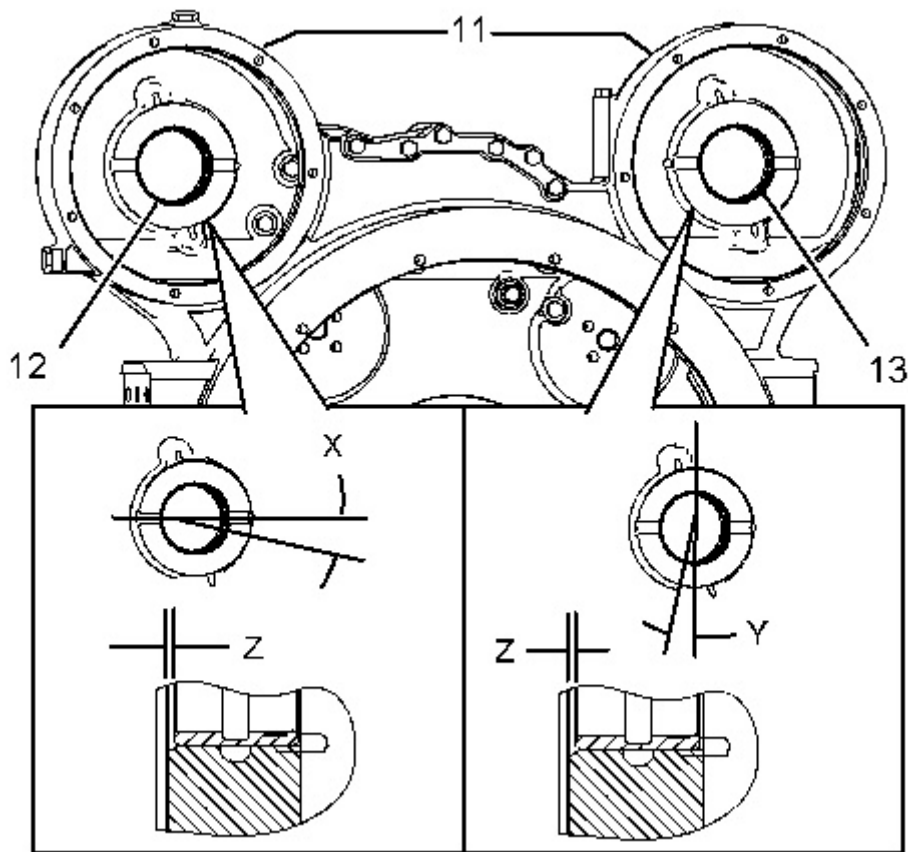

Illustration 1

g01106888

1. Install sleeve bearing (13) in the flywheel housing with Tooling (B). The split in the sleeve bearing should be located at Angle (Y), which is 15 ± 1 degrees from the horizontal centerline. The bearing should be installed to Depth (Z), which is 2.0 ± 0.5 mm (0.08 ± 0.02 inch).
 2. Install sleeve bearing (12) in the flywheel housing with Tooling (B). The split in the sleeve bearing should be located at Angle (X), which is 15 ± 1 degrees from the vertical centerline. The bearing should be installed to Depth (Z), which is 2.0 ± 0.5 mm (0.08 ± 0.02 inch).
 3. Install the O-ring seal on cover (11). Install cover (11) and the bolts on the back side of the flywheel housing.
-

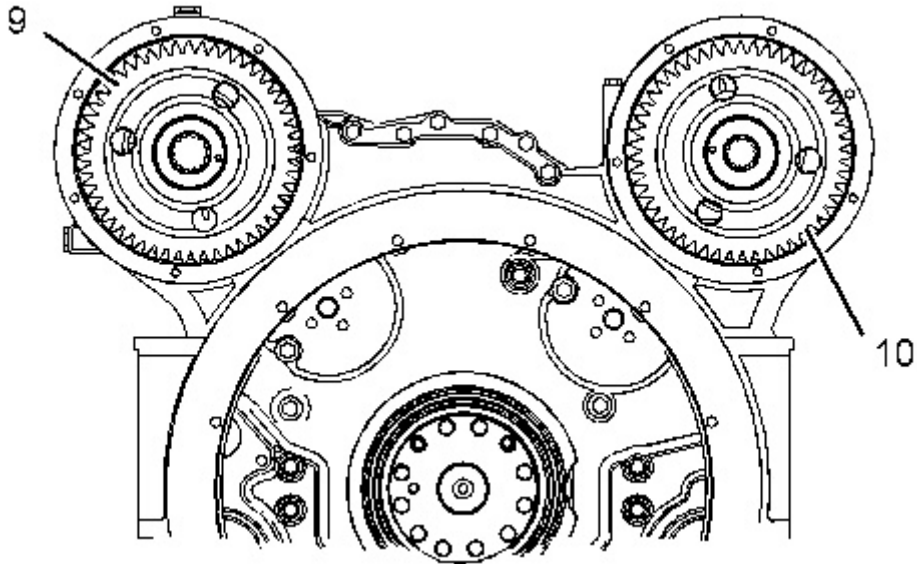

Illustration 2

g01106649

4. Position gear assembly (9) and gear assembly (10) in the flywheel housing.
-

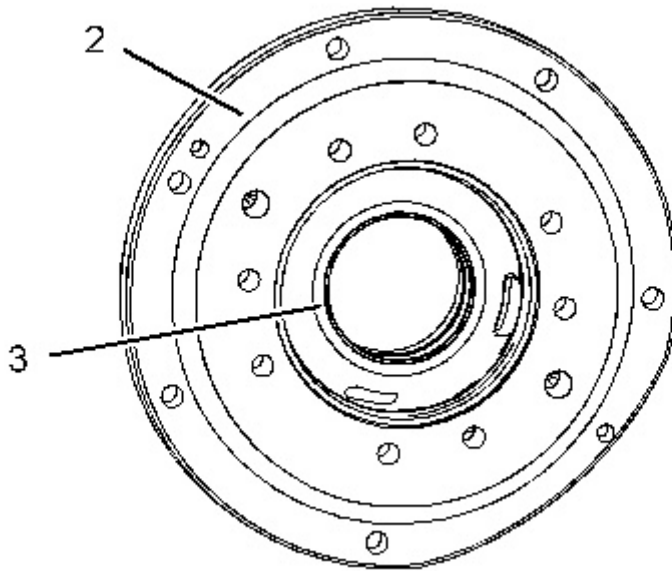

Illustration 3

g01106948

5. Use Tooling (B) and install sleeve bearing (3) in adapter (2). Install the O-ring seal on adapter (2).
-

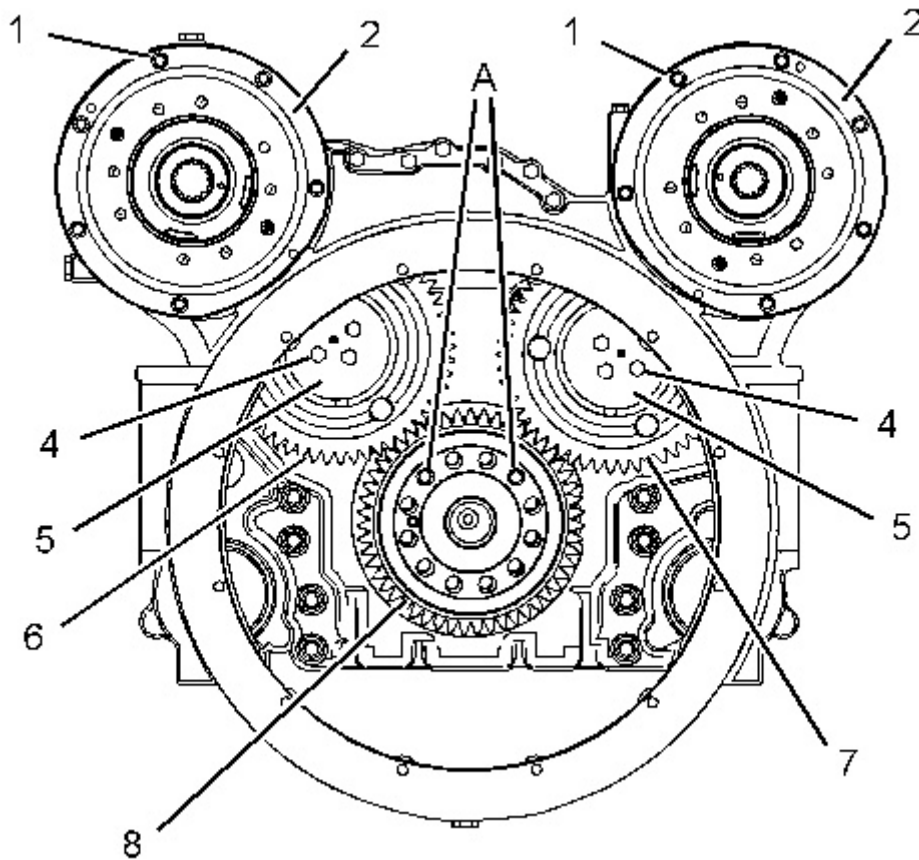

Illustration 4

g01106976

6. Align the relief groove in the sleeve bearing with the relief groove in the idler gear (6). Use Tooling (B) to install the sleeve bearing in idler gear (6).
7. Position idler gear (6) and retainer (5). Install bolts (4).
8. Align the relief groove in the sleeve bearing with the relief groove in the idler gear (7). Use Tooling (B) to install the sleeve bearing in idler gear (7).
9. Position idler gear (7) and retainer (5). Install bolts (4).
10. Install the O-ring seal in the counterbore of crankshaft gear (8). Lubricate the O-ring seal with clean engine oil. Install crankshaft gear (8) on Tooling (A).
11. Position adapter (2) on the flywheel housing. Apply Tooling (C) to the threads of bolts (1) and install the bolts.

End By:

- a. Install the flywheel. Refer to Disassembly and Assembly, "Flywheel - Install".

Product: INDUSTRIAL ENGINE
Model: C15 INDUSTRIAL ENGINE MCW
Configuration: C15 Industrial Engine MCW00001-UP

Disassembly and Assembly C15 and C18 Industrial Engines

Media Number -REN8630-07

Publication Date -01/11/2017

Date Updated -15/11/2017

i02193852

Vibration Damper and Pulley - Remove and Install

SMCS - 1205-010

Removal Procedure

Table 1

Required Tools			
Tool	Part Number	Part Description	Qty
A	-	Guide Stud (5/8 - 18 x 9 inch)	2

NOTICE

Keep all parts clean from contaminants.

Contaminants may cause rapid wear and shortened component life.

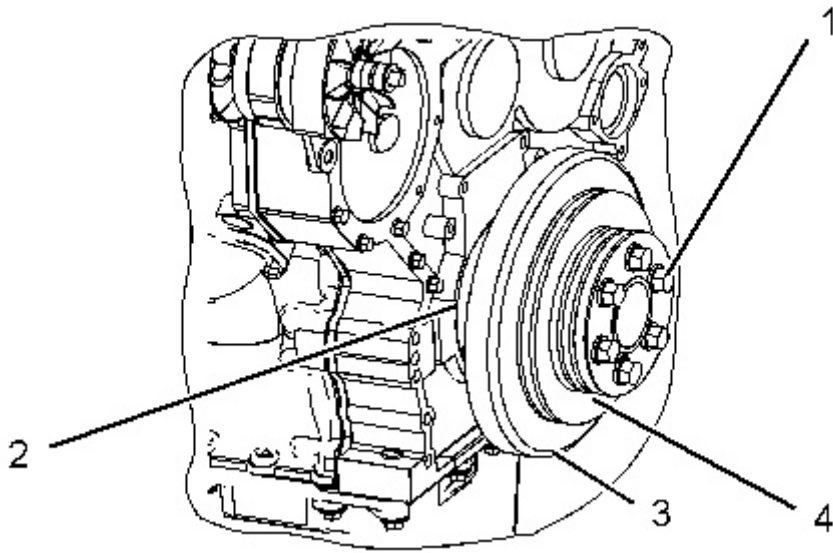

Illustration 1

g01058649

1. Remove two bolts (1). Install Tooling (A).
2. Remove remaining bolts (1). Remove pulley (4).
3. Remove vibration damper (3).
4. Remove adapter (2) from the crankshaft.
5. Remove Tooling (A) from the crankshaft.

Installation Procedure

Table 2

Required Tools			
Tool	Part Number	Part Description	Qty
A	-	Guide Stud (5/8 - 18 x 9 inch)	2
B	4C-5593	Anti-Seize Compound	-

NOTICE

Keep all parts clean from contaminants.

Contaminants may cause rapid wear and shortened component life.

NOTICE

Thoroughly inspect the viscous damper for signs of leakage or for signs of a dented (damaged) case. Either of these conditions can cause the weight to make contact with the case. This can affect the viscous damper's operation.

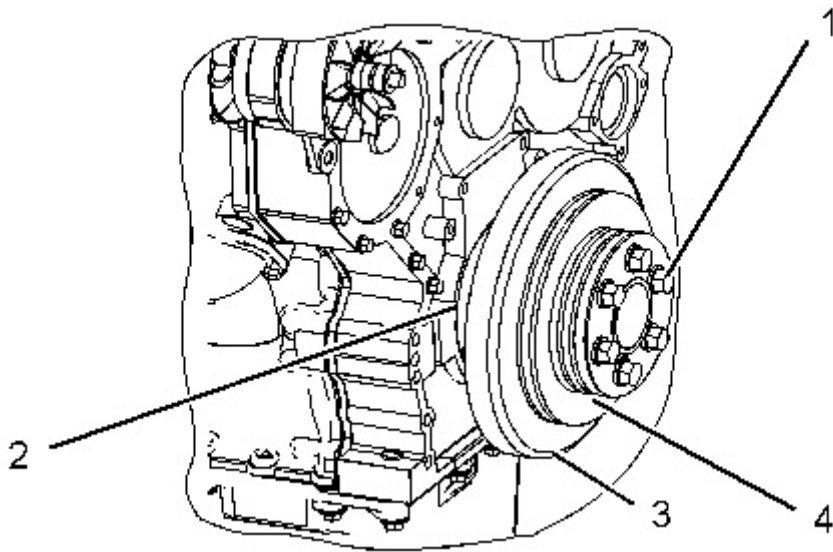

Illustration 2

g01058649

1. Install Tooling (A) in the crankshaft.
 2. Install adapter (2) on Tooling (A).
 3. Install vibration damper (3) on Tooling (A).
 4. Install pulley (4) on Tooling (A).
 5. Apply Tooling (B) to bolts (1).
 6. Remove Tooling (A) and install the remaining bolts.
-

Product: INDUSTRIAL ENGINE
Model: C15 INDUSTRIAL ENGINE MCW
Configuration: C15 Industrial Engine MCW00001-UP

Disassembly and Assembly C15 and C18 Industrial Engines

Media Number -REN8630-07

Publication Date -01/11/2017

Date Updated -15/11/2017

i03190521

Crankshaft Front Seal - Remove

SMCS - 1160-011

Removal Procedure

Table 1

Required Tools			
Tool	Part Number	Part Description	Qty
A	1U-7600	Slide Hammer Puller	1
B	-	Pry Bar	1
C	5P-7318	Wear Sleeve Distorter Group	1

Start By:

- a. Remove the vibration damper and the pulley. Refer to Disassembly and Assembly, "Vibration Damper and Pulley - Remove and Install".

NOTICE

Keep all parts clean from contaminants.

Contaminants may cause rapid wear and shortened component life.

Note: The crankshaft front seal and the wear sleeve must be replaced at the same time. Once the crankshaft front seal and the wear sleeve are separated, these components can not be used again.

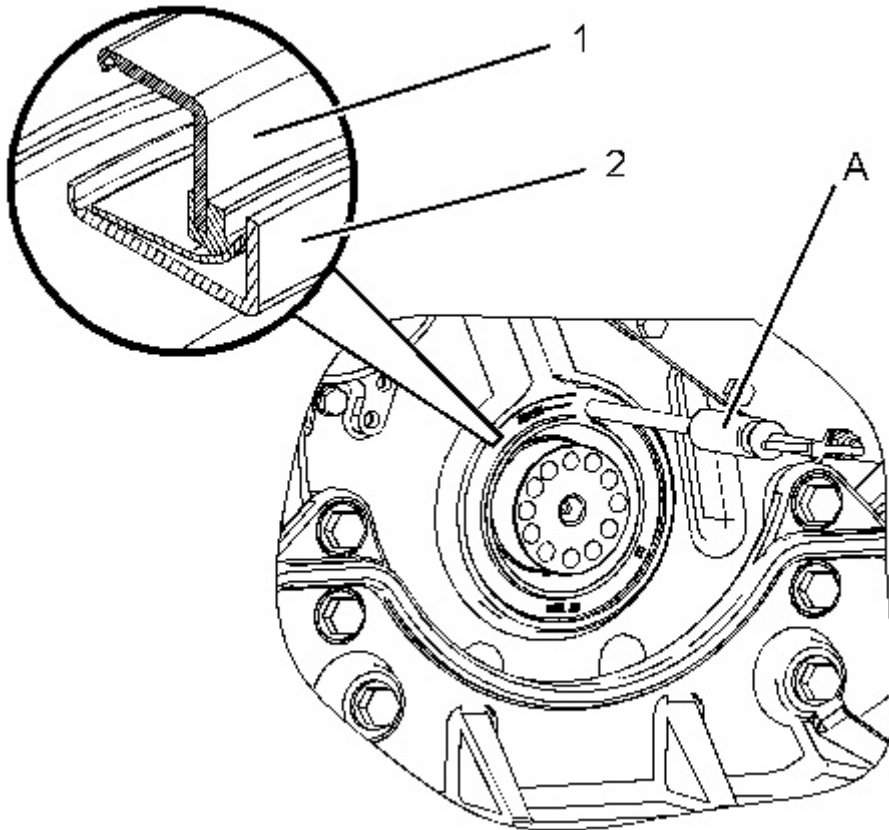

Illustration 1

g01044861

Note: Ensure that you do not damage the front housing with Tooling (B).

Note: If the wear sleeve starts to slide off the crankshaft, go to Step 2.

1. Use Tooling (B) to pry around the lip of wear sleeve (2).
 2. Use a small drill in order to puncture three or more holes in crankshaft front seal (1).
 3. Use Tooling (A) to remove crankshaft front seal (1).
 4. If necessary, use Tooling (C) to remove wear sleeve (2).
-

Product: INDUSTRIAL ENGINE
Model: C15 INDUSTRIAL ENGINE MCW
Configuration: C15 Industrial Engine MCW00001-UP

Disassembly and Assembly C15 and C18 Industrial Engines

Media Number -REN8630-07

Publication Date -01/11/2017

Date Updated -15/11/2017

i03203779

Crankshaft Front Seal - Install

SMCS - 1160-012

Installation Procedure

Table 1

Required Tools			
Tool	Part Number	Part Description	Qty
D	5P-1733	Seal Locator	1
E	5P-1737	Bolt	3
F	9S-8858	Nut (Seal Installer)	1
G	6V-6142	Seal Installer	1

NOTICE

Keep all parts clean from contaminants.

Contaminants may cause rapid wear and shortened component life.

Note: The crankshaft front seal and the wear sleeve must be replaced at the same time. Once the crankshaft front seal and the wear sleeve are separated, these components cannot be used again.

Note: Do not use any type of lubricant during the installation of the crankshaft front seal and the wear sleeve.

1. Before installation of the crankshaft front seal and the wear sleeve, inspect the crankshaft for scratches. Also, inspect the crankshaft for any distortion on the surface that may lead to

an out of round condition. Use a polishing cloth in order to remove any imperfections on the crankshaft.

2. Clean the outside diameter of the crankshaft.

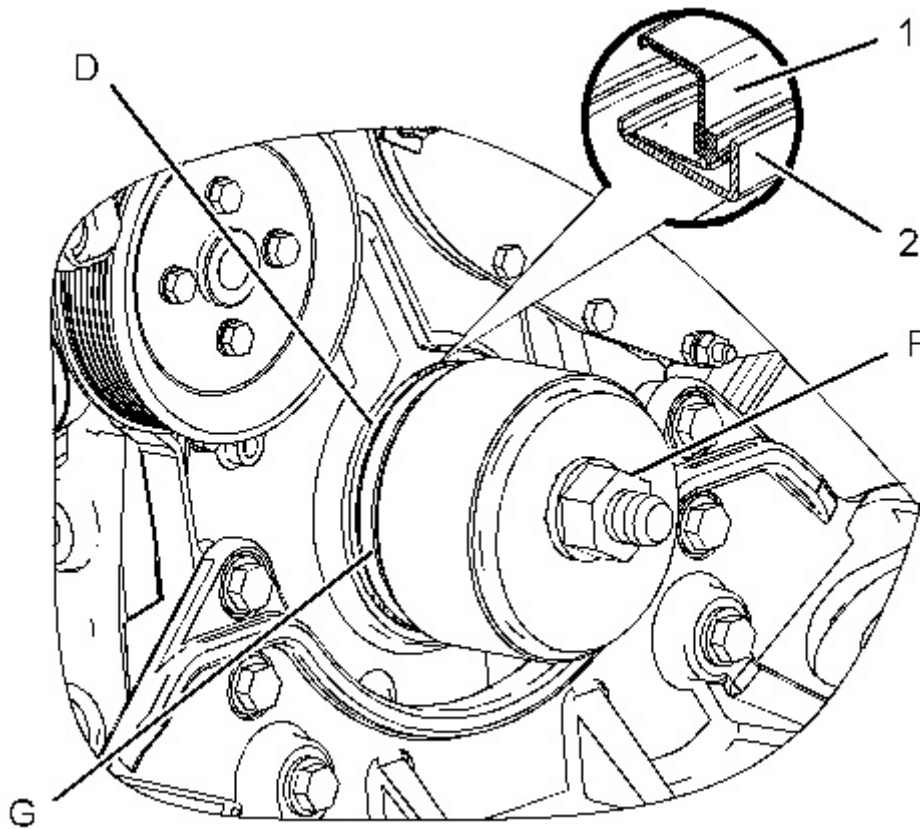

Illustration 1

g01635160

3. Fasten Tooling (D) to the crankshaft with Tooling (E).

Note: Install the crankshaft front seal with the arrow that shows the direction of crankshaft rotation toward the front of the engine.

4. Position wear sleeve (2) and crankshaft front seal (1) on Tooling (D). Install Tooling (G) on Tooling (D). Lubricate the face of the washer on Tooling (F). Install Tooling (F) on Tooling (D).
5. Tighten Tooling (F) until Tooling (G) contacts Tooling (D).
6. Remove Tooling (F) and Tooling (G) from Tooling (D).
7. Remove Tooling (E) and Tooling (D) from the crankshaft.

End By:

- a. Install the vibration damper and the pulley. Refer to Disassembly and Assembly, "Vibration Damper and Pulley - Remove and Install".
-

Product: INDUSTRIAL ENGINE
Model: C15 INDUSTRIAL ENGINE MCW
Configuration: C15 Industrial Engine MCW00001-UP

Disassembly and Assembly C15 and C18 Industrial Engines

Media Number -REN8630-07

Publication Date -01/11/2017

Date Updated -15/11/2017

i04275771

Front Cover - Remove

SMCS - 1166-011

Removal Procedure

NOTICE

Keep all parts clean from contaminants.

Contaminants may cause rapid wear and shortened component life.

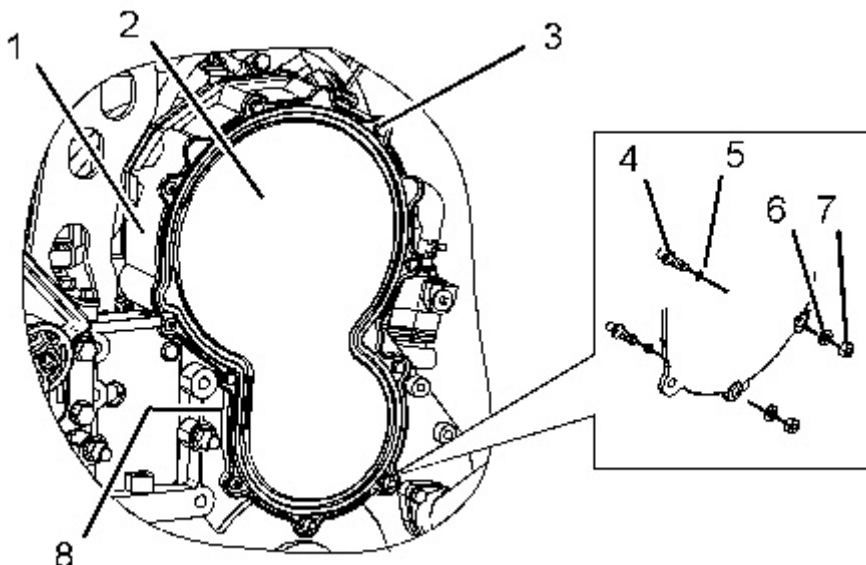

1. Remove button head screws (3).
 2. Remove nuts (7) and washers (6) from studs (4).
 3. Remove front cover (2) from front housing (1).
 4. Remove O-ring seal (5) from studs (4).
 5. Remove seal (8) from front cover (2).
-

Product: INDUSTRIAL ENGINE
Model: C15 INDUSTRIAL ENGINE MCW
Configuration: C15 Industrial Engine MCW00001-UP

Disassembly and Assembly C15 and C18 Industrial Engines

Media Number -REN8630-07

Publication Date -01/11/2017

Date Updated -15/11/2017

i04275789

Front Cover - Install

SMCS - 1166-012

Installation Procedure

Table 1

Required Tools			
Tool	Part Number	Part Description	Qty
A	155-0695	Thread Lock Compound	-

NOTICE

Keep all parts clean from contaminants.

Contaminants may cause rapid wear and shortened component life.

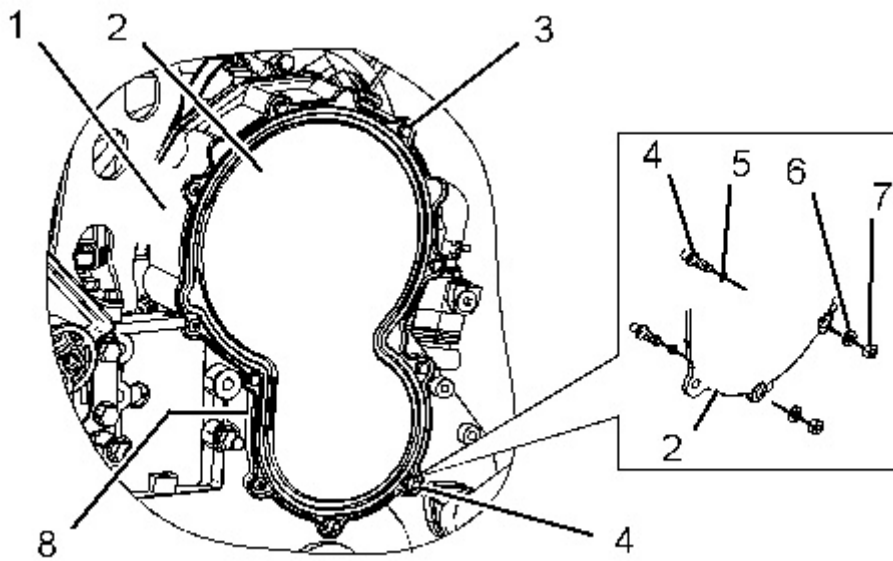

Illustration 1

g01268777

1. If studs (4) are loose or the threads are damaged, install new studs in front housing (1). Apply Tooling (A) to the threads of the studs. Install the studs in the front housing. Install O-ring seal (5) on the studs.
 2. Install seal (8) in front cover (2).
 3. Install front cover (2) on studs (4). Install washers (6) and nuts (7).
 4. Install button head screws (3). Tighten the button head screws to a torque of 21 ± 3 N·m (15 ± 2 lb ft).
-

Product: INDUSTRIAL ENGINE
Model: C15 INDUSTRIAL ENGINE MCW
Configuration: C15 Industrial Engine MCW00001-UP

Disassembly and Assembly C15 and C18 Industrial Engines

Media Number -REN8630-07

Publication Date -01/11/2017

Date Updated -15/11/2017

i02721549

Gear Group (Front) - Remove

SMCS - 1206-011

Removal Procedure

Table 1

Required Tools			
Tool	Part Number	Part Description	Qty
A	1P-0510	Driver Group	1

Start By:

- a. Remove the front housing. Refer to Disassembly and Assembly, "Housing (Front) - Remove".
- b. Remove the air compressor, if necessary. Refer to Disassembly and Assembly, "Air Compressor - Remove and Install".
- c. Remove the water pump, if necessary. Refer to Disassembly and Assembly, "Water Pump - Remove".
- d. Remove the auxiliary water pump, if necessary. Refer to Disassembly and Assembly, "Auxiliary Water Pump - Remove".
- e. Remove the fuel transfer pump, if necessary. Refer to Disassembly and Assembly, "Fuel Transfer Pump - Remove".

NOTICE

Keep all parts clean from contaminants.

Contaminants may cause rapid wear and shortened component life.

NOTICE

Do not turn the crankshaft or the camshaft while the camshaft gear is removed. If the front gear group is not correctly timed during installation, interference can occur between the pistons and the valves, resulting in damage to the engine.

Note: Be sure to mark the orientation of each of the gears for installation purposes.

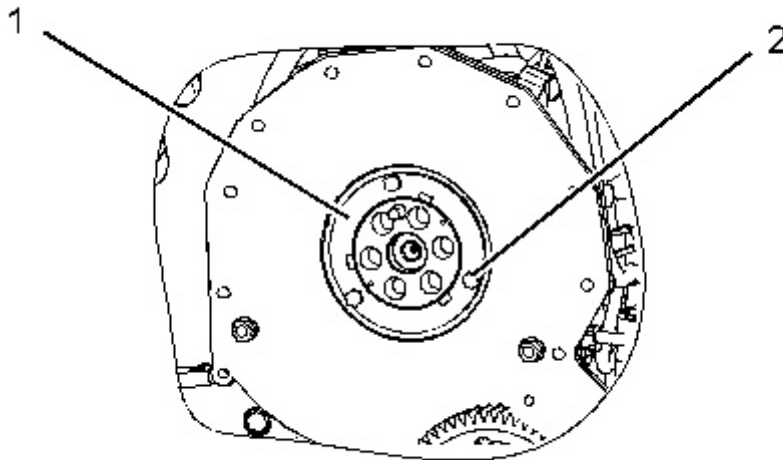

Illustration 1

g01008429

1. Remove bolts (2) and thrust plate (1).
-

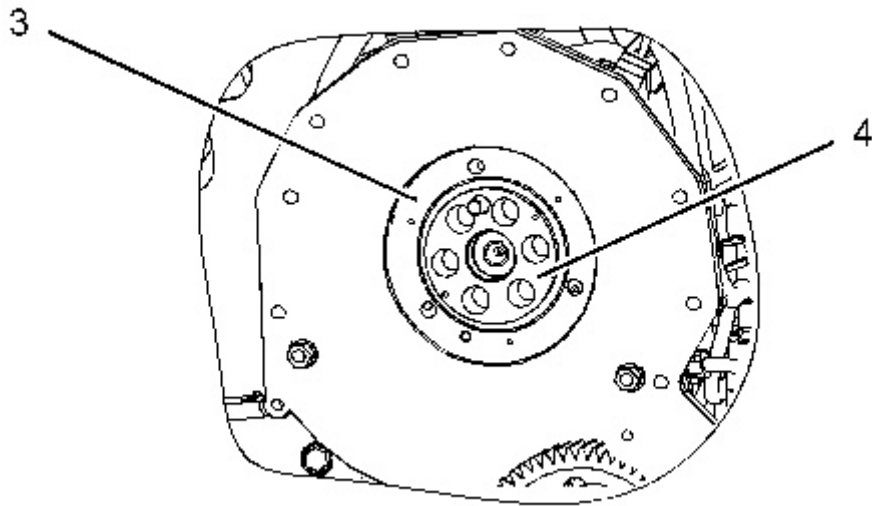

Illustration 2

g01008430

2. Remove sealing plate (3) and adapter (4).

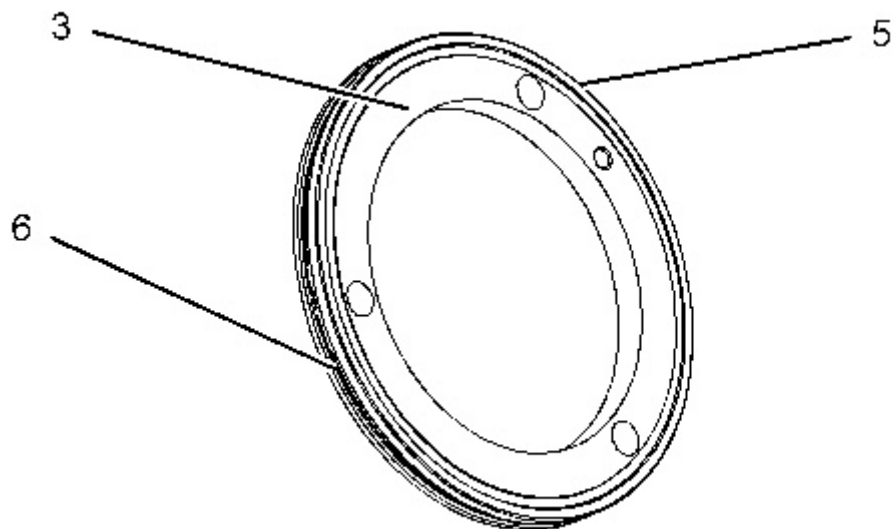

Illustration 3

g01008431

3. Remove O-ring seal (5) and O-ring seal (6) from sealing plate (3).

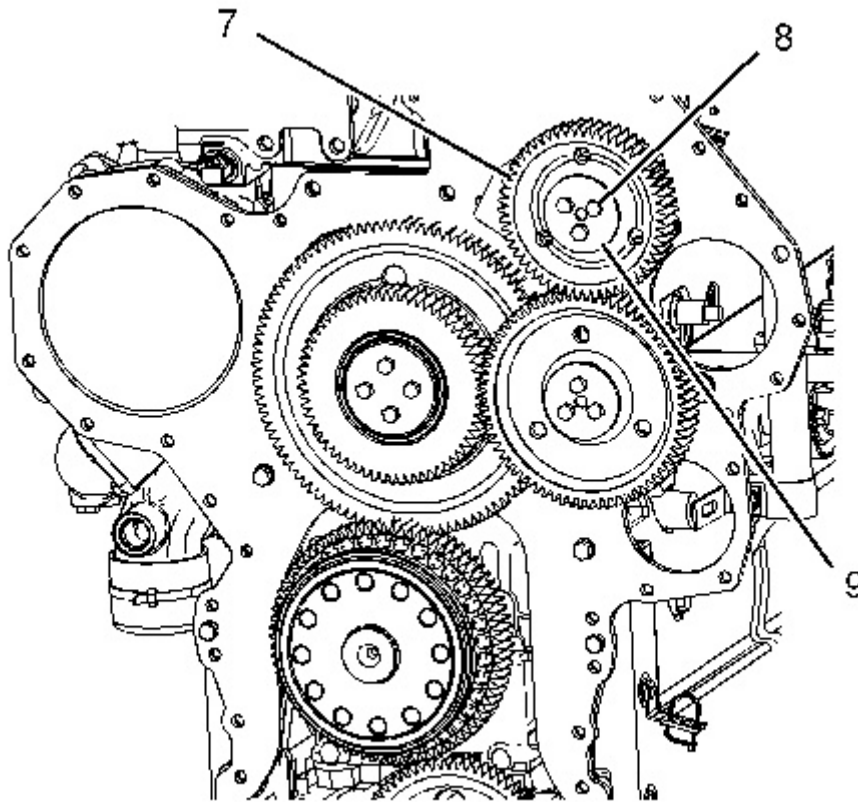

Illustration 4

g01101536

4. Remove bolts (8), plate (9), and adjustable idler gear assembly (7).
 5. Use Tooling (A) and remove the sleeve bearing from adjustable idler gear assembly (7).
-

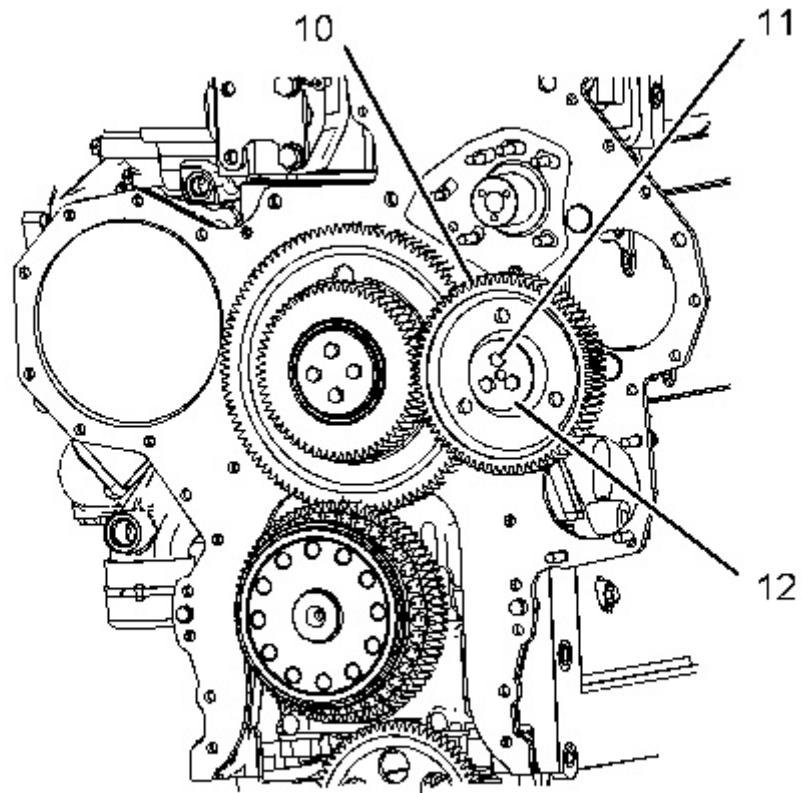

Illustration 5

g01101045

6. Remove bolts (11), plate (12), and idler gear assembly (10).
 7. Use Tooling (A) and remove the sleeve bearing from idler gear assembly (10).
-

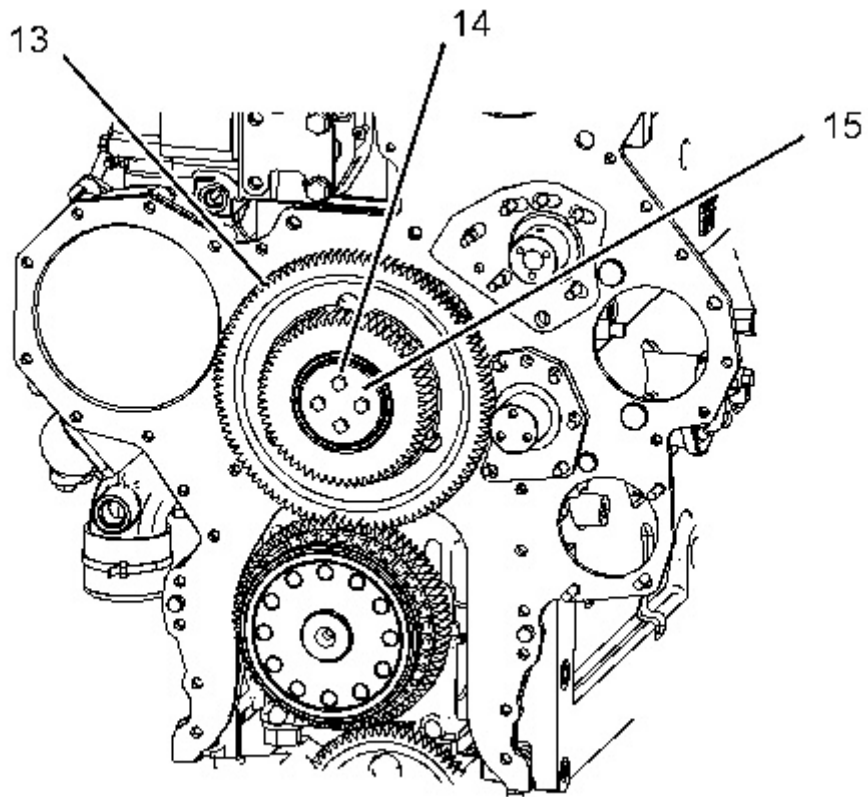

Illustration 6

g01101048

8. Remove bolts (14), plate (15), and cluster gear assembly (13).
 9. Use Tooling (A) and remove the sleeve bearing from cluster gear assembly (13).
-

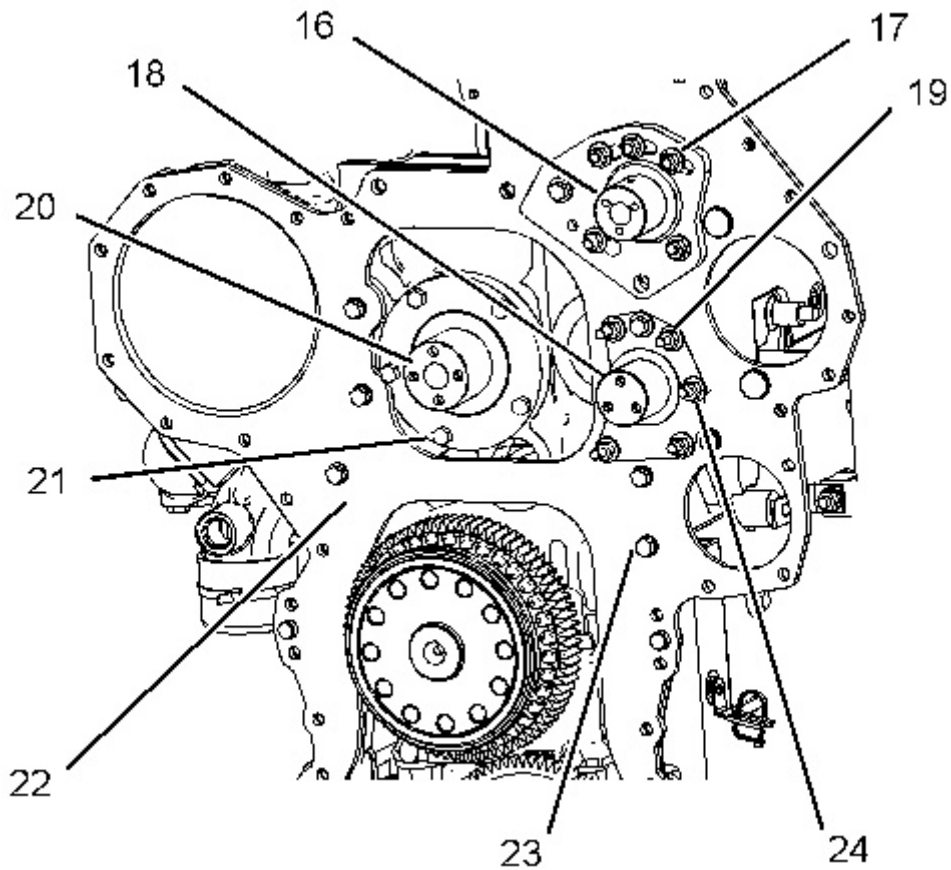

Illustration 7

g01101050

Note: Stub shaft assembly (16) must be removed in order to remove plate (22). The backlash for the camshaft gear and the adjustable idler gear assembly will need to be readjusted at assembly.

10. Remove nuts (17) and remove stub shaft assembly (16).

Note: Stub shaft (18) must be removed in order to remove plate (22).

11. Remove nuts (19) and remove stub shaft (18).
 12. Remove bolts (21) and remove stub shaft (20).
 13. Remove locking bolts (23) that hold plate (22) to the cylinder block. Remove plate (22).
 14. If studs (24) are loose or the threads are damaged, remove the studs from the front plate.
-

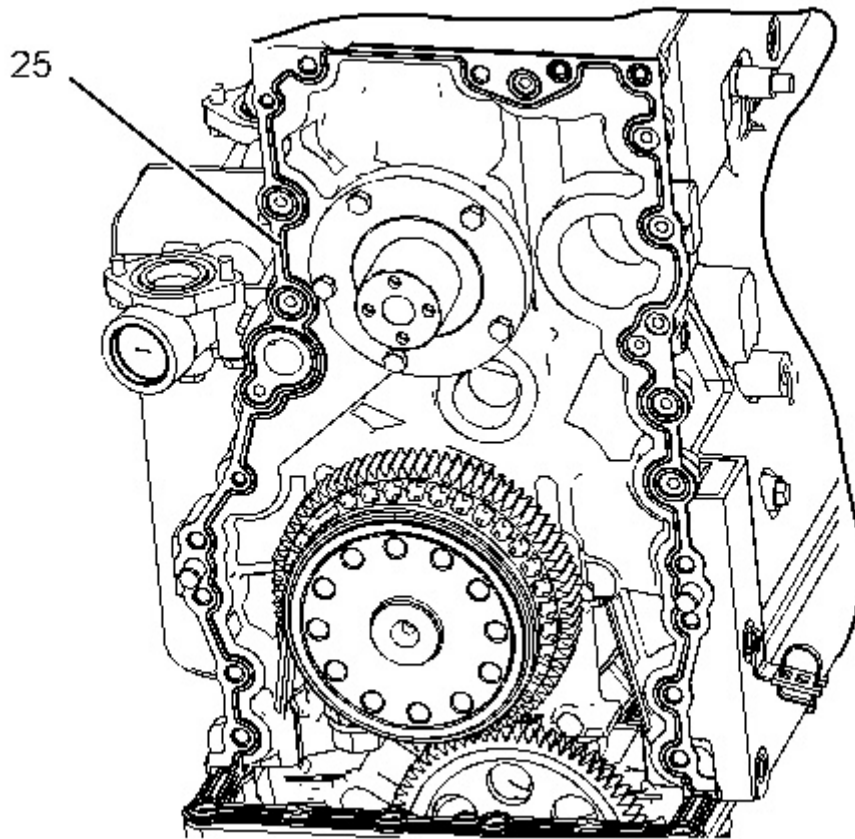

Illustration 8

g01101052

15. Remove integral seal (25) from the cylinder block.
-

Thank you so much for reading.
Please click the “Buy Now!”
button below to download the
complete manual.



After you pay.

You can download the most
perfect and complete manual in
the world immediately.

Our support email:

ebooklibonline@outlook.com