

Product: INDUSTRIAL ENGINE  
Model: C2.2 INDUSTRIAL ENGINE C6M  
Configuration: C2.2 Industrial Engine C6M00001-UP

## **Disassembly and Assembly C0.5, C0.7, C1.1, C1.5, C1.6 and and C2.2 Industrial Engines**

Media Number -KENR6229-05

Publication Date -01/03/2007

Date Updated -14/07/2017

i02602634

# **Exhaust Manifold - Remove and Install**

SMCS - 1059-010

## **Removal Procedure**

### **Start By:**

- a. If the engine is equipped with a turbocharger, remove the turbocharger. Refer to Disassembly and Assembly, " Turbocharger, Remove and Install".

---

### **NOTICE**

**Keep all parts clean from contaminants.**

**Contaminants may cause rapid wear and shortened component life.**

---

**Note:** The two cylinder, the three cylinder and the four cylinder engines have different exhaust manifolds. The removal procedure is similar for all models.

---

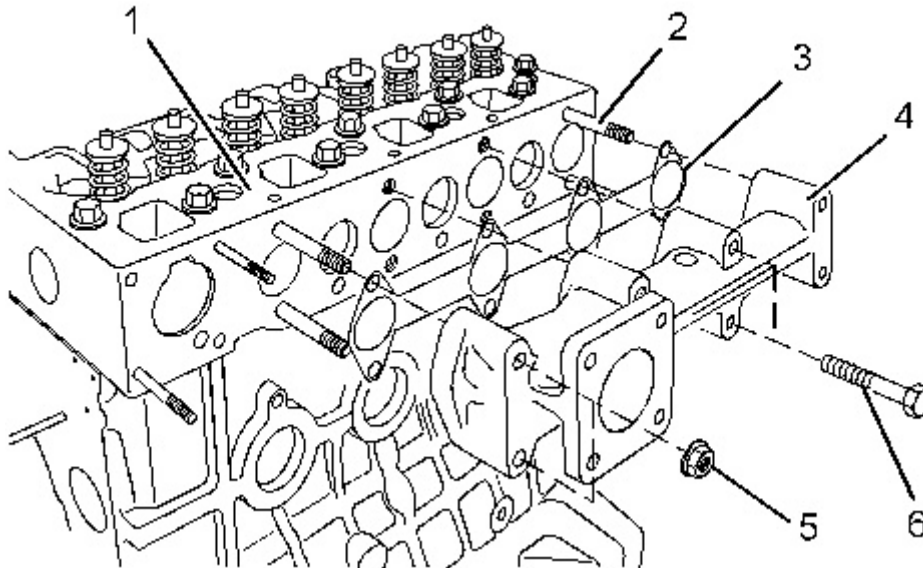

Illustration 1  
Typical example

g01326567

1. Loosen nuts (5) and bolts (6).

**Note:** In order to prevent distortion of the exhaust manifold, loosen the outer fasteners first.

2. Remove nuts (5) and bolts (6).

**Note:** Identify bolts of different lengths so that the bolts can be installed in the correct positions.

3. Remove exhaust manifold (4) from cylinder head (1). Note the orientation of the exhaust manifold for installation.
4. Remove gasket (3) from cylinder head (1).
5. If necessary, remove exhaust manifold studs (2) from cylinder head (1).

## Installation Procedure

---

### NOTICE

**Keep all parts clean from contaminants.**

**Contaminants may cause rapid wear and shortened component life.**

---

**Note:** The two cylinder, the three cylinder and the four cylinder engines have different exhaust manifolds. The installation procedure is similar for all models.

1. Ensure that the mating surfaces of the cylinder head and the exhaust manifold are clean and free from damage.
- 

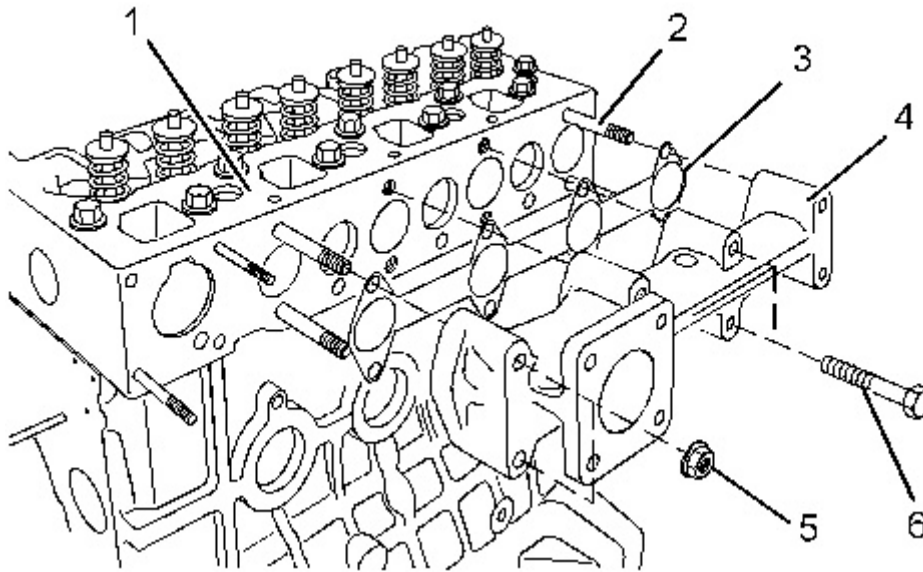

Illustration 2  
Typical example

g01326567

2. If necessary, install exhaust manifold studs (2) to cylinder head (1).
3. Install a new exhaust manifold gasket (3) to cylinder head (1).
4. Align exhaust manifold (4) with studs (2) and install the exhaust manifold to cylinder head (1).

**Note:** Ensure that the exhaust manifold is installed in the correct orientation.

5. Install nuts (5) and bolts (6) finger tight.

**Note:** Ensure that bolts of different lengths are installed in the correct positions.

6. For C0.5, C0.7, C1.1, C1.5 and C1.6 engines, tighten nuts (5) and bolts (6) to a torque of 10 N·m (89 lb in).

For C2.2 engines, tighten nuts (5) and bolts (6) to a torque of 25 N·m (18 lb ft).

**Note:** On three cylinder engines and four cylinder engines, tighten the inner bolts first.

### End By:

- a. If the engine is equipped with a turbocharger, install the turbocharger. Refer to Disassembly and Assembly, "Turbocharger, Remove and Install".
-

Product: INDUSTRIAL ENGINE  
Model: C2.2 INDUSTRIAL ENGINE C6M  
Configuration: C2.2 Industrial Engine C6M00001-UP

## Disassembly and Assembly C0.5, C0.7, C1.1, C1.5, C1.6 and and C2.2 Industrial Engines

Media Number -KENR6229-05

Publication Date -01/03/2007

Date Updated -14/07/2017

i02602642

# Inlet and Exhaust Valve Springs - Remove and Install

SMCS - 1108-010

## Removal Procedure

Table 1

Required Tools			
Tool	Part Number	Part Description	Qty
A	9U-6195	Valve Spring Compressor	1
B <sup>(1)</sup>	304-6597	Adapter	1
B <sup>(2)</sup>	268-1969	Adapter	1
B <sup>(3)</sup>	9U-6194	Adapter	1

<sup>(1)</sup> C0.5 and C0.7 engines

<sup>(2)</sup> C1.1 and C1.6 engines

<sup>(3)</sup> C1.5 and C2.2 engines

### Start By:

- Remove the rocker shaft assembly. Refer to Disassembly and Assembly, "Rocker Shaft and Pushrod - Remove".



**Personal injury can result from being struck by parts propelled by a released spring force.**

**Make sure to wear all necessary protective equipment.**

**Follow the recommended procedure and use all recommended tooling to release the spring force.**

---

---

**NOTICE**

**Keep all parts clean from contaminants.**

**Contaminants may cause rapid wear and shortened component life.**

---

---

**NOTICE**

**Install suitable plugs to the inlet ports of the cylinder head in order to prevent the entry of loose parts into the engine.**

---

---

**NOTICE**

**Plug the apertures for the push rods in the cylinder head in order to prevent the entry of loose parts into the engine.**

---

**Note:** The removal procedure is similar for the two cylinder, the three cylinder and the four cylinder engines. The following procedure should be adopted in order to remove the valve springs when the cylinder head is installed to the engine. Refer to Disassembly and Assembly, "Inlet and Exhaust Valves - Remove and Install" for the procedure to remove the valve springs from a cylinder head that has been removed from the engine.

**Note:** Ensure that the appropriate piston is at the top center position before the valve spring is removed. Failure to ensure that the piston is at the top center position may allow the valve to drop into the cylinder bore.

---

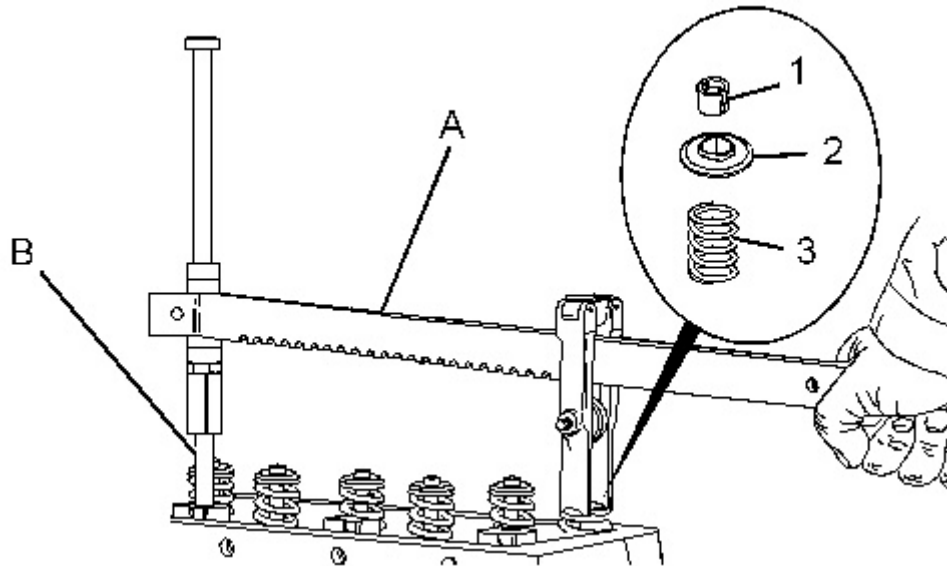

Illustration 1

g01304583

Typical example

1. Follow Steps 1.a through 1.d in order to position the appropriate piston at top center.
  - a. Install Tooling (A) and (B) in position on the cylinder head in order to compress a valve spring for the appropriate piston.
  - b. Use Tooling (A) in order to compress valve spring (3) and open the valve slightly.

**Note:** Do not compress the spring so that the valve spring retainer (2) touches the valve stem seal.
  - c. Carefully rotate the crankshaft until the piston touches the valve.

**Note:** Do not use excessive force to turn the crankshaft. The use of force can result in bent valve stems.
  - d. Continue to rotate the crankshaft and gradually release the pressure on Tooling (A) until the piston is at the top center position. The valve is now held in a position that allows the valve spring to be safely removed.

---

### NOTICE

**Ensure that the valve spring is compressed squarely or damage to the valve stem may occur.**

---

2. Use tool (A) in order to compress valve spring (3). Remove valve keepers (1).

**Note:** For four cylinder engines, if all valve springs require replacement the procedure can be carried out on two cylinders at the same time. The procedure can be carried out on the

following pairs of cylinders. 1 with 4 and 2 with 3. Ensure that all of the valve springs are installed before changing from one pair of cylinders to another pair of cylinders.

---

## NOTICE

**Do not turn the crankshaft while the valve springs are removed.**

---

3. Apply sufficient pressure to Tooling (A) in order to allow removal of the valve keepers (1).

**Note:** Do not compress the spring so that the valve spring retainer (2) touches the valve stem seal.

Remove valve keepers (1).

4. Slowly release the pressure on Tooling (A).
5. Remove valve spring retainer (2) and remove valve spring (3).
6. Remove Tooling (A) and (B).

## Installation Procedure

Table 2

Required Tools			
Tool	Part Number	Part Description	Qty
A	9U-6195	Valve Spring Compressor	1
B <sup>(1)</sup>	304-6597	Adapter	1
B <sup>(2)</sup>	268-1969	Adapter	1
B <sup>(3)</sup>	9U-6194	Adapter	1

<sup>(1)</sup> C0.5 and C0.7 engines

<sup>(2)</sup> C1.1 and C1.6 engines

<sup>(3)</sup> C1.5 and C2.2 engines

---

## NOTICE

**Keep all parts clean from contaminants.**

**Contaminants may cause rapid wear and shortened component life.**

---

---

## NOTICE

**Do not turn the crankshaft while the valve springs are removed.**

---

---

## NOTICE

**Plug the apertures for the push rods in the cylinder head in order to prevent the entry of loose parts into the engine.**

---

---

## NOTICE

**Install suitable plugs to the inlet ports of the cylinder head in order to prevent the entry of loose parts into the engine.**

---

---

1. Inspect the valve springs for the correct length. Refer to Specifications, "Cylinder Head Valves".
- 

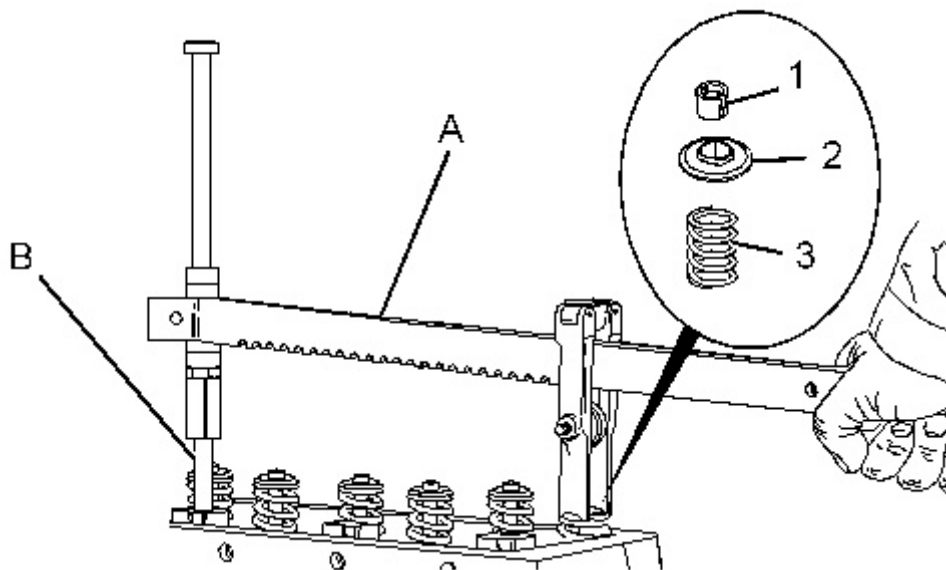

Illustration 2

Typical example

g01304583

2. Install valve spring (3) onto the cylinder head. Position valve spring retainer (2) onto valve spring (3).



 **WARNING**

**Improper assembly of parts that are spring loaded can cause bodily injury.**

**To prevent possible injury, follow the established assembly procedure and wear protective equipment.**

---

---

**NOTICE**

**Ensure that the valve spring is compressed squarely or damage to the valve stem may occur.**

---

3. Install Tooling (A) and (B) in the appropriate position on the cylinder head in order to compress the valve spring.

4. Apply sufficient pressure to Tooling (A) in order to install valve keepers (1).

**Note:** Do not compress the spring so that valve spring retainer (2) touches the valve stem seal.

Install the valve spring keepers.

5. Carefully release the pressure on Tooling (A).

**Note:** Ensure that the valve keepers are correctly seated.

 **WARNING**

**The valve spring keepers can be thrown from the valve when the valve spring compressor is released. Ensure that the valve spring keepers are properly installed on the valve stem. To help prevent personal injury, keep away from the front of the valve spring keepers and valve springs during the installation of the valves.**

---

6. Remove Tooling (A). Ensure that all of the valves are secured in place by a valve spring and valve keepers. Rotate the crankshaft through about 45 degrees in order to clear the piston from the valve. Lightly strike the top of the valve with a soft hammer in order to ensure that the valve keepers are properly installed.

**End By:**

- a. Install the rocker shaft assembly. Refer to Disassembly and Assembly, "Rocker Shaft and Pushrod - Install".
-

Product: INDUSTRIAL ENGINE  
Model: C2.2 INDUSTRIAL ENGINE C6M  
Configuration: C2.2 Industrial Engine C6M00001-UP

## Disassembly and Assembly C0.5, C0.7, C1.1, C1.5, C1.6 and and C2.2 Industrial Engines

Media Number -KENR6229-05

Publication Date -01/03/2007

Date Updated -14/07/2017

i02602643

# Inlet and Exhaust Valves - Remove and Install

SMCS - 1105-010

## Removal Procedure

Table 1

Required Tools			
Tool	Part Number	Part Description	Qty
A	1P-3527	Valve Spring Compressor	1

### Start By:

- Remove the cylinder head. Refer to Disassembly and Assembly, "Cylinder Head - Remove".

---

### NOTICE

**Keep all parts clean from contaminants.**

**Contaminants may cause rapid wear and shortened component life.**

---

**Note:** The removal procedure is identical for the two cylinder, the three cylinder and the four cylinder engines. The Illustrations show a four cylinder engine.

- Clean the bottom face of the cylinder head. Check the depth of the valves below the face of the cylinder head before the valve springs are removed. Refer to Specifications, "Cylinder Head Valves" for the correct dimensions.

2. Place a temporary identification mark on the heads of the valves in order to identify the correct position.

**Note:** Do not stamp the heads of the valves. Stamping or punching the heads of the valves could cause the valves to fracture.



**Personal injury can result from being struck by parts propelled by a released spring force.**

**Make sure to wear all necessary protective equipment.**

**Follow the recommended procedure and use all recommended tooling to release the spring force.**

---

---

### NOTICE

**Ensure that the valve spring is compressed squarely or damage to the valve stem may occur.**

---

---

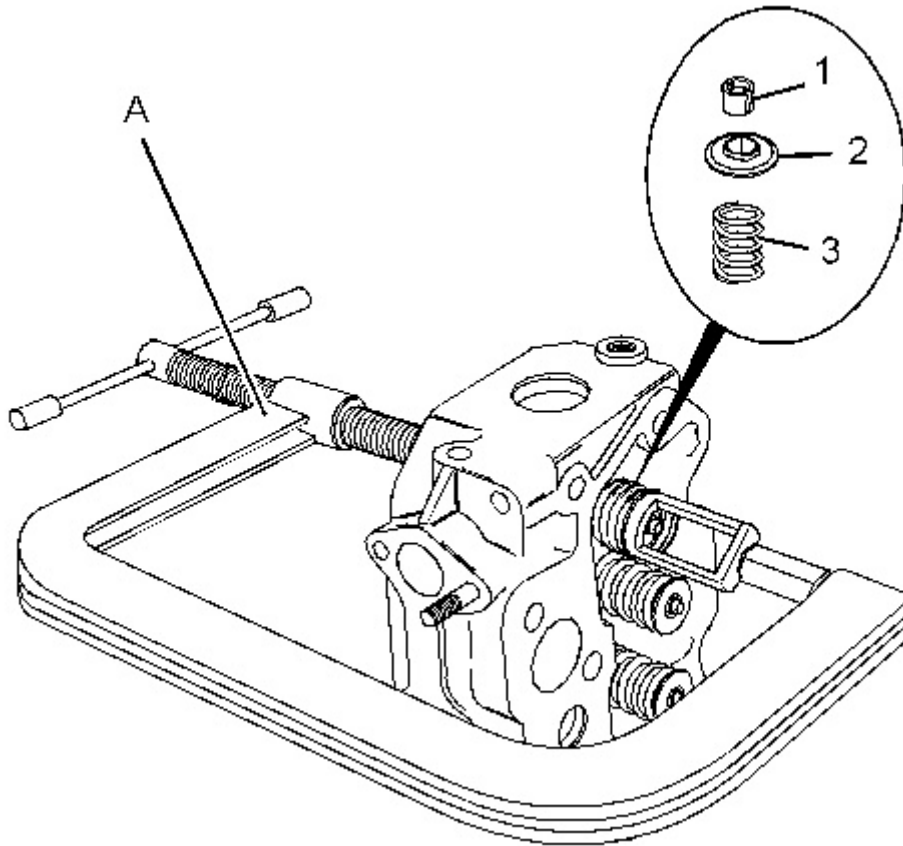

---

Illustration 1  
Typical example

g01315963

---

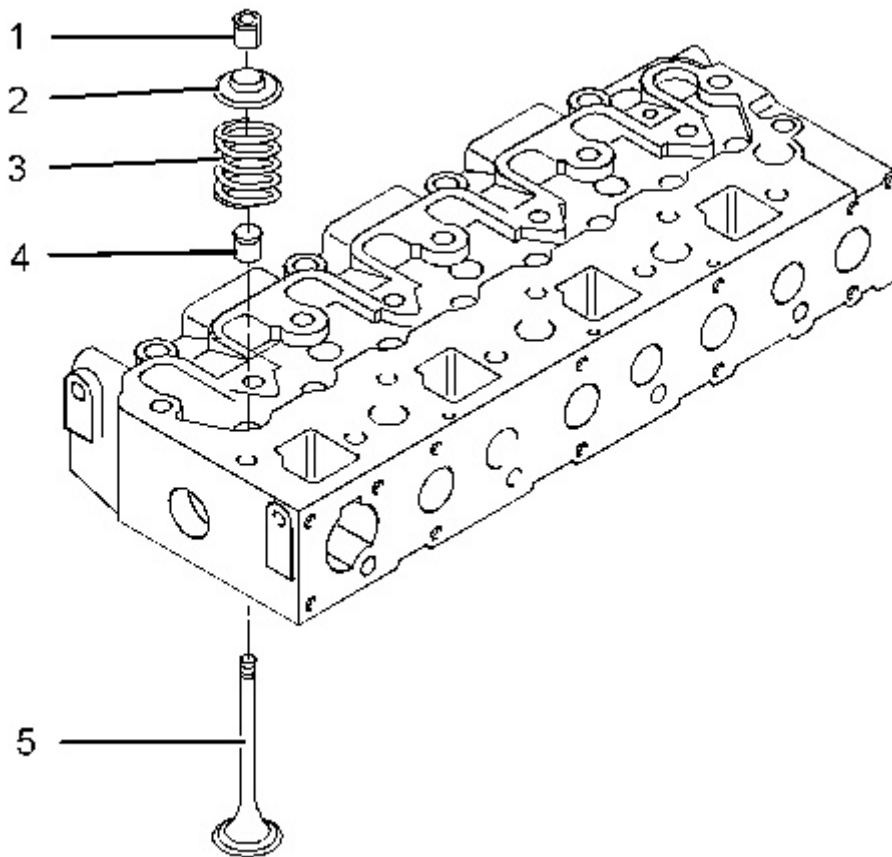

Illustration 2

g01325840

Typical example

3. Use Tooling (A) in order to compress the appropriate valve spring (3). Remove valve keepers (1).

**Note:** Do not compress the valve spring so that valve spring retainer (2) touches valve stem seal (4).

4. Remove Tooling (A).
5. Remove valve spring retainer (2). Remove valve spring (3).
6. Remove valve (5).
7. Remove valve stem seal (4).
8. Repeat Steps 3 to 7 for the remaining valves.

## Installation Procedure

Table 2

Required Tools			
Tool	Part Number	Part Description	Qty
A	1P-3527	Valve Spring Compressor	1

B <sup>(1)</sup>	304-6599	Valve Stem Seal Replacer	1
B <sup>(2)</sup>	256-4865	Valve Stem Seal Replacer	1

<sup>(1)</sup> C0.5 and C0.7 engines

<sup>(2)</sup> C1.1, C1.5, C1.6 and C2.2 engines

---

## NOTICE

**Keep all parts clean from contaminants.**

**Contaminants may cause rapid wear and shortened component life.**

---

**Note:** The installation procedure is identical for the two cylinder, the three cylinder and the four cylinder engines. The Illustrations show a four cylinder engine.

1. Clean all components of the cylinder head assembly. Ensure that all ports, all coolant passages and all lubrication passages in the cylinder head are free from debris. Follow Steps 1.a through 1.e in order to inspect the components of the cylinder head assembly. Replace any components that are worn or damaged.
    - a. Inspect the cylinder head for wear and for damage. Refer to Systems Operation, Testing and Adjusting, "Cylinder Head Inspect".
    - b. Inspect the valve seats for wear and for damage. Refer to Specifications, "Cylinder Head Valves" for further information.
    - c. Inspect the valve guides for wear and for damage. Refer to Specifications, "Cylinder Head Valves" and Systems Operation, Testing and Adjusting, "Valve Guide - Inspect" for further information.
    - d. Inspect the valves for wear and for damage. Refer to Specifications, "Cylinder Head Valves".
    - e. Inspect the valve springs for the correct length. Refer to Specifications, "Cylinder Head Valves".
-

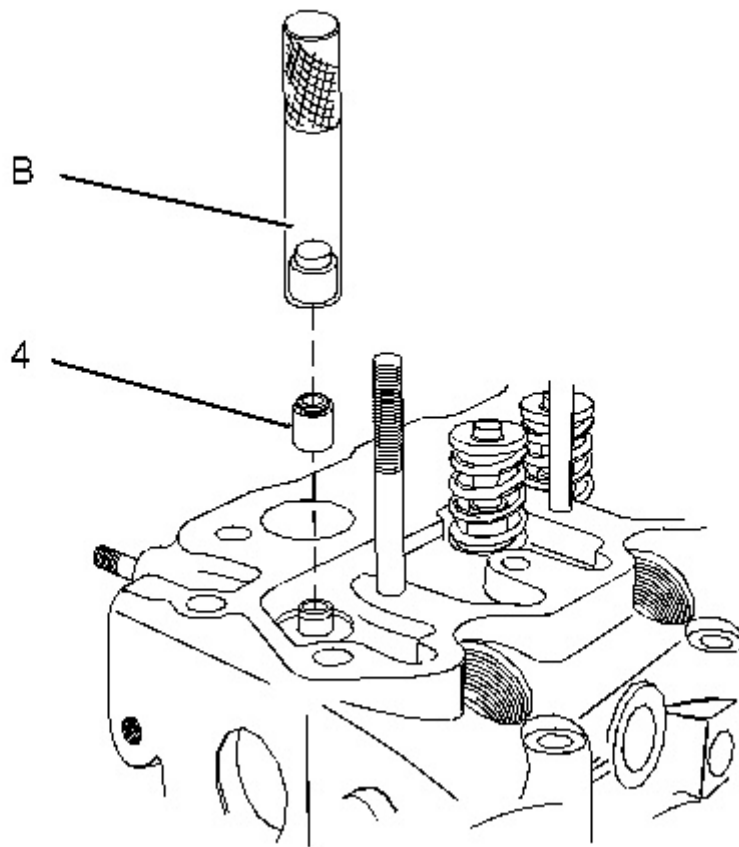

---

Illustration 3  
Typical example

g01315893

2. Use Tooling (B) to install new valve stem seals (4) onto each of the valve guides.

**Note:** The outer face of the valve guides must be clean and dry before installing the valve stem seals.

---



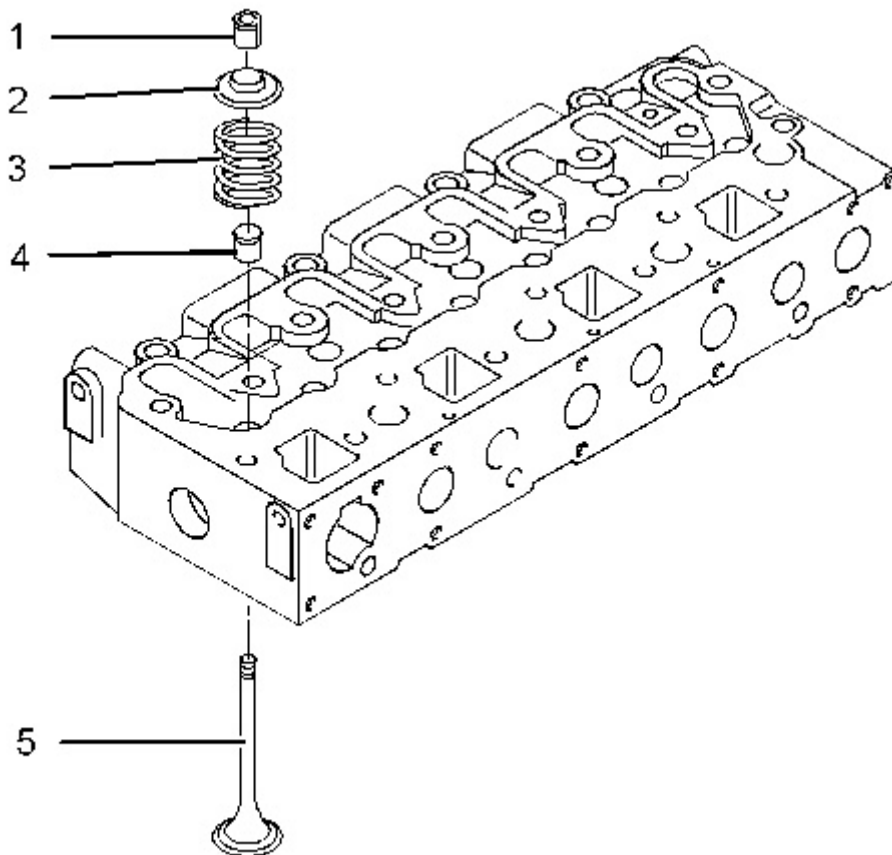

Illustration 4  
Typical example

g01325840

3. Lubricate the stem of valve (5) with clean engine oil. Install valve (5) in the appropriate position in the cylinder head. Check the depth of the valve below the face of the cylinder head. Refer to Systems Operation, Testing and Adjusting, "Valve Depth - Inspect" for more information.
4. Install valve spring (3) to the cylinder head. Position valve spring retainer (2) onto valve spring (3).

 **WARNING**

**Personal injury can result from being struck by parts propelled by a released spring force.**

**Make sure to wear all necessary protective equipment.**

**Follow the recommended procedure and use all recommended tooling to release the spring force.**

---

---

## NOTICE

Ensure that the valve spring is compressed squarely or damage to the valve stem may occur.

---

---

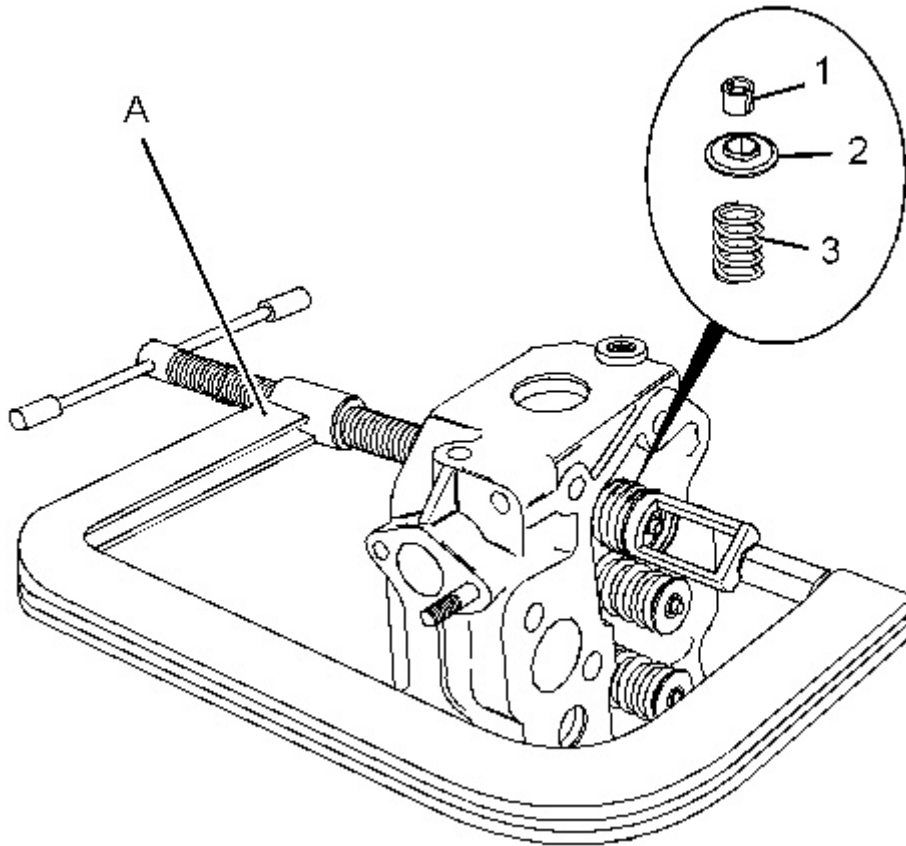

Illustration 5

g01315963

Typical example

5. Use Tooling (A) in order to compress valve spring (3). Install valve keepers (1).

**Note:** Do not compress the spring so that valve spring retainer (2) touches valve stem seal (4).

## **WARNING**

The valve spring keepers can be thrown from the valve when the valve spring compressor is released. Ensure that the valve spring keepers are properly installed on the valve stem. To help prevent personal injury, keep away from the front of the valve spring keepers and valve springs during the installation of the valves.

---

6. Remove Tooling (A).
7. Repeat Steps 4 to 6 for the remaining valves.
8. Place the cylinder head on a suitable support. Ensure that the heads of the valves are not obstructed. Gently strike the top of the valves with a soft hammer in order to ensure that valve keepers (1) are properly installed.

**End By:**

- a. Install the cylinder head. Refer to Disassembly and Assembly, "Cylinder Head - Install".
-

Product: INDUSTRIAL ENGINE  
Model: C2.2 INDUSTRIAL ENGINE C6M  
Configuration: C2.2 Industrial Engine C6M00001-UP

## **Disassembly and Assembly C0.5, C0.7, C1.1, C1.5, C1.6 and and C2.2 Industrial Engines**

Media Number -KENR6229-05

Publication Date -01/03/2007

Date Updated -14/07/2017

i02601947

# **Engine Oil Line - Remove and Install**

SMCS - 1307-010

## **Removal Procedure**

---

### **NOTICE**

**Keep all parts clean from contaminants.**

**Contaminants may cause rapid wear and shortened component life.**

---

---

### **NOTICE**

**Care must be taken to ensure that fluids are contained during performance of inspection, maintenance, testing, adjusting and repair of the product. Be prepared to collect the fluid with suitable containers before opening any compartment or disassembling any component containing fluids.**

**Dispose of all fluids according to local regulations and mandates.**

---

---

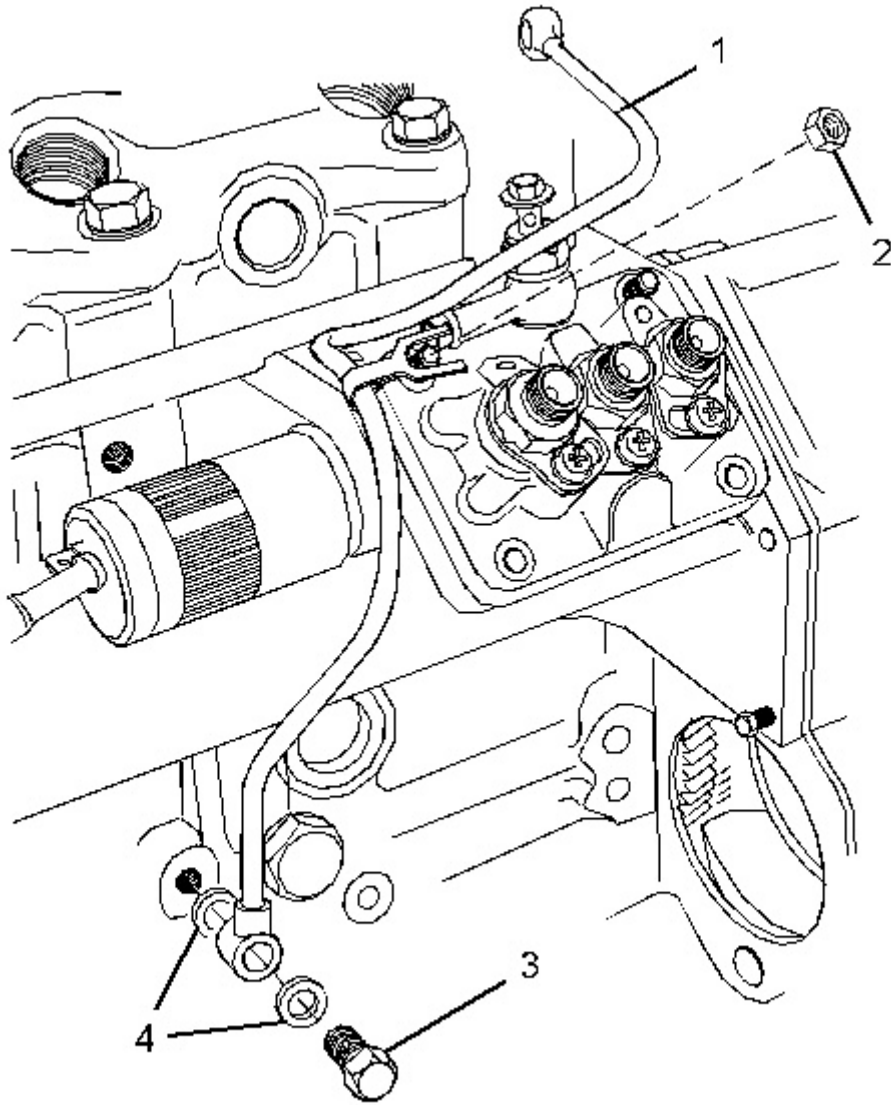

---

Illustration 1  
Typical example

g01304820

1. Loosen nut (2) that attaches the clip on oil line (1) to the fuel injection pump.
  2. Remove banjo bolt (3) and remove washers (4) from the cylinder block.
-

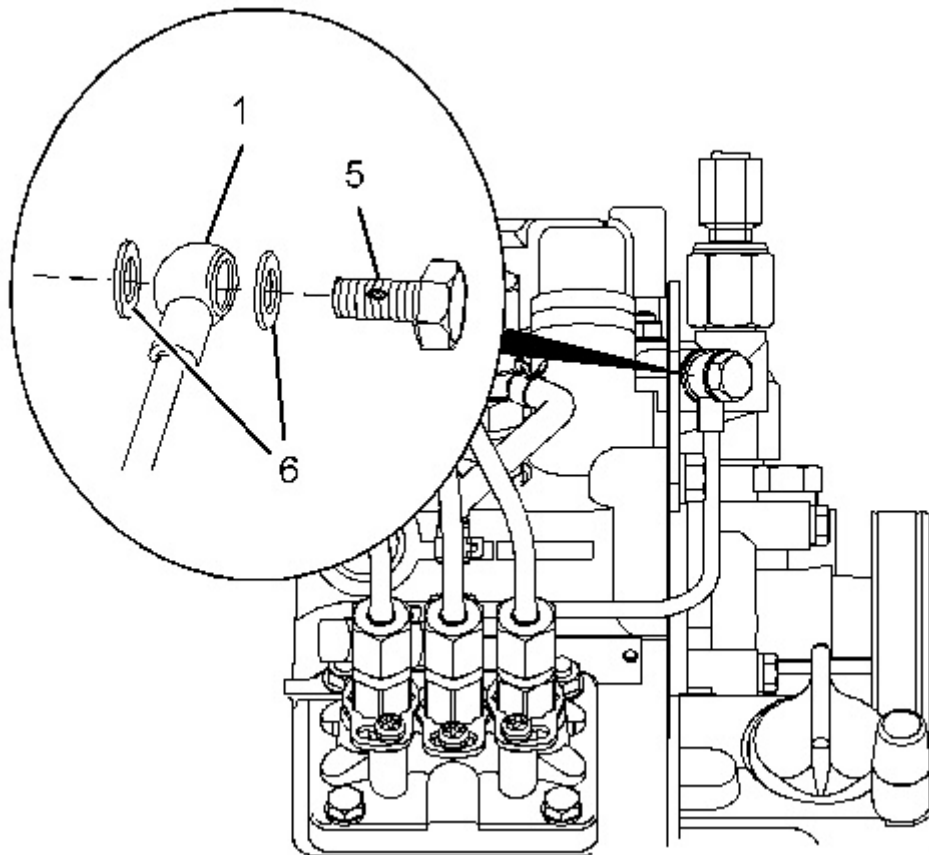

---

Illustration 2  
Typical example

g01307372

3. Remove banjo bolt (5) and remove washers (6) from the cylinder head.
4. Remove oil line (1) from the engine.

## Installation Procedure

---

### NOTICE

**Keep all parts clean from contaminants.**

**Contaminants may cause rapid wear and shortened component life.**

---

---

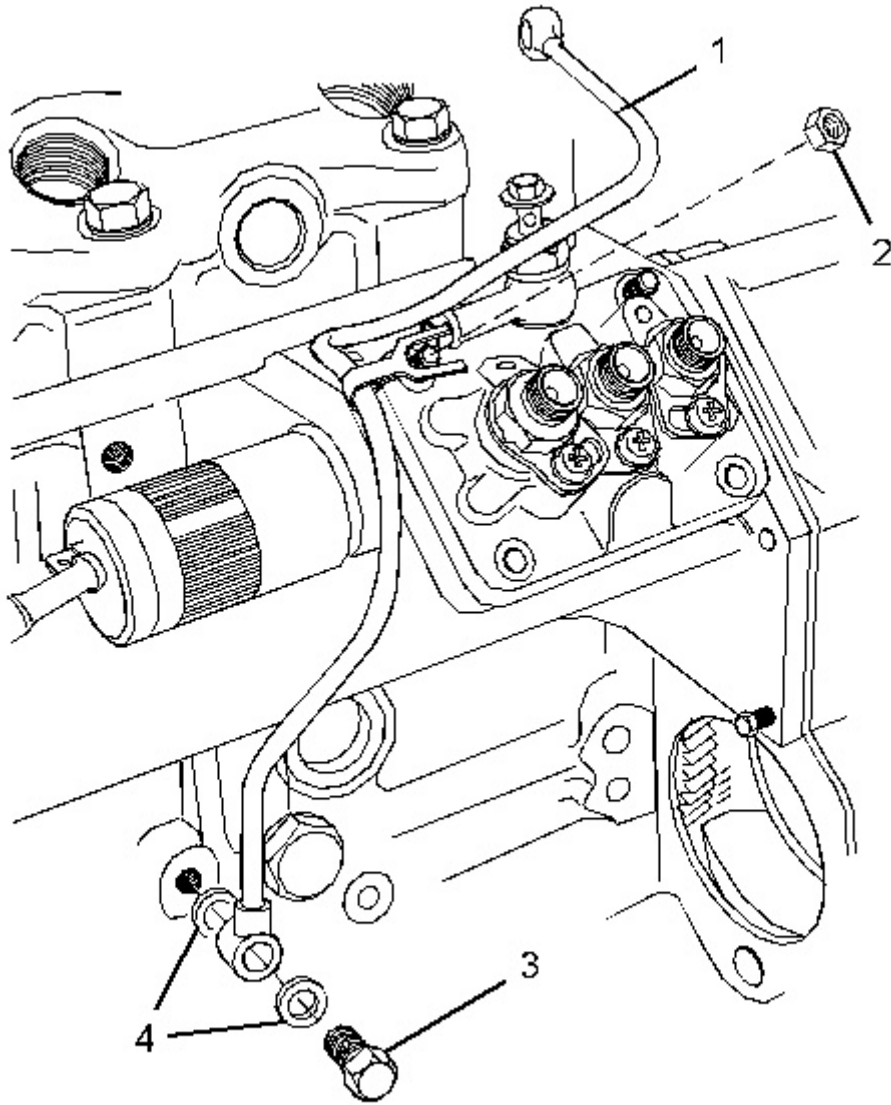

---

Illustration 3

g01304820

Typical example

1. Place oil line (1) on the engine. Ensure that the clip on the oil line is located below nut (2).
  2. Position banjo bolt (3) and new washers (4) onto oil line (1). Install the banjo bolt and oil line to the cylinder block finger tight.
-

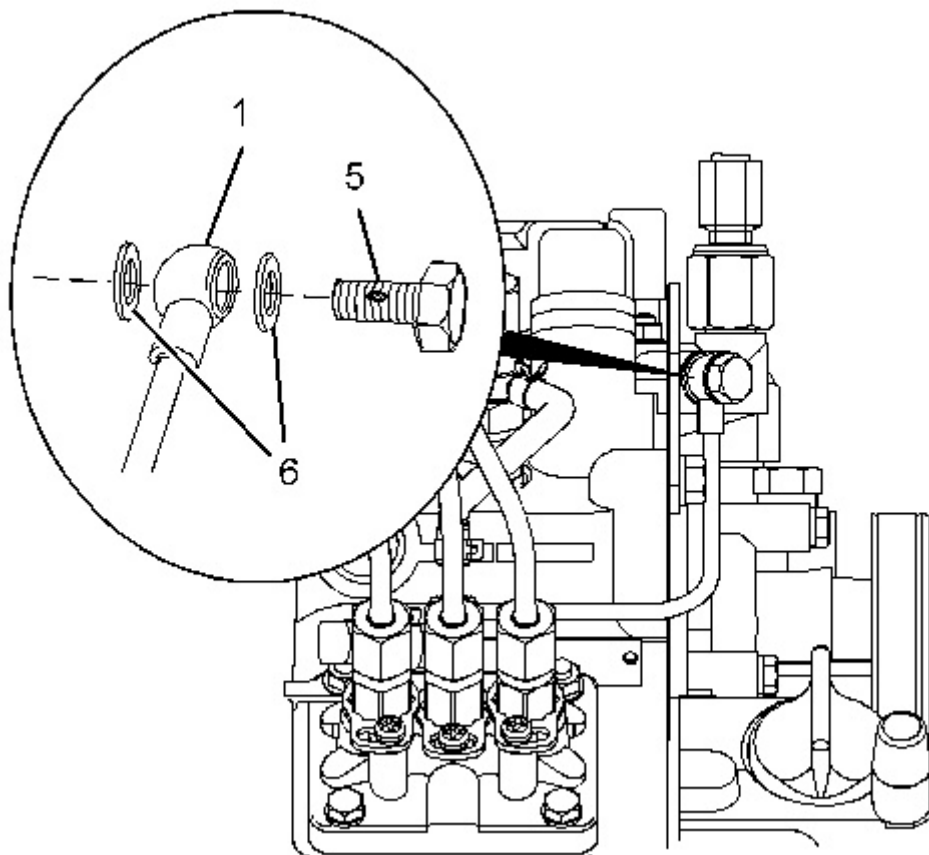

---

Illustration 4  
Typical example

g01307372

3. Position banjo bolt (5) and new washers (6) onto oil line (1). Install the banjo bolt and the oil line to the cylinder head finger tight.
  4. Tighten nut (2) that attaches the clip on oil line (1) to the fuel injection pump.  
For C0.5, C0.7, C1.1 and C1.6 engines, tighten nut (2) to a torque of 6 N·m (53 lb in).  
For C1.5 and C2.2 engines, tighten nut (2) to a torque of 15 N·m (133 lb in).
  5. Tighten banjo bolts (3) and (5) to a torque of 12 N·m (106 lb in).
-



Thank you so much for reading.  
Please click the “Buy Now!”  
button below to download the  
complete manual.



After you pay.

You can download the most  
perfect and complete manual in  
the world immediately.

Our support email:

[ebooklibonline@outlook.com](mailto:ebooklibonline@outlook.com)