

Product: ENGINE - MACHINE  
Model: C4.4 ENGINE - MACHINE W23  
Configuration: C4.4 Industrial Engine W2300001-UP

## Disassembly and Assembly C4.4 Industrial Engine

Media Number -UENR4457-00

Publication Date -01/09/2014

Date Updated -09/09/2014

i06960689

# Inlet and Exhaust Valve Springs - Remove and Install

SMCS - 1108-010

## Removal Procedure

Table 1

Required Tools			
Tool	Part Number	Part Description	Qty
A	1P-1860	Retaining Ring Pliers	1
B	9U-6193	Valve Spring Compressor	1
	416-0288	Adapter	1
	416-0292	Head	1
C <sup>(1)</sup>	9U-6198	Crankshaft Turning Tool	1
C <sup>(2)</sup>	9U-7336	Housing	1
	5P-7305	Engine Turning Tool	1

<sup>(1)</sup> The Crankshaft Turning Tool is used on the front pulley.

<sup>(2)</sup> This Tool is used in the aperture for the electric starting motor.

### Start By:

- a. Remove the rocker shaft assembly. Refer to Disassembly and Assembly, "Rocker Shaft and Pushrod - Remove".

**Note:** Either Tooling (C) can be used. Use the Tooling that is most suitable.

---

**NOTICE**

**Keep all parts clean from contaminants.**

**Contaminants may cause rapid wear and shortened component life.**

---

**Note:** The following procedure should be adopted to remove the valve springs when the cylinder head is installed to the engine. Refer to Disassembly and Assembly, "Inlet and Exhaust Valves - Remove and Install" for the procedure to remove the valve springs from a cylinder head that has been removed from the engine.

**Note:** Ensure that the appropriate piston is at the top center position before the valve spring is removed. Failure to ensure that the piston is at the top center position may allow the valve to drop into the cylinder bore.

---

### **NOTICE**

**Plug the apertures for the push rods in the cylinder head in order to prevent the entry of loose parts into the engine.**

---

---

### **NOTICE**

**Use a deep socket in order to remove the electrical connections from the electronic unit injectors. Use of incorrect tooling will result in damage to the electronic unit injectors.**

---

1. Turn the battery disconnect switch to the OFF position.
-

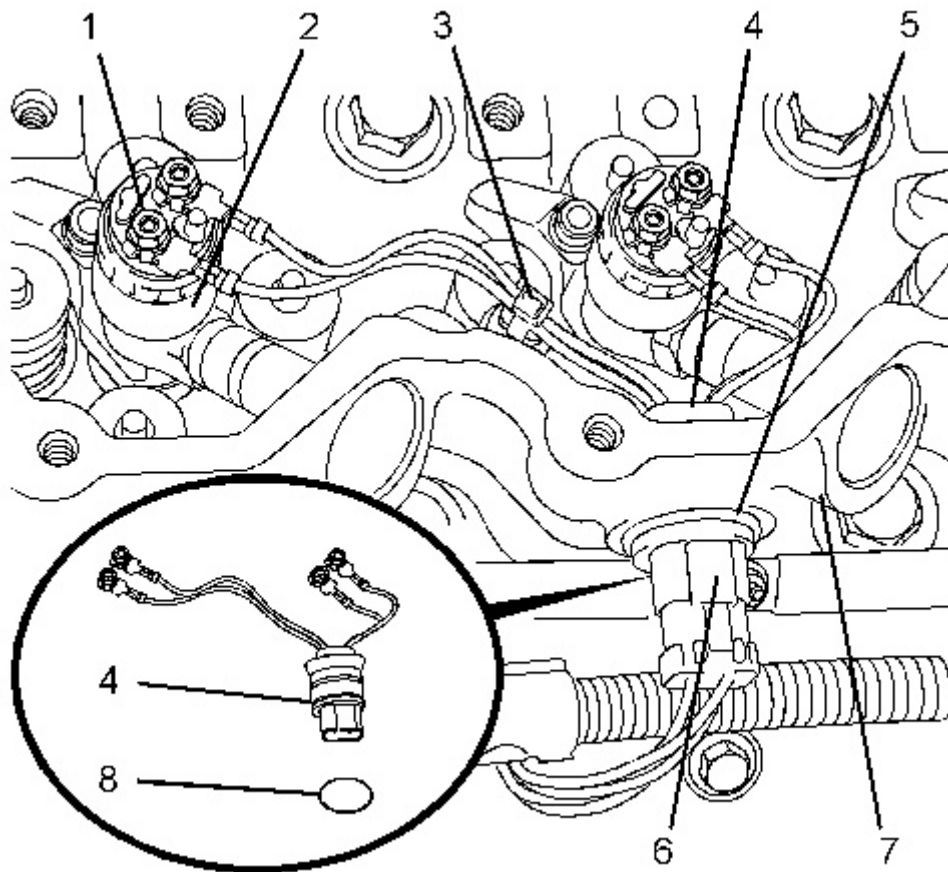

Illustration 1  
Typical example

g01469791

2. Follow Step 2.a through Step 2.h to remove the harness assemblies for the electronic unit injectors.
  - a. Place a temporary identification mark on connections (1).
  - b. Use a deep socket to remove connections (1) from electronic unit injectors (2).
  - c. Cut cable strap (3).
  - d. Disconnect plug (6) from harness assembly (4).
  - e. Use Tooling (A) to remove circlip (5).
  - f. From the outside of valve mechanism cover base (7), push harness assembly (4) inward. Withdraw the harness assembly from the valve mechanism cover base.
  - g. Remove O-ring seal (8) from harness assembly (4).
  - h. Repeat Step 2.a through Step 2.g to remove the remaining harness assembly.

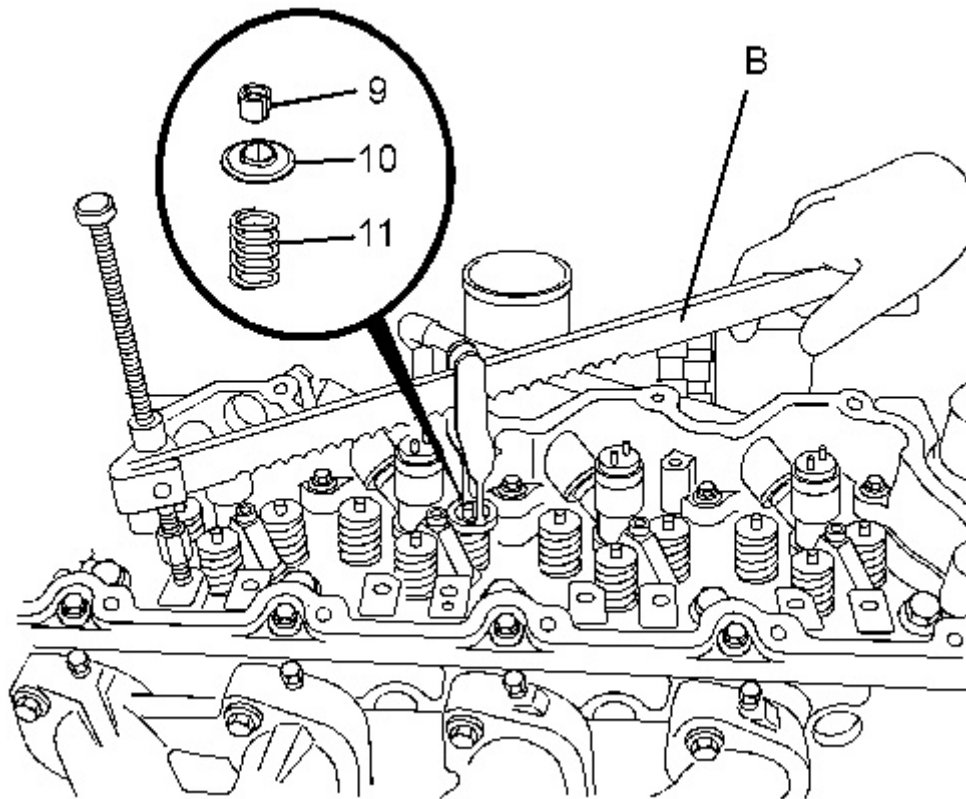

Illustration 2  
Typical example

g01469792

**! WARNING**

**Personal injury can result from being struck by parts propelled by a released spring force.**

**Make sure to wear all necessary protective equipment.**

**Follow the recommended procedure and use all recommended tooling to release the spring force.**

**NOTICE**

**Ensure that the valve spring is compressed squarely or damage to the valve stem may occur.**

3. Follow Step 3.a through Step 3.d to position the appropriate piston at top dead center.

- a. Install Tooling (B) in position on the cylinder head to compress a valve spring for the appropriate piston.
- b. Use Tooling (B) to compress valve spring (11) and open the valve slightly.
 

**Note:** Do not compress the spring so that valve spring retainer (10) touches the valve stem seal.
- c. Use Tooling (C) to rotate the crankshaft carefully, until the piston touches the valve.
 

**Note:** Do not use excessive force to turn the crankshaft. The use of force can result in bent valve stems.
- d. Continue to rotate the crankshaft and gradually release the pressure on Tooling (B) until the piston is at the top center position. The valve is now held in a position that allows the valve spring to be safely removed.

**Note:** Valve springs must be replaced in pairs for the inlet valve or the exhaust valve of each cylinder. If all valve springs require replacement the procedure can be carried out on two cylinders at the same time. The procedure can be carried out on the following pairs of cylinders. 1 with 4 and 2 with 3. Ensure that all the valve springs are installed before changing from one pair of cylinders to another pair of cylinders.

---

### NOTICE

**Do not turn the crankshaft while the valve springs are removed.**

---

4. Apply sufficient pressure to Tooling (B) to allow removal of valve keepers (9).
 

**Note:** Do not compress the spring so that valve spring retainer (10) touches the valve stem seal .

Remove valve keepers (9).
5. Slowly release the pressure on Tooling (B).
6. Remove valve spring retainer (10) and remove valve spring (11).
7. If necessary, remove the valve stem seals.
8. Repeat Step 4 through Step 7 to remove the remaining valve springs from the appropriate cylinder.
9. Remove Tooling (B).

## Installation Procedure

Table 2

Required Tools	

Tool	Part Number	Part Description	Qty
A	1P-1860	Retaining Ring Pliers	1
	9U-6193	Valve Spring Compressor	1
B	416-0288	Adapter	1
	416-0292	Head	1
C <sup>(1)</sup>	9U-6198	Crankshaft Turning Tool	1
C <sup>(2)</sup>	9U-7336	Housing	1
	5P-7305	Engine Turning Tool	1
D	247-5377	Torque Wrench	1

<sup>(1)</sup> The Crankshaft Turning Tool is used on the front pulley.

<sup>(2)</sup> This Tool is used in the aperture for the electric starting motor.

**Note:** Either Tooling (C) can be used. Use the Tooling that is most suitable.

---

### NOTICE

**Keep all parts clean from contaminants.**

**Contaminants may cause rapid wear and shortened component life.**

---



---

### NOTICE

**Do not turn the crankshaft while the valve springs are removed.**

---



---

### NOTICE

**Plug the apertures for the push rods in the cylinder head in order to prevent the entry of loose parts into the engine.**

---



---

### NOTICE

**Use a deep socket in order to remove the electrical connections from the electronic unit injectors. Use of incorrect tooling will result in damage to the electronic unit injectors.**

- 
1. Inspect the valve springs for the correct length. Refer to Specifications, "Cylinder Head Valves".
  2. If necessary, install a new valve stem seal onto the valve guide.

**Note:** The outer face of the valve guide must be clean and dry before installing the valve stem seal.

---

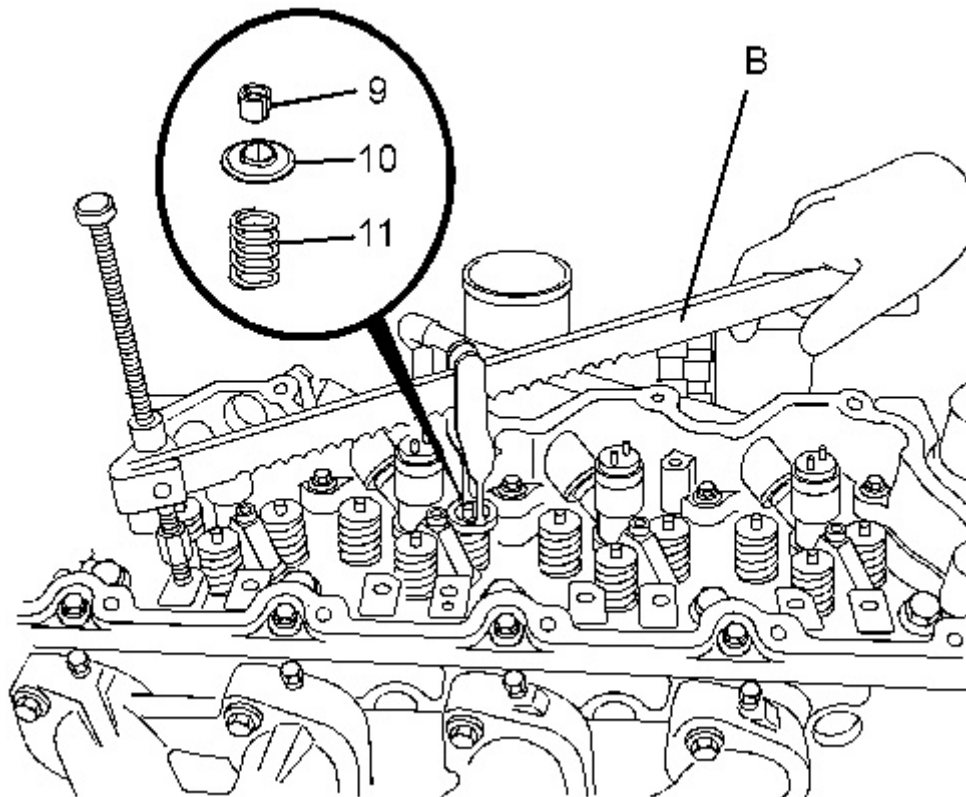

---

Illustration 3  
Typical example

g01469792

3. Install valve spring (11) onto the cylinder head. Position valve spring retainer (10) onto valve spring (11).

 **WARNING**

**Improper assembly of parts that are spring loaded can cause bodily injury.**

**To prevent possible injury, follow the established assembly procedure and wear protective equipment.**

---

---

## NOTICE

---

**Ensure that the valve spring is compressed squarely or damage to the valve stem may occur.**

---

4. Install Tooling (B) in the appropriate position on the cylinder head to compress the valve spring.

5. Apply sufficient pressure to Tooling (B) to install valve keepers (9).

**Note:** Do not compress the spring so that valve spring retainer (10) touches the valve stem seal .

Install the valve spring keepers.

6. Carefully release the pressure on Tooling (B).

**Note:** Ensure that the valve keepers are correctly seated.

7. Repeat Step 2 through Step 6 for the remaining valves.



**The valve spring keepers can be thrown from the valve when the valve spring compressor is released. Ensure that the valve spring keepers are properly installed on the valve stem. To help prevent personal injury, keep away from the front of the valve spring keepers and valve springs during the installation of the valves.**

---

8. Remove Tooling (B).

**Note:** Valve springs must be replaced in pairs for the inlet valve or the exhaust valve of each cylinder. If all valve springs require replacement the procedure can be carried out on two cylinders at the same time. The procedure can be carried out on the following pairs of cylinders. 1 with 4 and 2 with 3. Ensure that all the valve springs are installed before changing from one pair of cylinders to another pair of cylinders.

---



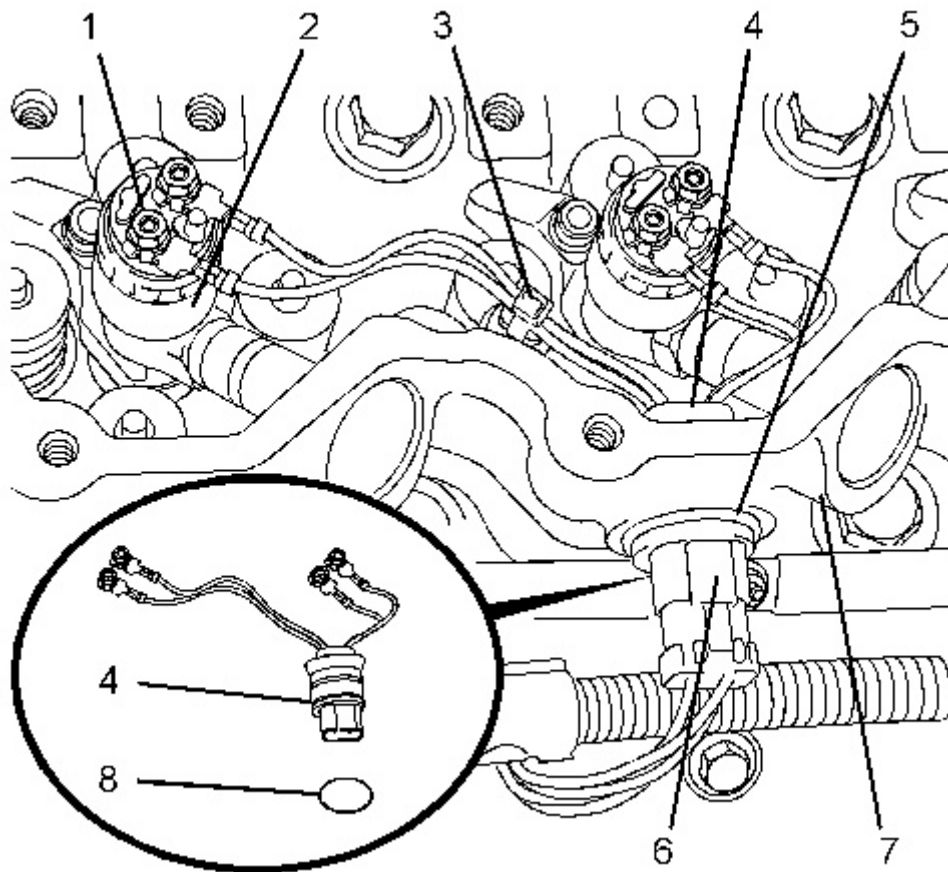

Illustration 4  
Typical example

g01469791

9. Follow Step 9.a through Step 9.g to install the harness assemblies for the electronic unit injectors.
  - a. Ensure that harness assembly (4) and the bore in the valve mechanism cover base (7) are clean and free from damage.
  - b. Install new O-ring seal (8) onto harness assembly (4).
  - c. From inside the valve mechanism cover base (7), push harness assembly (4) into the valve mechanism cover base.
  - d. Use Tooling (A) to install circlip (5).
  - e. Connect plug (6) to harness assembly (4).
  - f. Use a deep socket to install connections (1) to electronic unit injectors (2). Use Tooling (D) to tighten the connections to a torque of 2.4 N·m (21.24 lb in).
  - g. Install a new cable strap (3).
 

**Note:** Ensure that the cable straps conform to the Caterpillar specification.
  - h. Repeat Step 9.a through Step 9.g to install the remaining harness assembly.
10. Turn the battery disconnect switch to the ON position.

**End By:**

- a. Install the rocker shaft assembly. Refer to Disassembly and Assembly, "Rocker Shaft and Pushrods - Install".
-

Product: ENGINE - MACHINE  
Model: C4.4 ENGINE - MACHINE W23  
Configuration: C4.4 Industrial Engine W2300001-UP

## Disassembly and Assembly C4.4 Industrial Engine

Media Number -UENR4457-00

Publication Date -01/09/2014

Date Updated -09/09/2014

i05820991

# Inlet and Exhaust Valves - Remove and Install

SMCS - 1105-010

## Removal Procedure

Table 1

Required Tools			
Tool	Part Number	Part Description	Qty
A	9U-6195	Valve Spring Compressor	1
	268-1969	Adapter	1
	276-1221	Head	1

### Start By:

- Remove the cylinder head. Refer to Disassembly and Assembly, "Cylinder Head - Remove".

---

### NOTICE

**Keep all parts clean from contaminants.**

**Contaminants may cause rapid wear and shortened component life.**

---

- Clean the bottom gasket surface of the cylinder head. Check the depth of the valves below the face of the cylinder head before the valve springs are removed. Refer to Specifications, "Cylinder Head Valves" for the correct dimensions.

2. Place a temporary identification mark on the heads of the valves in order to identify the correct position. Inlet valves have a recess in the center of the head.

**Note:** Do not stamp the heads of the valve. Stamping or punching the heads of the valves could cause the valves to fracture.

3. Use a suitable lifting device to position the cylinder head with the valve springs upward. The weight of the cylinder head is approximately 56 kg (125 lb).

**Note:** Ensure that the cylinder head is kept on a clean, soft surface in order to prevent damage to the machined face.

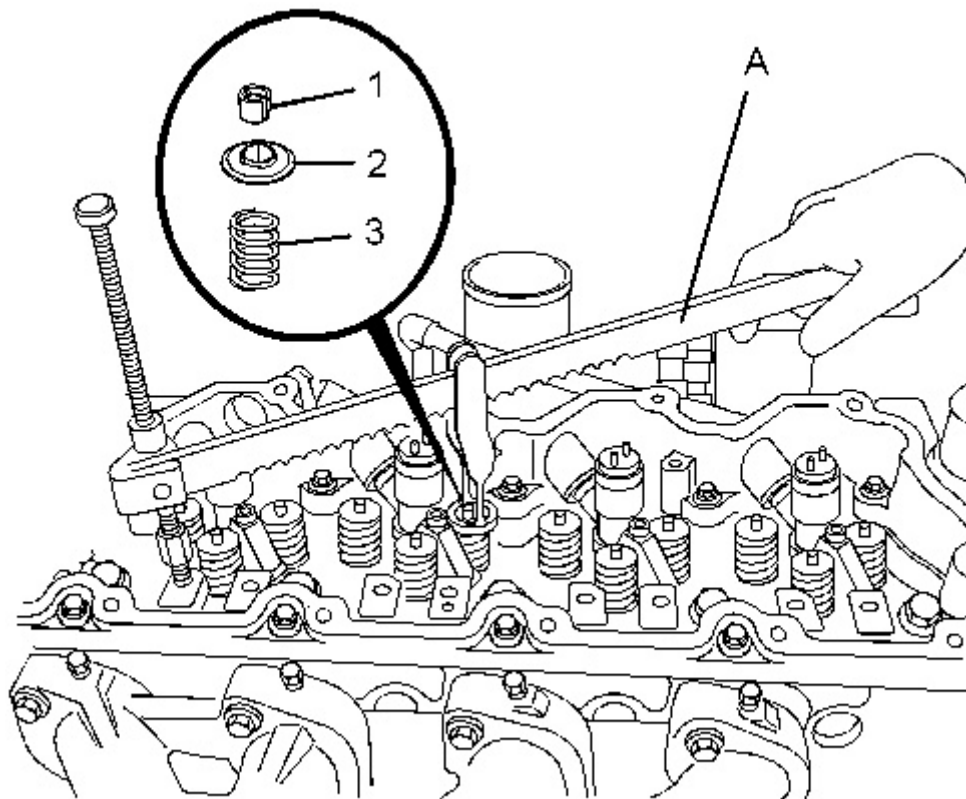

---

Illustration 1  
Typical example

g01469809

**! WARNING**

**Personal injury can result from being struck by parts propelled by a released spring force.**

**Make sure to wear all necessary protective equipment.**

**Follow the recommended procedure and use all recommended tooling to release the spring force.**

- 
4. Install Tooling (A) in position on the cylinder head in order to compress the appropriate valve spring.

---

### NOTICE

**Ensure that the valve spring is compressed squarely or damage to the valve stem may occur.**

---

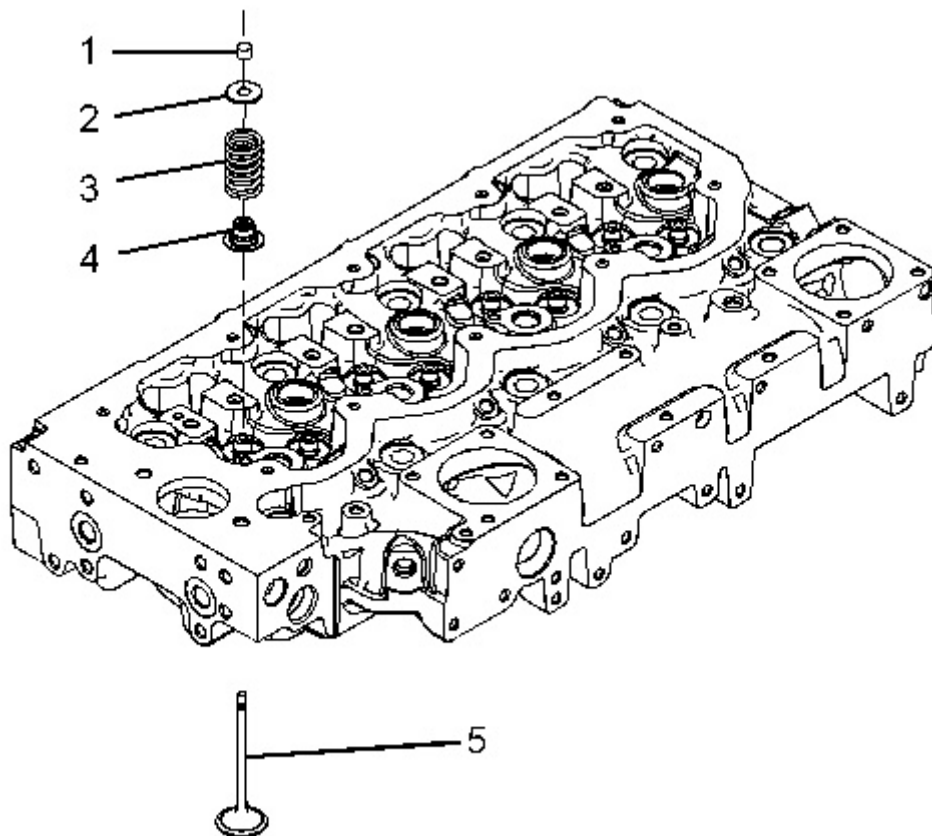

---

Illustration 2

g01245105

5. Apply sufficient pressure to Tooling (A) in order to remove valve keepers (1).

**Note:** Do not compress the spring so that valve spring retainer (2) touches valve stem seal (4).

6. Slowly release the pressure on Tooling (A).
7. Remove valve spring retainer (2). Remove valve spring (3).
8. Repeat Step 4 through Step 7 for the remaining valves.

9. Remove Tooling (A).
10. Remove valve stem seals (4).
11. Use a suitable lifting device to carefully turn over the cylinder head.
12. Remove valves (5).

## Installation Procedure

Table 2

Required Tools			
Tool	Part Number	Part Description	Qty
A	9U-6195	Valve Spring Compressor	1
	268-1969	Adapter	1
	276-1221	Head	1

---

### NOTICE

**Keep all parts clean from contaminants.**

**Contaminants may cause rapid wear and shortened component life.**

---

1. Clean all components of the cylinder head assembly. Ensure that all ports, all coolant passages, and all lubrication passages in the cylinder head are free from debris. Follow Step 1.a through Step 1.e in order to inspect the components of the cylinder head assembly. Replace any components that are worn or damaged.
    - a. Inspect the cylinder head for wear and for damage. Refer to Systems Operation, Testing and Adjusting, "Cylinder Head Inspect".
    - b. Inspect the valve seats for wear and for damage. Refer to Specifications, "Cylinder Head Valves" for further information.
    - c. Inspect the valve guides for wear and for damage. Refer to Specifications, "Cylinder Head Valves" and Systems Operation, Testing and Adjusting, "Valve Guide - Inspect" for further information.
    - d. Inspect the valves for wear and for damage. Refer to Specifications, "Cylinder Head Valves".
    - e. Inspect the valve springs for damage and for the correct length. Refer to Specifications, "Cylinder Head Valves".
-

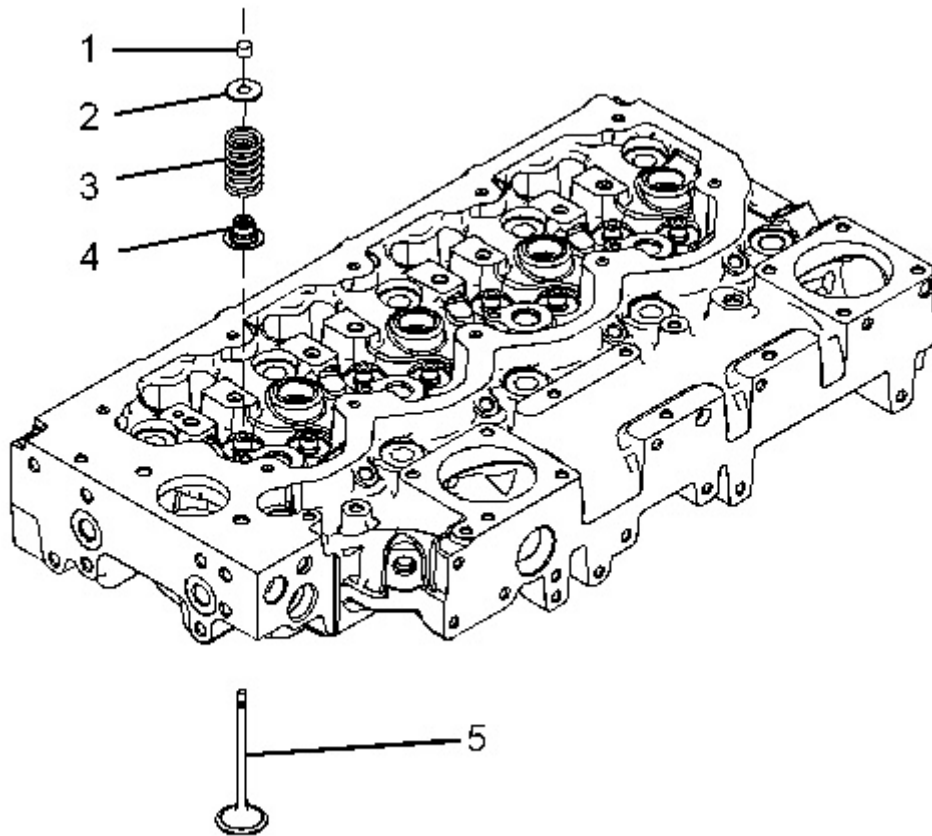

---

Illustration 3

g01245105

2. Lubricate the stems of valves (5) with clean engine oil. Install valves (5) in the appropriate positions in the cylinder head. Check the depth of the valves below the face of the cylinder head. Refer to Systems Operation, Testing and Adjusting, "Valve Depth - Inspect" for more information.
3. Use a suitable lifting device to carefully turn over the cylinder head. The weight of the cylinder head is approximately 56 kg (125 lb).

**Note:** Ensure that all of the valves remain in place.

4. Install new valve stem seals (4) onto each of the valve guides.

**Note:** The outer face of the valve guides must be clean and dry before installing the valve stem seals.

5. Install valve spring (3) onto the cylinder head. Position valve spring retainer (2) onto valve spring (3).
-

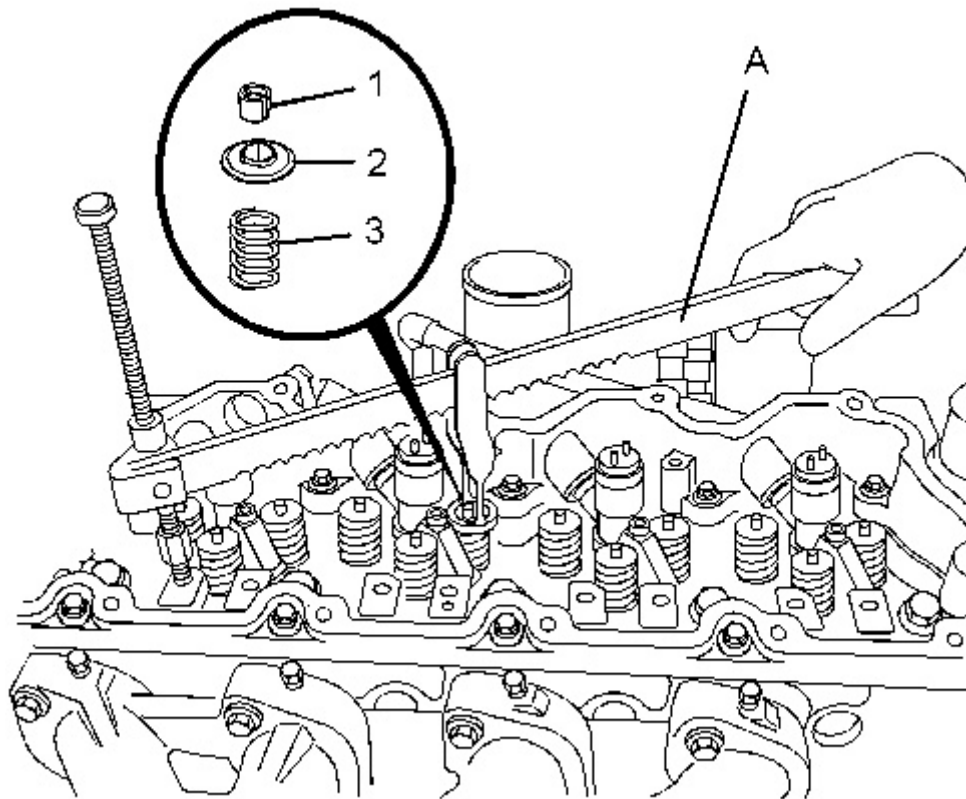

Illustration 4  
Typical example

g01469809

**! WARNING**

**Personal injury can result from being struck by parts propelled by a released spring force.**

**Make sure to wear all necessary protective equipment.**

**Follow the recommended procedure and use all recommended tooling to release the spring force.**

- 
6. Install Tooling (A) in the appropriate position on the cylinder head in order to compress valve spring (3).

---

**NOTICE**

**Ensure that the valve spring is compressed squarely or damage to the valve stem may occur.**



---

7. Apply sufficient pressure to Tooling (A) in order to install valve keepers (1).

**Note:** Do not compress the spring so that valve spring retainer (2) touches valve stem seal (4).



**The valve spring keepers can be thrown from the valve when the valve spring compressor is released. Ensure that the valve spring keepers are properly installed on the valve stem. To help prevent personal injury, keep away from the front of the valve spring keepers and valve springs during the installation of the valves.**

---

8. Carefully release the pressure on Tooling (A).

9. Repeat Step 5 through Step 8 for the remaining valves.

10. Remove Tooling (A) from the cylinder head.

11. Use a suitable lifting device to position the cylinder head on a support. Ensure that the heads of the valves are not obstructed.

**End By:**

a. Install the cylinder head. Refer to Disassembly and Assembly, "Cylinder Head - Install".

---

Product: ENGINE - MACHINE  
Model: C4.4 ENGINE - MACHINE W23  
Configuration: C4.4 Industrial Engine W2300001-UP

## Disassembly and Assembly C4.4 Industrial Engine

Media Number -UENR4457-00

Publication Date -01/09/2014

Date Updated -09/09/2014

i05812267

# Engine Oil Filter Base - Remove and Install

SMCS - 1306-010

## Removal Procedure

Table 1

Required Tools			
Tool	Part Number	Part Description	Qty
A	185-3630	Strap Wrench	1

**Note:** The oil filter may be installed vertically or the oil filter may be installed horizontally.

---

### NOTICE

**Keep all parts clean from contaminants.**

**Contaminants may cause rapid wear and shortened component life.**

---

### NOTICE

**Care must be taken to ensure that fluids are contained during performance of inspection, maintenance, testing, adjusting and repair of the product. Be prepared to collect the fluid with suitable containers before opening any compartment or disassembling any component containing fluids.**

**Dispose of all fluids according to local regulations and mandates.**

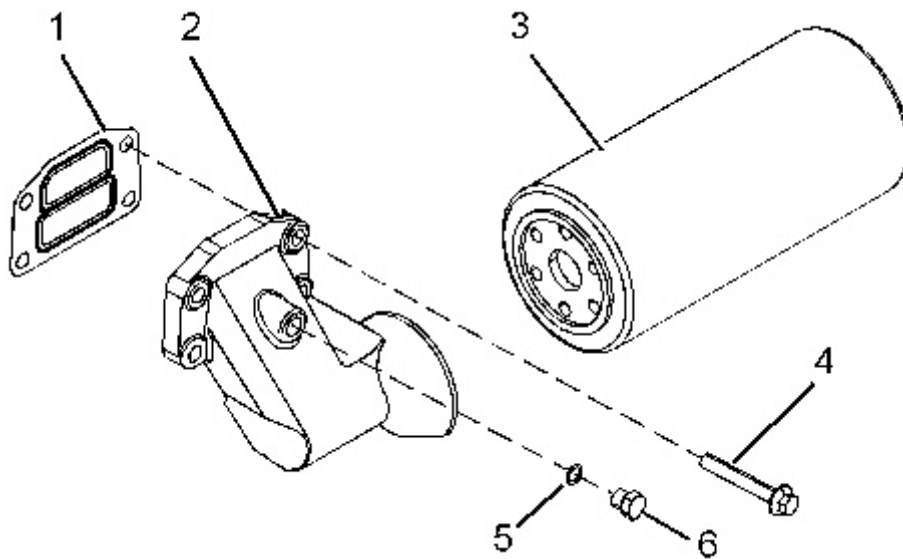

Illustration 1  
Typical example

g01343554

1. Use Tooling (A) to remove engine oil filter (3). Refer to Operation and Maintenance Manual, "Engine Oil and Filter - Change".
2. If the engine oil pressure sensor is located in the engine oil filter base, remove the engine oil pressure sensor. Refer to Disassembly and Assembly, "Engine Oil Pressure Sensor - Remove and Install".
3. Remove bolts (4) and remove engine oil filter base (2).
4. Remove joint (1).
5. If the engine oil filter base has a spacer plate, remove the spacer plate and remove the joint.
6. If necessary, remove plug (6) from engine oil filter base (2). Remove O-ring seal (5) from the plug.

## Installation Procedure

Table 2

Required Tools			
Tool	Part Number	Part Description	Qty
B	4C-4030	Thread Lock Compound	1

**NOTICE**

**Keep all parts clean from contaminants.**

**Contaminants may cause rapid wear and shortened component life.**

---

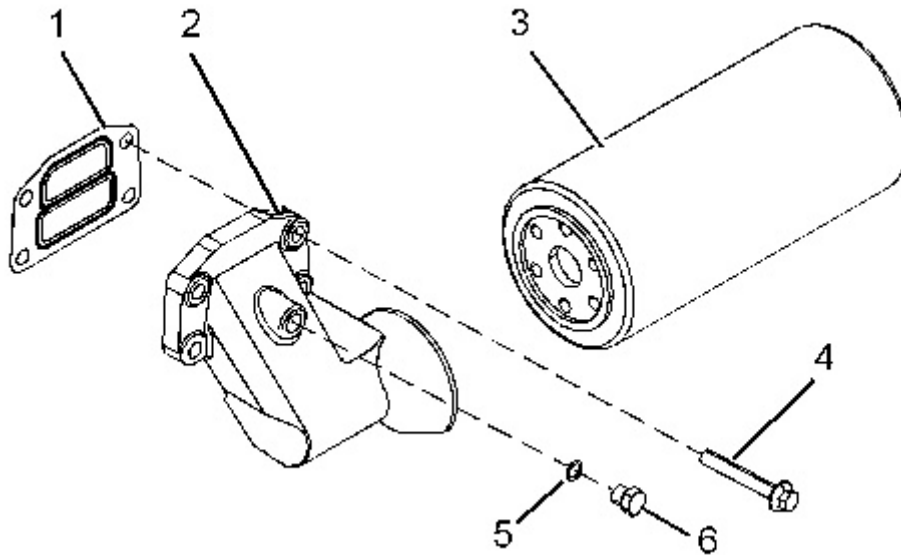

Illustration 2

g01343554

Typical example

1. Ensure that the engine oil filter base is clean. Clean the mating surfaces of the cylinder block.
  2. If necessary, install a new O-ring seal (5) to plug (6). Install plug (6) to engine oil filter base (2). Tighten the plug to a torque of 12 N·m (106 lb in).
  3. Install bolts (4) to engine oil filter base (2).
  4. Install a new joint (1) onto bolts (4). If the engine oil filter base has a spacer plate, install the spacer plate and a new joint onto the bolts.
  5. Apply Tooling (B) to the threads of the bolts. Install the assembly of the engine oil filter base to the cylinder block.
  6. Tighten bolts (4) to a torque of 22 N·m (16 lb ft).
  7. If the engine oil pressure sensor is located in the engine oil filter base, Install the engine oil pressure sensor. Refer to Disassembly and Assembly, "Engine Oil Pressure Sensor - Remove and Install".
  8. Install a new engine oil filter (3). If necessary, fill the engine oil pan to the correct level that is indicated on the oil level gauge. Refer to Operation and Maintenance Manual, "Engine Oil Level - Check".
-

Product: ENGINE - MACHINE  
Model: C4.4 ENGINE - MACHINE W23  
Configuration: C4.4 Industrial Engine W2300001-UP

## **Disassembly and Assembly**

### **C4.4 Industrial Engine**

Media Number -UENR4457-00

Publication Date -01/09/2014

Date Updated -09/09/2014

i05812346

## **Engine Oil Cooler - Remove**

SMCS - 1378-011

### **Removal Procedure**

---

#### **NOTICE**

**Keep all parts clean from contaminants.**

**Contaminants may cause rapid wear and shortened component life.**

---

---

#### **NOTICE**

**Care must be taken to ensure that fluids are contained during performance of inspection, maintenance, testing, adjusting and repair of the product. Be prepared to collect the fluid with suitable containers before opening any compartment or disassembling any component containing fluids.**

**Dispose of all fluids according to local regulations and mandates.**

---

1. Drain the coolant from the cooling system into a suitable container. Refer to Operation and Maintenance Manual, "Cooling System Coolant - Change" for the correct procedure.
2. Drain the engine lubricating oil into a suitable container. Refer to Operation and Maintenance Manual, "Engine Oil and Filter - Change" for the correct procedure.

3. If necessary, remove the electric starting motor. Refer to Disassembly and Assembly, "Electric Starting Motor - Remove and Install" for the correct procedure.
  4. If necessary, remove the electronic control module mounting bracket. Refer to Disassembly and Assembly, "ECM Mounting Bracket - Remove and Install" for the correct procedure.
- 

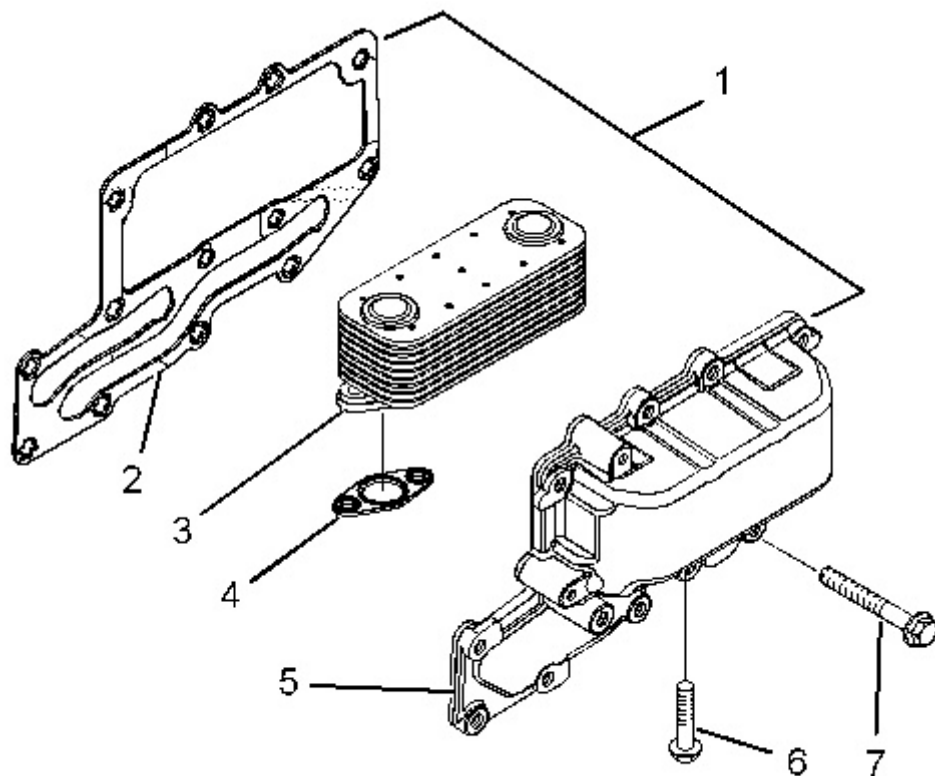

---

Illustration 1  
Typical example

g01343557

---

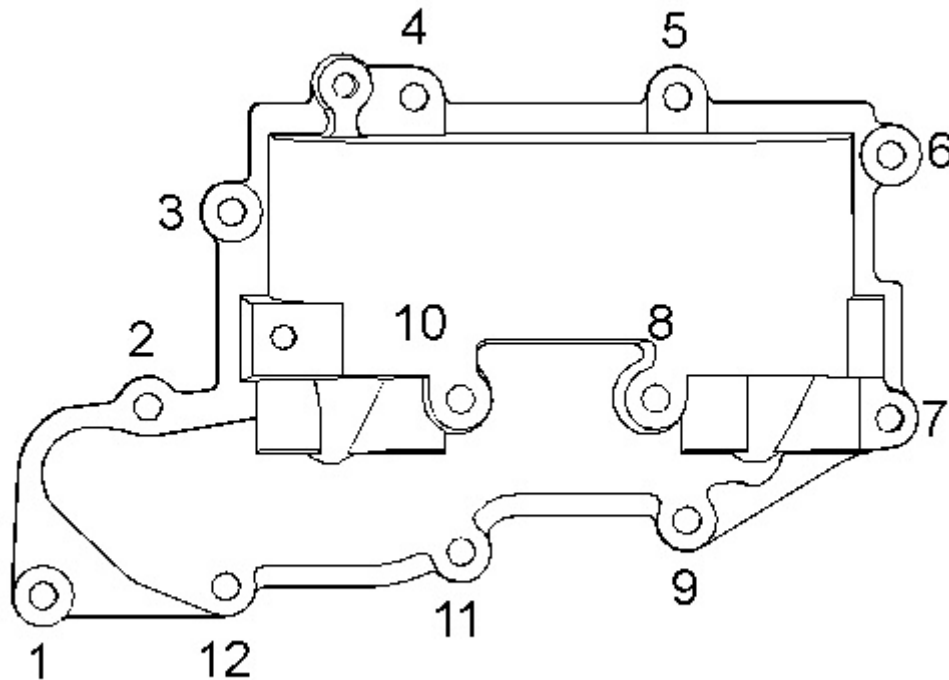

---

Illustration 2

g01343558

Tightening sequence for the engine oil cooler

5. Loosen fasteners (7) in reverse numerical order to the sequence that is shown in Illustration 2. Remove fasteners (7). Support the assembly of the engine oil cooler (1) as the fasteners are removed.

**Note:** fasteners (7) are different lengths. Note the correct position of the fasteners. Note the position of any brackets that are secured by the fasteners. Do not remove fasteners (6) at this time.

6. Remove the assembly of oil cooler (1) from the cylinder block.
  7. Remove joint (2).
  8. Follow Steps 8.a through 8.c in order to disassemble the engine oil cooler.
    - a. Remove bolts (6).
    - b. Remove cooler matrix (3) from housing (5).
    - c. Remove joints (4).
-

Thank you so much for reading.  
Please click the “Buy Now!”  
button below to download the  
complete manual.



After you pay.

You can download the most  
perfect and complete manual in  
the world immediately.

Our support email:

[ebooklibonline@outlook.com](mailto:ebooklibonline@outlook.com)