

Product: INDUSTRIAL ENGINE
Model: C7 INDUSTRIAL ENGINE TEF
Configuration: C7 Industrial Engine TEF00001-UP

Disassembly and Assembly C7 Industrial Engines

Media Number -REN9578-02

Publication Date -01/02/2014

Date Updated -26/02/2014

i02516302

Rocker Arm and Shaft - Remove

SMCS - 1102-011

Removal Procedure

Start By:

- a. Remove the valve mechanism cover. Refer to Disassembly and Assembly, "Valve Mechanism Cover - Remove and Install".

NOTICE

Keep all parts clean from contaminants.

Contaminants may cause rapid wear and shortened component life.

1. Place identification marks on each of the rocker arms in order to identify the proper location for installation.
-

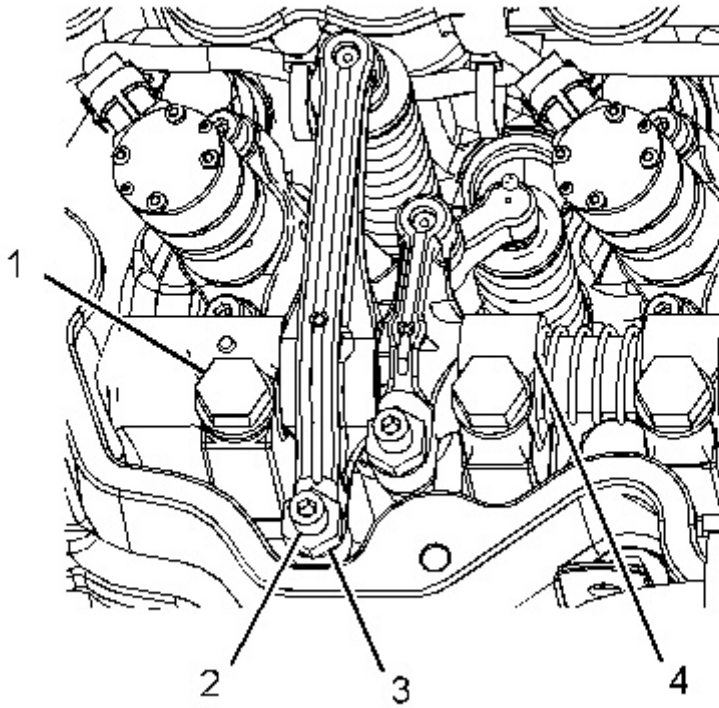

Illustration 1

g01259077

2. Loosen nuts (3) and rocker arm adjustment screws (2).
 3. Remove bolts (1) and rocker shaft (4).
-

Product: INDUSTRIAL ENGINE
Model: C7 INDUSTRIAL ENGINE TEF
Configuration: C7 Industrial Engine TEF00001-UP

Disassembly and Assembly C7 Industrial Engines

Media Number -REN9578-02

Publication Date -01/02/2014

Date Updated -26/02/2014

i02516765

Rocker Arm - Disassemble

SMCS - 1123-015

Disassembly Procedure

Start By:

- a. Remove the rocker arm and shaft. Refer to Disassembly and Assembly, "Rocker Arm and Shaft - Remove".

NOTICE

Keep all parts clean from contaminants.

Contaminants may cause rapid wear and shortened component life.

Note: Place an identification mark on each of the components of the rocker shaft for installation purposes.

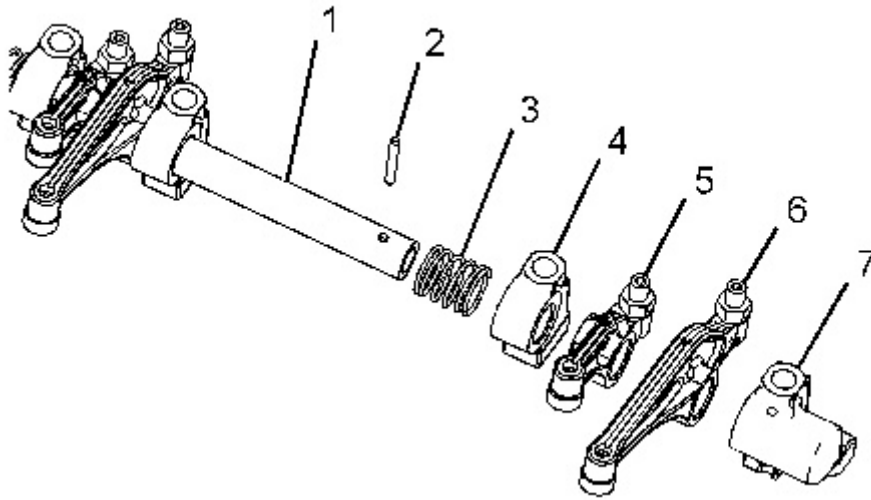

Illustration 1

g01259141

 **WARNING**

Personal injury can result from being struck by parts propelled by a released spring force.

Make sure to wear all necessary protective equipment.

Follow the recommended procedure and use all recommended tooling to release the spring force.

1. Remove dowel (2) from rocker shaft (1).
 2. Remove end stand (7), exhaust rocker arm (6), intake rocker arm (5), stand (4), and spring (3) from rocker shaft (1).
-

Product: INDUSTRIAL ENGINE
Model: C7 INDUSTRIAL ENGINE TEF
Configuration: C7 Industrial Engine TEF00001-UP

Disassembly and Assembly C7 Industrial Engines

Media Number -REN9578-02

Publication Date -01/02/2014

Date Updated -26/02/2014

i02517008

Rocker Arm - Assemble

SMCS - 1123-016

Assembly Procedure

NOTICE

Keep all parts clean from contaminants.

Contaminants may cause rapid wear and shortened component life.

1. Lubricate all components of the rocker arm shaft with clean engine oil.
-

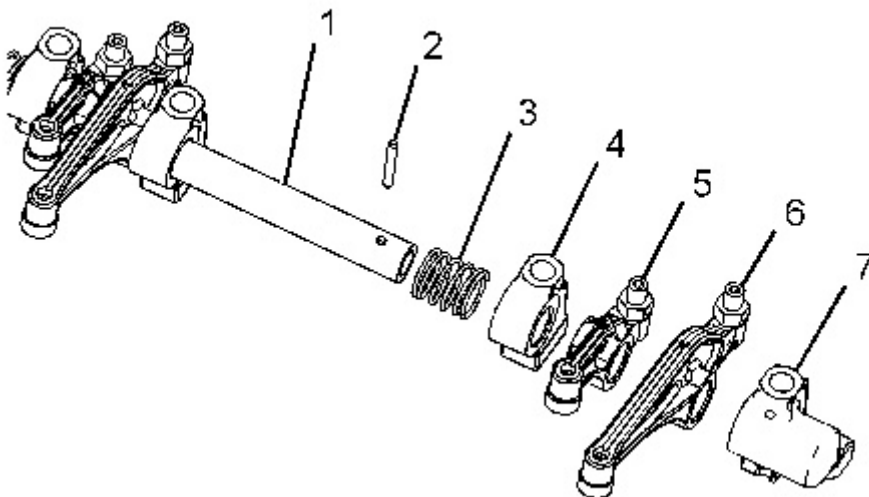



Improper assembly of parts that are spring loaded can cause bodily injury.

To prevent possible injury, follow the established assembly procedure and wear protective equipment.

2. Install spring (3), stand (4), intake rocker arm (5), exhaust rocker arm (6), and end stand (7) on rocker shaft (1).
3. Install dowel (2) into rocker shaft (1).

End By:

- a. Install the rocker arm and shaft. Refer to Disassembly and Assembly, "Rocker Arm and Shaft - Install".
-

Product: INDUSTRIAL ENGINE
Model: C7 INDUSTRIAL ENGINE TEF
Configuration: C7 Industrial Engine TEF00001-UP

Disassembly and Assembly C7 Industrial Engines

Media Number -REN9578-02

Publication Date -01/02/2014

Date Updated -26/02/2014

i07074589

Rocker Arm and Shaft - Install

SMCS - 1102-012

Installation Procedure

Table 1

Required Tools			
Tool	Part Number	Part Description	Qty
A	8T-2998	Lubricant	1

NOTICE

Keep all parts clean from contaminants.

Contaminants may cause rapid wear and shortened component life.

1. Apply Tooling (A) to both ends of the pushrods.
 2. Lubricate the pushrods with clean engine oil. Install the pushrods and the valve bridges.
-

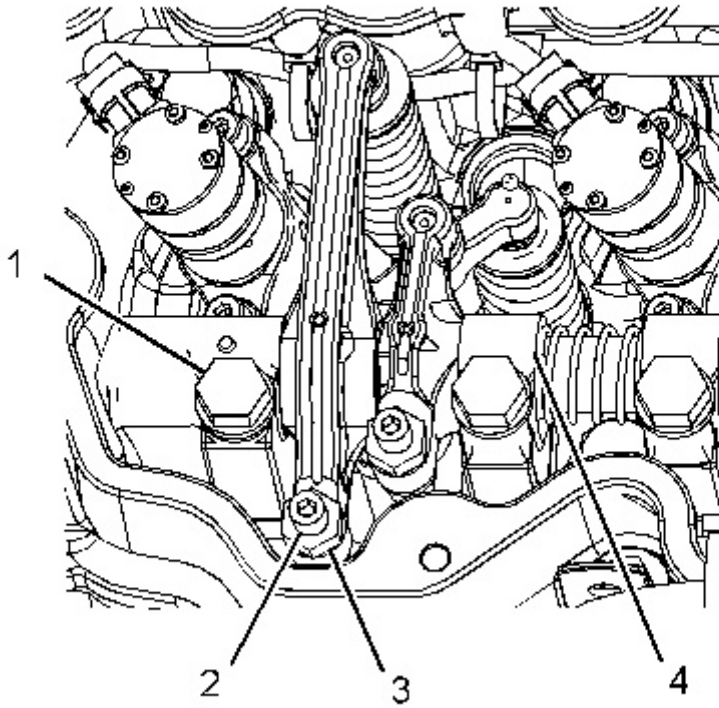

Illustration 1

g01259077

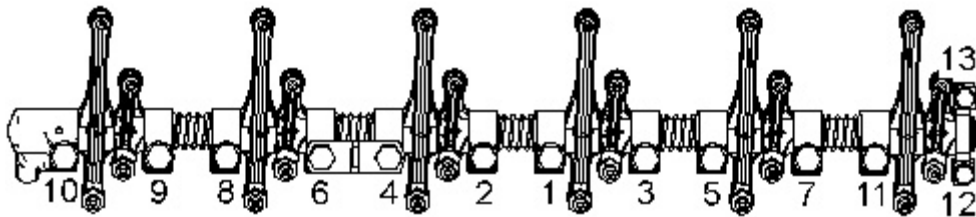

Illustration 2

g01518624

3. Position rocker shaft (4) on the cylinder head. Install bolts (1) and tighten the bolts in a numerical sequence to standard torque.
4. Apply Tooling (A) to each of the bottom faces of the rocker arms.
5. Position rocker arm adjustment screws (2) and tighten nuts (3). Adjust the valve lash of the rocker arms. Refer to Testing and Adjusting, "Engine Valve Lash - Inspect/Adjust".

End By:

- a. Install the valve mechanism cover. Refer to Disassembly and Assembly, "Valve Mechanism Cover - Remove and Install".
-

Product: INDUSTRIAL ENGINE
Model: C7 INDUSTRIAL ENGINE TEF
Configuration: C7 Industrial Engine TEF00001-UP

Disassembly and Assembly C7 Industrial Engines

Media Number -REN9578-02

Publication Date -01/02/2014

Date Updated -26/02/2014

i02517152

Cylinder Head - Remove

SMCS - 1100-011

Removal Procedure

Start By:

- a. Remove the rocker arm and shaft. Refer to Disassembly and Assembly, "Rocker Arm and Shaft - Remove".
- b. Remove the electronic unit injector. Refer to Disassembly and Assembly, "Electronic Unit Injector - Remove".
- c. Remove the valve mechanism cover base. Refer to Disassembly and Assembly, "Valve Mechanism Cover Base - Remove and Install".
- d. Remove the fan drive. Refer to Disassembly and Assembly, "Fan Drive - Remove".

NOTICE

Care must be taken to ensure that fluids are contained during performance of inspection, maintenance, testing, adjusting, and repair of the product. Be prepared to collect the fluid with suitable containers before opening any compartment or disassembling any component containing fluids.

Refer to Special Publication, NENG2500, "Dealer Service Tool Catalog" for tools and supplies suitable to collect and contain fluids on Cat products.

Dispose of all fluids according to local regulations and mandates.

1. Drain the coolant from the cooling system into a suitable container for storage or for disposal. Refer to Operation and Maintenance Manual, "Cooling System Coolant (ELC) - Change".
-

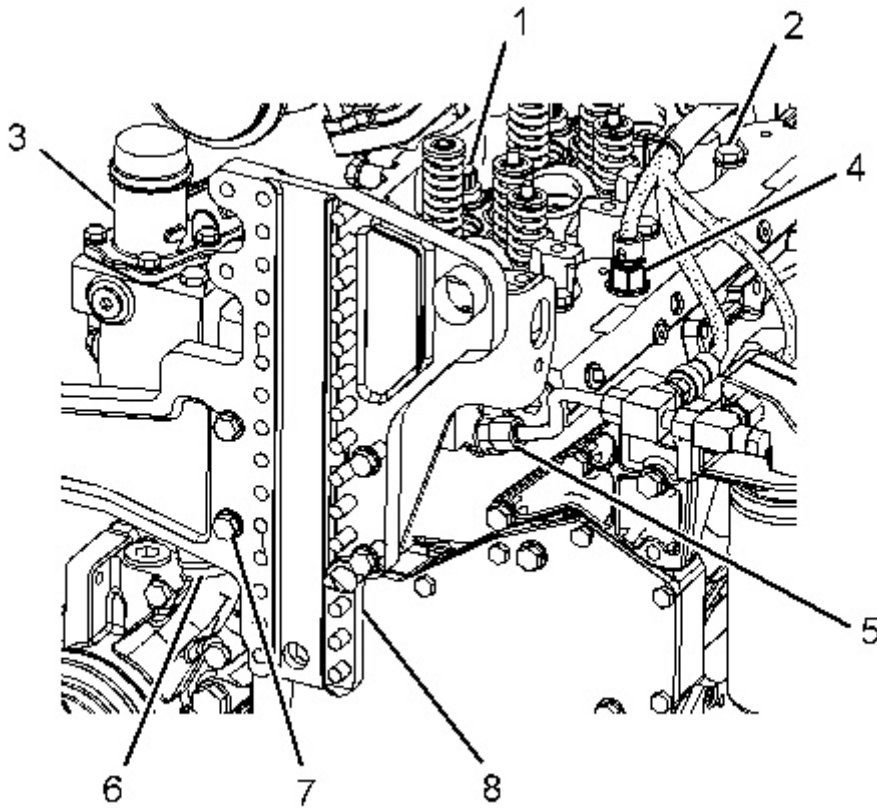

Illustration 1

g01259334

2. Remove bolts (7) and remove support assembly (8). Loosen hose assembly (6) to water regulator (3).
 3. Disconnect harness assembly (4).
 4. Disconnect tube assembly (5).
 5. Remove bolts (1) and (2) and the washers.
-

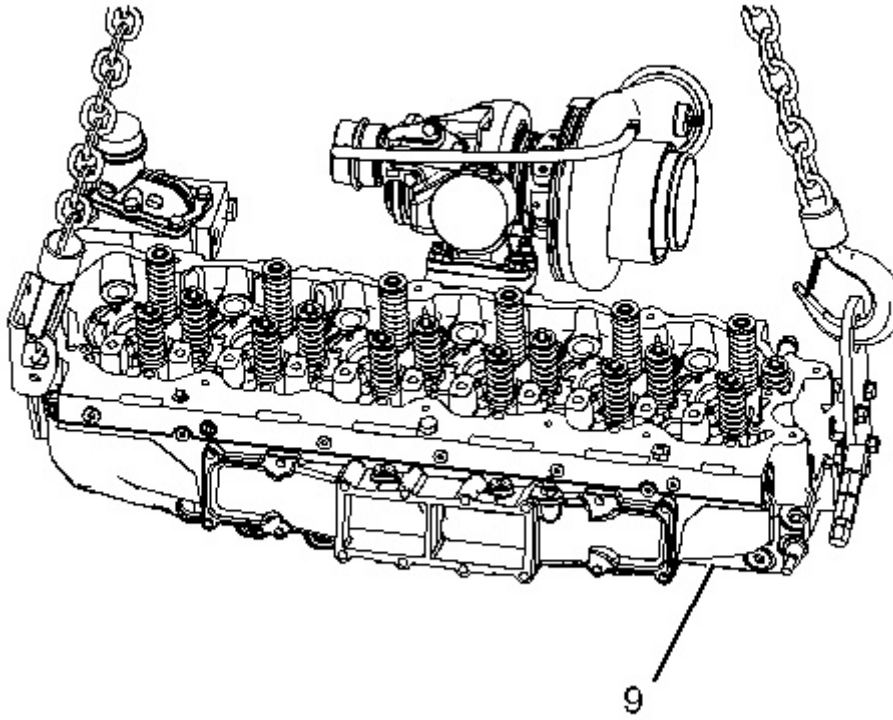

Illustration 2

g01259335

6. Attach a suitable lifting device onto cylinder head (9). The weight of cylinder head (9) is approximately 108 kg (238 lb). Remove cylinder head (9) and the gasket.
-

Product: INDUSTRIAL ENGINE
Model: C7 INDUSTRIAL ENGINE TEF
Configuration: C7 Industrial Engine TEF00001-UP

Disassembly and Assembly C7 Industrial Engines

Media Number -REN9578-02

Publication Date -01/02/2014

Date Updated -26/02/2014

i02995476

Cylinder Head - Install

SMCS - 1100-012

Installation Procedure

Table 1

Required Tools			
Tool	Part Number	Part Description	Qty
A	6V-4876	Lubricant	-

NOTICE

Keep all parts clean from contaminants.

Contaminants may cause rapid wear and shortened component life.

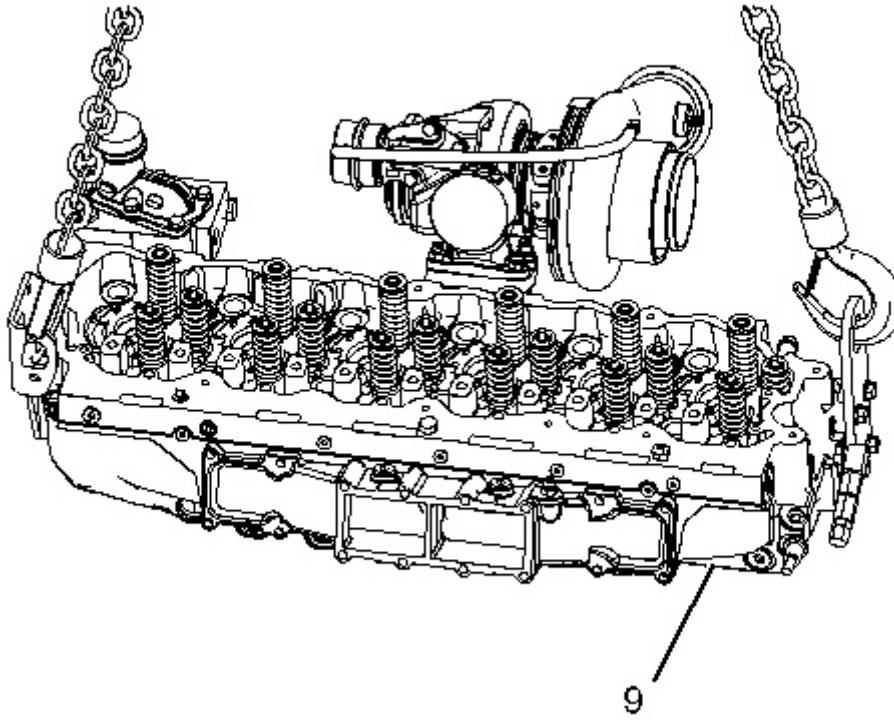

Illustration 1

g01259335

1. Install the new cylinder head gasket.
 2. Attach a suitable lifting device to cylinder head (9). The weight of cylinder head (9) is approximately 108 kg (238 lb). Position cylinder head (9) onto the dowels in the cylinder block.
-

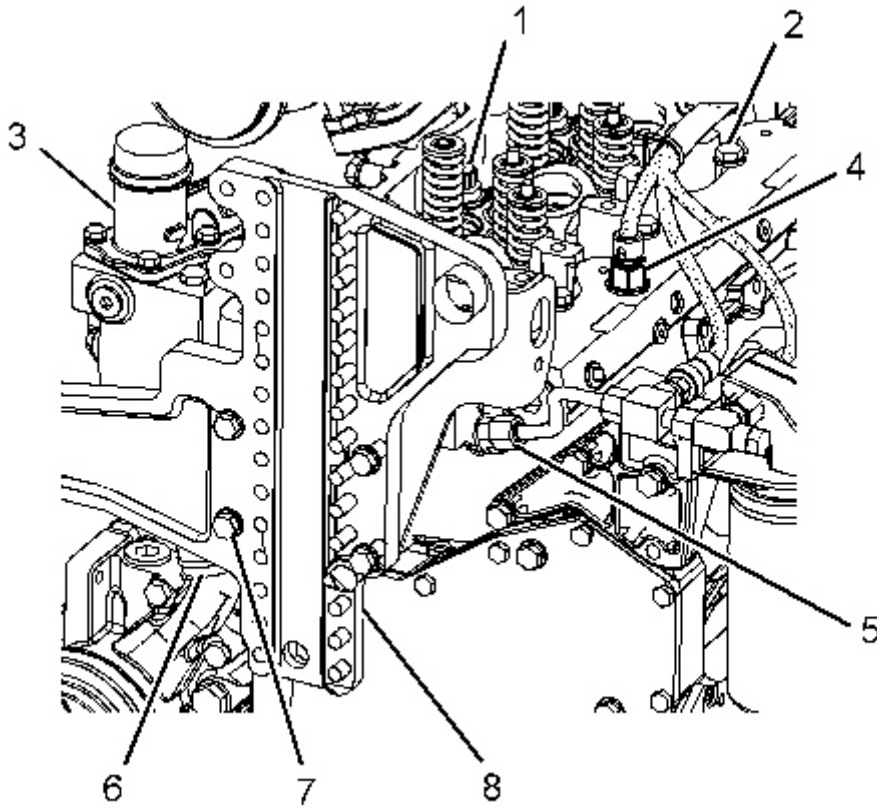

Illustration 2

g01259334

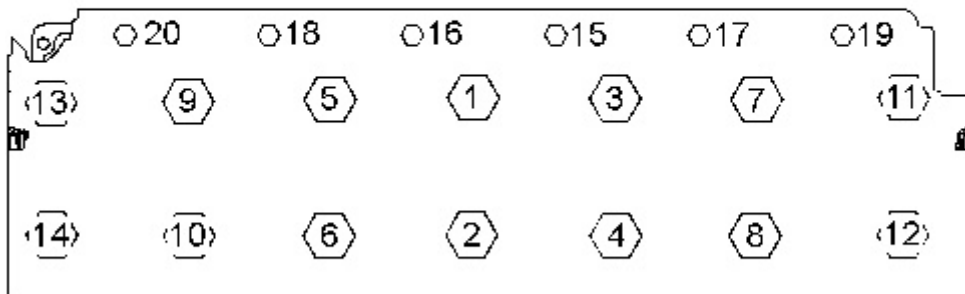

Illustration 3

g01183163

3. Use Tooling (A) to lubricate bolts (1), bolts (2), and the washers. Install bolts (1) and bolts (2).
4. Tighten the cylinder head bolts according to the following procedure:

- a. Tighten Bolt (1) through Bolt (14) in a numerical sequence to a torque of $300 \pm 15 \text{ N}\cdot\text{m}$ ($221 \pm 11 \text{ lb ft}$).
 - b. Loosen Bolt (1) through Bolt (14) until the washers are loose under the bolt heads.
 - c. Tighten Bolt (1) through Bolt (14) in a numerical sequence to a torque of $130 \pm 15 \text{ N}\cdot\text{m}$ ($95 \pm 11 \text{ lb ft}$).
 - d. Tighten Bolt (1) through Bolt (14) again in a numerical sequence to a torque of $130 \pm 15 \text{ N}\cdot\text{m}$ ($95 \pm 11 \text{ lb ft}$).
 - e. Turn Bolt (1) through Bolt (14) in a numerical sequence for an additional 90° ($1/4$ turn).
 - f. Tighten Bolt (15) through Bolt (20) in a numerical sequence to a torque of $55 \pm 7 \text{ N}\cdot\text{m}$ ($41 \pm 5 \text{ lb ft}$).
5. Connect tube assembly (5).
 6. Connect harness assembly (4).
 7. Position water regulator (3) and tighten hose assembly (6).
 8. Position support assembly (8) and install bolts (7).
 9. Fill the coolant system. Refer to Operation and Maintenance Manual, "Refill Capacities and Recommendations".

End By:

- a. Install the fan drive. Refer to Disassembly and Assembly, "Fan Drive - Install".
 - b. Install the valve mechanism cover base. Refer to Disassembly and Assembly, "Valve Mechanism Cover Base - Remove and Install".
 - c. Install the electronic unit injectors. Refer to Disassembly and Assembly, "Electronic Unit Injector - Install".
 - d. Install the rocker arm and shaft. Refer to Disassembly and Assembly, "Rocker Arm and Shaft - Install".
-

Product: INDUSTRIAL ENGINE
Model: C7 INDUSTRIAL ENGINE TEF
Configuration: C7 Industrial Engine TEF00001-UP

Disassembly and Assembly C7 Industrial Engines

Media Number -REN9578-02

Publication Date -01/02/2014

Date Updated -26/02/2014

i02996121

Lifter Group - Remove and Install

SMCS - 1209-010

Removal Procedure

Start By:

- a. Remove the aftercooler, if necessary. Refer to Disassembly and Assembly, "Aftercooler - Remove".
- b. Remove the auxiliary water pump, if necessary. Refer to Disassembly and Assembly, "Auxiliary Water Pump - Remove".
- c. Remove the unit injector hydraulic pump. Refer to Disassembly and Assembly, "Unit Injector Hydraulic Pump - Remove".
- d. Remove the rocker arms and the shaft. Refer to Disassembly and Assembly, "Rocker Arm and Shaft - Remove".
- e. Remove the electronic control module (ECM). Refer to Disassembly and Assembly, "Electronic Control Module - Remove and Install".

NOTICE

Keep all parts clean from contaminants.

Contaminants may cause rapid wear and shortened component life.

NOTICE

Care must be taken to ensure that fluids are contained during performance of inspection, maintenance, testing, adjusting, and repair of the product. Be prepared to collect the fluid with suitable containers before opening any compartment or disassembling any component containing fluids.

Refer to Special Publication, NENG2500, "Dealer Service Tool Catalog" for tools and supplies suitable to collect and contain fluids on Cat products.

Dispose of all fluids according to local regulations and mandates.

1. Remove the pushrods from the engine.
-

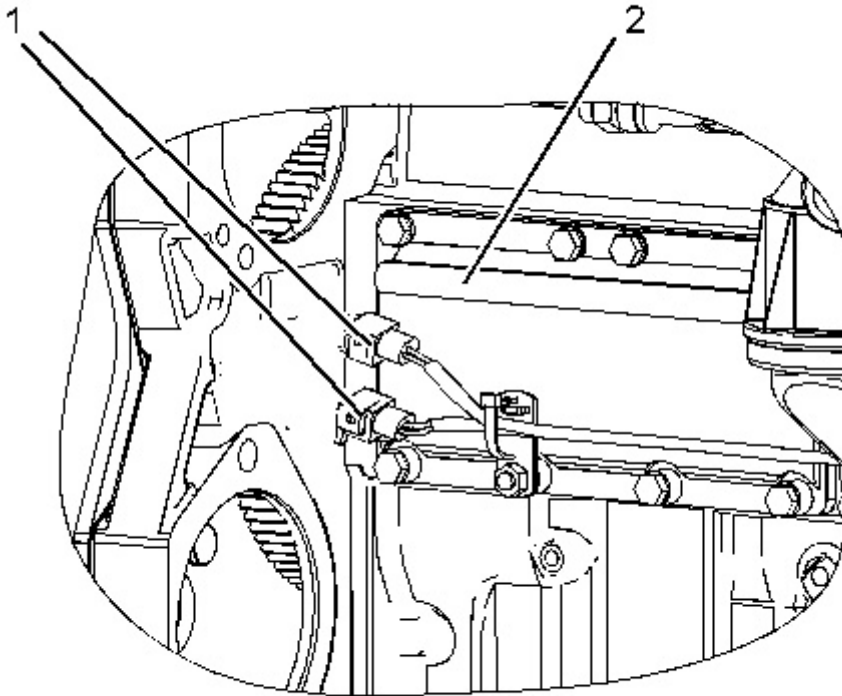

Illustration 1

g01027496

2. Position engine speed/timing sensors (1) out of the way.
 3. Remove the bolts and side covers (2).
-

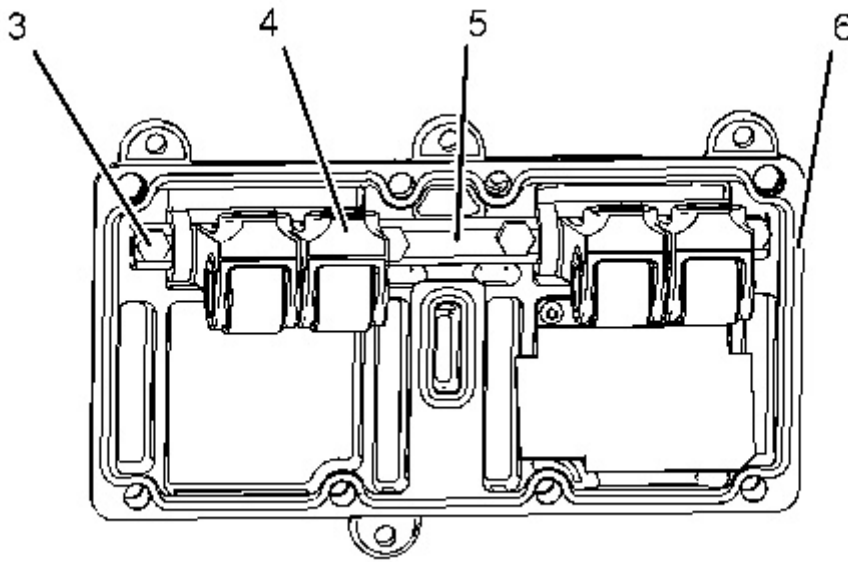

Illustration 2

g01027497

4. Remove bolts (3) and the dowels that hold lifter arms (4) and lifter shaft (5) to each side cover. Remove gasket (6).

Installation Procedure

Table 1

Required Tools			
Tool	Part Number	Part Description	Qty
A	9S-3263	Thread Lock Compound	1
B	1U-8846	Gasket Sealant	1

NOTICE

Keep all parts clean from contaminants.

Contaminants may cause rapid wear and shortened component life.

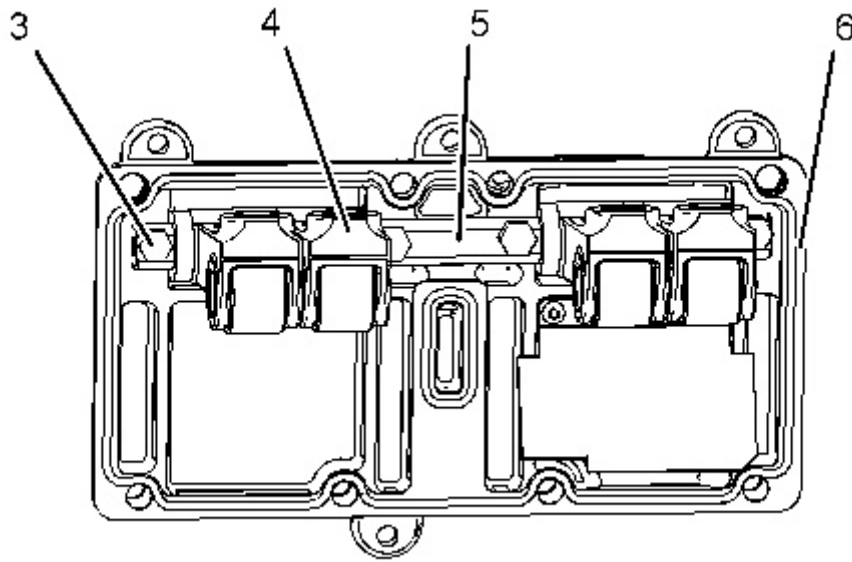

Illustration 3

g01027497

1. Install gasket (6).
 2. Install lifter arms (4) on lifter shaft (5).
 3. Position lifter shaft (5) and the dowels on the side cover. Ensure that the oil holes in the lifter shaft are facing the side cover. Apply Tooling (A) to the threads of bolts (3). Install bolts (3). Tighten bolts (3) to a torque of 13 ± 3 N·m (115 ± 27 lb in). Tighten the center bolts. Then tighten the bolts on the end.
 4. Lubricate the lifters with clean engine oil.
 5. Apply Tooling (B) to the sealing surfaces of the side cover. The side covers must be installed on the cylinder block within 10 minutes of applying the sealant.
-

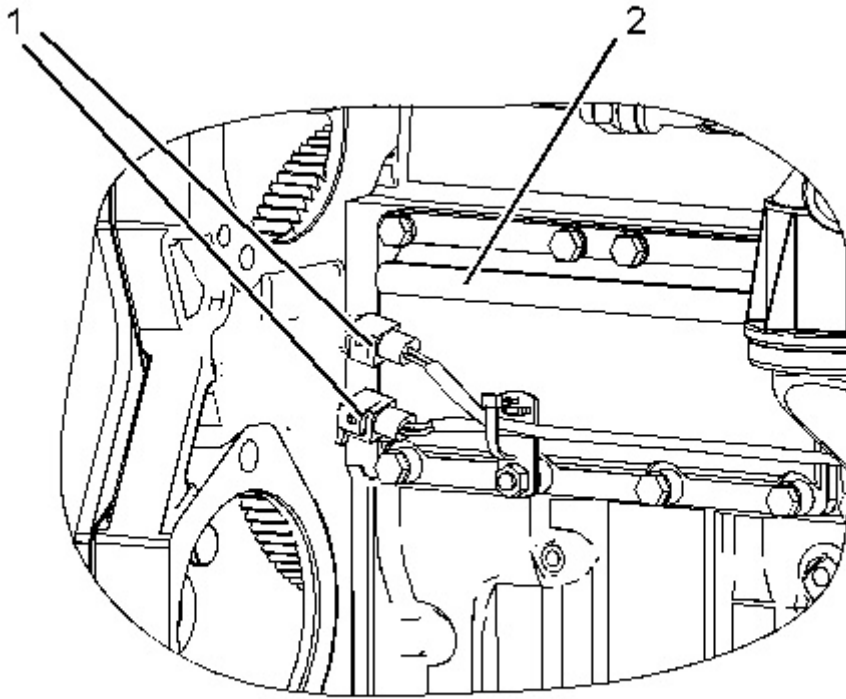

Illustration 4

g01027496

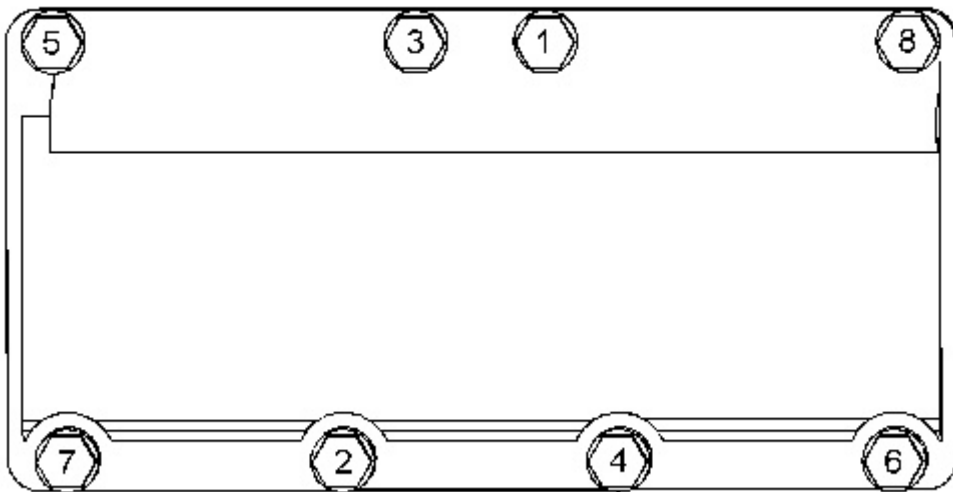

Illustration 5

g01519208

6. Position the gaskets and side covers (2) on the cylinder block. Install the bolts. Tighten the bolts in a numerical sequence. Tighten the bolts again in a numerical sequence.
7. Install engine speed/timing sensors (1).

8. Install the pushrods in the engine.

End By:

- a. Install the electronic control module (ECM). Refer to Disassembly and Assembly, "Electronic Control Module - Remove and Install".
 - b. Install the rocker arms and the shaft. Refer to Disassembly and Assembly, "Rocker Arm and Shaft - Install".
 - c. Install the unit injector hydraulic pump. Refer to Disassembly and Assembly, "Unit Injector Hydraulic Pump - Install".
 - d. Install the auxiliary water pump, if necessary. Refer to Disassembly and Assembly, "Auxiliary Water Pump - Install".
 - e. Install the aftercooler, if necessary. Refer to Disassembly and Assembly, "Aftercooler - Install".
-

Product: INDUSTRIAL ENGINE
Model: C7 INDUSTRIAL ENGINE TEF
Configuration: C7 Industrial Engine TEF00001-UP

Disassembly and Assembly C7 Industrial Engines

Media Number -REN9578-02

Publication Date -01/02/2014

Date Updated -26/02/2014

i02996387

Camshaft - Remove

SMCS - 1210-011

Removal Procedure

Table 1

Required Tools			
Tool	Part Number	Part Description	Qty
A	1U-7638	Magnetic Holding Tool	12

Start By:

- Remove the rocker arms and the shaft. Refer to Disassembly and Assembly, "Rocker Arm and Shaft - Remove".
- Remove the front cover. Refer to Disassembly and Assembly, "Front Cover - Remove and Install".

NOTICE

Keep all parts clean from contaminants.

Contaminants may cause rapid wear and shortened component life.

NOTICE

Care must be taken to ensure that fluids are contained during performance of inspection, maintenance, testing, adjusting, and repair

of the product. Be prepared to collect the fluid with suitable containers before opening any compartment or disassembling any component containing fluids.

Refer to Special Publication, NENG2500, "Dealer Service Tool Catalog" for tools and supplies suitable to collect and contain fluids on Cat products.

Dispose of all fluids according to local regulations and mandates.

1. Remove the pushrods from the engine.
 2. Turn the crankshaft to top center compression stroke for the No. 1 piston. Refer to Testing and Adjusting, "Finding Top Center Position for No. 1 Piston".
-

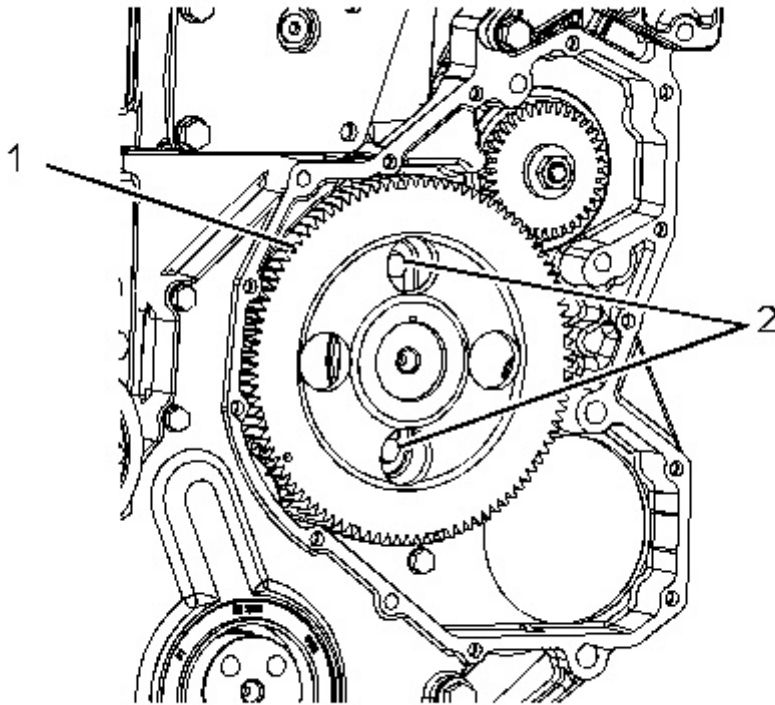

Illustration 1

g01259668

Thank you so much for reading.
Please click the “Buy Now!”
button below to download the
complete manual.



After you pay.

You can download the most
perfect and complete manual in
the world immediately.

Our support email:

ebooklibonline@outlook.com